



87C196CB 20 MHz Advanced 16-Bit CHMOS Microcontroller with Integrated CAN 2.0

Automotive

Production Datasheet

Product Features

- -40°C to +125°C Ambient
- High Performance CHMOS 16-Bit CPU
- Up to 56 Kbytes of On-Chip EPROM
- Up to 1.5 Kbyte of On-Chip Register RAM
- Up to 512 Bytes of Additional RAM (Code RAM)
- Register-Register Architecture
- 8 Channel/10-Bit A/D with Sample/Hold
- 38 Prioritized Interrupts
- Up to Seven 8-Bit (56) I/O Ports
- Full Duplex Serial I/O Port with Dedicated Baud Rate Generator
- Interprocessor Communication Slave Port
- Oscillator Fail Detection Circuitry
- 15 Message Objects of 8 Bytes Data Length
- Up to 16 Mbyte Linear Address Space
- High Speed Peripheral Transaction Server (PTS)
- Two Dedicated 16-Bit High-Speed Compare Registers
- 10 High Speed Capture/Compare (EPA)
- Full Duplex Synchronous Serial I/O Port (SSIO)
- Two Flexible 16-Bit Timer Counters
- Flexible 8-/16-Bit External Bus (Programmable)
- Programmable Bus (HLD/HLDA)
- 1.4 μ s 16 x 16 Multiply
- 2.4 μ s 32/16 Divide
- 20 MHz Operation¹
- Supports CAN (Controller Area Network) Specification 2.0

¹. 16 MHz standard; 20 MHz is speed premium.

Notice: This document contains information on products in full production. The specifications are subject to change without notice. Verify with your local Intel sales office that you have the latest datasheet before finalizing a design.

Information in this document is provided in connection with Intel products. No license, express or implied, by estoppel or otherwise, to any intellectual property rights is granted by this document. Except as provided in Intel's Terms and Conditions of Sale for such products, Intel assumes no liability whatsoever, and Intel disclaims any express or implied warranty, relating to sale and/or use of Intel products including liability or warranties relating to fitness for a particular purpose, merchantability, or infringement of any patent, copyright or other intellectual property right. Intel products are not intended for use in medical, life saving, or life sustaining applications.

Intel may make changes to specifications and product descriptions at any time, without notice.

Designers must not rely on the absence or characteristics of any features or instructions marked "reserved" or "undefined." Intel reserves these for future definition and shall have no responsibility whatsoever for conflicts or incompatibilities arising from future changes to them.

The 87C196CB - *Automotive* may contain design defects or errors known as errata which may cause the product to deviate from published specifications. Current characterized errata are available on request.

Contact your local Intel sales office or your distributor to obtain the latest specifications and before placing your product order.

Copies of documents which have an ordering number and are referenced in this document, or other Intel literature, may be obtained from:

Intel Corporation
PO Box 5937
Denver CO 80217-9808
call 1-800-548-4725

Copyright © Intel Corporation 1997, 2004

*Third-party brands and names are the property of their respective owners.

Contents

1.0	Introduction	1
2.0	Block Diagram.....	2
3.0	Process Information	3
4.0	Pin Descriptions	6
5.0	Electrical Characteristics.....	10
5.1	DC Characteristics	10
5.1.1	87C196CB - Automotive Additional Bus Timing Modes	12
5.1.1.1	MODE 3.....	12
5.1.1.2	MODE 0.....	12
5.2	AC Characteristics.....	12
5.2.1	Test Conditions	12
5.2.2	87C196CB - Automotive Timings	15
5.2.3	87C196CB Timings	16
5.2.4	87C196CB - Automotive Timings	17
5.2.5	87C196CB - Automotive AC Characteristics - Slave Port	18
5.2.6	Explanation of AC Symbols.....	22
5.3	EPROM Specifications	23
5.3.1	AC EPROM Programming Characteristics	23
5.3.2	EPROM Programming Waveforms	24
5.4	AC Characteristics - Serial Port - Shift Register Mode.....	26
5.4.1	A/D Characteristics.....	27
5.4.1.1	A/D Converter Specification	27
6.0	Datasheet Revision History.....	30

Figures

1	87C196CB - Automotive Block Diagram	2
2	The 87C196CB - Automotive Family Nomenclature	3
3	84-Pin PLCC x87C196CB Diagram	4
4	100-Pin QFP x87C196CB Diagram	5
5	Chip Configuration Registers	9
6	87C196CB I _{CC} vs Frequency	11
7	87C196CB - Automotive System Bus Timing	15
8	87C196CB - Automotive Ready Timings (One Wait State).....	16
9	87C196CB Buswidth Timings	16
10	87C196CB HOLD#/HOLDA# Timings.....	17
11	Slave Port Waveform - (SLPL = 0).....	18
12	Slave Port Waveform - (SLPL = 1).....	19
13	Synchronous Serial Port	20
14	External Clock Drive Waveforms	21
15	Input/Output Test Conditions	21
16	Float Test Conditions	22
17	Slave Programming Mode Data Program Mode with Single Program Pulse ..	24
18	Slave Programming Mode in Word Dump or Data Verify Mode with Auto Increment	24
19	Slave Programming Mode Timing in Data Program Mode with Repeated Program Pulse and Auto Increment	25
20	Waveform - Serial Port - Shift Register Mode	26
21	AD_TIME 1FAFH:Byte	27

Tables

1	Device Overview	1
1	Thermal Characteristics	3
2	Pin Descriptions	6
3	87C196CB Memory Map.....	8
4	DC Characteristics (Under Listed Operating Conditions).....	10
5	AC Characteristics (Over Specified Operating Conditions).....	12
6	AC Characteristics (Over Specified Operating Conditions).....	14
7	8x196CB HOLD#/HOLDA# Timings (Over Specified Operation Conditions).....	17
8	Slave Port Timing - (SLPL = 0, 1, 2, 3)	18
9	Slave Port Timing - (SLPL = 1, 2, 3)	19
10	Normal Master/Slave Operation	20
11	Handshake Operation	20
12	External Clock Drive.....	21
13	Explanation of AC Symbols.....	22
14	AC EPROM Programming Characteristics.....	23
15	DC EPROM Programming Characteristics	23
16	Serial Port Timing - Shift Register Mode	26
17	10-Bit Mode A/D Operating Conditions	27
18	10-Bit Mode A/D Characteristics (Using Above Operating Conditions) (1)	28
19	8-Bit Mode A/D Operating Conditions	28
20	8-Bit Mode A/D Characteristics (Using Above Operating Conditions) (1)	29

1.0 Introduction

The 87C196CB - *Automotive* is a member of the MCS[®] 96 microcontroller family. This device is based upon the MCS 96 Kx/Jx microcontroller product families with enhancements ideal for automotive and industrial applications. The 87C196CB - *Automotive* is the first device in the Kx family to support networking through the integration of the CAN 2.0 (Controller Area Network) peripheral on-chip. The 87C196CB offers the highest memory density of the MCS 96 microcontroller family, with 56K of on-chip EPROM, 1.5K of on-chip register RAM, and 512 bytes of additional RAM (Code RAM). In addition, the 87C196CB provides up to 16 Mbyte of Linear Address Space.

Table 1. Device Overview

Device	Pins/ Package	EPROM	Reg RAM	Code RAM	I/O	EPA	SIO	SSIO	CAN	A/D	Addr Space
87C196CB	84-Pin PLCC	56K	1.5K	512b	56	10	Y	Y	Y	8	1 Mbyte
87C196CB	100-Pin QFP	56K	1.5K	512b	60	10	Y	Y	Y	8	16 Mbyte

2.0 Block Diagram

The MCS 96 microcontroller family members are all high-performance microcontrollers with a 16-bit CPU. The 87C196CB is composed of the high-speed (20 MHz) macrocore with up to 16 Mbyte linear address space, 56 Kbytes of program EPROM, up to 1.5 Kbytes of register RAM, and up to 512 bytes of code RAM (16-bit addressing modes) with the ability to execute from this RAM space. It supports the high-speed, serial communications protocol CAN 2.0, with 15 message objects of 8 bytes data length, an 8-channel, 10-bit / 3 LSB analog to digital converter with programmable S/H times, and conversion times < 15 μ s at 20 MHz. It has an asynchronous/synchronous serial I/O port (SIO) with a dedicated 16-bit baud rate generator, an additional synchronous serial I/O port (SSIO) with full duplex master/slave transceivers, a flexible timer/counter structure with prescaler, cascading, and quadrature capabilities. There are ten modularized, multiplexed, high-speed I/O for capture and compare (called Event Processor Array) with 200 ns resolution and double buffered inputs, and a sophisticated prioritized interrupt structure with programmable Peripheral Transaction Server (PTS) implementing several channel modes, including single/burst block transfers from any memory location to any memory location, a PWM and PWM toggle mode to be used in conjunction with the EPA, and an A/D scan mode.

Figure 1. 87C196CB - Automotive Block Diagram

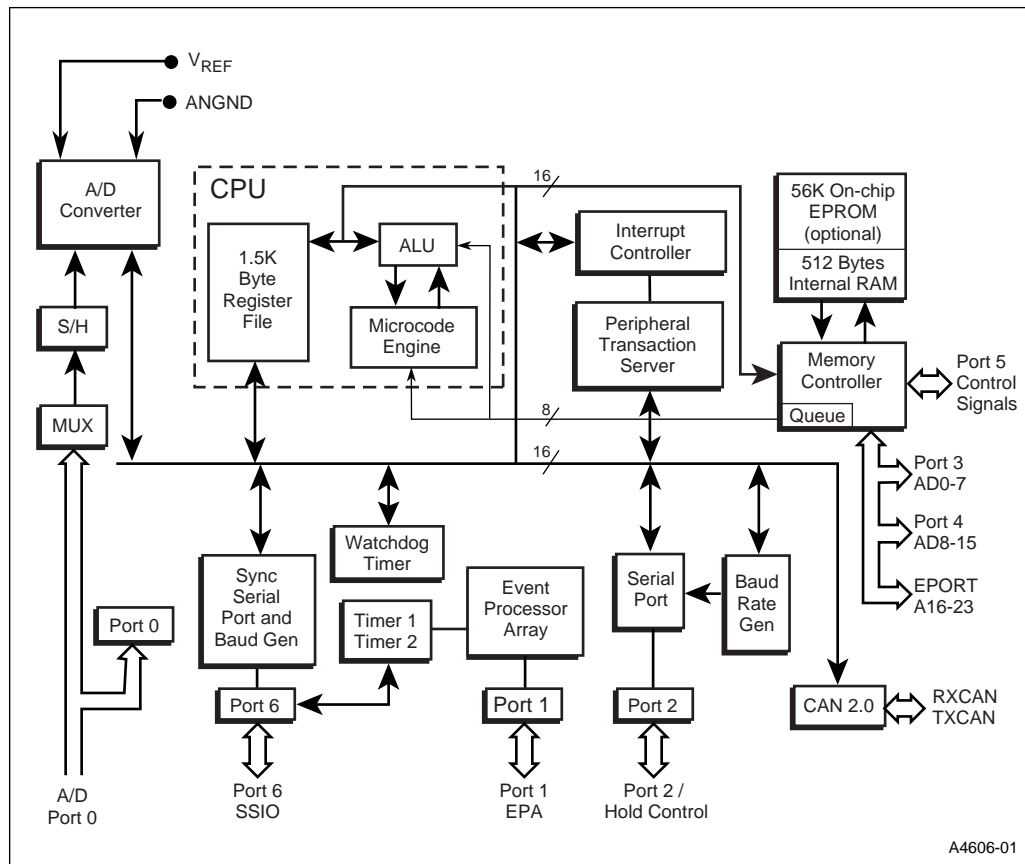

A4606-01

3.0 Process Information

These devices are manufactured on P629.5, a CHMOS III-E process. Additional process and reliability information is available in Intel's *Components Quality and Reliability Handbook*, Order Number 210997.

All thermal impedance data is approximate for static air conditions at 1 W of power dissipation. Values change depending on operation conditions and application. See the Intel *Packaging Handbook* (order number 240800) for a description of Intel's thermal impedance test methodology.

Figure 2. The 87C196CB - Automotive Family Nomenclature

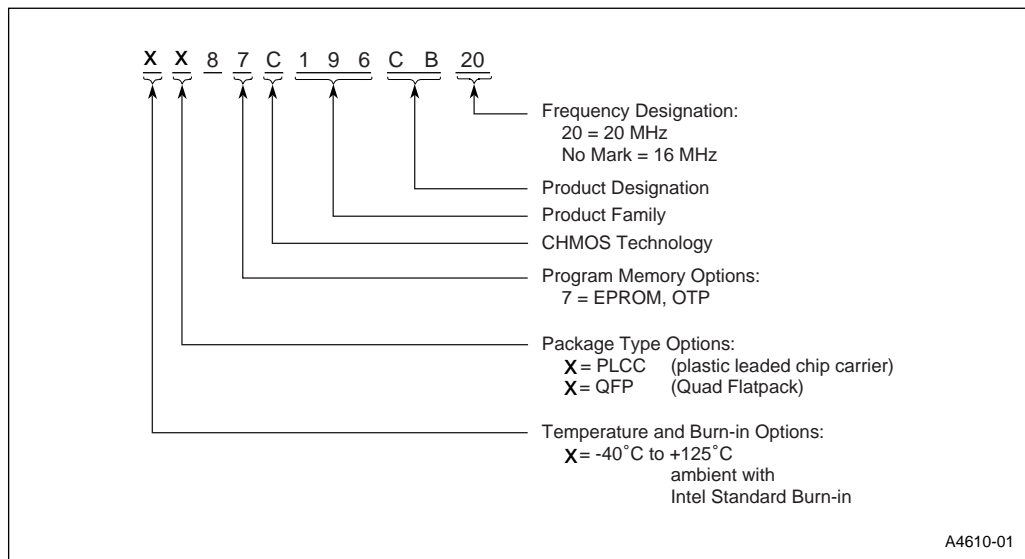

Table 2. Thermal Characteristics

Device and Package	Θ_{JA}	Θ_{JC}
xx87C196CB (84-Lead PLCC Package)	35°C/W	11°C/W

NOTES:

- Θ_{JA} = Thermal resistance between junction and the surrounding environment (ambient) measurements are taken 1 ft. away from case in air flow environment.
 Θ_{JV} = Thermal resistance between junction and package face (case).
- All values of Θ_{JA} and Θ_{JC} may fluctuate depending on the environment (with or without airflow, and how much airflow)
- and device power dissipation at temperature of operation. Typical variations are $\pm 2^\circ\text{C/W}$.
- Values listed are at a maximum power dissipation of 1 W.
- To address the fact that many of the package prefix variables have changed, all package prefix variables in this document are now indicated with an "x".

Figure 3. 84-Pin PLCC xx87C196CB Diagram

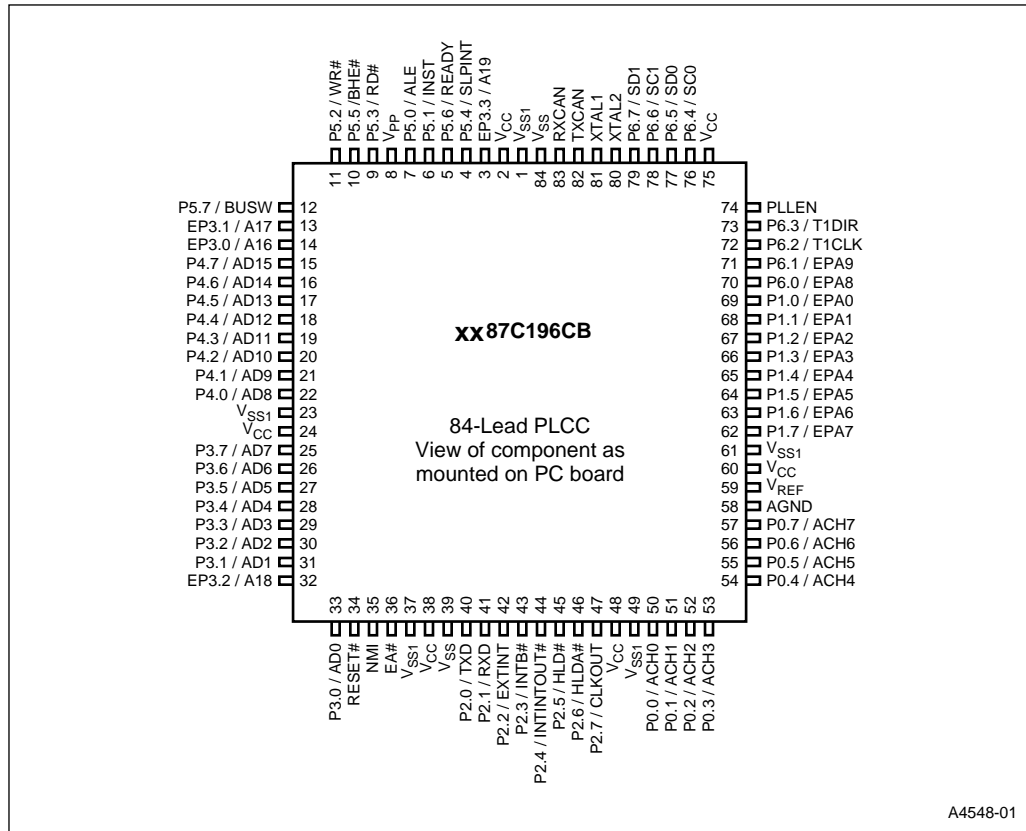
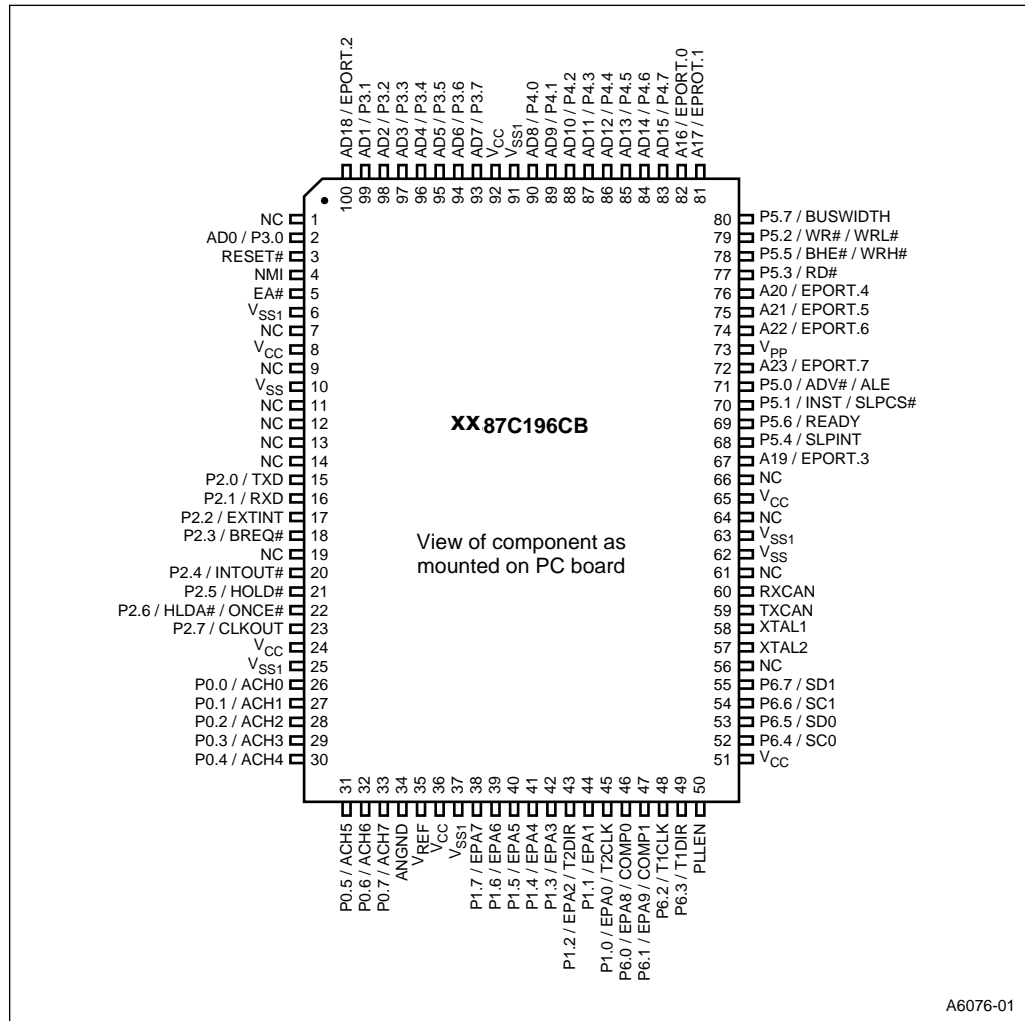

Figure 4. 100-Pin QFP xx87C196CB Diagram



4.0 Pin Descriptions

Table 3. Pin Descriptions (Sheet 1 of 2)

Name	Description
V _{CC}	Main supply voltage (+5 V).
V _{SS} , V _{SS1}	Digital circuit ground (0 V). There are seven V _{SS} pins, all of which MUST be connected to a single ground plane.
V _{REF}	Reference for the A/D converter (+5 V). V _{REF} is also the supply voltage to the analog portion of the A/D converter and the logic used to read Port 0. Must be connected for A/D and Port 0 to function.
V _{PP}	Programming voltage for the EPROM parts. It should be +12.5 V for programming. It is also the timing pin for the return from powerdown circuit. Connect this pin with a 1 μF capacitor to V _{SS} and a 1 MΩ resistor to V _{CC} . If this function is not used, V _{PP} may be tied to V _{CC} .
ANGND	Reference ground for the A/D converter. Must be held at nominally the same potential as V _{SS} .
XTAL1	Input of the oscillator inverter and the internal clock generator.
XTAL2	Output of the oscillator inverter.
RESET#	Reset input to the chip. Input low for at least 16 state times resets the chip. The subsequent low-to-high transition resynchronizes CLKOUT and commences a 10-state time sequence in which the PSW is cleared, bytes are read from 2018H, 201AH and 201CH (if enabled) loading the CCBs, and a jump to location 2080H is executed. Input high for normal operation. RESET# has an internal pullup.
NMI	A positive transition causes a non-maskable interrupt vector through memory location 203EH. If not used, this pin should be tied to V _{SS} . May be used by Intel Evaluation boards.
EA#	Input for memory select (External Access). EA# equal to a high causes memory accesses to locations 0FF2000H through 0FFFFFFH to be directed to on-chip EPROM/ROM. EA# equal to a low causes accesses to these locations to be directed to off-chip memory. EA# = +12.5 V causes execution to begin in the Programming Mode. EA# latched at reset.
PLLEN	Selects between PLL mode or PLL bypass mode. This pin must be either tied high or low. PLLEN pin = 0, bypass PLL mode. PLLEN pin = 1, places a 4x PLL at the input of the crystal oscillator. Allows for a low frequency crystal to drive the device (i.e., 5 MHz = 20 MHz operation).
P6.4-6.7/SSIO	Dual-function I/O ports that have a system function as Synchronous Serial I/O. Two pins are clocks and two pins are data, providing full duplex capability. Also, LSIO when not used as SSIO.
P6.3/T1DIR	Dual-function I/O pin. Primary function is that of a bidirectional I/O pin, however, it may also be used as a TIMER1 Direction input. The TIMER1 increments when this pin is high and decrements when this pin is low.
P6.2/T1CLK	Dual-function I/O pin. Primary function is that of a bidirectional I/O pin, however may also be used as a TIMER1 Clock input. The TIMER1 increments or decrements on both positive and negative edges of this pin.
P6.0-6.1/EPA8-9	Dual-function I/O port pins. Primary function is that of bidirectional I/O. System function is that of High Speed capture and compare.
P5.7/BUSWIDTH	Input for bus width selection. If CCR bit 1 is a one and CCR1 bit 2 is a one, this pin dynamically controls the Buswidth of the bus cycle in progress. If BUSWIDTH is low, an 8-bit cycle occurs, if BUSWIDTH is high, a 16-bit cycle occurs. If CCR bit 1 is "0" and CCR1 bit 2 is "1", all bus cycles are 8-bit, if CCR bit 1 is "1" and CCR1 bit 2 is "0", all bus cycles are 16-bit. CCR bit 1 = "0" and CCR1 bit 2 = "0" is illegal. Also an LSIO pin when not used as BUSWIDTH.
P5.6/READY	Ready input to lengthen external memory cycles, for interfacing with slow or dynamic memory, or for bus sharing. If the pin is high, CPU operation continues in a normal manner. If the pin is low prior to the falling edge of CLKOUT, the memory controller goes into a wait state mode until the next positive transition in CLKOUT occurs with READY high. When external memory is not used, READY has no effect. The max number of wait states inserted into the bus cycle is controlled by the CCR/CCR1. Also an LSIO if READY is not selected.

Table 3. Pin Descriptions (Sheet 2 of 2)

Name	Description
P5.5/BHE#/WRH#	Byte High Enable or Write High output, as selected by the CCR. BHE# = 0 selects the bank of memory that is connected to the high byte of the data bus. A0 = 0 selects the bank of memory that is connected to the low byte. Thus accesses to a 16-bit wide memory can be to the low byte only (A0 = 0, BHE# = 1), to the high byte only (A0 = 1, BHE# = 0) or both bytes (A0 = 0, BHE# = 0). If the WRH# function is selected, the pin goes low if the bus cycle is writing to an odd memory location. BHE#/WRH# is only valid during 16-bit external. Also an LSIO pin when not BHE/WRH#.
P5.4/SLPINT	Dual-function I/O pin. As a bidirectional port pin or as a system function. The system function is a Slave Port Interrupt Output Pin.
P5.3/RD#	Read signal output to external memory. RD# is active only during external memory reads or LSIO when not used as RD#.
P5.2/WR#/WRL#	Write and Write Low output to external memory, as selected by the CCR, WR# goes low for every external write, while WRL# goes low only for external writes where an even byte is being written. WR#/WRL# is active during external memory writes. Also an LSIO pin when not used as WR#/WRL#.
P5.1/INST	Output high during an external memory read indicates the read is an instruction fetch. INST is valid throughout the bus cycle. INST is active only during external memory fetches, during internal EPROM fetches INST is held low. Also LSIO when not INST.
P5.0/ALE/ADV#	Address Latch Enable or Address Valid output, as selected by CCR. Both pin options provide a latch to demultiplex the address from the address/data bus. When the pin is ADV#, it goes inactive (high) at the end of the bus cycle. ADV# can be used as a chip select for external memory. ALE/ADV# is active only during external memory accesses. Also LSIO when not used as ALE.
PORT3 and 4	8-bit bidirectional I/O ports with open drain outputs. These pins are shared with the multiplexed address/data bus which has strong internal pullups.
P2.7/CLKOUT	Output of the internal clock generator. The frequency is the oscillator frequency. CLKOUT has a 50% duty cycle. Also LSIO pin when not used as CLKOUT.
P2.6/HLDA#	Bus Hold Acknowledge. Active-low output indicates that the bus controller has relinquished control of the bus. Occurs in response to an external device asserting the HLD# signal. Also LSIO when not used as HLDA#.
P2.5/HLD#	Bus Hold. Active-low signal indicates that an external device is requesting control of the bus. Also LSIO when not used as HLD#.
P2.4/INTOUT#	Interrupt Output. This active-low output indicates that a pending interrupt requires use of the external bus. Also LSIO when not used as INTOUT#.
P2.3/BREQ#	Bus Request. This active-low output signal is asserted during a HOLD cycle when the bus controller has a pending external memory cycle. Also LSIO when not used as BREQ#.
P2.2/EXTINT	A positive transition on this pin causes a maskable interrupt vector through memory location 203CH. Also LSIO when not used as EXTINT.
P2.1/RXD	Receive data input pin for the Serial I/O port. Also LSIO if not used as RXD.
P2.0/TXD	Transmit data output pin for the Serial I/O port. Also LSIO if not used as TXD.
PORT 1/EPA0-7	Dual-function I/O port pins. Primary function is that of bidirectional I/O. System function is that of High Speed capture and compare. EPA0 and EPA2 have another function of T2CLK and T2DIR of the TIMER2 timer/counter.
PORT 0/ACH0-7	8-bit high impedance input-only port. These pins can be used as digital inputs and/or as analog inputs to the on-chip A/D converter. These pins are also used as inputs to EPROM parts to select the Programming Mode.
EPORT	8-bit bidirectional standard and I/O Port. These bits are shared with the extended address bus, A16-A19 for CB PLCC, A16-A23 for CB QFP. Pin function is selected on a per pin basis.
TXCAN	Push-pull output to the CAN bus line.
RXCAN	High impedance input-only from the CAN bus line.

Table 4. 87C196CB Memory Map

Address	Description	Notes
FFFFFFH FF2080H	Program Memory - Internal EPROM or External Memory (Determined by EA# Pin)	
FF207FH FF2000H	Special Purpose Memory - Internal EPROM or External Memory (Determined by EA# Pin)	
FF1FFFH FF0600H	External Memory	
FF05FFFH FF0400H	Internal RAM (Identically Mapped into 00400H–005FFFH)	
FF03FFFH FF0100H	External Memory	
FF00FFFH FF0000H	Reserved for ICE	
FEFFFFH 0F0000H	Overlaid Memory (External)-Accesses into Memory Ranges 0F0000H to FEFFFFH will Overlay Page 15 (0FH) for CB QFP package-External Memory.	(5)
0EFFFFH 010000H	900 Kbytes External Memory	
00FFFFH 002080H	External Memory or Remapped OTPROM (Program Memory)	(1)
00207FH 002000H	External Memory or Remapped OTPROM (Special Purpose Memory)	(1,3)
001FFFH 001FE0H	Memory Mapped Special Function Registers (SFR's)	
001DFDH 001F00H	Internal Peripheral Special Function Registers (SFR's)	(5)
001EFFH 001E00H	Internal CAN Peripheral Memory	(5)
001DFFFH 001C00H	Internal Register RAM	
001BFFFH 000600H	External Memory	
0005FFFH 000400H	Internal RAM (Code RAM) (Address with Indirect or Indexed Modes)	
0003FFFH 000100H	Register RAM – Upper Register File (Address with Indirect or Indexed Modes or through Windows.)	(2)
0000FFFH 000018H	Register RAM – Lower Register File. (Address with Direct, Indirect, or Indexed Modes.)	(2)
000017H 000000H	CPU SFR's	(4)

NOTES:

1. These areas are mapped internal EPROM if the REMAP bit (CCB2.2) is set and EA# = 5 V. Otherwise they are external memory.
2. Code executed in locations 0000H to 003FFFH is forced external.
3. Reserved memory locations must contain 0FFH unless noted.
4. Reserved SFR bit locations must be written with 0.
5. Refer to *8XC196CB Supplement to 8xC196NT User's Manual* for SFR, CAN and Paging Descriptions.

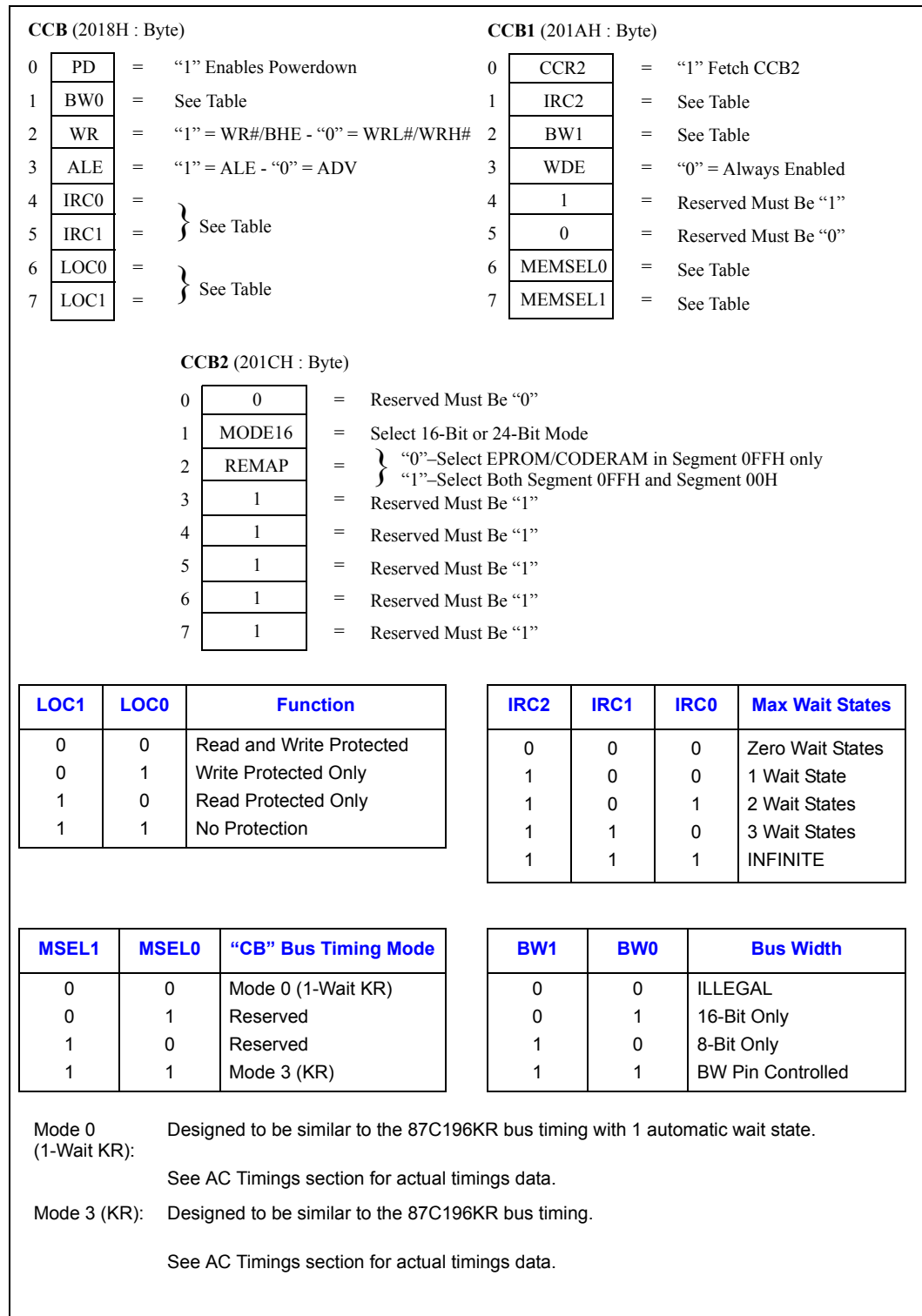
Figure 5. Chip Configuration Registers

5.0 Electrical Characteristics

ABSOLUTE MAXIMUM RATINGS*

Storage Temperature	-60°C to +150°C
Voltage from V _{PP} or EA# to V _{SS} or ANGND	-0.5 V to +13.0 V
Voltage from any other pin to V _{SS} or ANGND	-0.5 V to +7.0 V
This includes V _{PP} on ROM and CPU devices.	
Power Dissipation	1.0 W

OPERATING CONDITIONS

T _A (Ambient Temperature Under Bias)	-40°C to +125°C
V _{CC} (Digital Supply Voltage)	4.75 V to 5.25 V
V _{REF} (Analog Supply Voltage)	4.75 V to 5.25 V
F _{OSC} (Oscillator Frequency)	4 MHz to 20 MHz

NOTE: ANGND and V_{SS} should be nominally at the same potential.

NOTICE: This is a production data sheet. The specifications are subject to change without notice. Verify with your local Intel sales office that you have the latest datasheet before finalizing a design.

***WARNING:** Stressing the device beyond the "Absolute Maximum Ratings" may cause permanent damage. These are stress ratings only. Operation beyond the "Operating Conditions" is not recommended and extended exposure beyond the "Operating Conditions" may affect device reliability.

5.1 DC Characteristics

Table 5. DC Characteristics (Under Listed Operating Conditions) (Sheet 1 of 2)

Symbol	Parameter	Min	Typ	Max	Units	Test Conditions
I _{CC}	V _{CC} Supply Current (-40°C to +125°C Ambient)			100	mA	XTAL1 = 20 MHz V _{CC} = V _{PP} = V _{REF} = 5.25 V (While Device in Reset)
I _{REF}	A/D Reference Supply Current			5	mA	
I _{IDLE}	Idle Mode Current			35	mA	XTAL1 = 20 MHz V _{CC} = V _{PP} = V _{REF} = 5.25 V
I _{PD}	Powerdown Mode Current		50		µA	V _{CC} = V _{PP} = V _{REF} = 5.52 V (Notes 5,8)
V _{IL}	Input Low Voltage (All Pins)	-0.5		0.3 V _{CC}	V	For PORT0 (Note 7)
V _{IH}	Input High Voltage	0.7 V _{CC}		V _{CC} + 0.5	V	For PORT0 (Note 7)
V _{OL}	Output Low Voltage (Outputs Configured as Complementary)			0.3 0.45 1.5	V	I _{OL} = 200 µA (Note 3) I _{OL} = 3.2 mA I _{OL} = 7 mA
V _{OH}	Output High Voltage (Output Configured as Complementary)	V _{CC} - 0.3 V _{CC} - 0.7 V _{CC} - 1.5			V	I _{OH} = -200 µA (Note 3) I _{OH} = -3.2 mA I _{OH} = -7 mA
I _{LI}	Input Leakage Current (Standard Inputs)			±10	µA	V _{SS} < V _{IN} < V _{CC}

NOTES:

- All BD (bidirectional) pins except INST and CLKOUT. INST and CLKOUT are excluded due to not being weakly pulled high in reset. BD pins include Port1, Port2, Port3, Port4, Port5 and Port6 except SLPINT (P5.4) and HLDA# (P2.6).
- Standard Input pins include XTAL1, EA#, RESET# and Port 1/2/5/6 when setup as inputs.
- All Bidirectional I/O pins when configured as Outputs (Push/Pull).
- Device is Static and should operate below 1 Hz, but only tested down to 4 MHz.
- Typicals are based on limited number of samples and are not guaranteed. The values listed are at room temperature and V_{REF} = V_{CC} = 5 V.
- Violating these specifications in reset may cause the device to enter test mode (P5.4 and P2.6).
- When P0 is used as analog inputs, refer to A/D specifications for this characteristic.
- For temperatures < 100°C typical is 10 µA.

Table 5. DC Characteristics (Under Listed Operating Conditions) (Sheet 2 of 2)

Symbol	Parameter	Min	Typ	Max	Units	Test Conditions
I_{L11}	Input Leakage Current (Port 0)			± 1	μA	$V_{SS} < V_{IN} < V_{REF}$
V_{OH1}	SLPINT (P5.4) and HLDA# (P2.6) Output High Voltage in RESET#	2			V	$I_{OH} = 0.8 \text{ mA}$ (Note 6)
V_{OH2}	Output High Voltage in RESET#	$V_{CC} - 1$			V	$I_{OH} = -15 \mu A$ (Note 1)
C_S	Pin Capacitance (Any Pin to V_{SS})		10		pF	$F_{TEST} = 1 \text{ MHz}$ (Note 5)
R_{RST}	Reset Pullup Resistor	65 K		180 K	Ω	
R_{WPU}	Weak Pullup Resistance		150 K		Ω	(Note 5)

NOTES:

1. All BD (bidirectional) pins except INST and CLKOUT. INST and CLKOUT are excluded due to not being weakly pulled high in reset. BD pins include Port1, Port2, Port3, Port4, Port5 and Port6 except SLPINT (P5.4) and HLDA# (P2.6).
2. Standard Input pins include XTAL1, EA#, RESET# and Port 1/2/5/6 when setup as inputs.
3. All Bidirectional I/O pins when configured as Outputs (Push/Pull).
4. Device is Static and should operate below 1 Hz, but only tested down to 4 MHz.
5. Typicals are based on limited number of samples and are not guaranteed. The values listed are at room temperature and $V_{REF} = V_{CC} = 5 \text{ V}$.
6. Violating these specifications in reset may cause the device to enter test mode (P5.4 and P2.6).
7. When P0 is used as analog inputs, refer to A/D specifications for this characteristic.
8. For temperatures $< 100^\circ C$ typical is $10 \mu A$.

Figure 6. 87C196CB I_{CC} vs Frequency

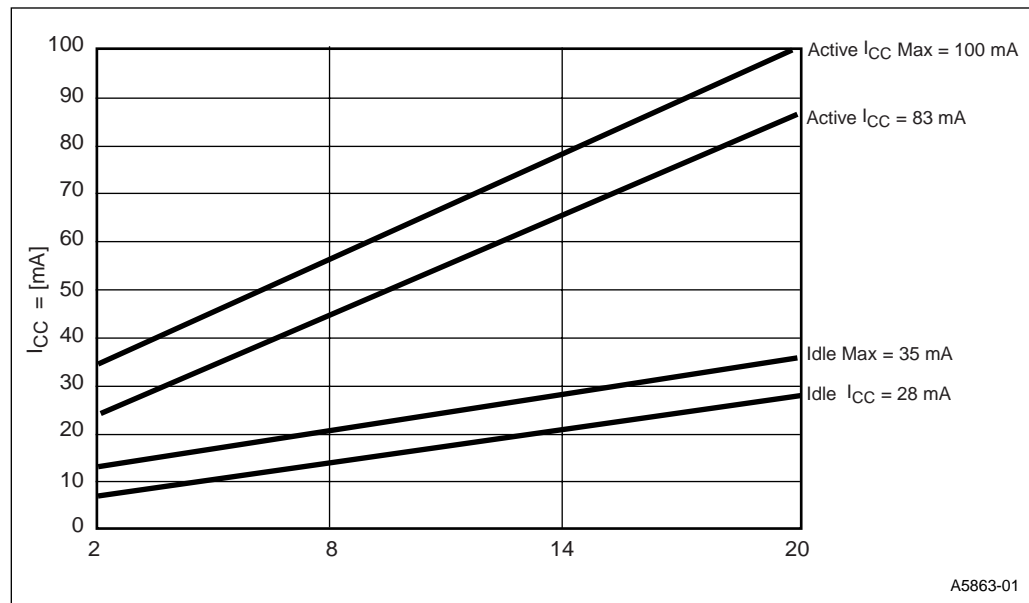

5.1.1 87C196CB - Automotive Additional Bus Timing Modes

The 87C196CB - Automotive device has two bus timing modes for external memory interfacing.

5.1.1.1 MODE 3

Mode 3 is the standard timing mode. Use this mode for systems that emulate the 87C196KR bus timings.

5.1.1.2 MODE 0

Mode 0 is the standard timing mode, but 1 (minimum) wait state is always inserted in external bus cycles.

5.2 AC Characteristics

5.2.1 Test Conditions

- Capacitive load on all pins = 100 pF
- Rise and Fall Times = 10 ns

Table 6. AC Characteristics (Over Specified Operating Conditions) (Sheet 1 of 2)

Symbol	Parameter	Min	Max	Units
The 87C196CB - Automotive Will Meet These Specifications				
F _{XTAL}	Frequency on XTAL1	4	20	MHz (1)
T _{OSC}	XTAL1 Period (1/F _{XTAL})	50	250	ns
T _{XHCH}	XTAL1 High to CLKOUT High or Low	20	110	ns
T _{OFD}	Clock Failure to Reset Pulled Low	4	40	μs (6)
T _{CLCL}	CLKOUT Period	2T _{OSC}		ns (2)
T _{CHCL}	CLKOUT High Period	T _{OSC} -10	T _{OSC} +15	ns
T _{CLLH}	CLKOUT Low to ALE/ADV High	-15	10	ns
T _{LLCH}	ALE/ADV# Low to CLKOUT High	-20	15	ns
T _{LHLH}	ALE/ADV# Cycle Time	4T _{OSC}		ns (2,5)
T _{LHLL}	ALE/ADV# High Time	T _{OSC} -10	T _{OSC} +10	ns
T _{AVLL}	Address Valid to ALE Low	T _{OSC} -15		ns
T _{LLAX}	Address Hold after ALE/ADV# Low	T _{OSC} -40		ns

NOTES:

1. Testing performed at 4 MHz, however, the device is static by design and typically operates below 1 Hz.
2. Typical specifications, not guaranteed.
3. Assuming back-to-back bus cycles.
4. 8-bit bus only.
5. If wait states are used, add 2T_{OSC} x n = number of wait states. If mode 0 (1 automatic wait state added) operation is selected, add 2T_{OSC} to specification.
6. T_{OFD} is the time for the oscillator fail detect circuit (OFD) to react to a clock failure. The OFD circuitry is enabled by programming the UPROM location 0778H with the value 0004H. Programming the CDE bit enables oscillator fail detection.

Table 6. AC Characteristics (Over Specified Operating Conditions) (Sheet 2 of 2)

Symbol	Parameter	Min	Max	Units
T_{LLRL}	ALE/ADV# Low to RD# Low	$T_{OSC}-30$		ns
T_{RLCL}	RD Low to CLKOUT Low	-8	20	ns
T_{RLRH}	RD# Low Period	$T_{OSC}-10$		ns (5)
T_{RHLH}	RD# High to ALE/ADV# High	T_{OSC}	$T_{OSC}+25$	ns (3)
T_{RLAZ}	RD# Low to Address Float		5	ns
T_{LLWL}	ALE/ADV# Low to WR# Low	$T_{OSC}-10$		ns
T_{CLWL}	CLKOUT Low to WR# Low	-5	25	ns
T_{QVWH}	Data Valid before WR# High	$T_{OSC}-23$		ns
T_{CHWH}	CLKOUT High to WR# High	-10	15	ns
T_{WLWH}	WR# Low Period	$T_{OSC}-20$		ns (5)
T_{WHQX}	Data Hold after WR# High	$T_{OSC}-25$		ns
T_{WHLH}	WR# High to ALE/ADV# High	$T_{OSC}-10$	$T_{OSC}+15$	ns (3)
T_{WHBX}	BHE#, INST Hold after WR# High	$T_{OSC}-10$		ns
T_{WHAX}	AD8-15 Hold after WR# High	$T_{OSC}-30$		ns (4)
T_{RHBX}	BHE#, INST Hold after RD# High	$T_{OSC}-10$		ns
T_{RHAX}	AD8-15 Hold after RD# High	$T_{OSC}-30$		ns (4)

NOTES:

1. Testing performed at 4 MHz, however, the device is static by design and typically operates below 1 Hz.
2. Typical specifications, not guaranteed.
3. Assuming back-to-back bus cycles.
4. 8-bit bus only.
5. If wait states are used, add $2T_{OSC} \times n$ = number of wait states. If mode 0 (1 automatic wait state added) operation is selected, add $2T_{OSC}$ to specification.
6. T_{OFD} is the time for the oscillator fail detect circuit (OFD) to react to a clock failure. The OFD circuitry is enabled by programming the UPROM location 0778H with the value 0004H. Programming the CDE bit enables oscillator fail detection.

Table 7. AC Characteristics (Over Specified Operating Conditions)

Symbol	Parameter	Min	Max	Units
The System Must Meet These Specifications to work with the 87C196CB - Automotive				
T_{AVYV}	Address Valid to READY Setup		$2 T_{OSC-75}$	ns (3)
T_{LLYV}	ALE Low to READY Setup		$2 T_{OSC-70}$	ns (3)
T_{YLYH}	Non Ready Time	No Upper Limit		ns
T_{CLYX}	READY Hold after CLKOUT Low	0	T_{OSC-30}	ns (1)
T_{AVGV}	Address Valid to BUSWIDTH Setup		$2 T_{OSC-75}$	ns (2,3)
T_{LLGV}	ALE Low to BUSWIDTH Setup		T_{OSC-60}	ns (2,3)
T_{CLGX}	BUSWIDTH Hold after CLKOUT Low	0		ns
T_{AVDV}	Address Valid to Input Data Valid		$3T_{OSC-55}$	ns (2)
T_{RLDV}	RD# Active to Input Data Valid		T_{OSC-30}	ns (2)
T_{CLDV}	CLKOUT Low to Input Data Valid		T_{OSC-50}	ns
T_{RHDZ}	End of RD# to Input Data Float		T_{OSC}	ns
T_{RHDX}	Data Hold after RD# High	0		ns

NOTES:

- 1.If Maximum is exceeded, additional wait states will occur.
- 2.If wait states are used, add $2 T_{OSC} \times n$, where n = number of wait states.
- 3.If mode 0 is selected, one wait state minimum is always added. If additional wait states are required, add $2 T_{OSC}$ to the specification.

5.2.2 87C196CB - Automotive Timings

Figure 7. 87C196CB - Automotive System Bus Timing

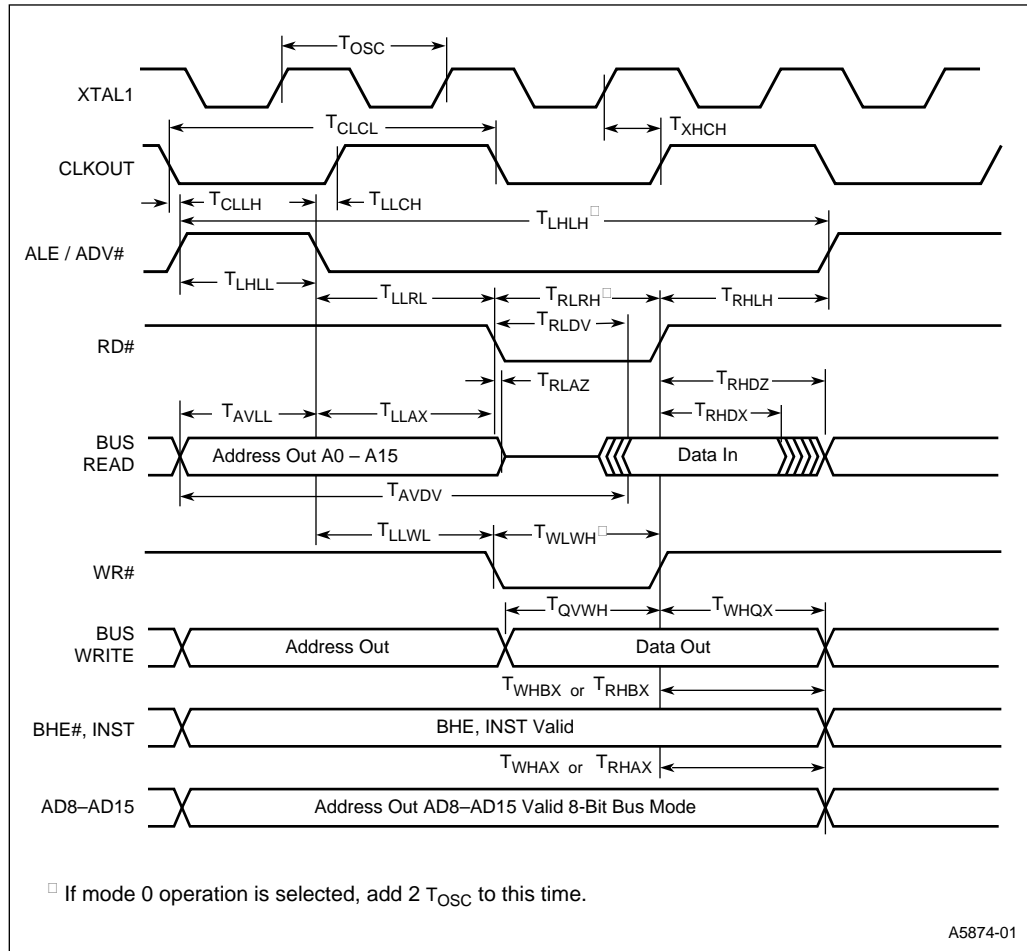
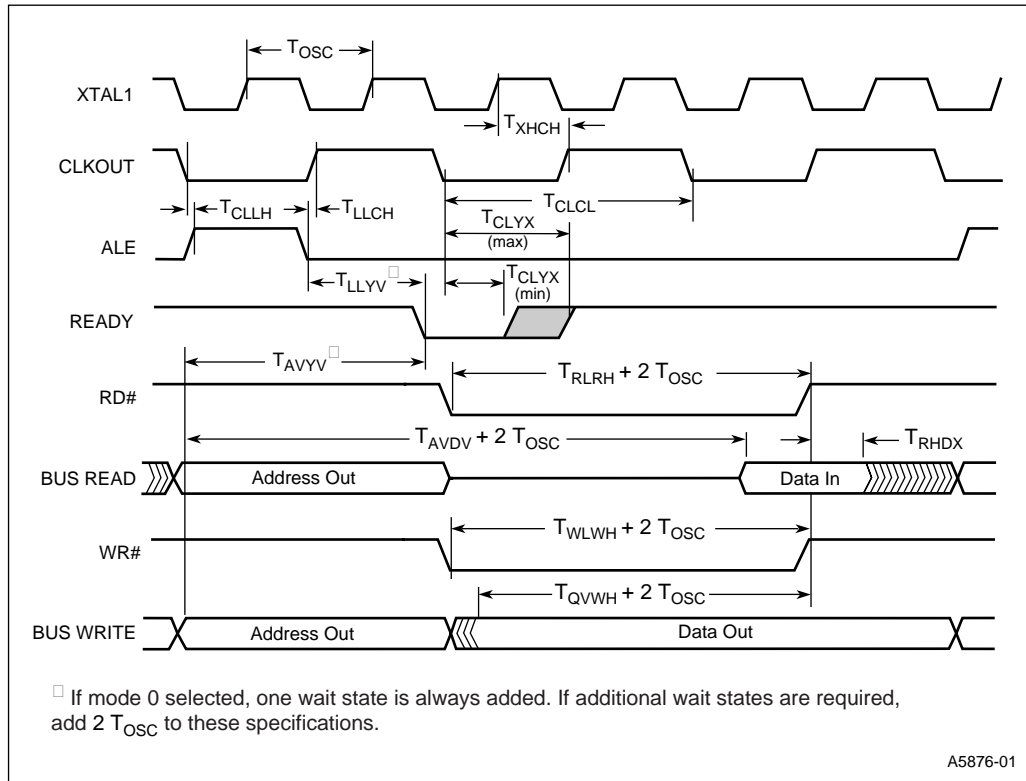
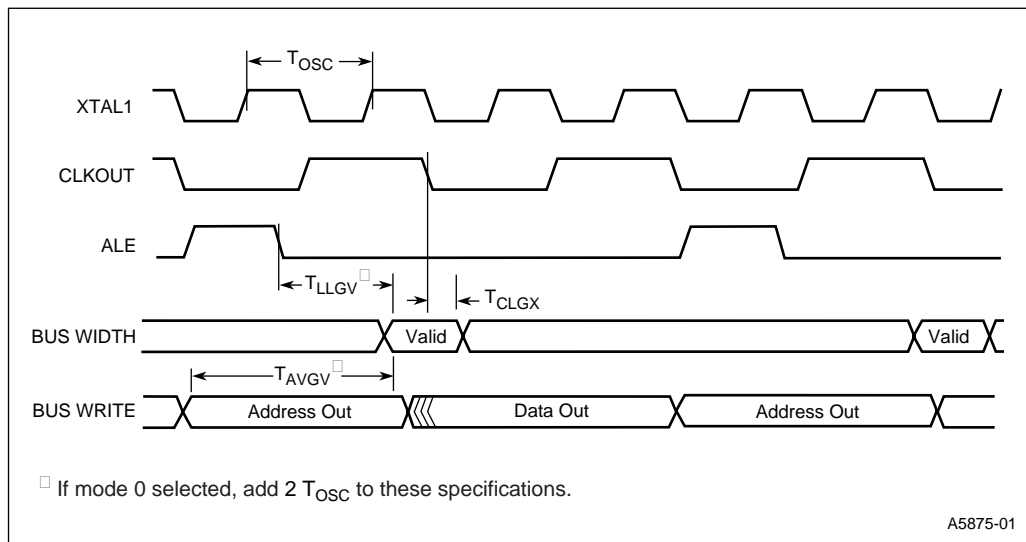

Figure 8. 87C196CB - Automotive Ready Timings (One Wait State)



5.2.3 87C196CB Timings

Figure 9. 87C196CB Buswidth Timings



5.2.4 87C196CB - Automotive Timings

Table 8. 8x196CB HOLD#/HOLDA# Timings (Over Specified Operation Conditions)

Symbol	Parameter	Min	Max	Units
T_{HVCH}	HOLD Setup Time	65		ns (1)
T_{CLHAL}	CLKOUT Low to HLDA Low	-15	15	ns
T_{CLBRL}	CLKOUT Low to BREQ Low	-15	15	ns
T_{AZHAL}	HLDA Low to Address Float		20	ns
T_{BZHAL}	HLDA Low to BHE#, INST, RD#, WR# Weakly Driven		25	ns
T_{CLHAH}	CLKOUT Low to HLDA High	-15	15	ns
T_{CLBRH}	CLKOUT Low to BREQ High	-25	25	ns
T_{HAHAX}	HLDA High to Address No Longer Float	-15		ns
T_{HAHBV}	HLDA High to BHE#, INST, RD#, WR# Valid	-10	15	ns

NOTE:

1. To guarantee recognition at next clock.

Figure 10. 87C196CB HOLD#/HOLDA# Timings

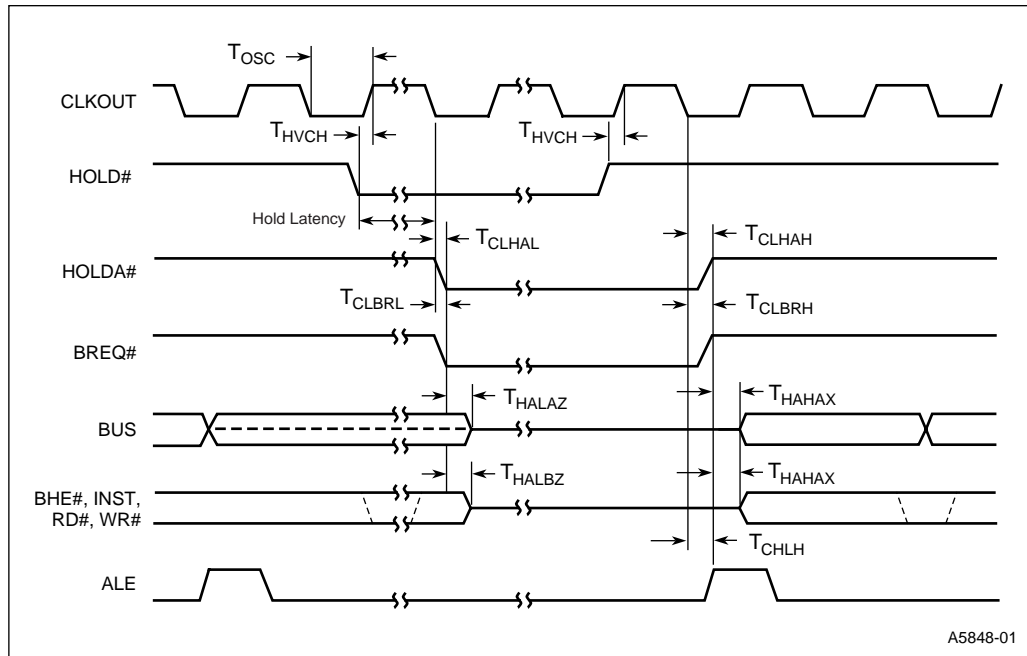

A5848-01

5.2.5 87C196CB - Automotive AC Characteristics - Slave Port

Figure 11. Slave Port Waveform - (SLPL = 0)

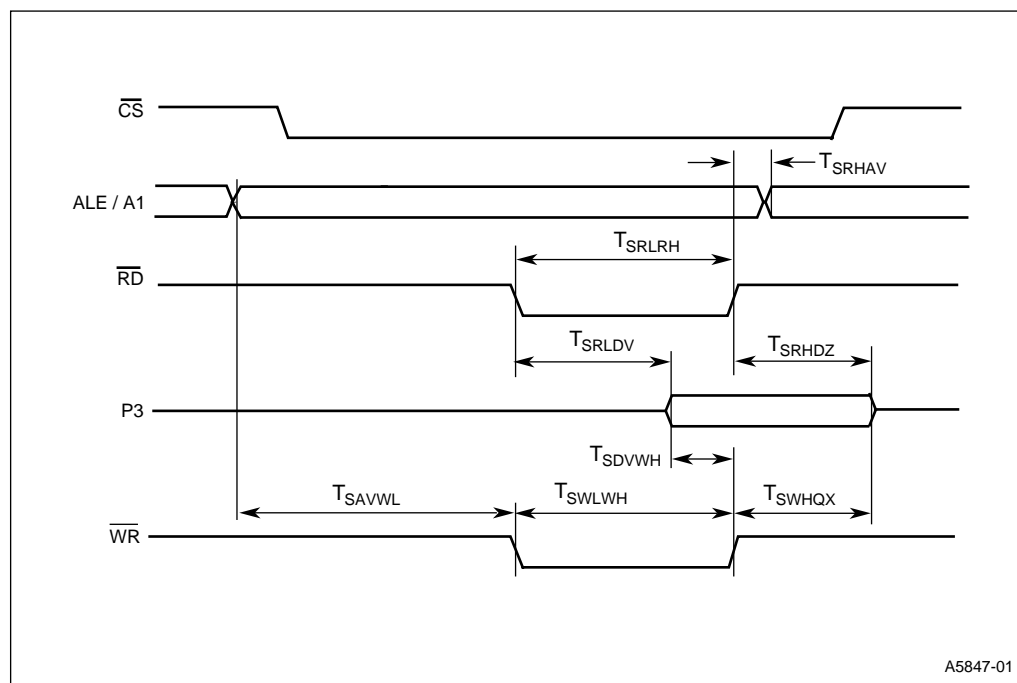

Table 9. Slave Port Timing - (SLPL = 0, 1, 2, 3)

Symbol	Parameter	Min	Max	Units
T_{SAVWL}	Address Valid to WR# Low	50		ns
T_{SRHAV}	RD# High to Address Valid	60		ns
T_{SRLRH}	RD# Low Period	T_{OSC}		ns
T_{SWLWH}	WR# Low Period	T_{OSC}		ns
T_{SRLDV}	RD# Low to Output Data Valid		60	ns
T_{SDVWH}	Input Data Setup to WR# High	20		ns
T_{SWHQX}	WR# High to Data Invalid	30		ns
T_{SRHDZ}	RD# High to Data Float	15		ns

NOTE:

- Test Conditions:
 - $F_{OSC} = 20$ MHz
 - $T_{OSC} = 60$ ns
 - Rise/Fall Time = 10 ns
 - Capacitive Pin Load = 100 pF
- These values are not tested in production, and are based upon theoretical estimates and/or laboratory tests.

Figure 12. Slave Port Waveform - (SLPL = 1)

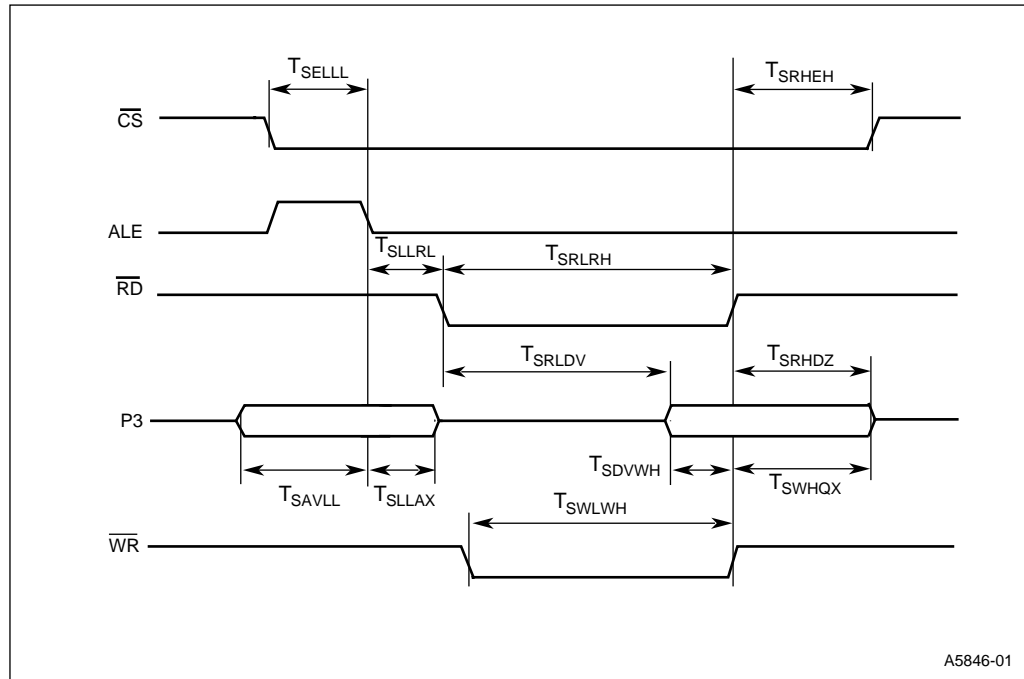

Table 10. Slave Port Timing - (SLPL = 1, 2, 3)

Symbol	Parameter	Min	Max	Units
T_{SELL}	CS# Low to ALE Low	20		ns
T_{SRHEH}	RD# or WR# High to CS# High	60		ns
T_{SLLRL}	ALE Low to RD# Low	T_{OSC}		ns
T_{SRLRH}	RD# Low Period	T_{OSC}		ns
T_{SWLWH}	WR# Low Period	T_{OSC}		ns
T_{SAVLL}	Address Valid to ALE Low	20		ns
T_{SLLAX}	ALE Low to Address Invalid	20		ns
T_{SRLDV}	RD# Low to Output Data Valid		60	ns
T_{SDVWH}	Input Data Setup to WR# High	20		ns
T_{SWHQX}	WR# High to Data Invalid	30		ns
T_{SRHDZ}	RD# High to Data Float	15		ns

NOTE:

1. Test Conditions:

- $F_{OSC} = 20$ MHz
- $T_{OSC} = 60$ ns
- Rise/Fall Time = 10 ns
- Capacitive Pin Load = 100 pF

2. These values are not tested in production, and are based upon theoretical estimates and/or laboratory tests.

Table 11. Normal Master/Slave Operation

Symbol	Parameter	Min (1)	Max	Units
T_{CHCH}	Clock Period	4t		ns
T_{CLCH}	Clock Low Time/Clock High Time	2t-10		ns
T_{CLDV}	Clock Falling to Data Out Valid (Master)	0.5t	1.5t + 20	ns
T_{CLDV1}	Clock Falling to Data Out Valid (Slave)	0.5t	1.5t + 50	ns
T_{DVCH}	Data In Setup to Clock Rising Edge	10		ns
T_{CHDX}	Clock Rising Edge to Data In Invalid	t + 15		ns

NOTE:
 1. t = 1 state time (100 ns @ 20 MHz).
 2. Timings are guaranteed by design.

Table 12. Handshake Operation

Symbol	Parameter	Min (1)	Max	Units
T_{CHCH}	Clock Period	4t		ns
T_{CLCH}	Clock Low Time/Clock High Time	2t-10		ns (2)
T_{CLDV}	Clock Falling to Data Out Valid (Master)	0.5t	1.5t + 20	ns
T_{CLDV1}	Clock Falling to Data Out Valid (Slave)	0.5t	1.5t + 20	ns
T_{DVCH}	Data In Setup to Clock Rising Edge	10		ns
T_{CHDX}	Clock Rising Edge to Data In Invalid	t + 15		ns

NOTE:
 1. t = 1 state time (100 ns @ 20 MHz).
 2. This specification refers to input clocks during slave operation. During master operation, the device outputs a nominal 50% duty cycle clock.

Figure 13. Synchronous Serial Port

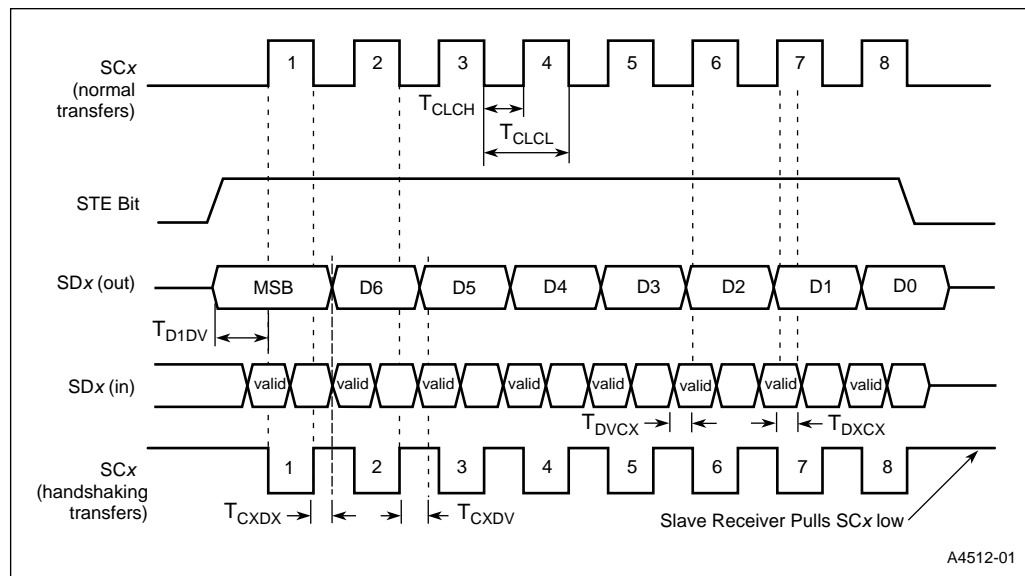

Table 13. External Clock Drive

Symbol	Parameter	Min (1)	Max	Units
$1/T_{XLXL}$	Oscillator Frequency	4	20	MHz
T_{XLXL}	Oscillator Period (T_{OSC})	50	250	ns
T_{XHXX}	High Time	$0.35 T_{OSC}$	$0.65 T_{OSC}$	ns
T_{XLXX}	Low Time	$0.35 T_{OSC}$	$0.65 T_{OSC}$	ns
T_{XLXH}	Rise Time		10	ns
T_{XHXL}	Fall Time		10	ns

Figure 14. External Clock Drive Waveforms

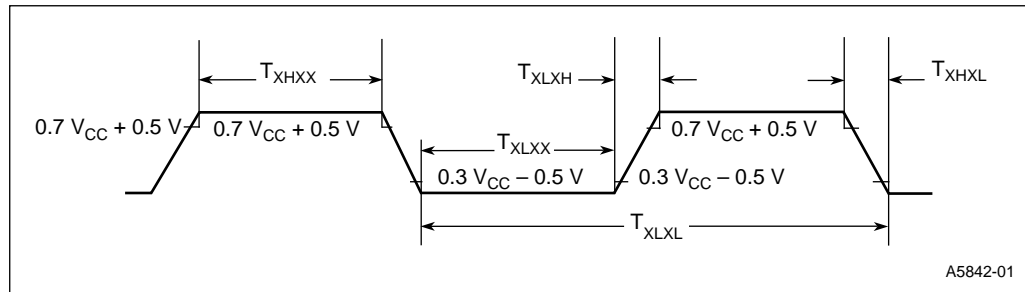

Figure 15. Input/Output Test Conditions

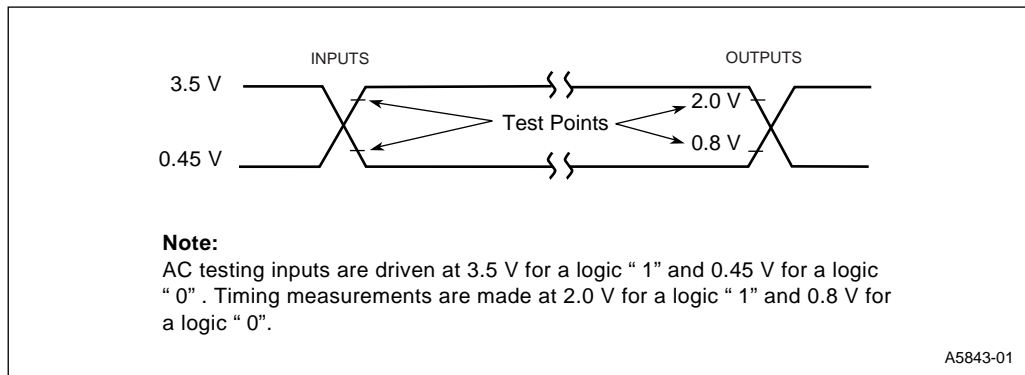
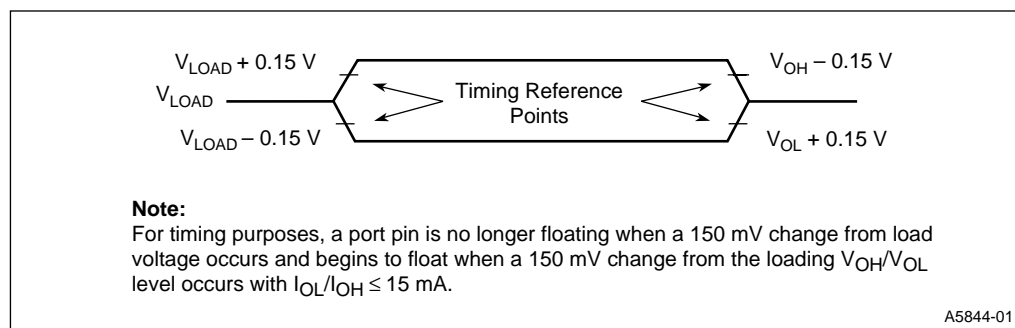

Figure 16. Float Test Conditions



5.2.6 Explanation of AC Symbols

Each symbol is two pairs of letters prefixed by “T” for time. The characters in a pair indicate a signal and its condition, respectively. Symbols represent the time between the two signal/condition points.

Table 14. Explanation of AC Symbols

Conditions	Signals	
H – High	A – Address	HA – HLDA#
L – Low	B – BHE#	L – ALE/ADV#
V – Valid	BR – BREQ#	Q – Data Out
X – No Longer Valid	C – CLKOUT	R – RD#
Z – Floating	D – DATA	W – WR#/WRH#/WRI#
	G – Buswidth	X – XTAL1
	H – HOLD#	Y – READY

5.3 EPROM Specifications

5.3.1 AC EPROM Programming Characteristics

Operating Conditions:

- Load Capacitance = 150 pF
- $V_{CC} = 5.0 \text{ V} \pm 0.25 \text{ V}$
- $V_{SS} = 0 \text{ V}$
- $T_C = 25^\circ\text{C} \pm 5^\circ\text{C}$
- $ANGND = 0 \text{ V}$
- $EA\# = 12.5 \text{ V} \pm 0.25 \text{ V}$
- $V_{REF} = 5.0 \text{ V} \pm 0.25 \text{ V}$
- $V_{PP} = 12.5 \text{ V} \pm 0.25 \text{ V}$
- $F_{OSC} = 5.0 \text{ MHz}$

Table 15. AC EPROM Programming Characteristics (Sheet 1 of 2)

Symbol	Parameter	Min	Max	Units
T_{AVLL}	Address Setup Time	0		T_{OSC}
T_{LLAX}	Address Hold Time	100		T_{OSC}
T_{DVPL}	Data Setup Time	0		T_{OSC}

Table 15. AC EPROM Programming Characteristics (Sheet 2 of 2)

Symbol	Parameter	Min	Max	Units
T _{PLDX}	Data Hold Time	400		T _{OSC}
T _{LLLH}	PALE# Pulse Width	50		T _{OSC}
T _{PLPH}	PROG# Pulse Width (2)	100		T _{OSC}
T _{LHPL}	PALE# High to PROG# Low	220		T _{OSC}
T _{PHLL}	PROG# High to Next PALE# Low	220		T _{OSC}
T _{PHDX}	Word Dump Hold Time		50	T _{OSC}
T _{PHPL}	PROG# High to Next PROG# Low	220		T _{OSC}
T _{LHPL}	PALE# High to PROG# Low	220		T _{OSC}
T _{PLDV}	PROG# Low to Word Dump Valid		100	T _{OSC}
T _{SHLL}	RESET# High to First PALE# Low	1100		T _{OSC}
T _{PHIL}	PROG# High to AINC# Low	0		T _{OSC}
T _{ILIH}	AINC# Pulse Width	240		T _{OSC}
T _{ILVH}	PVER Hold after AINC# Low	50		T _{OSC}
T _{ILPL}	AINC# Low to PROG# Low	170		T _{OSC}
T _{PHVL}	PROG# High to PVER# Valid		220	T _{OSC}

NOTES:

- 1.Run time programming is done with F_{OSC} = 6 MHz to 10 MHz, V_{CC}, V_{PD}, V_{REF} = 5 V ±0.25 V, T_C = 25°C ±5°C and V_{PP} = 12.5 V ± 0.25 V. For run-time programming over a full operating range, contact factory.
- 2.Programming Specifications are not tested, but guaranteed by design.
- 3.This specification is for the word dump mode. For programming pulses use 300 T_{OSC} + 100 μs.

Table 16. DC EPROM Programming Characteristics

Symbol	Parameter	Min	Max	Units
I _{PP}	V _{PP} Programming Supply Current		200	mA

NOTE: V_{PP} must be within 1 V of V_{CC} while V_{CC} < 4.5 V. V_{PP} must not have a low impedance path to ground or V_{SS} while V_{CC} > 4.5 V.

5.3.2 EPROM Programming Waveforms

Figure 17. Slave Programming Mode Data Program Mode with Single Program Pulse

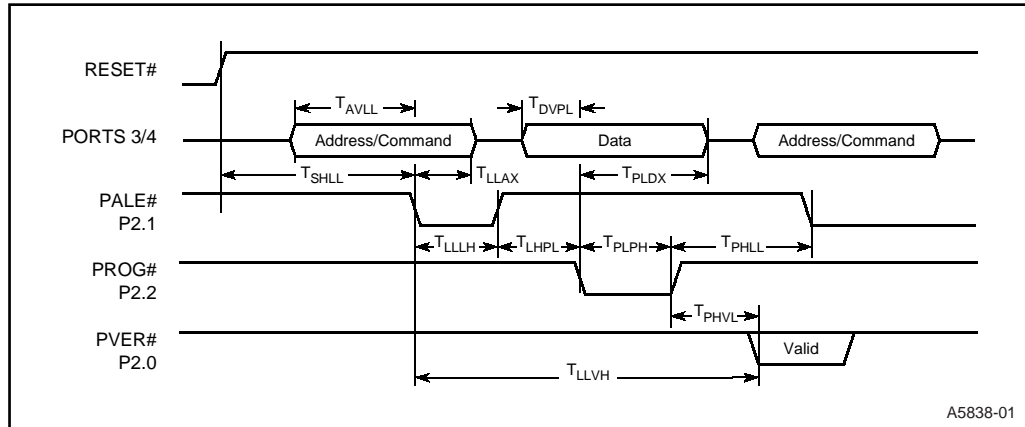

Figure 18. Slave Programming Mode in Word Dump or Data Verify Mode with Auto Increment

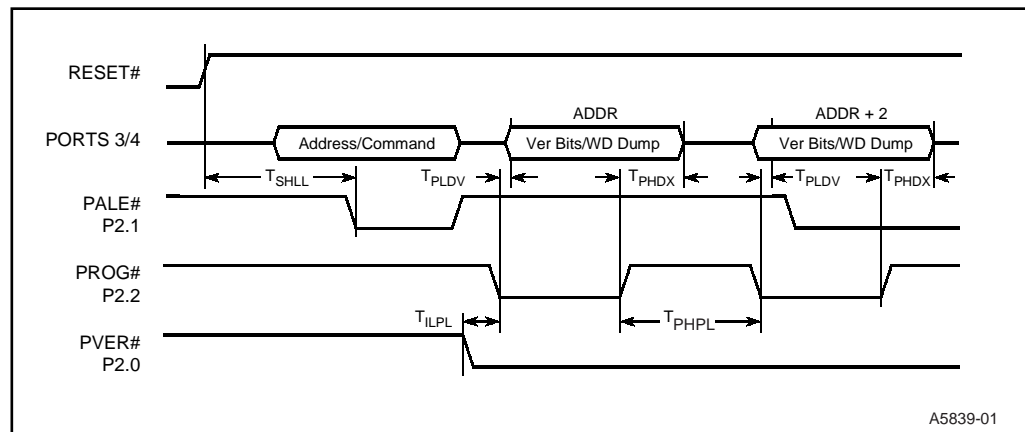
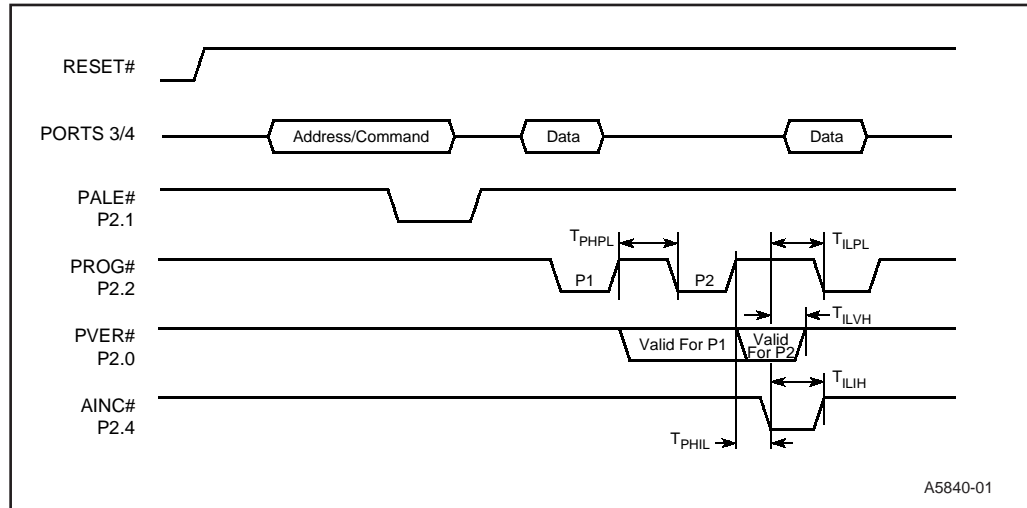

Figure 19. Slave Programming Mode Timing in Data Program Mode with Repeated Program Pulse and Auto Increment



A5840-01

5.4 AC Characteristics - Serial Port - Shift Register Mode

Operating Conditions:

- $T_A = -40^{\circ}\text{C} +125^{\circ}\text{C}$
- $V_{SS} = 0.0\text{ V}$
- $V_{CC} = 5.0\text{ V} \pm 5\%$
- Load Capacitance = 100 pF

Table 17. Serial Port Timing - Shift Register Mode

Symbol	Parameter	Min	Max	Units
T_{XLXL}	Serial Port Clock Period	$8 T_{OSC}$		ns
T_{XLXH}	Serial Port Clock Falling Edge to Rising Edge	$4 T_{OSC} - 50$	$4 T_{OSC} + 50$	ns
T_{QVXH}	Output Data Setup to Clock Rising Edge	$3 T_{OSC}$		ns
T_{XHQX}	Output Data Hold after Clock Rising Edge	$2 T_{OSC} - 50$		ns
T_{XHQV}	Next Output Data Valid after Clock Rising Edge		$2 T_{OSC} + 50$	ns
T_{DVXH}	Input Data Setup to Clock Rising Edge	$2 T_{OSC} + 200$		ns
T_{XHDX}	Input Data Hold after Clock Rising Edge	0		ns
T_{XHQZ}	Last Clock Rising to Output Float		$5T_{OSC}$	ns

NOTE:

1. Parameters not tested.

Figure 20. Waveform - Serial Port - Shift Register Mode

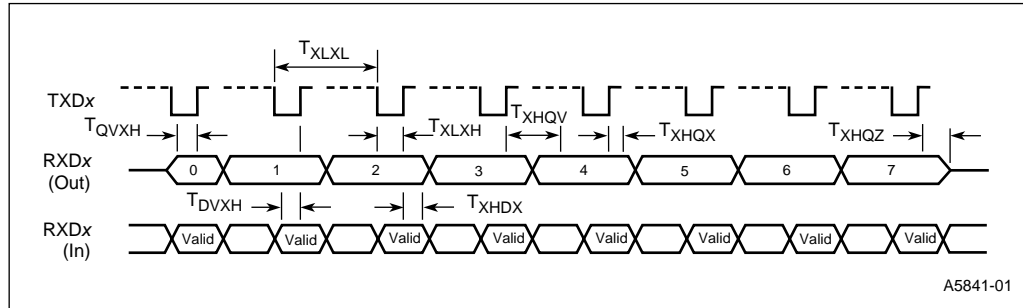

5.4.1 A/D Characteristics

The sample and conversion time of the A/D converter in the 8-bit or 10-bit modes is programmed by loading a byte into the AD_TIME Special Function Register. This allows optimizing the A/D operation for specific applications. The AD_TIME register is functional for all possible values, but the accuracy of the A/D converter is only guaranteed for the times specified in the operating conditions table.

The value loaded into AD_TIME bits 5, 6, 7 determines the sample time, SAMP. The value loaded into AD_TIME bits 0, 1, 2, 3 and 4 determines the bit conversion time, CONV. These bits, as well as the equation for calculating the total conversion time, T, are shown in Figure 21.

Figure 21. AD_TIME 1FAFH:Byte

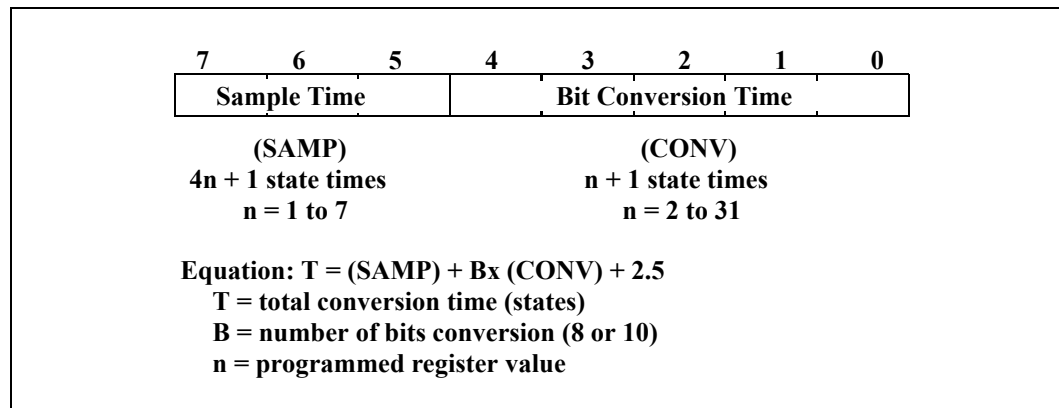

The converter is ratiometric, so absolute accuracy is dependent on the accuracy and stability of V_{REF} . V_{REF} must be close to V_{CC} since it supplies both the resistor ladder and the analog portion of the converter and input port pins. There is also an AD_TEST SFR that allows for conversion on ANGND and V_{REF} as well as adjusting the zero offset. The absolute error listed is without doing any adjustments.

5.4.1.1 A/D Converter Specification

The specifications given assume adherence to the operating conditions section of this data sheet. Testing is performed with $V_{REF} = 5.12$ V and 20 MHz operating frequency. After a conversion is started, the device is placed in IDLE mode until the conversion is complete.

Table 18. 10-Bit Mode A/D Operating Conditions

Symbol	Parameter	Min	Max	Units
T_A	Ambient Temperature	-40	+125	°C
V_{CC}	Digital Supply Voltage	4.75	5.25	V
V_{REF}	Analog Supply Voltage	4.75	5.25	V (1)
T_{SAM}	Sample Time	2		μs (2)
T_{CONV}	Conversion Time	15	18	μs (2)
F_{OSC}	Oscillator Frequency	4	20	MHz

NOTES:

1. V_{REF} must be within +0.5 V of V_{CC} .
2. The value of AD_TIME is selected to meet these specifications.

Table 19. 10-Bit Mode A/D Characteristics (Using Above Operating Conditions) (1)

Parameter	Typical (2,3)	Min	Max	Units (4)	Notes
Resolution		1024 10	1024 10	Levels Bits	
Absolute Error		0	± 3	LSBs	
Full-scale Error	0.25 ± 0.5			LSBs	
Zero Offset Error	0.25 ± 0.5			LSBs	
Non-Linearity	1 ± 2		± 3	LSBs	
Differential Non-Linearity		> -0.75	$+0.75$	LSBs	
Channel-to-Channel Matching	± 0.1	0	± 1	LSBs	
Repeatability	± 0.25	0		LSBs	(2)
Temperature Coefficients: Offset Fullscale Differential Non-Linearity	0.009			LSB/C	(2)
Off Isolation		-60		dB	(2,5,6)
Feedthrough	-60			dB	(2,5)
V _{CC} Power Supply Rejection	-60			dB	(2,5)
Input Resistance		750	1.2 K	Ω	(8)
DC Input Leakage	± 1	-3	3	μA	
Voltage on Analog Input Pin		ANGND -0.5	V _{REF} + 0.25	V	(7)
Sampling Capacitor	3			pF	

NOTES:

- All conversions performed with processor in IDLE mode.
- These values are expected for most parts at 25°C but are not tested or guaranteed.
- These values are not tested in production and are based on theoretical estimates and/or laboratory test.
- An "LSB", as used here, has a value of approximately 5 mV
- DC to 100 KHz
- Multiplexer Break-Before-Make Guaranteed.
- Applying voltages beyond these specifications will degrade the accuracy of other channels being converted.
- Resistance from device pin, through internal MUX, to sample capacitor.

Table 20. 8-Bit Mode A/D Operating Conditions

Symbol	Parameter	Min	Max	Units
T _A	Ambient Temperature	-40	+125	°C
V _{CC}	Digital Supply Voltage	4.75	5.25	V
V _{REF}	Analog Supply Voltage	4.75	5.25	V (1)
T _{SAM}	Sample Time	2		μs (2)
T _{CONV}	Conversion Time	12	15	μs (2)
F _{OSC}	Oscillator Frequency	4	20	MHz

NOTES:

- V_{REF} must be within +0.5 V of V_{CC}.
- The value of AD_TIME is selected to meet these specifications.

Table 21. 8-Bit Mode A/D Characteristics (Using Above Operating Conditions) (1)

Parameter	Typical (2,3)	Min	Max	Units (4)	Notes
Resolution		256 8	256 8	Levels Bits	
Absolute Error		0	± 1	LSBs	
Full-scale Error	± 0.5			LSBs	
Zero Offset Error	± 0.5			LSBs	
Non-Linearity		0	± 1	LSBs	
Differential Non-Linearity		- 0.5	+ 0.5	LSBs	
Channel-to-Channel Matching		0	± 1	LSBs	
Repeatability	± 0.25	0		LSBs	(2)
Temperature Coefficients: Offset Fullscale Differential Non-Linearity	0.003			LSB/C	(2)
Off Isolation		- 60		dB	(2,5,6)
Feedthrough	- 60			dB	(2,5)
V _{CC} Power Supply Rejection	- 60			dB	(2,5)
Input Resistance		750	1.2 K	Ω	(8)
DC Input Leakage	± 1	- 1.5	1.5	μA	
Voltage on Analog Input Pin		ANGND -0.5	V _{REF} + 0.25	V	(7)
Sampling Capacitor	3			pF	

NOTES:

1. All conversions performed with processor in IDLE mode.
2. These values are expected for most parts at 25°C but are not tested or guaranteed.
3. These values are not tested in production and are based on theoretical estimates and/or laboratory test.
4. An "LSB", as used here, has a value of approximately 5 mV
5. DC to 100 KHz
6. Multiplexer Break-Before-Make Guaranteed.
7. Applying voltages beyond these specifications will degrade the accuracy of other channels being converted.
8. Resistance from device pin, through internal MUX, to sample capacitor.

6.0 Datasheet Revision History

This is the -007 revision of the 87C196CB - *Automotive* datasheet. The following differences exist between the -008 and the -007 revision.

1. To address the fact that many of the package prefix variables have changed, all package prefix variables in this document are now indicated with an "x".

This is the -006 revision of the 87C196CB - *Automotive* datasheet. The following differences exist between the -005 and the -006 revision.

1. Figure 4: Added - "P5.3/" to Pin 77. Removed "P5.3/" from Pin 76.
2. Table 4 - V_{OH1} : Changed - Max value (was 2, now blank) to Min value (was blank, now 2).

This is the -005 revision of the 87C196CB - *Automotive* datasheet. The following differences exist between the -004 and the -005 revision.

1. Converted to new template.
2. Corrected grammar.
3. Moved first page talbe and text paragraph to Introduction section.
4. Changed operating supply voltage specifications from 10% to 5%.
5. Removed all references to 87C196CA from data sheet.
6. Changed from "Advance Information" to "Production" data sheet.

This is the -003 revision of the 87C196CB - *Automotive* data sheet. The following differences exist between the -002 version and the -003 revision.

1. The data sheet has been revised to ADVANCE from PRELIMINARY, indicating the specifications have been verified through electrical tests.
2. The 87C196CB 100-ld QFP package and device pinout has been added to the data sheet.
3. The 87C196CB 100-ld QFP device supports up the 16 Mbyte of linear address space.
4. The package thermal characteristics for the PLCC packages was added to the data sheet, for the CB $\Theta_{JA} = 35.0^{\circ}\text{C}/\text{W}$, $\Theta_{JC} = 11.0^{\circ}\text{C}/\text{W}$. For the CA, $\Theta_{JA} = 36.5^{\circ}\text{C}/\text{W}$ and $\Theta_{JA} = 10.0^{\circ}\text{C}/\text{W}$.
5. The AN87C196CB pin package diagram was corrected to show EA# as opposed to EA.
6. The REMAP bit function for CCB2 was corrected. Setting this bit to 0 selects EPROM/CODERAM in segment 0FFH only. Setting this bit to 1 selects both segment 0FFH and segment 00H.
7. T_{RLAZ} has been changed to 5 ns from 20 ns.
8. T_{WLWH} for the CA has been changed to $T_{OSC} - 20$ from $T_{OSC} - 30$.
9. T_{CLGX} has been changed to 0 ns min, from $T_{OSC} - 46$ max.
10. . Timing specifications for the SSIO are now added. These timings are currently guaranteed by design.
11. . Added frequency designation to family nomenclature Figure 2.

This is the -002 revision of the 87C196CA data sheet. The following difference exist between the -001 version and the -002 revision.

1. This data sheet now includes the specifications for the 87C196CB as well as the 87C196CA.

2. ABSOLUTE MAXIMUM RATINGS have been added.
3. Maximum Frequency has been increased to 20 MHz.
4. Maximum I_{CC} has been increased from 75 mA to 100 mA for the CB, 90 mA for the CA.
5. Idle Mode current has been increased to 35 mA from 30 mA for the CB, 40 mA for the CA.
6. Input leakage current for Port 0 (I_{LH}) was decreased to 1.5 μ A from 2.0 μ A for the CA.
7. The electrical characteristics for the CAN module were removed. The electrical characteristics for TXCAN and RXCAN are identical to standard port pins.
8. T_{OSC} (1/freq) was modified to reflect 20 Mhz timings.
9. T_{OFD} (Oscillator Fail Detect Specification) for clock failure to RESET pin pulled low, was added to the data sheet (4 μ s min, 40 μ s max)
10. T_{WHQX} has been increased to $T_{OSC} - 25$ ns min from $T_{OSC} - 30$ ns min.
11. T_{RXDX} has been replaced by T_{RHDX} . T_{RLAZ} has been increased to 20 ns max from 5 ns max.
12. I_{PP} programming supply current has been increased to 200 mA from 100 mA.
13. T_{CONV} Conversion time for 10 bit A/D conversions has been decreased to reflect 20 Mhz operation.
14. R_{RST} was added for the 87C196CA, min = 6 K Ω /max = 65 K Ω
15. T_{CLLH} -min/max parameters switched to accurately reflect this timing parameter.
16. T_{RLCL} -Separate timings for the 87C196CA vs 87C196CB. T_{RLCL} for the CB is min -8 ns, max +20 ns. For the CA, T_{RLCL} min +4 ns/max +30 ns.
17. T_{RLRH} changed to $T_{OSC} - 10$ ns from $T_{OSC} - 5$ ns.
18. T_{AVGV} added for the 87C196CB.
19. T_{LLGV} added for the 87C196CB.
20. T_{CLGX} added for the 87C196CB.
21. T_{RLDV} -Separate timings for 87C196CB. T_{RLDV} max = $T_{OSC} - 30$ ns. For the 87C196CA, T_{RLDV} max = $T_{OSC} - 22$ ns.
22. HOLD/HOLDA timings added for the 87C196CB.
23. Slave Port Timings added for the 87C196CB.
24. Separate specifications for T_{PLPH} for the 87C196CB, T_{PLPH} min = 100 T_{OSC} . For the 87C196CA, T_{PLPH} min = 50 T_{OSC} .
25. Separate specifications for T_{PLDV} for the 87C196CB, T_{PLDV} min = 100 T_{OSC} for the 87C196CA, T_{PLDV} min = 50 T_{OSC} .
26. 8-Bit mode A/D characteristics added.

