



M29W128GH M29W128GL

128 Mbit (16 Mb x 8 or 8 Mb x 16, page, uniform block)
3 V supply Flash memory

Features

- Supply voltage
 - $V_{CC} = 2.7$ to 3.6 V for Program, Erase and Read
 - $V_{CCQ} = 1.65$ to 3.6 V for I/O buffers
 - $V_{PPH} = 12$ V for Fast Program (optional)
- Asynchronous Random/Page Read
 - Page size: 8 words or 16 bytes
 - Page access: 25, 30 ns
 - Random access: 60 (only available upon customer request) or 70, 80 ns
- Fast Program commands
 - 32 words (64-byte write buffer)
- Enhanced Buffered Program commands
 - 256 words
- Programming time
 - 16 μ s per byte/word typical
 - Chip program time: 5 s with V_{PPH} and 8 s without V_{PPH}
- Memory organization
 - M29128GH/L: 128 main blocks, 128 Kbytes/64 Kwords each
- Program/Erase controller
 - Embedded byte/word program algorithms
- Program/ Erase Suspend and Resume
 - Read from any block during Program Suspend
 - Read and Program another block during Erase Suspend
- Unlock Bypass/Block Erase/Chip Erase/Write to Buffer/Enhanced Buffered Program commands

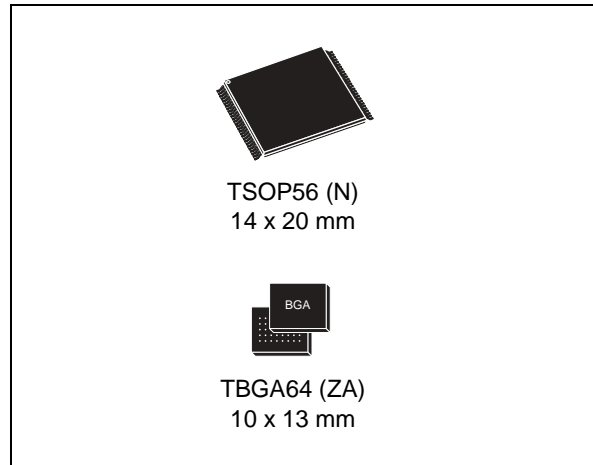

- Faster Production/Batch Programming
- Faster Block and Chip Erase
- V_{PP}/\overline{WP} pin for Fast Program and Write: protects first or last block regardless of block protection settings
- Software protection:
 - Volatile protection
 - Non-volatile protection
 - Password protection
- Common Flash interface
 - 64 bit security code
- 128 word extended memory block
 - Extra block used as security block or to store additional information
- Low power consumption
 - Standby and automatic standby
- Minimum 100,000 Program/Erase cycles per block
- ECOPACK® packages

Table 1. Device summary

Root part number	Device code
M29W128GH: uniform, last block protected by V_{PP}/\overline{WP}	227Eh + 2221h + 2201h
M29W128GL: uniform, first block protected by V_{PP}/\overline{WP}	227Eh + 2221h + 2200h

Contents

1	Description	8
2	Signal descriptions	13
2.1	Address inputs (A0-A22)	13
2.2	Data inputs/outputs (DQ0-DQ7)	13
2.3	Data inputs/outputs (DQ8-DQ14)	13
2.4	Data inputs/outputs or address inputs (DQ15A-1)	13
2.5	Chip Enable (\bar{E})	13
2.6	Output Enable (\bar{G})	13
2.7	Write Enable (\bar{W})	14
2.8	V_{PP} /Write Protect (V_{PP}/\bar{WP})	14
2.9	Reset (\bar{RP})	15
2.10	Ready/Busy output (\bar{RB})	15
2.11	Byte/word organization select (\bar{BYTE})	15
2.12	V_{CC} supply voltage	15
2.13	V_{CCQ} input/output supply voltage	15
2.14	V_{SS} ground	16
3	Bus operations	17
3.1	Bus Read	17
3.2	Bus Write	17
3.3	Output Disable	17
3.4	Standby	17
3.5	Reset	18
3.6	Automatic Standby	18
3.7	Auto Select mode	18
3.7.1	Read electronic signature	18
3.7.2	Verify extended memory block protection indicator	19
3.7.3	Verify block protection status	19
3.7.4	Hardware Block Protect	19
4	Hardware protection	23

5	Software protection	23
5.1	Volatile protection mode	24
5.2	Non-volatile protection mode	24
5.2.1	Non-volatile protection bits	24
5.2.2	Non-volatile Protection Bit Lock bit	25
5.3	Password protection mode	25
6	Command interface	27
6.1	Standard commands	27
6.1.1	Read/Reset command	27
6.1.2	Auto Select command	27
6.1.3	Read CFI Query command	28
6.1.4	Chip Erase command	28
6.1.5	Block Erase command	28
6.1.6	Erase Suspend command	29
6.1.7	Erase Resume command	30
6.1.8	Program Suspend command	30
6.1.9	Program Resume command	30
6.1.10	Program command	31
6.2	Fast Program commands	34
6.2.1	Write to Buffer Program command	34
6.2.2	Enhanced Buffered Program command	35
6.2.3	Buffered Program Abort and Reset command	36
6.2.4	Write to Buffer Program Confirm command	37
6.2.5	Enhanced Buffered Program Confirm command	37
6.2.6	Unlock Bypass command	37
6.2.7	Unlock Bypass Program command	37
6.2.8	Unlock Bypass Block Erase command	38
6.2.9	Unlock Bypass Chip Erase command	38
6.2.10	Unlock Bypass Write to Buffer Program command	38
6.2.11	Unlock Bypass Enhanced Buffered Program command	38
6.2.12	Unlock Bypass Reset command	39
6.3	Protection commands	42
6.3.1	Enter Extended Memory Block command	42
6.3.2	Exit Extended Memory Block command	42
6.3.3	Lock Register command set	43

6.3.4	Password Protection mode command set	43
6.3.5	Non-volatile Protection mode command set	44
6.3.6	NVPB Lock Bit command set	46
6.3.7	Volatile Protection mode command set	46
6.3.8	Exit Protection command set	46
7	Registers	51
7.1	Lock Register	51
7.1.1	Password Protection Mode Lock bit (DQ2)	51
7.1.2	Non-volatile Protection Mode Lock bit (DQ1)	51
7.1.3	Extended Block Protection bit (DQ0)	51
7.1.4	DQ15 to DQ3 reserved	51
7.2	Status Register	54
7.2.1	Data Polling bit (DQ7)	54
7.2.2	Toggle bit (DQ6)	54
7.2.3	Error bit (DQ5)	54
7.2.4	Erase Timer bit (DQ3)	55
7.2.5	Alternative Toggle bit (DQ2)	55
7.3	Buffered Program Abort bit (DQ1)	55
8	Maximum ratings	59
9	DC and AC parameters	60
10	Package mechanical	75
11	Ordering information	77
Appendix A	Block addresses and read/modify protection groups	78
Appendix B	Common Flash interface (CFI)	82
Appendix C	Extended memory block	87
C.1	Factory locked extended memory block	87
C.2	Customer lockable extended memory block	88
Appendix D	Flowcharts	89

12 **Revision history** **93**

List of tables

Table 1.	Device summary	1
Table 2.	Signal names	9
Table 3.	V_{PP}/\overline{WP} functions	14
Table 4.	Bus operations, 8-bit mode	20
Table 5.	Bus operations, 16-bit mode	20
Table 6.	Read electronic signature - auto select mode - programmer method (8-bit mode)	21
Table 7.	Read electronic signature - auto select mode - programmer method (16-bit mode)	21
Table 8.	Block protection - auto select mode - programmer method (8-bit mode)	22
Table 9.	Block protection - auto select mode - programmer method (16-bit mode)	22
Table 10.	Standard commands, 8-bit mode	32
Table 11.	Standard commands, 16-bit mode	33
Table 12.	Fast Program commands, 8-bit mode	40
Table 13.	Fast Program commands, 16-bit mode	41
Table 14.	Enhanced Buffered Program commands, 16-bit mode	41
Table 15.	Block Protection commands, 8-bit mode	47
Table 16.	Block Protection commands, 16-bit mode	49
Table 17.	Program, Erase times and Program, Erase endurance cycles	50
Table 18.	Lock Register bits	52
Table 19.	Block protection status	52
Table 20.	Status Register bits	56
Table 21.	Absolute maximum ratings	59
Table 22.	Operating and AC measurement conditions	60
Table 23.	Power-up waiting timings	61
Table 24.	Device capacitance	62
Table 25.	DC characteristics	62
Table 26.	Read AC characteristics	65
Table 27.	Write AC characteristics, Write Enable Controlled	68
Table 28.	Write AC characteristics, Chip Enable Controlled	71
Table 29.	Reset AC characteristics	72
Table 30.	Accelerated Program and Data Polling/Data Toggle AC characteristics	74
Table 31.	TSOP56 – 56 lead plastic thin small outline, 14 x 20 mm, package mechanical data	75
Table 32.	TBGA64 10 x 13 mm - 8 x 8 active ball array, 1 mm pitch, package mechanical data	76
Table 33.	Ordering information scheme	77
Table 34.	Block addresses	78
Table 35.	Query structure overview	82
Table 36.	CFI query identification string	82
Table 37.	CFI query system interface information	83
Table 38.	Device geometry definition	84
Table 39.	Primary algorithm-specific extended query table	85
Table 40.	Security code area	86
Table 41.	Extended memory block address and data	88
Table 42.	Document revision history	93

List of figures

Figure 1.	Logic diagram	9
Figure 2.	TSOP connections	10
Figure 3.	TBGA connections (top view through package)	11
Figure 4.	Block addresses	12
Figure 5.	Software protection scheme	26
Figure 6.	NVPB Program/Erase algorithm	45
Figure 7.	Lock Register program flowchart	53
Figure 8.	Data polling flowchart	57
Figure 9.	Toggle flowchart	58
Figure 10.	AC measurement load circuit	60
Figure 11.	AC measurement I/O waveform	61
Figure 12.	Power-up waiting timings	61
Figure 13.	Random Read AC waveforms (8-bit mode)	63
Figure 14.	Random Read AC waveforms (16-bit mode)	63
Figure 15.	Page Read AC waveforms (16-bit mode)	64
Figure 16.	Write Enable Controlled Program waveforms (8-bit mode)	66
Figure 17.	Write Enable Controlled Program waveforms (16-bit mode)	67
Figure 18.	Chip Enable Controlled Program waveforms (8-bit mode)	69
Figure 19.	Chip Enable Controlled Program waveforms (16-bit mode)	70
Figure 20.	Chip/Block Erase waveforms (8-bit mode)	71
Figure 21.	Reset AC waveforms (no program/erase ongoing)	72
Figure 22.	Reset during program/erase operation AC waveforms	72
Figure 23.	Accelerated program timing waveforms	73
Figure 24.	Data polling AC waveforms	73
Figure 25.	Toggle/Alternative Toggle bit polling AC waveforms (8-bit mode)	74
Figure 26.	TSOP56 – 56 lead plastic thin small outline, 14 x 20 mm, package outline	75
Figure 27.	TBGA64 10 x 13 mm - 8 x 8 active ball array, 1 mm pitch, package outline	76
Figure 28.	Write to Buffer Program flowchart and pseudocode	89
Figure 29.	Enhanced Buffered Program flowchart and pseudocode	91

1 Description

The M29W128GH and M29W128GL are 128 Mbit (8 Mb x 16 or 16 Mb x 8) non-volatile Flash memories that can be read, erased and reprogrammed. These operations can be performed using a single low voltage (2.7 to 3.6 V) supply. On power-up the memory defaults to its Read mode.

The memory array is divided into 64-Kword/128-Kbyte uniform blocks that can be erased independently so it is possible to preserve valid data while old data is erased. Program and Erase commands are written to the command interface of the memory. An on-chip Program/Erase controller simplifies the process of programming or erasing the memory by taking care of all of the special operations that are required to update the memory contents. The end of a program or erase operation can be detected and any error conditions identified. The command set required to control the memory is consistent with JEDEC standards.

Chip Enable, Output Enable and Write Enable signals control the bus operation of the memory. They allow simple connection to most microprocessors, often without additional logic.

The M29W128GH and M29W128GL support Asynchronous Random Read and Page Read from all blocks of the memory array. The devices also feature a Write to Buffer Program capability that improves the programming throughput by programming in one shot a buffer of 32 words/64 bytes. The Enhanced Buffered Program feature is also available to speed up the programming throughput, allowing to program 256 words in one shot (only in x 16 mode). The V_{PP}/\overline{WP} signal can be used to enable faster programming of the device.

The M29W128GH and M29W128GL have an extra block, the extended block, of 128 words in x 16 mode or of 256 bytes in x 8 mode that can be accessed using a dedicated command. The extended block can be protected and so is useful for storing security information. However the protection is not reversible, once protected the protection cannot be undone.

The device features different levels of hardware and software block protection to avoid unwanted program or erase (modify):

- Hardware protection:
 - The V_{PP}/\overline{WP} provides a hardware protection of the highest and lowest block on the M29W128GH, M29W128GL, respectively.
- Software protection:
 - Volatile protection
 - Non-volatile protection
 - Password protection

The M29W128GH and M29W128GL are offered in TSOP56 (14 x 20 mm), and TBGA64 (10 x 13 mm, 1 mm pitch), packages. The memories are delivered with all the bits erased (set to '1').

Table 2. Signal names

Name	Description	Direction
A0-A22	Address inputs	Inputs
DQ0-DQ7	Data inputs/outputs	I/O
DQ8-DQ14	Data inputs/outputs	I/O
DQ15A-1	Data input/output or address input	I/O
\bar{E}	Chip Enable	Input
\bar{G}	Output Enable	Input
\bar{W}	Write Enable	Input
\bar{RP}	Reset	Input
\bar{RB}	Ready/Busy output	Output
$\overline{\text{BYTE}}$	Byte/word organization select	Input
V _{CCQ}	Input/output buffer supply voltage	Supply
V _{CC}	Supply voltage	Supply
V _{PP} / $\overline{\text{WP}}$ ⁽¹⁾	V _{PP} /Write Protect	Input
V _{SS}	Ground	-
NC	Not connected	-

1. V_{PP}/ $\overline{\text{WP}}$ may be left floating as it is internally connected to a pull-up resistor which enables Program/Erase operations.

Figure 1. Logic diagram

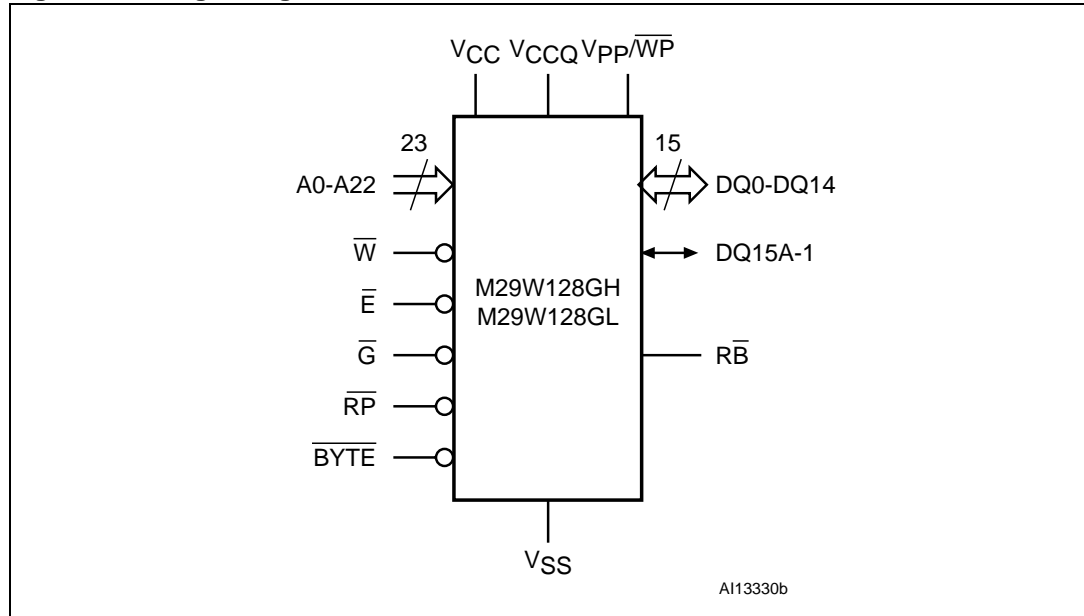

1. Also see [Appendix A](#) and [Table 34](#) for a full listing of the block addresses.

Figure 2. TSOP connections

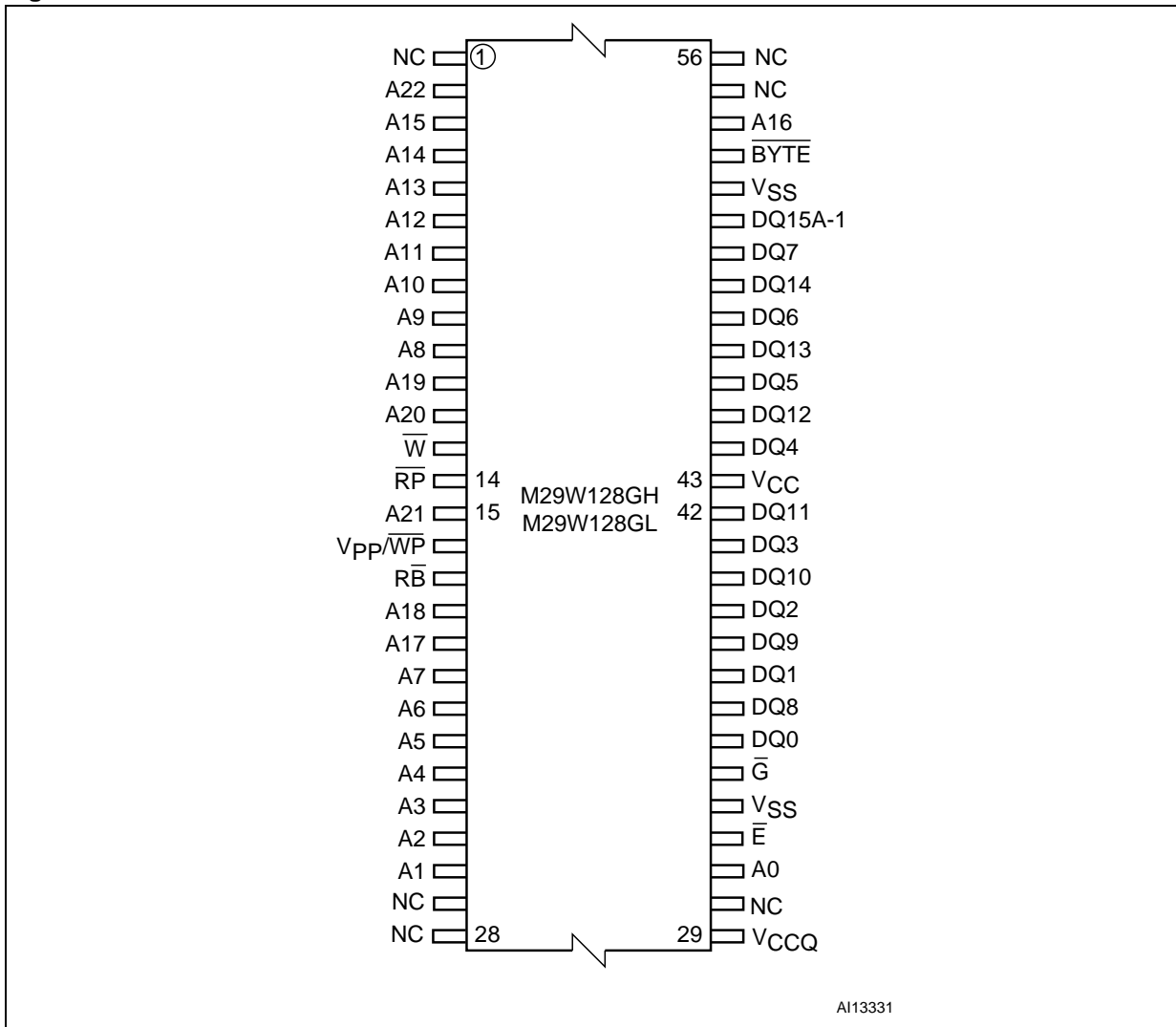

Figure 3. TBGA connections (top view through package)

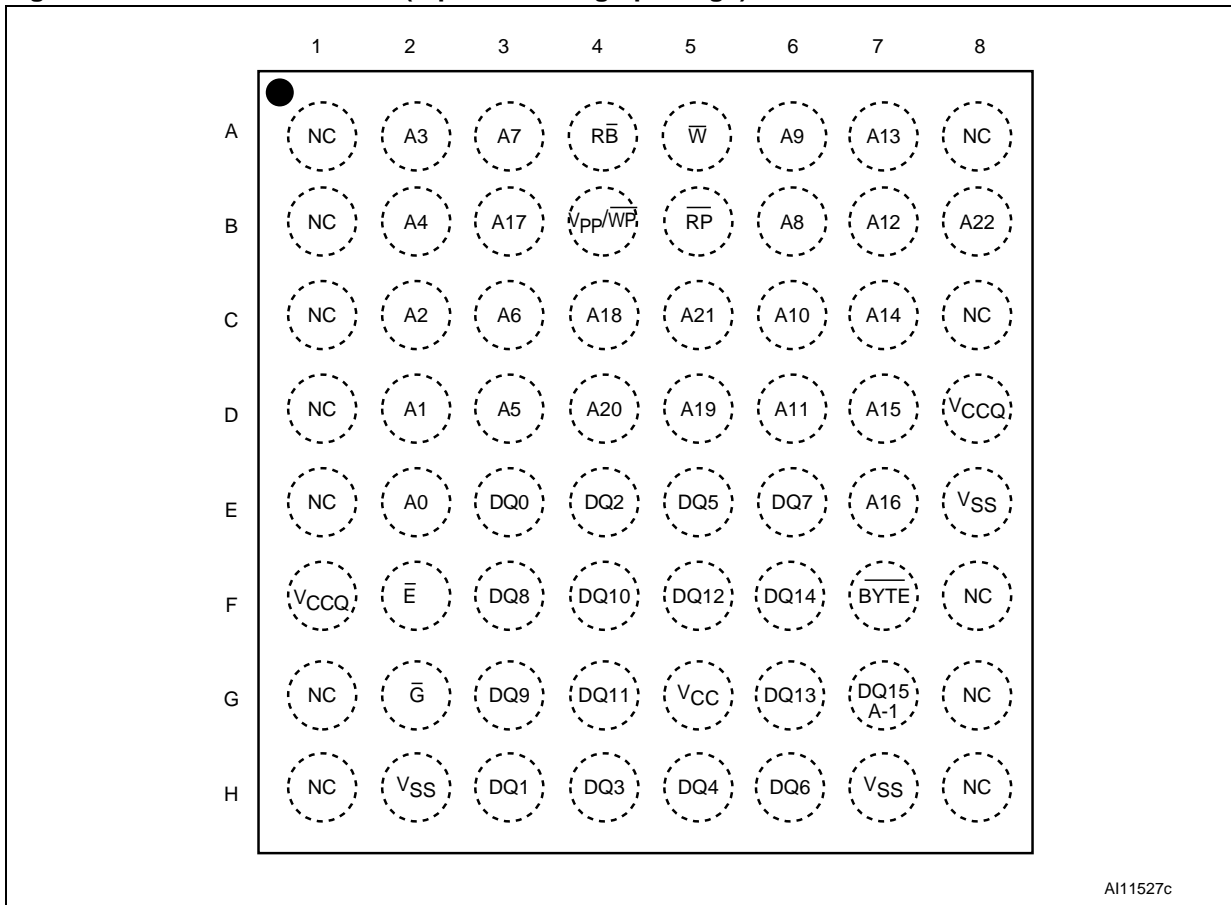
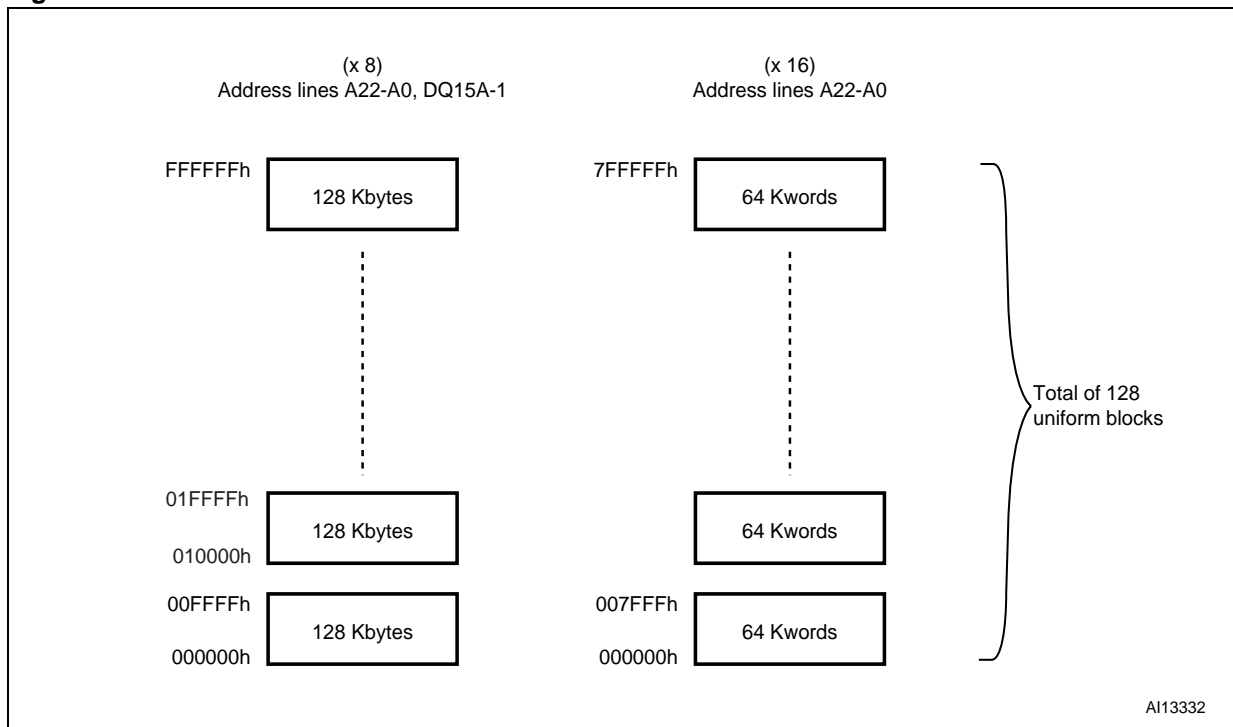

Figure 4. Block addresses



2 Signal descriptions

See [Figure 1: Logic diagram](#), and [Table 2: Signal names](#), for a brief overview of the signals connected to this device.

2.1 Address inputs (A0-A22)

The Address inputs select the cells in the memory array to access during Bus Read operations. During Bus Write operations they control the commands sent to the command interface of the Program/Erase controller.

2.2 Data inputs/outputs (DQ0-DQ7)

The Data I/O outputs the data stored at the selected address during a Bus Read operation. During Bus Write operations they represent the commands sent to the command interface of the internal state machine.

2.3 Data inputs/outputs (DQ8-DQ14)

The Data I/O outputs the data stored at the selected address during a Bus Read operation when $\overline{\text{BYTE}}$ is High, V_{IH} . When $\overline{\text{BYTE}}$ is Low, V_{IL} , these pins are not used and are high impedance. During Bus Write operations the Command Register does not use these bits. When reading the Status Register these bits should be ignored.

2.4 Data inputs/outputs or address inputs (DQ15A-1)

When the device is in x 16 bus mode, this pin behaves as a Data input/output pin (as DQ8-DQ14). When the device operates in x 8 bus mode, this pin behaves as the least significant bit of the address. Throughout the text consider references to the Data input/output to include this pin when the device operates in x 16 bus mode and references to the Address inputs to include this pin when the device operates in x 8 bus mode except when stated explicitly otherwise.

2.5 Chip Enable ($\overline{\text{E}}$)

The Chip Enable pin, $\overline{\text{E}}$, activates the memory, allowing Bus Read and Bus Write operations to be performed. When Chip Enable is High, V_{IH} , all other pins are ignored.

2.6 Output Enable ($\overline{\text{G}}$)

The Output Enable pin, $\overline{\text{G}}$, controls the Bus Read operation of the memory.

2.7 Write Enable (\overline{W})

The Write Enable pin, \overline{W} , controls the Bus Write operation of the memory's command interface.

2.8 $V_{PP}/\text{Write Protect}$ (V_{PP}/\overline{WP})

The $V_{PP}/\text{Write Protect}$ pin provides two functions. The V_{PPH} function allows the memory to use an external high voltage power supply to reduce the time required for program operations. This is achieved by bypassing the unlock cycles.

The Write Protect function provides a hardware method of protecting the highest or lowest block (see [Section 1: Description](#)). When $V_{PP}/\text{Write Protect}$ is Low, V_{IL} , the highest or lowest block is protected. Program and Erase operations on this block are ignored while $V_{PP}/\text{Write Protect}$ is Low.

When $V_{PP}/\text{Write Protect}$ is High, V_{IH} , the memory reverts to the previous protection status of the highest or lowest block. Program and Erase operations can now modify the data in this block unless the block is protected using Block protection.

When $V_{PP}/\text{Write Protect}$ is raised to V_{PPH} the memory automatically enters the Unlock Bypass mode (see [Section 6.2.6](#)).

When $V_{PP}/\text{Write Protect}$ is raised to V_{PPH} , the execution time of the command is lower (see [Table 17: Program, Erase times and Program, Erase endurance cycles](#)).

When $V_{PP}/\text{Write Protect}$ returns to V_{IH} or V_{IL} normal operation resumes. During Unlock Bypass Program operations the memory draws I_{PP} from the pin to supply the programming circuits. See the description of the Unlock Bypass command in the command interface section. The transitions from V_{IH} to V_{PPH} and from V_{PPH} to V_{IH} must be slower than t_{VHVPP} (see [Figure 23: Accelerated program timing waveforms](#)).

Never raise $V_{PP}/\text{Write Protect}$ to V_{PPH} from any mode except Read mode, otherwise the memory may be left in an indeterminate state. A 0.1 μF capacitor should be connected between the $V_{PP}/\text{Write Protect}$ pin and the V_{SS} ground pin to decouple the current surges from the power supply. The PCB track widths must be sufficient to carry the currents required during Unlock Bypass Program (see I_{PP1} , I_{PP2} , I_{PP3} , I_{PP4} in [Table 25: DC characteristics](#)).

The $V_{PP}/\text{Write Protect}$ pin may be left floating or unconnected because it features an internal pull-up.

Refer to [Table 3](#) for a summary of V_{PP}/\overline{WP} functions.

Table 3. V_{PP}/\overline{WP} functions

V_{PP}/\overline{WP}	Function
V_{IL}	Highest block protected on M29W128GH. Lowest block protected on M29W128GL.
V_{IH}	Highest and lowest block unprotected unless a software protection is activated (see Section 4: Hardware protection).
V_{PPH}	Unlock bypass mode. It supplies the current needed to speed up programming.

2.9 Reset ($\overline{\text{RP}}$)

The Reset pin can be used to apply a Hardware Reset to the memory.

A Hardware Reset is achieved by holding Reset Low, V_{IL} , for at least t_{PLPX} . After Reset goes High, V_{IH} , the memory will be ready for Bus Read and Bus Write operations after t_{PHEL} or t_{RHEL} , whichever occurs last. See [Section 2.10: Ready/Busy output \(RB\)](#), [Table 29: Reset AC characteristics](#), [Figure 21](#) and [Figure 22](#) for more details.

2.10 Ready/Busy output ($\overline{\text{RB}}$)

The Ready/Busy pin is an open-drain output that can be used to identify when the device is performing a program or erase operation. During program or erase operations Ready/Busy is Low, V_{OL} (see [Table 20: Status Register bits](#)). Ready/Busy is high-impedance during Read mode, Auto Select mode and Erase Suspend mode.

After a Hardware Reset, Bus Read and Bus Write operations cannot begin until Ready/Busy becomes high-impedance. See [Table 29: Reset AC characteristics](#), [Figure 21](#) and [Figure 22](#).

The use of an open-drain output allows the Ready/Busy pins from several memories to be connected to a single pull-up resistor. A Low will then indicate that one, or more, of the memories is busy.

2.11 Byte/word organization select ($\overline{\text{BYTE}}$)

It is used to switch between the x 8 and x 16 Bus modes of the memory. When Byte/word organization select is Low, V_{IL} , the memory is in x 8 mode, when it is High, V_{IH} , the memory is in x 16 mode.

2.12 V_{CC} supply voltage

V_{CC} provides the power supply for all operations (Read, Program and Erase).

The command interface is disabled when the V_{CC} supply voltage is less than the Lockout voltage, V_{LKO} . This prevents Bus Write operations from accidentally damaging the data during power-up, power-down and power surges. If the Program/Erase controller is programming or erasing during this time then the operation aborts and the memory contents being altered will be invalid.

A 0.1 μF capacitor should be connected between the V_{CC} supply voltage pin and the V_{SS} ground pin to decouple the current surges from the power supply. The PCB track widths must be sufficient to carry the currents required during program and erase operations (see I_{CC1} , I_{CC2} , I_{CC3} in [Table 25: DC characteristics](#)).

2.13 V_{CCQ} input/output supply voltage

V_{CCQ} provides the power supply to the I/O pins and enables all outputs to be powered independently from V_{CC} .

2.14 V_{SS} ground

V_{SS} is the reference for all voltage measurements. The device features two V_{SS} pins both of which must be connected to the system ground.

3 Bus operations

There are five standard bus operations that control the device. These are Bus Read (Random and Page modes), Bus Write, Output Disable, Standby and Automatic Standby.

See [Table 4: Bus operations, 8-bit mode](#) and [Table 5: Bus operations, 16-bit mode](#) for a summary. Typical glitches of less than 5 ns on Chip Enable, Write Enable, and Reset pins are ignored by the memory and do not affect bus operations.

3.1 Bus Read

Bus Read operations read from the memory cells, or specific registers in the command interface. To speed up the read operation the memory array can be read in Page mode where data is internally read and stored in a page buffer. The page has a size of 8 words (or 16 bytes) and is addressed by the address inputs A2-A0 in x 16 mode and A2-A0 plus DQ15A-1 in byte mode.

A valid Bus Read operation involves setting the desired address on the Address inputs, applying a Low signal, V_{IL} , to Chip Enable and Output Enable and keeping Write Enable High, V_{IH} . The Data inputs/outputs will output the value, see [Figure 13: Random Read AC waveforms \(8-bit mode\)](#), [Figure 15: Page Read AC waveforms \(16-bit mode\)](#), and [Table 26: Read AC characteristics](#), for details of when the output becomes valid.

3.2 Bus Write

Bus Write operations write to the command interface. A valid Bus Write operation begins by setting the desired address on the Address inputs. The Address inputs are latched by the command interface on the falling edge of Chip Enable or Write Enable, whichever occurs last. The Data inputs/outputs are latched by the command interface on the rising edge of Chip Enable or Write Enable, whichever occurs first. Output Enable must remain High, V_{IH} , during the whole Bus Write operation. See [Figure 16](#), and [Figure 17](#), Write AC waveforms, and [Table 27](#) and [Table 28](#), Write AC characteristics, for details of the timing requirements.

3.3 Output Disable

The Data inputs/outputs are in the high impedance state when Output Enable is High, V_{IH} .

3.4 Standby

Driving Chip Enable High in Read mode, causes the memory to enter Standby mode and the data inputs/outputs pins are placed in the high-impedance state. To reduce the Supply current to the Standby Supply current, I_{CC2} , Chip Enable should be held within $V_{CC} \pm 0.3$ V. For the Standby current level see [Table 25: DC characteristics](#).

During program or erase operations the memory will continue to use the Program/Erase Supply current, I_{CC3} , for Program or Erase operations until the operation completes.

3.5 Reset

During Reset mode the memory is deselected and the outputs are high impedance. The memory is in Reset mode when \overline{RP} is at VIL. The power consumption is reduced to the standby level, independently from the Chip Enable, Output Enable or Write Enable inputs.

3.6 Automatic Standby

Automatic Standby allows the memory to achieve low power consumption during Read mode.

After a read operation, if CMOS levels ($V_{CC} \pm 0.3$ V) are used to drive the bus and the bus is inactive for $t_{AVQV} + 30$ ns or more, the memory enters Automatic Standby where the internal Supply current is reduced to the Standby Supply current, I_{CC2} (see [Table 25: DC characteristics](#)). The Data inputs/outputs will still output data if a Bus Read operation is in progress.

The power supplier of data bus, V_{CCQ} , can have a null consumption (depending on load circuits connected with data bus) when the memory enters Automatic Standby.

3.7 Auto Select mode

The Auto Select mode allows the system or the programming equipment to read the electronic signature, verify the protection status of the extended memory block, and apply/remove Block protection. For example, this mode can be used by a programming equipment to automatically match a device and the application code to be programmed.

There are two methods to enter Auto Select mode:

- programmer method:
Additional bus operations are used. They require V_{ID} to be applied to address pin A9. Refer to [Table 6](#), [Table 7](#), [Table 8](#), and [Table 9](#) for a description of the bus operations required to read the electronic signature using the programmer method
- in-system method:
The Auto Select mode is entered by issuing the Auto Select command (see [Section 6.1.2](#)). It is not necessary to apply V_{ID} to A9.

At power-up, the device is in Read mode, and can then be put in Auto Select mode by using one of the methods described above.

The device cannot enter Auto Select mode when a program or erase operation is ongoing (\overline{RB} Low). However, Auto Select mode can be entered if the erase operation has been suspended by issuing an Erase Suspend command (see [Section 6.1.6](#)).

The Auto Select mode is exited by performing a reset. The device is returned to Read mode, except if the Auto Select mode was entered after an Erase Suspend or a Program Suspend command. In this case, it returns to the Erase or Program Suspend mode.

3.7.1 Read electronic signature

The memory has two codes, the manufacturer code and the device code used to identify the memory. These codes can be accessed by performing read operations with control signals and addresses set as shown in [Table 6: Read electronic signature - auto select mode -](#)

programmer method (8-bit mode) and *Table 7: Read electronic signature - auto select mode - programmer method (16-bit mode)*.

These codes can also be accessed by issuing an Auto Select command (see *Section 6.1.2: Auto Select command*).

3.7.2 Verify extended memory block protection indicator

The extended memory block is either factory locked or customer lockable.

The protection status of the extended memory block (factory locked or customer lockable) can be accessed by reading the extended memory block protection indicator. It can be read in Auto Select mode using either the programmer (see *Table 8* and *Table 9*) or the in-system method (see *Table 10* and *Table 11*).

The protection status of the extended memory block is then output on bit DQ7 of the Data input/outputs (see *Table 4* and *Table 5*, Bus operations in 8-bit and 16-bit mode).

3.7.3 Verify block protection status

The protection status of a block can be directly accessed by performing a read operation with control signals and addresses set as shown in *Table 8* and *Table 9*.

If the block is protected, then 01h (in x 8 mode) is output on Data input/outputs DQ0-DQ7, otherwise 00h is output.

3.7.4 Hardware Block Protect

The $V_{PP}\overline{WP}$ pin can be used to protect the highest or lowest block. When $V_{PP}\overline{WP}$ is at V_{IL} the highest (M29W128GH) or lowest block (M29W128GL) is protected and remains protected regardless of the block protection status or the Reset pin state.

Table 4. Bus operations, 8-bit mode

Operation ⁽¹⁾	\bar{E}	\bar{G}	\bar{W}	$\bar{R}\bar{P}$	$V_{PP}/\bar{W}\bar{P}$	Address Inputs	Data inputs/outputs	
						A22-A0, DQ15A-1	DQ14-DQ8	DQ7-DQ0
Bus Read	V_{IL}	V_{IL}	V_{IH}	V_{IH}	X	Cell address	Hi-Z	Data output
Bus Write	V_{IL}	V_{IH}	V_{IL}	V_{IH}	$V_{IH}^{(2)}$	Command address	Hi-Z	Data input ⁽³⁾
Standby	V_{IH}	X	X	V_{IH}	V_{IH}	X	Hi-Z	Hi-Z
Output Disable	V_{IL}	V_{IH}	V_{IH}	V_{IH}	X	X	Hi-Z	Hi-Z
Reset	X	X	X	V_{IL}	X	X	Hi-Z	Hi-Z

1. X = V_{IL} or V_{IH} .

2. If $\bar{W}\bar{P}$ is Low, V_{IL} , the outermost block remains protected.

3. Data input as required when issuing a command sequence, performing data polling or block protection.

Table 5. Bus operations, 16-bit mode

Operation ⁽¹⁾	\bar{E}	\bar{G}	\bar{W}	$\bar{R}\bar{P}$	$V_{PP}/\bar{W}\bar{P}$	Address inputs	Data inputs/outputs
						A22-A0	DQ15A-1, DQ14-DQ0
Bus Read	V_{IL}	V_{IL}	V_{IH}	V_{IH}	X	Cell address	Data output
Bus Write	V_{IL}	V_{IH}	V_{IL}	V_{IH}	$V_{IH}^{(2)}$	Command address	Data input ⁽³⁾
Standby	V_{IH}	X	X	V_{IH}	V_{IH}	X	Hi-Z
Output Disable	V_{IL}	V_{IH}	V_{IH}	V_{IH}	X	X	Hi-Z
Reset	X	X	X	V_{IL}	X	X	Hi-Z

1. X = V_{IL} or V_{IH} .

2. If $\bar{W}\bar{P}$ is Low, V_{IL} , the outermost block remains protected.

3. Data input as required when issuing a command sequence, performing data polling or block protection.

Table 6. Read electronic signature - auto select mode - programmer method (8-bit mode)

Read cycle ⁽¹⁾	\bar{E}	\bar{G}	\bar{W}	Address inputs										Data inputs/outputs						
				A22-A10	A9	A8-A7	A6	A5-A4	A3	A2	A1	A0	DQ15A-1	DQ14-DQ8	DQ7-DQ0					
Manufacturer code	V _{IL}	V _{IL}	V _{IH}	X	V _{ID} ⁽²⁾	X	V _{IL}	X						V _{IL}	V _{IL}	V _{IL}	V _{IL}	X	X	20h
Device code (cycle 1)														V _{IL}	V _{IL}	V _{IL}	V _{IH}	X	X	7Eh (both devices)
Device code (cycle 2)														V _{IH}	V _{IH}	V _{IH}	V _{IL}	X	X	21h (both devices)
Device code (cycle 3)														V _{IH}	V _{IH}	V _{IH}	V _{IH}	X	X	01h (M29W128GH) 00h (M29W128GL)

1. X = V_{IL} or V_{IH}.
2. When using the in-system method, applying V_{ID} to A9 is not required. A9 can be either V_{IL} or V_{IH}.

Table 7. Read electronic signature - auto select mode - programmer method (16-bit mode)

Read cycle ⁽¹⁾	\bar{E}	\bar{G}	\bar{W}	Address inputs										Data inputs/outputs						
				A22-A10	A9	A8-A7	A6	A5-A4	A3	A2	A1	A0	DQ15A-1, DQ14-DQ0							
Manufacturer code	V _{IL}	V _{IL}	V _{IH}	X	V _{ID} ⁽²⁾	X	V _{IL}	X								V _{IL}	V _{IL}	V _{IL}	V _{IL}	0020h
Device code (cycle 1)																V _{IL}	V _{IL}	V _{IL}	V _{IH}	227Eh (both devices)
Device code (cycle 2)																V _{IH}	V _{IH}	V _{IH}	V _{IL}	2221h (both devices)
Device code (cycle 3)																V _{IH}	V _{IH}	V _{IH}	V _{IH}	2201h (M29W128GH) 2200h (M29W128GL)

1. X = V_{IL} or V_{IH}.
2. When using the in-system method, applying V_{ID} to A9 is not required. A9 can be either V_{IL} or V_{IH}.

Table 8. Block protection - auto select mode - programmer method (8-bit mode)

Operation ⁽¹⁾		\bar{E}	\bar{G}	\bar{W}	Address inputs								Data inputs/outputs			
					A22-A16	A14-A10	A9	A8-A7	A6	A5-A4	A3-A2	A1	A0	DQ15-A-1	DQ14-DQ8	DQ7-DQ0
Verify extended memory block protection indicator (bit DQ7)	M29W128GL	V_{IL}	V_{IL}	V_{IH}	X											89h (factory locked) 09h (customer lockable)
	M29W128GH					X	$V_{ID}^{(2)}$	X	V_{IL}	X	V_{IL}	V_{IH}	V_{IH}	X	X	99h (factory locked) 19h (customer lockable)
Verify block protection status					BAd									V_{IL}		01h (protected) 00h (unprotected)

1. X = V_{IL} or V_{IH} . BAd any address in the block.
2. When using the in-system method, applying V_{ID} to A9 is not required. A9 can be either V_{IL} or V_{IH} .

Table 9. Block protection - auto select mode - programmer method (16-bit mode)

Operation ⁽¹⁾		\bar{E}	\bar{G}	\bar{W}	Address inputs								Data inputs/outputs		
					A22-A16	A14-A10	A9	A8-A7	A6	A5-A4	A3-A2	A1	A0	DQ15A-1, DQ14-DQ0	
Verify extended memory block indicator (bit DQ7)	M29W128GL	V_{IL}	V_{IL}	V_{IH}	X										0089h (factory locked) 0009h (customer lockable)
	M29W128GH					X	$V_{ID}^{(2)}$	X	V_{IL}	X	V_{IL}	V_{IH}	V_{IH}	0099h (factory locked) 0019h (customer lockable)	
Verify block protection status					BAd									V_{IL}	0001h (protected) 0000h (unprotected)

1. X = V_{IL} or V_{IH} . BAd any address in the block.
2. When using the in-system method, applying V_{ID} to A9 is not required. A9 can be either V_{IL} or V_{IH} .

4 Hardware protection

The M29W128GH and M29W128GL feature a V_{PP}/\overline{WP} pin that protects the highest or lowest block. Refer to [Section 2: Signal descriptions](#) for a detailed description of the signal.

5 Software protection

The M29W128GH and M29W128GL have three different software protection modes:

- Volatile protection
- Non-volatile protection
- Password protection

On first use all parts default to operate in non-volatile protection mode and the customer is free to activate the non-volatile or the password protection mode.

The desired protection mode is activated by setting either the one-time programmable Non-volatile Protection Mode Lock bit, or the Password Protection Mode Lock bit of the Lock Register (see [Section 7.1: Lock Register](#)). Programming the Non-volatile Protection Mode Lock bit or the Password Protection Mode Lock bit, to '0' will permanently activate the Non-volatile or the Password Protection mode, respectively. These two bits are one-time programmable and non-volatile: once the protection mode has been programmed, it cannot be changed and the device will permanently operate in the selected protection mode. It is recommended to activate the desired software protection mode when first programming the device.

The Non-volatile and Password Protection modes both provide non-volatile protection. Volatilely protected blocks and non-volatilely protected blocks can co-exist within the memory array. However, the volatile protection only control the protection scheme for blocks that are not protected using the non-volatile or password protection.

If the user attempts to program or erase a protected block, the device ignores the command and returns to read mode.

The device is shipped with all blocks unprotected. The block protection status can be read either by performing a read electronic signature (see [Table 6](#) and [Table 7](#)) or by issuing an Auto Select command (see [Table 19: Block protection status](#)).

For the lowest and highest blocks, an even higher level of block protection can be achieved by locking the blocks using the non-volatile protection and then by holding the V_{PP}/\overline{WP} pin Low.

5.1 Volatile protection mode

The volatile protection allows the software application to easily protect blocks against inadvertent change. However, the protection can be easily disabled when changes are needed. Volatile Protection bits, VPBs, are volatile and unique for each block and can be individually modified. VPBs only control the protection scheme for unprotected blocks that have their non-volatile protection bits, NVPBs, cleared (erased to '1') (see [Section 5.2: Non-volatile protection mode](#) and [Section 6.3.5: Non-volatile Protection mode command set](#)).

By issuing the VPB Program or VPB Clear commands, the VPBs are set (programmed to '0') or cleared (erased to '1'), thus placing each block in the protected or unprotected state respectively. The VPBs can be set (programmed to '0') or cleared (erased to '1') as often as needed.

When the parts are first shipped, or after a power-up or hardware reset, the VPBs can be set or cleared depending upon the ordering option chosen:

- If the option to clear the VPBs after power-up is selected, then the blocks can be programmed or erased depending on the NVPBs state (see [Table 19: Block protection status](#))
- If the option to set the VPBs after power-up is selected, the blocks default to be protected.

Refer to [Section 6.3.7](#) for a description of the volatile protection mode command set.

5.2 Non-volatile protection mode

5.2.1 Non-volatile protection bits

A non-volatile protection bit (NVPB) is assigned to each block.

When a NVPB is set to '0', the associated block is protected, preventing any program or erase operations in this block.

The NVPB bits are set individually by issuing a NVPB Program command. They are non-volatile and will remain set through a hardware reset or a power-down/power-up sequence.

The NVPBs cannot be cleared individually, they can only be cleared all at the same time by issuing a Clear all Non-volatile Protection bits command.

The NVPBs can be protected all at a time by setting a volatile bit, the NVPB Lock bit (see [Section 5.2.2: Non-volatile Protection Bit Lock bit](#)).

If one of the non-volatile protected blocks needs to be unprotected (corresponding NVPB set to '1'), a few more steps are required:

1. First, the NVPB Lock bit must be cleared by either putting the device through a power cycle, or hardware reset
2. The NVPBs can then be changed to reflect the desired settings
3. The NVPB Lock bit must be set once again to lock the NVPBs. The device operates normally again.

- Note:*
- 1 To achieve the best protection, it is recommended to execute the NVPB Lock Bit Program command early in the boot code and to protect the boot code by holding V_{PP}/\overline{WP} Low, V_{IL} .
 - 2 The NVPBs and VPBs have the same function when V_{PP}/\overline{WP} pin is High, V_{IH} , as they do when V_{PP}/\overline{WP} pin is at the voltage for program acceleration (V_{PPH}).

Refer to [Table 19: Block protection status](#) and [Figure 5: Software protection scheme](#) for details on the block protection mechanism, and to [Section 6.3.5](#) for a description of the Non-volatile Protection mode command set.

5.2.2 Non-volatile Protection Bit Lock bit

The Non-volatile Protection Bit Lock bit (NVPB Lock bit) is a global volatile bit for all blocks.

When set (programmed to '0'), it prevents changing the state of the NVPBs. When cleared (programmed to '1'), the NVPBs can be set and reset using the NVPB Program command and Clear all NVPBs command, respectively.

There is only one NVPB Lock bit per device.

Refer to [Section 6.3.6](#) for a description of the NVPB Lock bit command set.

- Note:*
- 1 *No software command unlocks this bit unless the device is in password protection mode; it can be cleared only by taking the device through a hardware reset or a power-up.*
 - 2 *The NVPB Lock bit must be set (programmed to '0') only after all NVPBs are configured to the desired settings.*

5.3 Password protection mode

The password protection mode provides an even higher level of security than the Non-volatile Protection mode by requiring a 64-bit password for unlocking the device NVPB Lock bit.

In addition to this password requirement, the NVPB Lock bit is set '0' after power-up and reset to maintain the device in password protection mode. Successful execution of the Password Unlock command by entering the correct password clears the NVPB Lock bit, allowing for block NVPBs to be modified.

If the password provided is not correct, the NVPL Lock bit remains locked and the state of the NVPBs cannot be modified.

To place the device in password protection mode, the following steps are required:

1. Prior to entering the password protection mode, it is necessary to set a 64-bit password and to verify it (see [Password Program command](#) and [Password Read command](#)). Password verification is only allowed during the password programming operation
2. The password protection mode is then activated by programming the Password Protection Mode Lock bit to '0'. This operation is not reversible and once the bit is programmed it cannot be erased, the device permanently remains in password protection mode, and the 64-bit password can neither be retrieved nor reprogrammed. Moreover, all commands to the address where the password is stored, are disabled. Refer to [Table 19: Block protection status](#) and [Figure 5: Software protection scheme](#) for details on the block protection scheme.

Refer to [Section 6.3.4](#) for a description of the Password Protection mode command set.

- Note:*
- There is no means to verify the password after it is set. If the password is lost after setting the Password Mode Lock bit, there is no way to clear the NVPB Lock bit.*

Figure 5. Software protection scheme

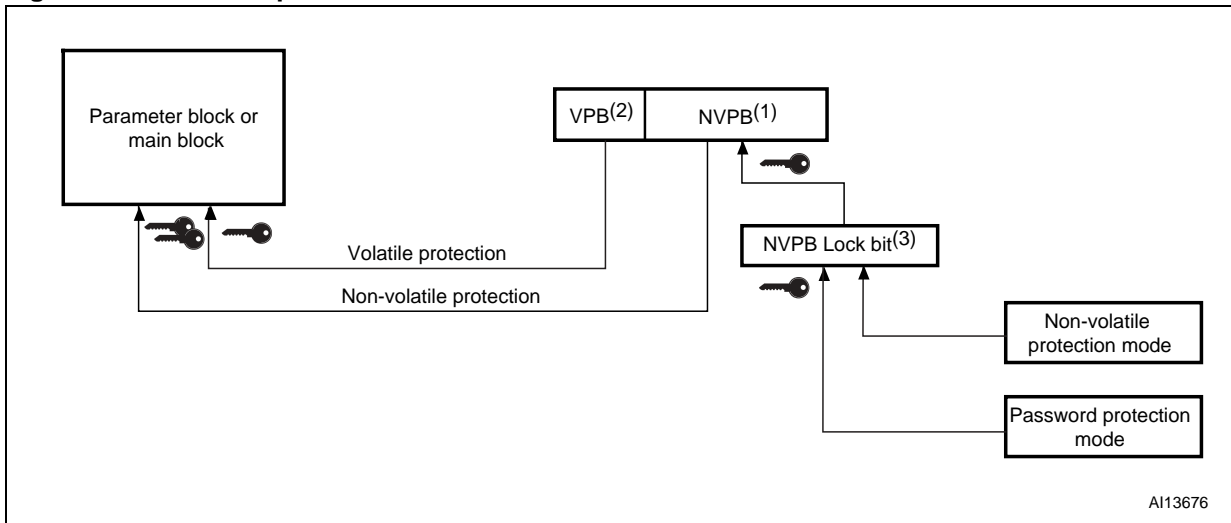

1. NVPBs default to '1' (block unprotected) after power-up and hardware reset. A block is protected or unprotected when its NVPB is set to '0' and '1', respectively. NVPBs are programmed individually and cleared collectively.
2. VPB default status depends on ordering option. A block is protected or unprotected when its VPB is set to '0' and '1', respectively. VPBs are programmed and cleared individually. For the volatile protection to be effective, the NVPB Lock bit must be set to '0' (NVPB bits unlocked) and the block NVPB must be set to '1' (block unprotected).
3. The NVPB Lock bit is volatile and default to '1' (NVPB bits unlocked) after power-up and hardware reset. NVPB bits are locked by setting the NVPB Lock bit to '0'. Once programmed to '0', the NVPB Lock bit can be reset to '1' only by taking the device through a power-up or hardware reset.

6 Command interface

All Bus Write operations to the memory are interpreted by the command interface. Commands consist of one or more sequential Bus Write operations. Failure to observe a valid sequence of Bus Write operations will result in the memory returning to Read mode. The long command sequences are imposed to maximize data security.

The address used for the commands changes depending on whether the memory is in 16-bit or 8-bit mode.

6.1 Standard commands

See either [Table 10](#), or [Table 11](#), depending on the configuration that is being used, for a summary of the standard commands.

6.1.1 Read/Reset command

The device is in Read mode after reset or after power-up.

The Read/Reset command returns the memory to Read mode. It also resets the errors in the Status Register. Either one or three Bus Write operations can be used to issue the Read/Reset command.

The Read/Reset command can be issued, between Bus Write cycles before the start of a program or erase operation, to return the device to Read mode. If the Read/Reset command is issued during the timeout of a Block erase operation, the memory will take up to 10 μ s to abort. During the abort period no valid data can be read from the memory.

The Read/Reset command will not abort an Erase operation when issued while in Erase Suspend.

6.1.2 Auto Select command

The Auto Select command puts the device in Auto Select mode, when using the in-system method (see [Section 3.7: Auto Select mode](#)). When in Auto Select mode, the system can read the manufacturer code, the device code, the protection status of each block (Block Protection status) and the extended memory block protection indicator.

Three consecutive Bus Write operations are required to issue the Auto Select command. Once the Auto Select command is issued Bus Read operations to specific addresses output the manufacturer code, the device code, the extended memory block protection indicator and a block protection status (see [Table 10](#) and [Table 11](#) in conjunction with [Table 6](#), [Table 7](#), [Table 8](#), and [Table 9](#)). The memory remains in Auto Select mode until a Read/Reset or CFI Query command is issued.

6.1.3 Read CFI Query command

The memory contains an information area, named CFI data structure, which contains a description of various electrical and timing parameters, density information and functions supported by the memory. See [Appendix B](#), [Table 35](#), [Table 36](#), [Table 37](#), [Table 38](#), [Table 39](#) and [Table 40](#) for details on the information contained in the common Flash interface (CFI) memory area.

The Read CFI Query command is used to put the memory in Read CFI Query mode. Once in Read CFI Query mode, Bus Read operations to the memory will output data from the common Flash interface (CFI) memory area. One Bus Write cycle is required to issue the Read CFI Query command. This command is valid only when the device is in the Read Array or Auto Select mode.

The Read/Reset command must be issued to return the device to the previous mode (the Read Array mode or Auto Select mode). A second Read/Reset command is required to put the device in Read Array mode from Auto Select mode.

6.1.4 Chip Erase command

The Chip Erase command can be used to erase the entire chip. Six Bus Write operations are required to issue the Chip Erase command and start the Program/Erase controller.

If some blocks are protected, then these are ignored and all the other blocks are erased. If all of the blocks are protected the Chip Erase operation appears to start but will terminate within about 100 μ s, leaving the data unchanged. No error condition is given when protected blocks are ignored.

During the Erase operation the memory will ignore all commands, including the Erase Suspend command. It is not possible to issue any command to abort the operation. Typical Chip Erase times are given in [Table 17](#). All Bus Read operations during the Chip Erase operation will output the Status Register on the Data inputs/outputs. See [Section 7.2: Status Register](#) for more details.

After the Chip Erase operation has completed the memory will return to the Read mode, unless an error has occurred. When an error occurs the memory will continue to output the Status Register. A Read/Reset command must be issued to reset the error condition and return to Read mode.

The Chip Erase command sets all of the bits in unprotected blocks of the memory to '1'. All previous data is lost.

The Chip Erase operation is aborted by performing a reset or powering down the device. In this case, data integrity cannot be ensured, and it is recommended to erase again the entire chip.

6.1.5 Block Erase command

The Block Erase command can be used to erase a list of one or more blocks. It sets all of the bits in the unprotected selected blocks to '1'. All previous data in the selected blocks is lost.

Six Bus Write operations are required to select the first block in the list. Each additional block in the list can be selected by repeating the sixth Bus Write operation using the address of the additional block. After the command sequence is written, a Block Erase timeout occurs. During the timeout period, additional sector addresses and sector erase commands may be written. Once the Program/Erase controller has started, it is not possible to select

any more blocks. Each additional block must therefore be selected within the timeout period of the last block. The timeout timer restarts when an additional block is selected. After the sixth Bus Write operation, a Bus Read operation outputs the Status Register. See [Figure 16: Write Enable Controlled Program waveforms \(8-bit mode\)](#) and [Figure 17: Write Enable Controlled Program waveforms \(16-bit mode\)](#) for details on how to identify if the Program/Erase controller has started the Block Erase operation.

After the Block Erase operation has completed, the memory returns to the Read mode, unless an error has occurred. When an error occurs, Bus Read operations will continue to output the Status Register. A Read/Reset command must be issued to reset the error condition and return to Read mode.

If any selected blocks are protected then these are ignored and all the other selected blocks are erased. If all of the selected blocks are protected the Block Erase operation appears to start but will terminate within about 100 μ s, leaving the data unchanged. No error condition is given when protected blocks are ignored.

During the Block Erase operation the memory ignores all commands except the Erase Suspend command and the Read/Reset command which is only accepted during the timeout period. Typical Block Erase time and Block Erase timeout are given in [Table 17](#).

The Block Erase operation is aborted by performing a reset or powering down the device. In this case, data integrity cannot be ensured, and it is recommended to erase again the blocks aborted.

6.1.6 Erase Suspend command

The Erase Suspend command can be used to temporarily suspend a Block Erase operation. One Bus Write operation is required to issue the command together with the block address.

After the command sequence is written, a minimum Block Erase timeout occurs (see [Section 6.1.6: Erase Suspend command](#)). During the timeout period, additional block addresses and block erase commands can be written.

The Program/Erase controller suspends the erase operation within the Erase Suspend Latency time of the Erase Suspend command being issued. However, when the Erase Suspend command is written during the Block Erase timeout, the device immediately terminates the timeout period and suspends the erase operation.

Once the Program/Erase controller has stopped, the memory operates in Read mode and the Erase is suspended.

During Erase Suspend it is possible to read and execute Program or Write to Buffer Program operations in blocks that are not suspended; both read and program operations behave as normal on these blocks. Reading from blocks that are suspended will output the Status Register. If any attempt is made to program in a protected block or in the suspended block then the Program command is ignored and the data remains unchanged. In this case the Status Register is not read and no error condition is given.

It is also possible to issue the Auto Select, Read CFI Query and Unlock Bypass commands during an Erase Suspend. The Read/Reset command must be issued to return the device to Read Array mode before the Resume command will be accepted.

During Erase Suspend a Bus Read operation to the extended memory block will output the extended memory block data. Once in the Extended Block mode, the Exit Extended Block command must be issued before the erase operation can be resumed.

The Erase Suspend command is ignored if written during Chip Erase operations.

Refer to [Table 17: Program, Erase times and Program, Erase endurance cycles](#) for the values of Block Erase timeout and Block Erase Suspend latency time.

If the Erase Suspend operation is aborted by performing a reset or powering down the device, data integrity cannot be ensured, and it is recommended to erase again the blocks suspended.

6.1.7 Erase Resume command

The Erase Resume command is used to restart the Program/Erase controller after an Erase Suspend.

The device must be in Read Array mode before the Resume command will be accepted. An erase can be suspended and resumed more than once.

6.1.8 Program Suspend command

The Program Suspend command allows the system to interrupt a program operation so that data can be read from any block. When the Program Suspend command is issued during a program operation, the device suspends the program operation within the Program Suspend latency time (see [Table 17: Program, Erase times and Program, Erase endurance cycles](#)) and updates the Status Register bits.

After the program operation has been suspended, the system can read array data from any address. However, data read from program-suspended addresses is not valid.

The Program Suspend command may also be issued during a program operation while an erase is suspended. In this case, data may be read from any addresses not in Erase Suspend or Program Suspend. If a read is needed from the extended memory block area (one-time program area), the user must use the proper command sequences to enter and exit this region.

The system may also issue the Auto Select command sequence when the device is in the Program Suspend mode. The system can read as many Auto Select codes as required. When the device exits the Auto Select mode, the device reverts to the Program Suspend mode, and is ready for another valid operation. See Auto Select command sequence for more information.

If the Program Suspend operation is aborted by performing a reset or powering down the device, data integrity cannot be ensured, and it is recommended to program again the words or bytes aborted.

6.1.9 Program Resume command

After the Program Resume command is issued, the device reverts to programming. The controller can determine the status of the program operation using the DQ7 or DQ6 status bits, just as in the standard program operation. Refer to [Figure 16: Write Enable Controlled Program waveforms \(8-bit mode\)](#) and [Figure 17: Write Enable Controlled Program waveforms \(16-bit mode\)](#) for details.

The system must issue a Program Resume command, to exit the Program Suspend mode and to continue the programming operation.

Further issuing of the Resume command is ignored. Another Program Suspend command can be written after the device has resumed programming.

6.1.10 Program command

The Program command can be used to program a value to one address in the memory array at a time. The command requires four Bus Write operations, the final write operation latches the address and data in the internal state machine and starts the Program/Erase controller.

Programming can be suspended and then resumed by issuing a Program Suspend command and a Program Resume command, respectively (see [Section 6.1.8: Program Suspend command](#) and [Section 6.1.9: Program Resume command](#)).

If the address falls in a protected block then the Program command is ignored, the data remains unchanged. The Status Register is never read and no error condition is given.

After programming has started, Bus Read operations output the Status Register content. See [Figure 16: Write Enable Controlled Program waveforms \(8-bit mode\)](#) and [Figure 17: Write Enable Controlled Program waveforms \(16-bit mode\)](#) for more details. Typical program times are given in [Table 17: Program, Erase times and Program, Erase endurance cycles](#).

After the program operation has completed the memory will return to the Read mode, unless an error has occurred. When an error occurs, Bus Read operations to the memory continue to output the Status Register. A Read/Reset command must be issued to reset the error condition and return to Read mode.

One of the Erase commands must be used to set all the bits in a block or in the whole memory from '0' to '1'.

The Program operation is aborted by performing a reset or powering-down the device. In this case data integrity cannot be ensured, and it is recommended to reprogram the word or byte aborted.

Table 10. Standard commands, 8-bit mode

Command		Length	Bus operations ⁽¹⁾											
			1st		2nd		3rd		4th		5th		6th	
			Add	Data	Add	Data	Add	Data	Add	Data	Add	Data	Add	Data
Read/Reset		1	X	F0										
		3	AAA	AA	555	55	X	F0						
Auto Select	Manufacturer code	3	AAA	AA	555	55	AAA	90	(2)(3)	(2)(3)				
	Device code													
	Extended memory block protection indicator													
	Block protection status													
Program ⁽⁴⁾		4	AAA	AA	555	55	AAA	A0	PA	PD				
Chip Erase		6	AAA	AA	555	55	AAA	80	AAA	AA	555	55	AAA	10
Block Erase		6+	AAA	AA	555	55	AAA	80	AAA	AA	555	55	BAd	30
Erase/Program Suspend		1	X	B0										
Erase/Program Resume		1	X	30										
Read CFI Query		1	AA	98										

1. X Don't care, PA Program Address, PD Program Data, BAd Any address in the Block. All values in the table are in hexadecimal.
2. These cells represent Read cycles. The other cells are Write cycles.
3. The Auto Select addresses and data are given in [Table 6: Read electronic signature - auto select mode - programmer method \(8-bit mode\)](#), and [Table 8: Block protection - auto select mode - programmer method \(8-bit mode\)](#), except for A9 that is 'Don't care'.
4. In Unlock Bypass, the first two unlock cycles are no more needed (see [Table 12: Fast Program commands, 8-bit mode](#) and [Table 13: Fast Program commands, 16-bit mode](#)).

Table 11. Standard commands, 16-bit mode

Command		Length	Bus operations ⁽¹⁾											
			1st		2nd		3rd		4th		5th		6th	
			Add	Data	Add	Data	Add	Data	Add	Data	Add	Data	Add	Data
Read/Reset		1	X	F0										
		3	555	AA	2AA	55	X	F0						
Auto Select	Manufacturer code	3	555	AA	2AA	55	555	90	(2)(3)	(2)(3)				
	Device code													
	Extended memory block protection indicator													
	Block protection status													
Program ⁽⁴⁾		4	555	AA	2AA	55	555	A0	PA	PD				
Chip Erase		6	555	AA	2AA	55	555	80	555	AA	2AA	55	555	10
Block Erase		6+	555	AA	2AA	55	555	80	555	AA	2AA	55	BAd	30
Erase/Program Suspend		1	X	B0										
Erase/Program Resume		1	X	30										
Read CFI Query		1	55	98										

1. X Don't care, PA Program Address, PD Program Data, BAd any address in the Block. All values in the table are in hexadecimal.
2. These cells represent Read cycles. The other cells are Write cycles.
3. The Auto Select addresses and data are given in [Table 7: Read electronic signature - auto select mode - programmer method \(16-bit mode\)](#), and [Table 9: Block protection - auto select mode - programmer method \(16-bit mode\)](#), except for A9 that is 'Don't care'.
4. In Unlock Bypass, the first two unlock cycles are no more needed (see [Table 12](#) and [Table 13](#) Fast Program commands, 8-bit and 16-bit mode).

6.2 Fast Program commands

The M29W128GH/L offers a set of Fast Program commands to improve the programming throughput:

- Write to Buffer Program
- Enhanced Buffered Program (valid in x 16 mode only)
- Unlock Bypass.

See either [Table 12](#), [Table 13](#) or [Table 14](#) depending on the configuration that is being used, for a summary of the Fast Program commands.

When V_{PPH} is applied to the V_{PP}/\overline{WP} pin the memory automatically enters Unlock Bypass mode (see [Section 6.2.6: Unlock Bypass command](#)).

After programming has started, Bus Read operations in the memory output the Status Register content. Write to Buffer Program command can be suspended and then resumed by issuing a Program Suspend command and a Program Resume command, respectively (see [Section 6.1.8: Program Suspend command](#) and [Section 6.1.9: Program Resume command](#)).

After the fast program operation has completed, the memory will return to the Read mode, unless an error has occurred. When an error occurs Bus Read operations to the memory will continue to output the Status Register. A Read/Reset command must be issued to reset the error condition and return to Read mode. One of the Erase commands must be used to set all the bits in a block or in the whole memory from '0' to '1'.

Typical program times are given in [Table 17: Program, Erase times and Program, Erase endurance cycles](#).

6.2.1 Write to Buffer Program command

The Write to Buffer Program command makes use of the device's 32-word/64-byte write buffer to speed up programming. 32 words/64 bytes can be loaded into the write buffer. Each write buffer has the same A22-A5 addresses. The Write to Buffer Program command dramatically reduces system programming time compared to the standard non-buffered Program command.

When issuing a Write to Buffer Program command, the V_{PP}/\overline{WP} pin can be either held High, V_{IH} , or raised to V_{PPH} .

See [Table 17](#) for details on typical Write to Buffer Program times in both cases.

Five successive steps are required to issue the Write to Buffer Program command:

1. The Write to Buffer Program command starts with two unlock cycles
2. The third Bus Write cycle sets up the Write to Buffer Program command. The setup code can be addressed to any location within the targeted block
3. The fourth Bus Write cycle sets up the number of words/bytes to be programmed. Value N is written to the same block address, where N+1 is the number of words/bytes to be programmed. N+1 must not exceed the size of the write buffer or the operation will abort
4. The fifth cycle loads the first address and data to be programmed
5. Use N Bus Write cycles to load the address and data for each word/byte into the write buffer. Addresses must lie within the range from the start address+1 to the start address + N-1. Optimum performance is obtained when the start address corresponds

to a 32-word/64-byte boundary. If the start address is not aligned to a 32-word/64-byte boundary, the total programming time is doubled.

All the addresses used in the Write to Buffer Program operation must lie within the same page.

To program the content of the write buffer, this command must be followed by a Write to Buffer Program Confirm command.

If an address is written several times during a Write to Buffer Program operation, the address/data counter will be decremented at each data load operation and the data will be programmed to the last word loaded into the buffer.

Invalid address combinations or failing to follow the correct sequence of Bus Write cycles will abort the Write to Buffer Program.

The Status Register bits DQ1, DQ5, DQ6, DQ7 can be used to monitor the device status during a Write to Buffer Program operation.

It is possible to detect Program operation fails when changing programmed data from '0' to '1', that is when reprogramming data in a portion of memory already programmed. The resulting data will be the logical OR between the previous value and the current value.

See [Appendix D, Figure 28: Write to Buffer Program flowchart and pseudocode](#), for a suggested flowchart on using the Write to Buffer Program command.

6.2.2 Enhanced Buffered Program command

The Enhanced Buffered Program command, available only in x 16 mode, makes use of the device's 256-word write buffer to speed up programming. 256 words can be loaded into the write buffer. Each write buffer has the same A22-A8 addresses. The Enhanced Buffered Program command dramatically reduces system programming time compared to both the standard non-buffered Program command and the Write to Buffer command.

When issuing an Enhanced Buffered Program command, the V_{PP}/\overline{WP} pin can be either held High, V_{IH} , or raised to V_{PPH} .

See [Table 17: Program, Erase times and Program, Erase endurance cycles](#) for details on typical Enhanced Buffered Program times in both cases.

Three successive steps are required to issue the Enhanced Buffered Program command:

- The Enhanced Buffered Program command starts with two unlock cycles
- The third Bus Write cycle sets up the Enhanced Buffered Program command. The setup code can be addressed to any location within the targeted block
- The fourth Bus Write cycle loads the first address and data to be programmed. There a total of 256 address and data loading cycles.

To program the content of the write buffer, the Enhanced Buffered Program command must be followed by an Enhanced Buffered Program Confirm command. The command ends with an internal Enhanced Buffered Program Confirm cycle.

Note that address/data cycles must be loaded in an increasing address order (from $ADD[7:0]=00000000$ to $ADD[7:0]=11111111$) and completely (all 256 words). Invalid address combinations or failing to follow the correct sequence of Bus Write cycles will abort the Enhanced Buffered Program.

The Status Register bits DQ1, DQ5, DQ6, and DQ7 can be used to monitor the device status during an Enhanced Buffered Program operation.

An external supply (12 V) can be used to improve programming efficiency.

It is possible to detect Program operation fails when changing programmed data from '0' to '1', that is when reprogramming data in a portion of memory already programmed. The resulting data will be the logical OR between the previous and the current value.

See [Appendix D](#) and [Figure 29: Enhanced Buffered Program flowchart and pseudocode](#), for a suggested flowchart on using the Enhanced Buffered Program command.

6.2.3 Buffered Program Abort and Reset command

A Buffered Program Abort and Reset command must be issued to abort the Write to Buffer Program and Enhanced Buffered Program operation and reset the device in Read mode.

The write to buffer and enhanced buffered programming sequence can be aborted in the following ways:

- Load a value that is greater than the page buffer size during the number of locations to program step in the Write to Buffer Program command
- Write to an address in a block different than the one specified during the write-buffer-load command
- Write an address/data pair to a different write-buffer-page than the one selected by the starting address during the write buffer data loading stage of the operation
- Write data other than the Confirm command after the specified number of data load cycles
- Load address/data pairs in an incorrect sequence during the enhanced buffered program.

The abort condition is indicated by $DQ1 = 1$, $DQ7 = \overline{DQ7}$ (for the last address location loaded), $DQ6 = \text{toggle}$, and $DQ5 = 0$ (all of which are Status Register bits). A Buffered Program Abort and Reset command sequence must be written to reset the device for the next operation. Note that the full 3-cycle Buffered Program Abort and Reset command sequence is required when using write to buffer and enhanced buffered programming features in Unlock Bypass mode.

Note: Enhanced Buffered Program commands are available for x 16 mode only.

6.2.4 Write to Buffer Program Confirm command

The Write to Buffer Program Confirm command is used to confirm a Write to Buffer Program command and to program the N+1 words/bytes loaded in the write buffer by this command.

6.2.5 Enhanced Buffered Program Confirm command

The Enhanced Buffered Program Confirm command is used to confirm an Enhanced Buffered Program command and to program the 256 words loaded in the buffer.

6.2.6 Unlock Bypass command

The Unlock Bypass command is used to place the device in Unlock Bypass mode. When the device enters the Unlock Bypass mode, the two initial unlock cycles required in the standard program command sequence are no more needed, and only two write cycles are required to program data, instead of the normal four cycles (see [Note 4](#) below [Table 10](#) and [Table 11](#)). This results in a faster total programming time.

Unlock Bypass command is consequently used in conjunction with the Unlock Bypass Program command to program the memory faster than with the standard program commands. When the cycle time to the device is long, considerable time saving can be made by using these commands. Three Bus Write operations are required to issue the Unlock Bypass command.

When in Unlock Bypass mode, only the Unlock Bypass Program, Unlock Bypass Block Erase, Unlock Bypass Chip Erase, and Unlock Bypass Reset commands are valid:

- The Unlock Bypass Program command can be issued to program addresses within the memory
- The Unlock Bypass Block Erase command can then be issued to erase one or more memory blocks
- The Unlock Bypass Chip Erase command can be issued to erase the whole memory array
- The Unlock Bypass Write to Buffer Program command can be issued to speed up programming operation
- The Unlock Bypass Enhanced Buffered Program command can be issued to speed up programming operation
- The Unlock Bypass Reset command can be issued to return the memory to Read mode.

In Unlock Bypass mode the memory can be read as if in Read mode.

6.2.7 Unlock Bypass Program command

The Unlock Bypass Program command can be used to program one address in the memory array at a time. The command requires two Bus Write operations, the final write operation latches the address and data and starts the Program/Erase controller.

The Program operation using the Unlock Bypass Program command behaves identically to the Program operation using the Program command. The operation cannot be aborted, a Bus Read operation to the memory outputs the Status Register. See the Program command for details on the behavior.

6.2.8 Unlock Bypass Block Erase command

The Unlock Bypass Block Erase command can be used to Erase one or more memory blocks at a time. The command requires two Bus Write operations instead of six using the standard Block Erase command. The final Bus Write operation latches the address of the block and starts the Program/Erase controller.

To erase multiple block (after the first two Bus Write operations have selected the first block in the list), each additional block in the list can be selected by repeating the second Bus Write operation using the address of the additional block.

The Unlock Bypass Block Erase command behaves in the same way as the Block Erase command: the operation cannot be aborted, and a Bus Read operation to the memory outputs the Status Register (see [Section 6.1.5: Block Erase command](#) for details).

6.2.9 Unlock Bypass Chip Erase command

The Unlock Bypass Chip Erase command can be used to erase all memory blocks at a time. The command requires two Bus Write operations only instead of six using the standard Chip Erase command. The final Bus Write operation starts the Program/Erase controller.

The Unlock Bypass Chip Erase command behaves in the same way as the Chip Erase command: the operation cannot be aborted, and a Bus Read operation to the memory outputs the Status Register (see [Section 6.1.4: Chip Erase command](#) for details).

6.2.10 Unlock Bypass Write to Buffer Program command

The Unlock Bypass Write to Buffer command can be used to program the memory in Fast Program mode. The command requires two Bus Write operations less than the standard Write to Buffer Program command.

The Unlock Bypass Write to Buffer Program command behaves in the same way as the Write to Buffer Program command: the operation cannot be aborted and a Bus Read operation to the memory outputs the Status Register (see [Section 6.2.1: Write to Buffer Program command](#) for details).

The Write to Buffer Program Confirm command is used to confirm an Unlock Bypass Write to Buffer Program command and to program the N+1 words/bytes loaded in the write buffer by this command.

6.2.11 Unlock Bypass Enhanced Buffered Program command

The Unlock Bypass Enhanced Buffered Program command can be used to program the memory in Fast Program mode. The command requires two address/data loading cycles less than the standard Enhanced Buffered Program command (see [Table 14: Enhanced Buffered Program commands, 16-bit mode](#)).

The Unlock Bypass Enhanced Buffered Program command behaves identically to the Enhanced Buffered Program operation using the Enhanced Buffered Program command. The operation cannot be aborted and a Bus Read operation to the memory outputs the Status Register (see [Section 6.2.2: Enhanced Buffered Program command](#) for details on the behavior).

The Enhanced Buffered Program Confirm command is used to confirm an Unlock Bypass Enhanced Buffered Program command and to program the 256 words loaded in the buffer.

6.2.12 Unlock Bypass Reset command

The Unlock Bypass Reset command can be used to return to Read/Reset mode from Unlock Bypass mode. Two Bus Write operations are required to issue the Unlock Bypass Reset command. Read/Reset command does not exit from Unlock Bypass mode.

Table 12. Fast Program commands, 8-bit mode

Command	Length	Bus Write operations ⁽¹⁾																	
		1st		2nd		3rd		4th		5th		6th		7th		8th		9th	
		Add	Data	Add	Data	Add	Data	Add	Data	Add	Data	Add	Data	Add	Data	Add	Data	Add	Data
Write to Buffer Program	N+5	AAA	AA	555	55	BAd	25	BAd	N ⁽²⁾	PA ⁽³⁾	PD	WBL ⁽⁴⁾	PD						
Write to Buffer Program Confirm	1	BAd ⁽⁵⁾	29																
Buffered Program Abort and Reset	3	AAA	AA	555	55	AAA	F0												
Unlock Bypass	3	AAA	AA	555	55	AAA	20												
Unlock Bypass Program	2	X	A0	PA	PD														
Unlock Bypass Block Erase	2+	X	80	BAd	30														
Unlock Bypass Chip Erase	2	X	80	X	10														
Unlock Bypass Write to Buffer Program	N+3	BAd	25	BAd	N ⁽²⁾	PA ⁽³⁾	PD	WBL ⁽⁶⁾	PD										
Unlock Bypass Reset	2	X	90	X	00														

1. X Don't care, PA Program Address, PD Program Data, BAd Any address in the Block, WBL Write Buffer Location. All values in the table are in hexadecimal.
2. The maximum number of cycles in the command sequence is 68. N+1 is the number of bytes to be programmed during the Write to Buffer Program operation.
3. Each buffer has the same A22-A5 addresses. A0-A4 and A-1 are used to select a byte within the N+1 byte page.
4. The 6th cycle has to be issued N time. WBL scans the word inside the page.
5. BAd must be identical to the address loaded during the Write to Buffer Program 3rd and 4th cycles.
6. The 4th cycle has to be issued N time. WBL scans the word inside the page.

Table 13. Fast Program commands, 16-bit mode

Command	Length	Bus Write operations ⁽¹⁾											
		1st		2nd		3rd		4th		5th		6th	
		Add	Data	Add	Data	Add	Data	Add	Data	Add	Data	Add	Data
Write to Buffer Program	N+5	555	AA	2AA	55	BAd	25	BAd	N ⁽²⁾	PA ⁽³⁾	PD	WBL ⁽⁴⁾	PD
Write to Buffer Program Confirm	1	BAd ⁽⁵⁾	29										
Buffered Program Abort and Reset	3	555	AA	2AA	55	555	F0						
Unlock Bypass	3	555	AA	2AA	55	555	20						
Unlock Bypass Program	2	X	A0	PA	PD								
Unlock Bypass Block Erase	2+	X	80	BAd	30								
Unlock Bypass Chip Erase	2	X	80	X	10								
Unlock Bypass Write to Buffer Program	N+3	BAd	25	BAd	N ⁽²⁾	PA ⁽³⁾	PD	WBL ⁽⁶⁾	PD				
Unlock Bypass Reset	2	X	90	X	00								

1. X Don't care, PA Program Address, PD Program Data, BAd Any address in the Block, WBL Write Buffer Location. All values in the table are in hexadecimal.
2. The maximum number of cycles in the command sequence is 36. N+1 is the number of words to be programmed during the Write to Buffer Program operation.
3. Each buffer has the same A22-A5 addresses. A0-A4 are used to select a word within the N+1 word page.
4. The 6th cycle has to be issued N time. WBL scans the word inside the page.
5. BAd must be identical to the address loaded during the Write to Buffer Program 3rd and 4th cycles.

Table 14. Enhanced Buffered Program commands, 16-bit mode⁽¹⁾

Command	Length	Bus Write operations																	
		1st		2nd		3rd		4th		...		257th		258th		259th		260th	
		Add	Data	Add	Data	Add	Data	Add	Data	Add	Data	Add	Data	Add	Data	Add	Data	Add	Data
Enhanced Buffered Program	259	555	AA	2AA	55	BAd	33	BAd (00)	Data					BAd (FF)	Data		
Enhanced Buffered Program Confirm	1	BAd (00)	29																
Unlock Bypass Enhanced Buffered Program	257	BAd	33	BAd (00)	Data							BAd (FF)	Data						

1. Only available from week 8 of 2008.

6.3 Protection commands

Blocks can be protected individually against accidental program, erase or read operations. The device block protection scheme is shown in [Figure 5: Software protection scheme](#). See either [Table 15](#), or [Table 16](#), depending on the configuration that is being used, for a summary of the Block Protection commands.

Block protection commands are available both in 8-bit and 16-bit configuration.

The memory block and Extended Memory block protection is configured through the Lock register (see [Section 7.1: Lock Register](#)).

6.3.1 Enter Extended Memory Block command

The M29W128GH/L has one extra 128-word block (extended memory block) that can only be accessed using the Enter Extended Memory Block command.

Three Bus Write cycles are required to issue the Extended Memory Block command. Once the command has been issued the device enters the Extended Memory Block mode where all Bus Read or Program operations are conducted on the extended memory block. Once the device is in the Extended Block mode, the extended memory block is addressed by using the addresses occupied by block 0 in the other operating modes (see [Table 34: Block addresses](#)).

The device remains in Extended Memory Block mode until the Exit Extended Memory Block command is issued or power is removed from the device. After power-up or a hardware reset, the device reverts to the Read mode, and the commands issued to block 0 addresses will properly address block 0.

The extended memory block cannot be erased, and can be treated as one-time programmable (OTP) memory.

In Extended Block mode, Erase, Chip Erase, Erase Suspend and Erase Resume commands are not allowed.

To exit from the Extended Memory Block mode the Exit Extended Memory Block command must be issued.

The Extended Memory Block can be protected by setting the Extended Memory Block Protection bit to '1' (see [Section 7.1: Lock Register](#)); however once protected the protection cannot be undone.

Note: When the device is in the Extended Memory Block mode, the $V_{PP}\overline{WP}$ pin cannot be used for fast programming and the Unlock Bypass mode is not available (see [Section 2.8: VPP/Write Protect \(VPP/WP\)](#)).

6.3.2 Exit Extended Memory Block command

The Exit Extended Memory Block command is used to exit from the Extended Memory Block mode and return the device to Read mode. Four Bus Write operations are required to issue the command.

6.3.3 Lock Register command set

The M29W128GL and M29W128GH offer a set of commands to access the Lock Register and to configure and verify its content. See the following sections in conjunction with [Section 7.1: Lock Register](#), [Table 15](#) and [Table 16](#).

Enter Lock Register Command Set command

Three Bus Write cycles are required to issue the Enter Lock Register Command Set command. Once the command has been issued, all Bus Read or Program operations are issued to the Lock Register.

Lock Register Program and Lock Register Read command

The Lock Register Program command allows to configure the Lock Register. The programmed data can then be checked by issuing a Lock Register Read command.

An Exit Protection Command Set command must then be issued to return the device to Read mode (see [Section 6.3.8: Exit Protection command set](#)).

6.3.4 Password Protection mode command set

Enter Password Protection Command Set command

Three Bus Write cycles are required to issue the Enter Password Protection Command Set command. Once the command has been issued, the commands related to the Password Protection mode can be issued to the device.

Password Program command

The Password Program command is used to program the 64-bit password used in the Password Protection mode.

To program the 64-bit password, the complete command sequence must be entered eight times at eight consecutive addresses selected by A1-A0 plus DQ15A-1 in 8-bit mode, or four times at four consecutive addresses selected by A1-A0 in 16-bit mode.

The password can be checked by issuing a Password Read command.

Once Password Program operation has completed, an Exit Protection Command Set command must be issued to return the device to Read mode. The Password Protection mode can then be selected.

By default, all Password bits are set to '1'.

Password Read command

The Password Read command is used to verify the Password used in Password Protection mode.

To verify the 64-bit password, the complete command sequence must be entered eight times at eight consecutive addresses selected by A1-A0 plus DQ15A-1 in 8-bit mode, or four times at four consecutive addresses selected by A1-A0 in 16-bit mode.

If the Password Mode Lock bit is programmed and the user attempts to read the password, the device will output FFh onto the I/O data bus.

An Exit Protection Command Set command must be issued to return the device to Read mode.

Password Unlock command

The Password Unlock command is used to clear the NVPB Lock bit allowing to modify the NVPBs.

The Password Unlock command must be issued along with the correct password.

There must be a 1 μ s delay between successive Password Unlock commands in order to prevent hackers from cracking the password by trying all possible 64-bit combinations. If this delay is not respected, the latest command will be ignored.

Approximately 1 μ s is required for unlocking the device after the valid 64-bit password has been provided.

6.3.5 Non-volatile Protection mode command set**Enter Non-volatile Protection Command Set command**

Three Bus Write cycles are required to issue the Enter Non-volatile Protection Command Set command. Once the command has been issued, the commands related to the Non-Volatile Protection mode can be issued to the device.

Non-volatile Protection Bit Program command (NVPB Program)

A block can be protected from program or erase by issuing a Non-volatile Protection Bit command along with the block address. This command sets the NVPB to '1' for a given block.

Read Non-volatile Protection Bit Status command (Read NVPB Status)

The status of a NVPB for a given block or group of blocks can be read by issuing a Read Non-Volatile Modify Protection Bit command along with the block address.

Clear all Non-volatile Protection Bits command (Clear all NVPBs)

The NVPBs are erased simultaneously by issuing a Clear all Non-volatile Protection Bits command. No specific block address is required. If the NVPB Lock bit is set to '0', the command fails.

Figure 6. NVPB Program/Erase algorithm

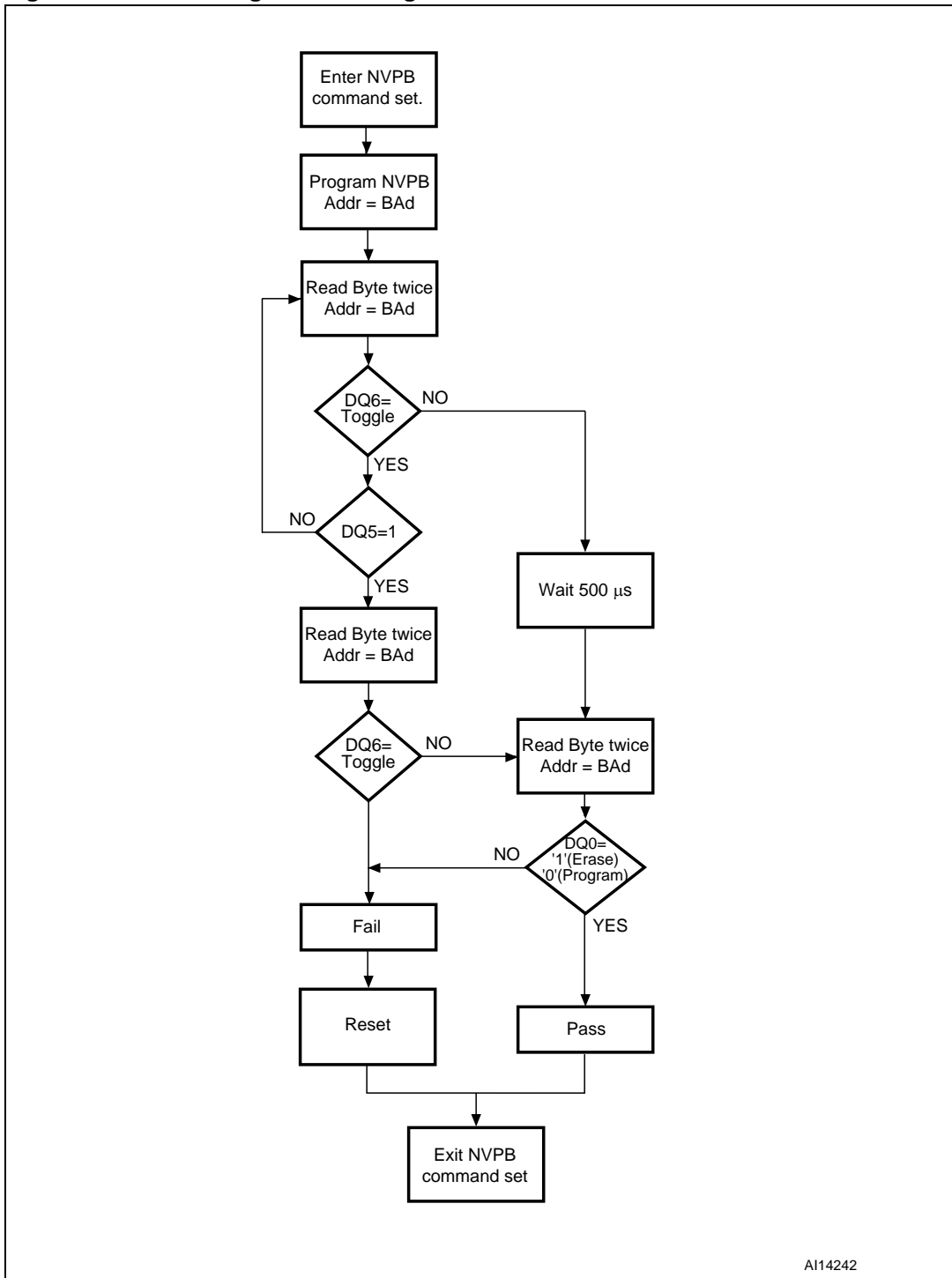

A114242

6.3.6 NVPB Lock Bit command set

Enter NVPB Lock Bit Command Set command

Three bus Write cycles are required to issue the Enter NVPB Lock Bit Command Set command. Once the command has been issued, the commands allowing to set the NVPB Lock bit can be issued to the device.

NVPB Lock Bit Program command

This command is used to set the NVPB Lock bit to '0' thus locking the NVPBs, and preventing them from being modified.

Read NVPB Lock Bit Status command

This command is used to read the status of the NVPB Lock bit.

6.3.7 Volatile Protection mode command set

Enter Volatile Protection Command Set command

Three bus Write cycles are required to issue the Enter Volatile Protection Command Set command. Once the command has been issued, the commands related to the Volatile Protection mode can be issued to the device.

Volatile Protection Bit Program command (VPB Program)

The VPB Program command individually sets a VPB to '0' for a given block.

If the NVPB for the same block is set, the block is locked regardless of the value of the VPB bit. (see [Table 19: Block protection status](#)).

Read VPB Status command

The status of a VPB for a given block can be read by issuing a Read VPB Status command along with the block address.

VPB Clear command

The VPB Clear command individually clears (sets to '1') the VPB for a given block.

If the NVPB for the same block is set, the block is locked regardless of the value of the VPB bit. (see [Table 19: Block protection status](#)).

6.3.8 Exit Protection command set

The Exit Protection Command Set command is used to exit from the Lock Register, Password Protection, Non-Volatile Protection, Volatile Protection, and NVPB Lock Bit Command Set mode. It return the device to Read mode.

Table 15. Block Protection commands, 8-bit mode⁽¹⁾⁽²⁾⁽³⁾

Command	Length	Bus operations																					
		1st		2nd		3rd		4th		5th		6th		7th		8th		9th		10th		11th	
		Ad	Data	Ad	Data	Ad	Data	Ad	Data	Ad	Data	Ad	Data	Ad	Data	Ad	Data	Ad	Data	Ad	Data	Ad	Data
Lock Register	Enter Lock Register Command Set ⁽⁴⁾	3	AAA	AA	555	55	AAA	40															
	Lock Register Program	2	X	A0	X	DATA ⁽⁵⁾																	
	Lock Register Read	1	X	DATA ⁽⁵⁾																			
Password Protection	Enter Password Protection Command Set ⁽⁴⁾	3	AAA	AA	555	55	AAA	60															
	Password Program ⁽⁶⁾⁽⁷⁾	2	X	A0	PWA _n	PWD _n																	
	Password Read	8	00	PWD ₀	01	PWD ₁	02	PWD ₂	03	PWD ₃	04	PWD ₄	05	PWD ₅	06	PWD ₆	07	PWD ₇					
	Password Unlock ⁽⁷⁾	1	00	25	00	03	00	PWD ₀	01	PWD ₁	02	PWD ₂	03	PWD ₃	04	PWD ₄	05	PWD ₅	06	PWD ₆	07	PWD ₇	00
Non-volatile Protection	Enter Non-Volatile Protection Command Set ⁽⁴⁾	3	AAA	AA	555	55	AAA	C0															
	NVPB Program ⁽⁸⁾	2	X	A0	BAd	00																	
	Clear all NVPBs ⁽⁹⁾	2	X	80	00	30																	
	Read NVPB Status ⁽⁸⁾	1	BAd	RD(0)																			
NVPB Lock bit	Enter NVPB Lock Bit Command Set	3	AAA	AA	555	55	AAA	50															
	NVPB Lock Bit Program ⁽⁶⁾	2	X	A0	X	00																	
	Read NVPB Lock Bit Status ⁽⁸⁾	1	X	RD(0)																			
Volatile Protection	Enter Volatile Protection Command Set	3	AAA	AA	555	55	AAA	E0															
	VPB Program ⁽⁶⁾	2	X	A0	BAd	00																	
	Read VPB Status	1	X	RD(0)																			
	VPB Clear ⁽⁶⁾	2	X	A0	BAd	01																	
Exit Protection Command Set ⁽¹⁰⁾	2	X	90	X	00																		
Enter Extended Block ⁽⁴⁾	3	AAA	AA	555	55	AAA	88																
Exit Extended Block	4	AAA	AA	555	55	AAA	90	X	00														

1. Ad address, Dat data, BAd Any address in the Block, RD Read data, PWD_n Password byte 0 to 7, PWA_n Password Address (n = 0 to 7), X Don't care. All values in the table are in hexadecimal.

2. Grey cells represent Read cycles. The other cells are Write cycles.
3. DQ15 to DQ8 are 'Don't care' during unlock and command cycles. A22 to A16 are 'Don't care' during unlock and command cycles unless an address is required.
4. An Enter command sequence must be issued prior to any operation. It disables read and write operations from and to block 0. Read and write operations from any other block are allowed.
5. DATA = Lock Register content.
6. Only one portion of password can be programmed or read by each Password Program command.
7. The password portion can be entered or read in any order as long as the entire 64-bit password is entered or read.
8. Protected and unprotected states correspond to 00 and 01, respectively.
9. The Clear all NVPBs command programs all NVPBs before erasure in order to prevent the over-erasure of previously cleared Non Volatile Modify Protection bits.
10. If an Entry Command Set command is issued, an Exit Protection Command Set command must be issued to return the device to Read mode.

Table 16. Block Protection commands, 16-bit mode⁽¹⁾⁽²⁾⁽³⁾

Command	Length	Bus operations														
		1st		2nd		3rd		4th		5th		6th		7th		
		Ad	Data	Ad	Data	Ad	Data	Ad	Data	Ad	Data	Ad	Data	Ad	Data	
Lock register	Enter Lock Register Command Set ⁽⁴⁾	3	555	AA	2AA	55	555	40								
	Lock Register Program	2	X	A0	X	DATA ⁽⁵⁾										
	Lock Register Read	1	X	DATA ⁽⁵⁾												
Password Protection	Enter Password Protection Command Set ⁽⁴⁾	3	555	AA	2AA	55	555	60								
	Password Program ⁽⁶⁾⁽⁷⁾	2	X	A0	PWAn	PWDn										
	Password Read	4	00	PWD0	01	PWD1	02	PWD2	03	PWD3						
	Password Unlock ⁽⁷⁾	7	00	25	00	03	00	PWD0	01	PWD1	02	PWD2	03	PWD3	00	29
Non-Volatile Protection	Enter Non-volatile Protection Command Set ⁽⁴⁾	3	555	AA	2AA	55	555	C0								
	NVPB Program ⁽⁸⁾	2	X	A0	BAd	00										
	Clear all NVPBs ⁽⁹⁾	2	X	80	00	30										
	Read NVPB Status	1	BAd	RD(0)												
NVPB Lock bit	Enter NVPB Lock Bit Command Set	3	555	AA	2AA	55	555	50								
	NVPB Lock Bit Program	2	X	A0	X	00										
	Read NVPB Lock Bit Status	1	X	RD(0)												
Volatile Protection	Enter Volatile Protection Command Set	3	555	AA	2AA	55	555	E0								
	VPB Program	2	X	A0	BAd	00										
	Read VPB Status	1	X	RD(0)												
	VPB Clear	2	X	A0	BAd	01										
Exit Protection Command Set ⁽¹⁰⁾	2	X	90	X	00											
Enter Extended Block ⁽⁴⁾	3	555	AA	2AA	55	555	88									
Exit Extended Block	4	555	AA	2AA	55	555	90	X	00							

1. Ad address, Dat data, BAd Any address in the Block, RD Read data, PWDn Password word 0 to 3, PWAn Password Address (n = 0 to 3), X Don't care. All values in the table are in hexadecimal.
2. Grey cells represent Read cycles. The other cells are Write cycles.
3. DQ15 to DQ8 are 'Don't care' during unlock and command cycles. A22 to A16 are 'Don't care' during unlock and command cycles unless an address is required.
4. An Enter command sequence must be issued prior to any operation. It disables read and write operations from and to block 0. Read and write operations from any other block are allowed.
5. DATA = Lock Register content.
6. Only one portion of password can be programmed or read by each Password Program command.
7. The password portion can be entered or read in any order as long as the entire 64-bit password is entered or read.
8. Protected and unprotected states correspond to 00 and 01, respectively.
9. The Clear all NVPBs command programs all NVPBs before erasure in order to prevent the over-erasure of previously cleared Non-volatile Modify Protection bits.
10. If an Entry Command Set command is issued, an Exit Protection Command Set command must be issued to return the device to Read mode.

Table 17. Program, Erase times and Program, Erase endurance cycles

Parameter		Min	Typ ⁽¹⁾⁽²⁾	Max ⁽²⁾	Unit
Chip Erase			40	400 ⁽³⁾	s
Block Erase (128 kbytes) ⁽⁴⁾			0.5		s
Erase Suspend latency time			25	35	µs
Block Erase timeout		50			µs
Byte Program	Single Byte Program		16	200 ⁽³⁾	µs
	Write to Buffer Program (64 bytes at-a-time)	$V_{PP}/\overline{WP} = V_{PPH}$	51		µs
		$V_{PP}/\overline{WP} = V_{IH}$	78		
Word Program	Single Word Program		16	200 ⁽³⁾	µs
	Write to Buffer Program (32 words at-a-time)	$V_{PP}/\overline{WP} = V_{PPH}$	51		µs
		$V_{PP}/\overline{WP} = V_{IH}$	78		
Chip Program (byte by byte)			270	800 ⁽³⁾	s
Chip Program (word by word)			135	400 ⁽³⁾	s
Chip Program (Write to Buffer Program) ⁽⁵⁾			20	200 ⁽³⁾	s
Chip Program (Write to Buffer Program with $V_{PP}/\overline{WP} = V_{PPH}$) ⁽⁵⁾			13	50 ⁽³⁾	s
Chip Program (Enhanced Buffered Program) ⁽⁵⁾			8	40	s
Chip Program (Enhanced Buffered Program with $V_{PP}/\overline{WP} = V_{PP}$) ⁽⁵⁾			5	25	s
Program Suspend latency time			5	15	µs
Program/Erase cycles (per block)		100,000			Cycles
Data retention		20			Years

1. Typical values measured at room temperature and nominal voltages.
2. Sampled, but not 100% tested.
3. Maximum value measured at worst case conditions for both temperature and V_{CC} after 100,000 program/erase cycles.
4. Block Erase Polling cycle time (see [Figure 24: Data polling AC waveforms](#)).
5. Intrinsic program timing, that means without the time required to execute the bus cycles to load the program commands.

7 Registers

The device features two registers:

- A Lock Register that allows to configure the memory blocks and extended memory block protection (see [Table 19: Block protection status](#))
- A Status Register that provides information on the current or previous Program or Erase operations.

7.1 Lock Register

The Lock Register is a 16-bit one-time programmable register. The bits in the Lock Register are summarized in [Table 18: Lock Register bits](#).

See [Section 6.3.3: Lock Register command set](#) for a description of the commands allowing to read and program the Lock Register.

7.1.1 Password Protection Mode Lock bit (DQ2)

The Password Protection Mode Lock bit, DQ0, is one-time programmable. Programming (setting to '0') this bit permanently places the device in Password Protection mode.

Any attempt to program the Password Protection mode Lock bit when the Non-volatile Protection Mode bit is programmed causes the operation to abort and the device to return to Read mode.

7.1.2 Non-volatile Protection Mode Lock bit (DQ1)

The Non-volatile Protection Mode Lock bit, DQ1, is one-time programmable. Programming (setting to '0') this bit permanently places the device in Non-volatile Protection mode.

When shipped from the factory, all parts default to operate in Non-volatile Protection mode. The memory blocks can be either unprotected (NVPBs set to '1') or protected (NVPBs set to '0'), according to the ordering option that has been chosen.

Any attempt to program the Non-volatile Protection mode Lock bit when the Password Protection Mode bit is programmed causes the operation to abort and the device to return to Read mode.

7.1.3 Extended Block Protection bit (DQ0)

If the device has not been shipped with the extended memory block factory locked, the block can be protected by setting the Extended Memory Block Protection bit, DQ0, to '0'.

However, this bit is one-time programmable and once protected the extended memory block cannot be unprotected.

The extended memory block protection status can be read in Auto Select mode either by applying V_{ID} to A9 (see [Table 8](#) and [Table 9](#)) or by issuing an Auto Select command (see [Table 10](#) and [Table 11](#)).

7.1.4 DQ15 to DQ3 reserved

They are 'Don't care'.

Table 18. Lock Register bits⁽¹⁾

DQ15-3	DQ2	DQ1	DQ0
Don't care	Password Protection Mode Lock bit	Non-volatile Protection Mode Lock bit	Extended Block Protection bit

1. DQ0, DQ1 and DQ2 Lock Register bits are set to '1' when shipped from the factory.

Table 19. Block protection status

NVPB Lock bit ⁽¹⁾	Block NVPB ⁽²⁾	Block VPB ⁽³⁾	Block protection status	Block protection status
0	0	x	01h	Block protected (non-volatile protection through NVPB)
0	1	1	00h	Block unprotected
0	1	0	00h	Block protected (volatile protection through VPB)
1	0	x	01h	Block protected (non-volatile protection through NVPB)
1	1	0	01h	Block protected (volatile protection through VPB)
1	1	1	00h	Block unprotected

1. If the NVPB Lock bit is set to '0', all NVPBs are locked. If the NVPB Lock bit is set to '1', all NVPBs are unlocked.
2. If the Block NVPB is set to '0', the block is protected, if set to '1', it is unprotected.
3. If the Block VPB is set to '0', the block is protected, if set to '1', it is unprotected.

Figure 7. Lock Register program flowchart

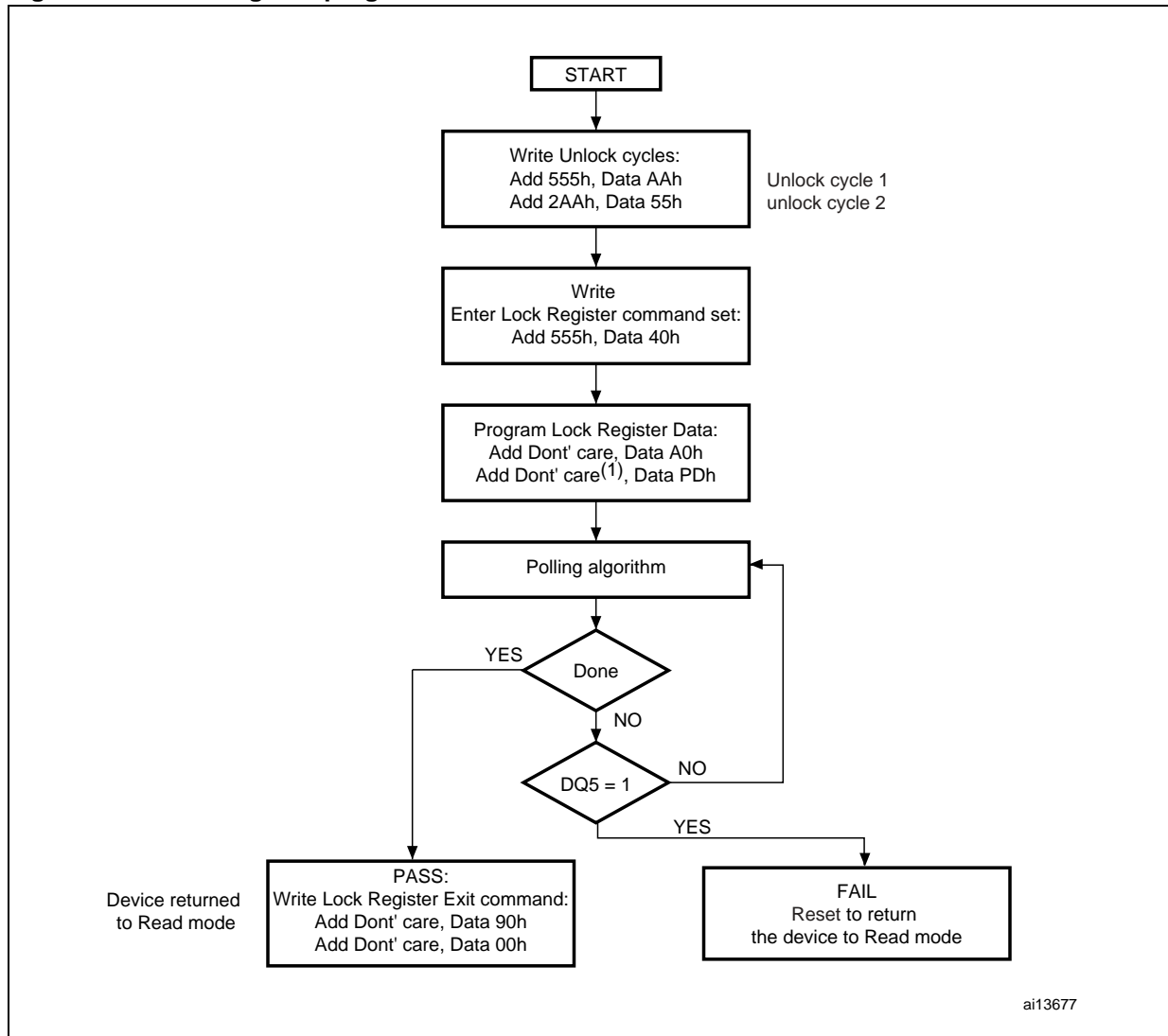

1. PD is the programmed data (see [Table 18: Lock Register bits](#)).
2. The Lock Register can only be programmed once.

7.2 Status Register

The M29W128GH/L has one Status Register. The various bits convey information and errors on the current and previous program/erase operation. Bus Read operations from any address within the memory, always read the Status Register during Program and Erase operations. It is also read during Erase Suspend when an address within a block being erased is accessed.

The bits in the Status Register are summarized in [Table 20: Status Register bits](#).

7.2.1 Data Polling bit (DQ7)

The Data Polling bit can be used to identify whether the Program/Erase controller has successfully completed its operation or if it has responded to an Erase Suspend. The Data Polling bit is output on DQ7 when the Status Register is read.

During Program operations the Data Polling bit outputs the complement of the bit being programmed to DQ7. After successful completion of the Program operation the memory returns to Read mode and Bus Read operations, from the address just programmed, output DQ7, not its complement.

During Erase operations the Data Polling bit outputs '0', the complement of the erased state of DQ7. After successful completion of the Erase operation the memory returns to Read mode.

In Erase Suspend mode the Data Polling bit will output a '1' during a Bus Read operation within a block being erased. The Data Polling bit will change from '0' to '1' when the Program/Erase controller has suspended the Erase operation.

[Figure 8: Data polling flowchart](#), gives an example of how to use the Data Polling bit. A Valid Address is the address being programmed or an address within the block being erased.

7.2.2 Toggle bit (DQ6)

The Toggle bit can be used to identify whether the Program/Erase controller has successfully completed its operation or if it has responded to an Erase Suspend. The Toggle bit is output on DQ6 when the Status Register is read.

During a Program/Erase operation the Toggle bit changes from '0' to '1' to '0', etc., with successive Bus Read operations at any address. After successful completion of the operation the memory returns to Read mode.

During Erase Suspend mode the Toggle bit will output when addressing a cell within a block being erased. The Toggle bit will stop toggling when the Program/Erase controller has suspended the Erase operation.

[Figure 9: Toggle flowchart](#), gives an example of how to use the Data Toggle bit.

7.2.3 Error bit (DQ5)

The Error bit can be used to identify errors detected by the Program/Erase controller. The Error bit is set to '1' when a Program, Block Erase or Chip Erase operation fails to write the correct data to the memory. If the Error bit is set a Read/Reset command must be issued

before other commands are issued. The Error bit is output on DQ5 when the Status Register is read.

Note that the Program command cannot change a bit set to '0' back to '1' and attempting to do so will set DQ5 to '1'. A Bus Read operation to that address will show the bit is still '0'. One of the Erase commands must be used to set all the bits in a block or in the whole memory from '0' to '1'.

7.2.4 Erase Timer bit (DQ3)

The Erase Timer bit can be used to identify the start of Program/Erase controller operation during a Block Erase command. Once the Program/Erase controller starts erasing the Erase Timer bit is set to '1'. Before the Program/Erase controller starts the Erase Timer bit is set to '0' and additional blocks to be erased may be written to the command interface. The Erase Timer bit is output on DQ3 when the Status Register is read.

7.2.5 Alternative Toggle bit (DQ2)

The Alternative Toggle bit can be used to monitor the Program/Erase controller during Erase operations. The Alternative Toggle bit is output on DQ2 when the Status Register is read.

During Chip Erase and Block Erase operations the Toggle bit changes from '0' to '1' to '0', etc., with successive Bus Read operations from addresses within the blocks being erased. A protected block is treated the same as a block not being erased. Once the operation completes the memory returns to Read mode.

During Erase Suspend the Alternative Toggle bit changes from '0' to '1' to '0', etc. with successive Bus Read operations from addresses within the blocks being erased. Bus Read operations to addresses within blocks not being erased will output the memory array data as if in Read mode.

After an Erase operation that causes the Error bit to be set, the Alternative Toggle bit can be used to identify which block or blocks have caused the error. The Alternative Toggle bit changes from '0' to '1' to '0', etc. with successive Bus Read Operations from addresses within blocks that have not erased correctly. The Alternative Toggle bit does not change if the addressed block has erased correctly.

7.3 Buffered Program Abort bit (DQ1)

The Buffered Program Abort bit, DQ1, is set to '1' when a Write to Buffer Program or Enhanced Buffered Program operation aborts. The Buffered Program Abort and Reset command must be issued to return the device to Read mode (see Write to Buffer Program in [Section 6.1: Standard commands](#)).

Table 20. Status Register bits⁽¹⁾

Operation	Address	DQ7	DQ6	DQ5	DQ3	DQ2	DQ1	R \bar{B}
Program ⁽²⁾	Any address	$\overline{DQ7}$	Toggle	0	–	–	0	0
Program During Erase Suspend	Any address	$\overline{DQ7}$	Toggle	0	–	–	–	0
Buffered Program Abort ⁽²⁾	Any address	$\overline{DQ7}$	Toggle	0	–	–	1	0
Program Error	Any address	$\overline{DQ7}$	Toggle	1	–	–	–	Hi-Z
Chip Erase	Any address	0	Toggle	0	1	Toggle	–	0
Block Erase before timeout	Erasing block	0	Toggle	0	0	Toggle	–	0
	Non-erasing block	0	Toggle	0	0	No toggle	–	0
Block Erase	Erasing block	0	Toggle	0	1	Toggle	–	0
	Non-erasing block	0	Toggle	0	1	No toggle	–	0
Erase Suspend	Erasing block	1	No Toggle	0	–	Toggle	–	Hi-Z
	Non-erasing block	Data read as normal					–	Hi-Z
Erase Error	Good block address	0	Toggle	1	1	No toggle	–	Hi-Z
	Faulty Block address	0	Toggle	1	1	Toggle	–	Hi-Z

1. Unspecified data bits should be ignored.

2. $\overline{DQ7}$ for Write to Buffer Program and Enhanced Buffered Program is related to the last address location loaded.

Figure 8. Data polling flowchart

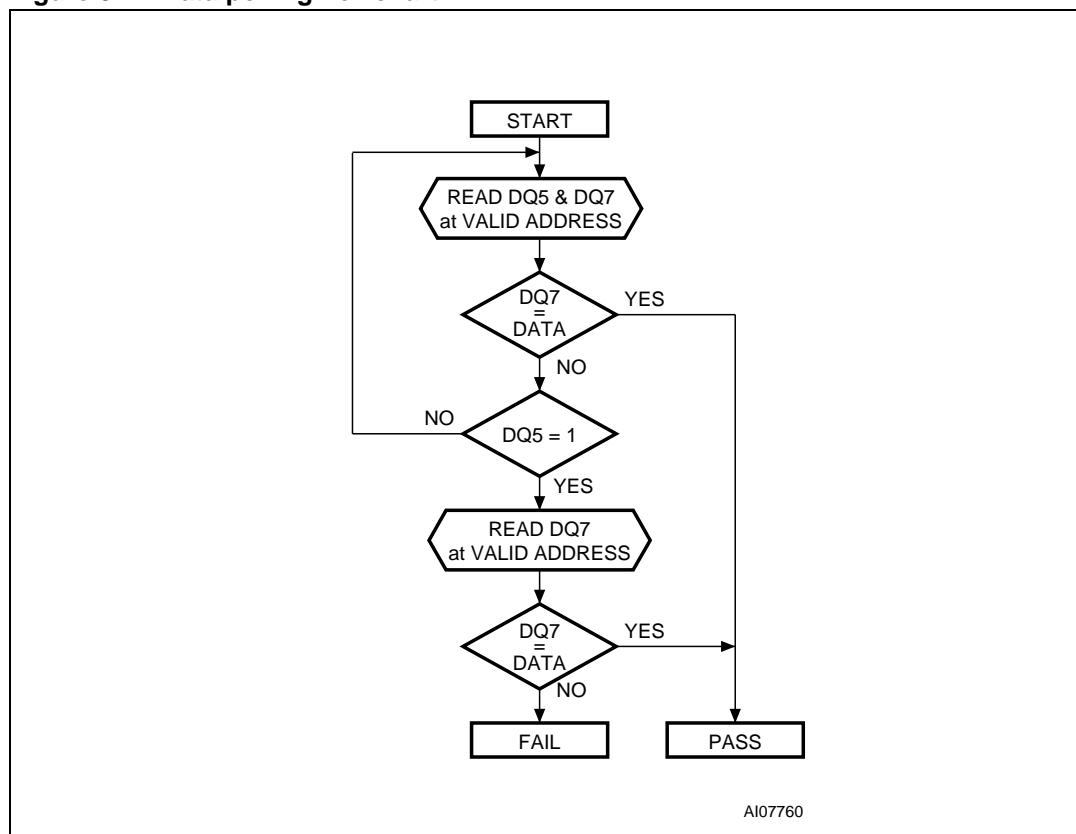
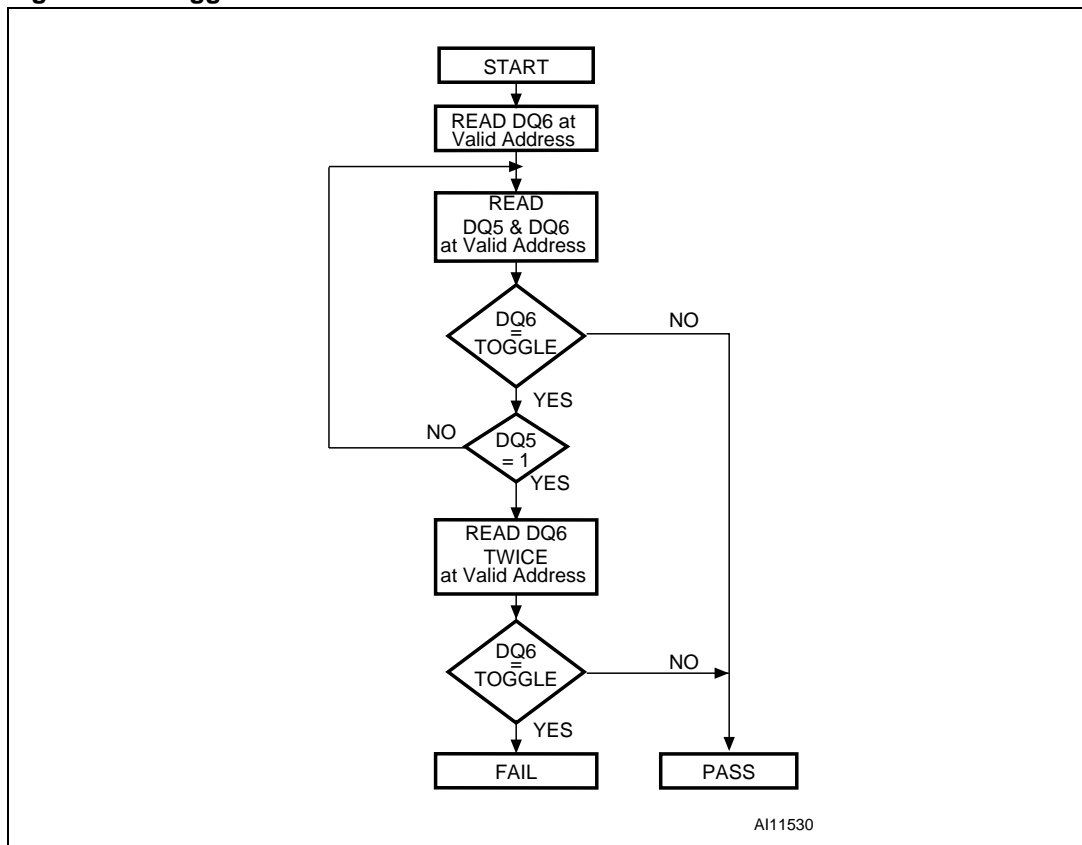

Figure 9. Toggle flowchart



8 Maximum ratings

Stressing the device above the rating listed in [Table 21: Absolute maximum ratings](#) may cause permanent damage to the device. Exposure to absolute maximum rating conditions for extended periods may affect device reliability. These are stress ratings only and operation of the device at these or any other conditions above those indicated in the operating sections of this specification is not implied. Refer also to the STMicroelectronics SURE Program and other relevant quality documents.

Table 21. Absolute maximum ratings

Symbol	Parameter	Min	Max	Unit
T_{BIAS}	Temperature under bias	-50	125	°C
T_{STG}	Storage temperature	-65	150	°C
V_{IO}	Input or output voltage ⁽¹⁾⁽²⁾	-0.6	$V_{CC} + 0.6$	V
V_{CC}	Supply voltage	-0.6	4	V
V_{CCQ}	Input/output supply voltage	-0.6	4	V
V_{ID}	Identification voltage	-0.6	13.5	V
$V_{PPH}^{(3)}$	Program voltage	-0.6	13.5	V

1. Minimum voltage may undershoot to -2 V during transition and for less than 20 ns during transitions.
2. Maximum voltage may overshoot to $V_{CC} + 2$ V during transition and for less than 20 ns during transitions.
3. V_{PPH} must not remain at 12 V for more than a total of 80 hrs.

9 DC and AC parameters

This section summarizes the operating measurement conditions, and the DC and AC characteristics of the device. The parameters in the DC and AC characteristics tables that follow, are derived from tests performed under the measurement conditions summarized in [Table 22: Operating and AC measurement conditions](#). Designers should check that the operating conditions in their circuit match the operating conditions when relying on the quoted parameters.

Table 22. Operating and AC measurement conditions

Parameter	M29W128GH, M29W128GL				Unit
	70 or 60 ⁽¹⁾ ns		80 ns		
	Min	Max	Min	Max	
V _{CC} supply voltage	2.7	3.6	2.7	3.6	V
V _{CCQ} supply voltage (V _{CCQ} ≤ V _{CC})	2.7	3.6	1.65	3.6	V
Ambient operating temperature	- 40	85	- 40	85	°C
Load capacitance (C _L)	30		30		pF
Input rise and fall times		10		10	ns
Input pulse voltages	0 to V _{CCQ}		0 to V _{CCQ}		V
Input and output timing ref. voltages	V _{CCQ} /2		V _{CCQ} /2		V

1. Only available upon customer request.

Figure 10. AC measurement load circuit

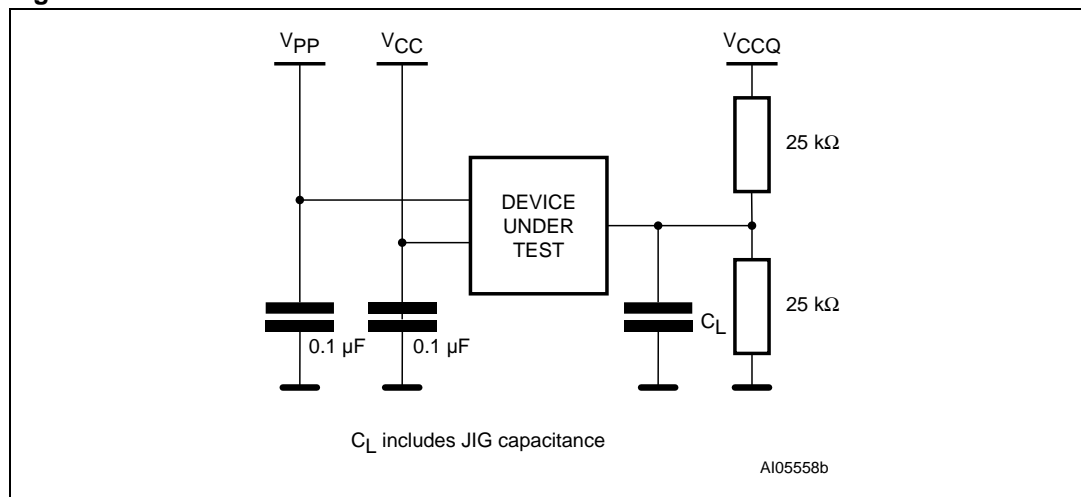

Figure 11. AC measurement I/O waveform

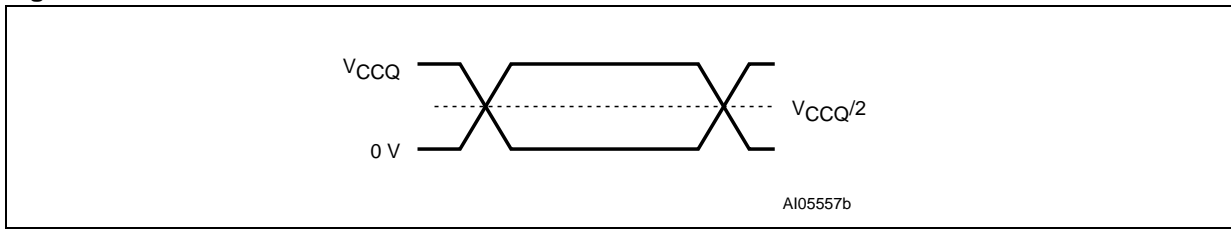

Table 23. Power-up waiting timings

Symbol	Alt.	Parameter	Min	M29W128GH, M29W128GL		Unit
				70 or 60 ⁽¹⁾ ns	80 ns	
$t_{VCHVCQH}$		$V_{CC}^{(2)}$ High to $V_{CCQ}^{(2)}$ High	Min	0		μs
$t_{VCHRHR}^{(3)}$	t_{VCS}	V_{CC} High to rising edge of \overline{RP}	Min	35		μs
$t_{VCQHRHR}^{(3)}$	t_{VIOS}	V_{CCQ} High to rising edge of \overline{RP}	Min	0		μs
t_{RHEL}	t_{RH}	\overline{RP} High to Chip Enable Low	Min	50		μs
t_{RHWL}		\overline{RP} High to Write Enable Low	Min	500		μs

1. Only available upon customer request.
2. V_{CC} and V_{CCQ} ramps must be synchronized during power-up.
3. If RP is not stable for t_{VCHRHR} or $t_{VCQHRHR}$, the device does not permit any Read and Write operations and a hardware reset is required.

Figure 12. Power-up waiting timings

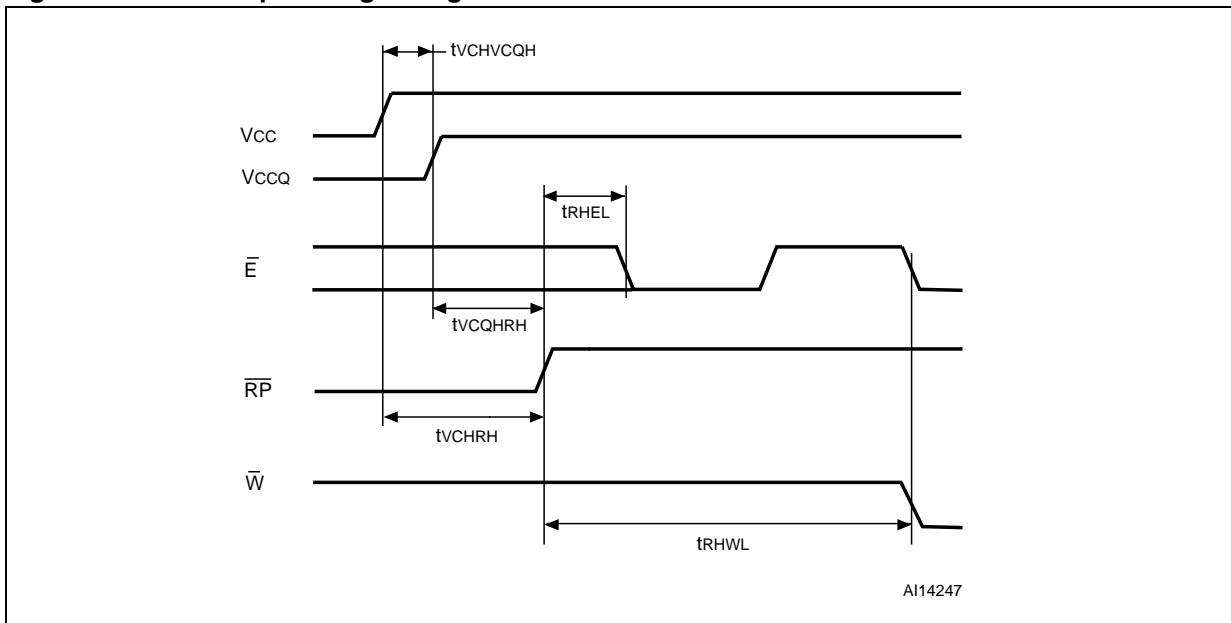

Table 24. Device capacitance⁽¹⁾

Symbol	Parameter	Test condition	Min	Max	Unit
C _{IN}	Input capacitance	V _{IN} = 0 V		6	pF
C _{OUT}	Output capacitance	V _{OUT} = 0 V		12	pF

1. Sampled only, not 100% tested.

Table 25. DC characteristics

Symbol	Parameter	Test condition	Min	Typ	Max	Unit
I _{LI} ⁽¹⁾	Input leakage current	0 V ≤ V _{IN} ≤ V _{CC}			±1	μA
I _{LO}	Output leakage current	0 V ≤ V _{OUT} ≤ V _{CC}			±1	μA
I _{CC1}	Read current	Random Read	$\bar{E} = V_{IL}, \bar{G} = V_{IH},$ f = 6 MHz		10	mA
		Page Read	$\bar{E} = V_{IL}, \bar{G} = V_{IH},$ f = 10 MHz		15	mA
I _{CC2}	Supply current (Standby)	$\bar{E} = V_{CCQ} \pm 0.2 V,$ $\overline{RP} = V_{CCQ} \pm 0.2 V$			100	μA
I _{CC3} ⁽²⁾	Supply current (Program/Erase)	Program/Erase controller active	$V_{PP}/\overline{WP} =$ V _{IL} or V _{IH}		20	mA
			$V_{PP}/\overline{WP} = V_{PPH}$		20	mA
I _{PP1}	Program current (Program)	Read or Standby	$V_{PP}/\overline{WP} \leq V_{CC}$	1	5	μA
I _{PP2}		Reset	$\overline{RP} = V_{SS} \pm 0.2 V$	1	5	μA
I _{PP3}		Program operation ongoing	$V_{PP}/\overline{WP} = 12 V \pm 5\%$	1	10	mA
	$V_{PP}/\overline{WP} = V_{CC}$		1	5	μA	
I _{PP4}	Program current (Erase)	Erase operation ongoing	$V_{PP}/\overline{WP} = 12 V \pm 5\%$	3	10	mA
			$V_{PP}/\overline{WP} = V_{CC}$	1	5	μA
V _{IL}	Input Low voltage	V _{CC} ≥ 2.7 V	-0.5		0.3V _{CCQ}	V
V _{IH}	Input High voltage	V _{CC} ≥ 2.7 V	0.7V _{CCQ}		V _{CCQ} +0.4	V
V _{OL}	Output Low voltage	I _{OL} = 100 μA, V _{CC} = V _{CC(min)} , V _{CCQ} = V _{CCQ(min)}			0.15V _{CCQ}	V
V _{OH}	Output High voltage	I _{OH} = 100 μA, V _{CC} = V _{CC(min)} , V _{CCQ} = V _{CCQ(min)}	0.85V _{CCQ}			V
V _{ID}	Identification voltage		11.5		12.5	V
V _{PPH}	Voltage for V _{PP} / \overline{WP} Program acceleration		11.4		12.6	V
V _{LKO} ⁽²⁾	Program/Erase lockout supply voltage		2.3		2.5	V

1. The maximum input leakage current is ±5 μA on the V_{PP}/ \overline{WP} pin.

2. Sampled only, not 100% tested.

Figure 13. Random Read AC waveforms (8-bit mode)

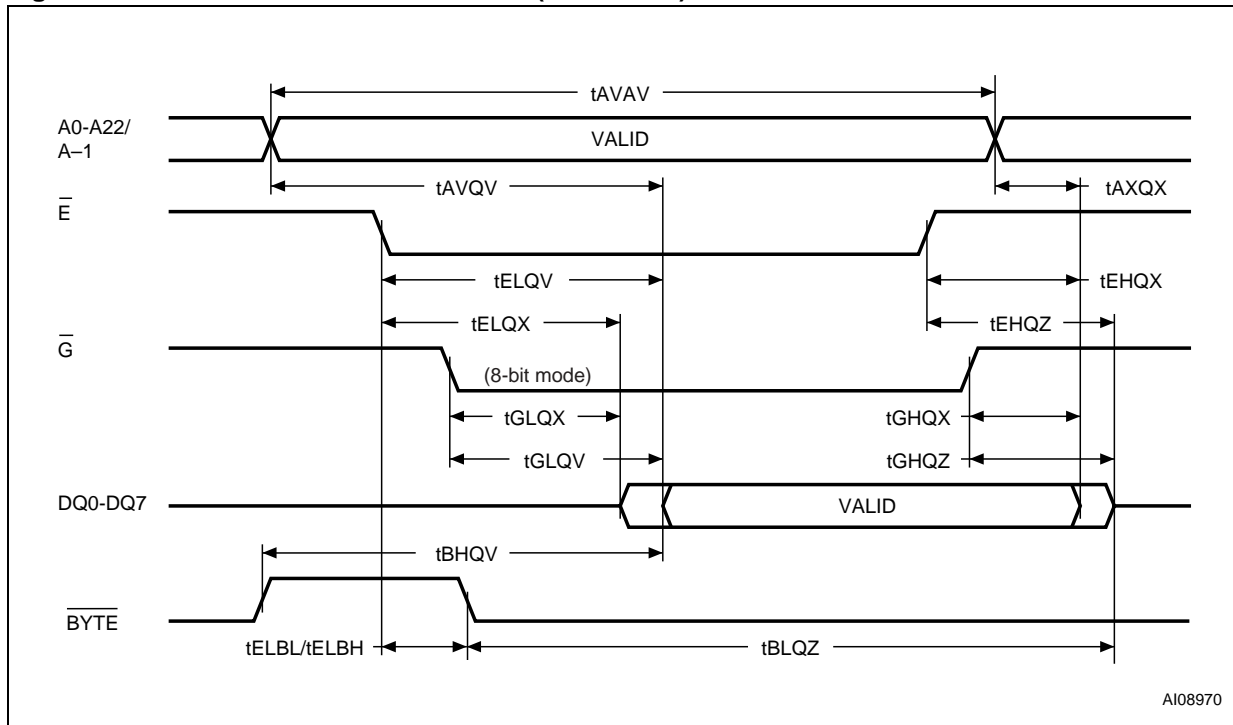

A108970

Figure 14. Random Read AC waveforms (16-bit mode)

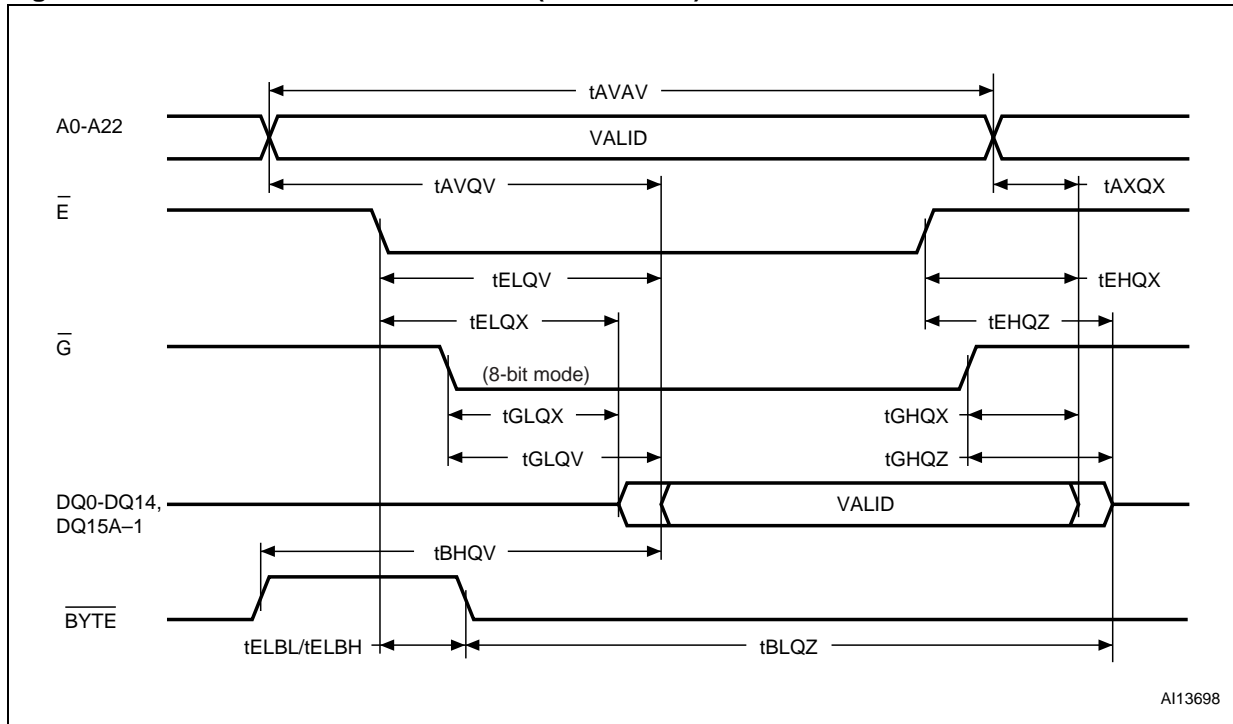

A113698

Figure 15. Page Read AC waveforms (16-bit mode)

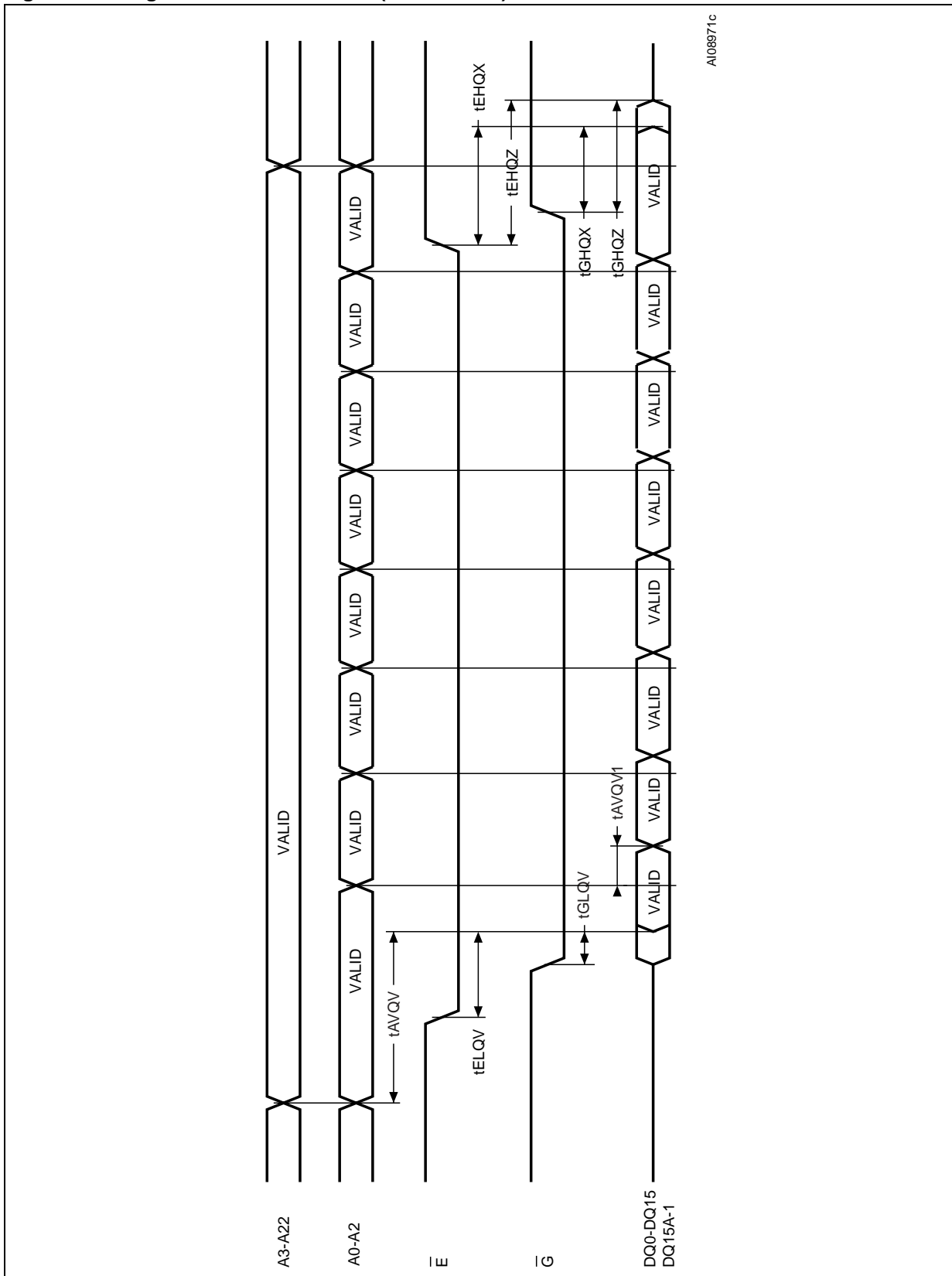

Table 26. Read AC characteristics

Symbol	Alt.	Parameter	Test condition		M29W128GH, M29W128GL			Unit
					60 ns ⁽¹⁾ V _{CCQ} =V _{CC}	70 ns V _{CCQ} =V _{CC}	80 ns V _{CCQ} =1.65 V to V _{CC}	
t _{AVAV}	t _{RC}	Address Valid to Next Address Valid	$\bar{E} = V_{IL}$, $\bar{G} = V_{IL}$	Min	60	70	80	ns
t _{AVQV}	t _{ACC}	Address Valid to Output Valid	$\bar{E} = V_{IL}$, $\bar{G} = V_{IL}$	Max	60	70	80	ns
t _{AVQV1}	t _{PAGE}	Address Valid to Output Valid (Page)	$\bar{E} = V_{IL}$, $\bar{G} = V_{IL}$	Max	25	25	30	ns
t _{ELQX} ⁽²⁾	t _{LZ}	Chip Enable Low to Output Transition	$\bar{G} = V_{IL}$	Min	0	0	0	ns
t _{ELQV}	t _E	Chip Enable Low to Output Valid	$\bar{G} = V_{IL}$	Max	60	70	80	ns
t _{GLQX} ⁽²⁾	t _{OLZ}	Output Enable Low to Output Transition	$\bar{E} = V_{IL}$	Min	0	0	0	ns
t _{GLQV}	t _{OE}	Output Enable Low to Output Valid	$\bar{E} = V_{IL}$	Max	25	25	30	ns
t _{EHQZ} ⁽²⁾	t _{HZ}	Chip Enable High to Output Hi-Z	$\bar{G} = V_{IL}$	Max	20	20	30	ns
t _{GHQZ} ⁽²⁾	t _{DF}	Output Enable High to Output Hi-Z	$\bar{E} = V_{IL}$	Max	20	20	20	ns
t _{EHQX} t _{GHQX} t _{AXQX}	t _{OH}	Chip Enable, Output Enable or Address Transition to Output Transition		Min	0	0	0	ns
t _{ELBL} t _{ELBH}	t _{ELFL} t _{ELFH}	Chip Enable to $\overline{\text{BYTE}}$ Low or High		Max	5	5	5	ns
t _{BLQZ}	t _{FLQZ}	$\overline{\text{BYTE}}$ Low to Output Hi-Z		Max	25	25	25	ns
t _{BHQV}	t _{FHQV}	$\overline{\text{BYTE}}$ High to Output Valid		Max	30	30	30	ns

1. Only available upon customer request.

2. Sampled only, not 100% tested.

Figure 16. Write Enable Controlled Program waveforms (8-bit mode)

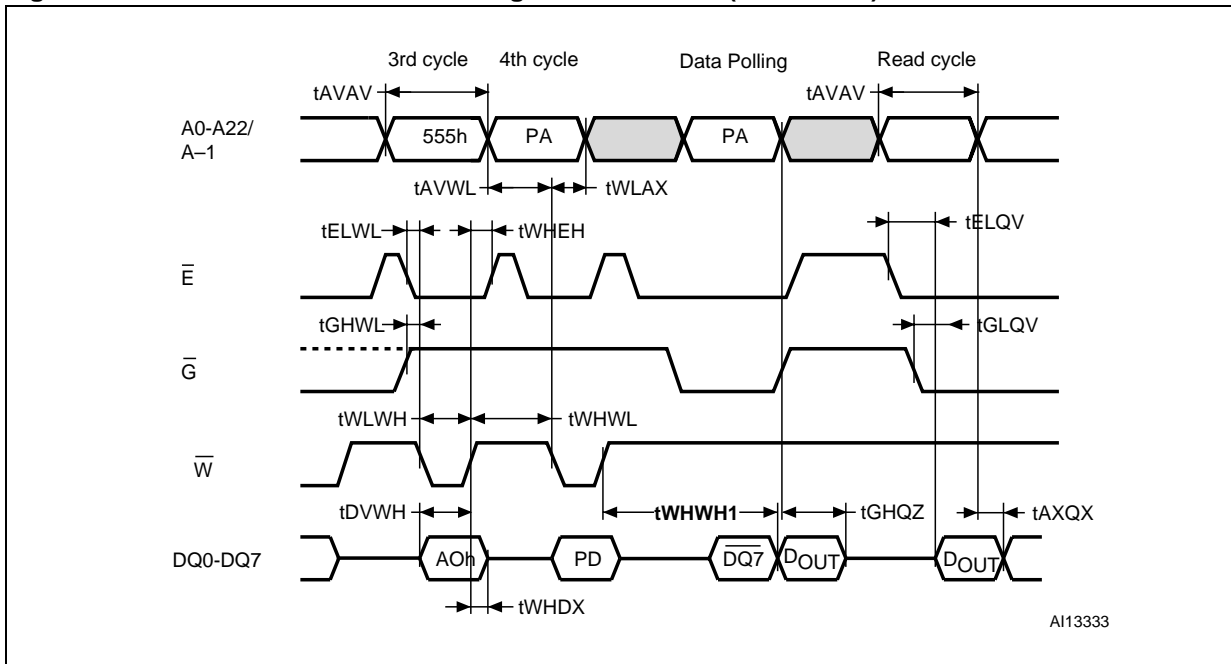

1. Only the third and fourth cycles of the Program command are represented. The Program command is followed by the check of Status Register Data Polling bit and by a read operation that outputs the data, DOUT, programmed by the previous Program command.
2. PA is the address of the memory location to be programmed. PD is the data to be programmed.
3. DQ7 is the complement of the data bit being programmed to DQ7 (see [Section 7.2.1: Data Polling bit \(DQ7\)](#)).
4. See [Table 27: Write AC characteristics, Write Enable Controlled](#), [Table 28: Write AC characteristics, Chip Enable Controlled](#) and [Table 26: Read AC characteristics](#) for details on the timings.

Figure 17. Write Enable Controlled Program waveforms (16-bit mode)

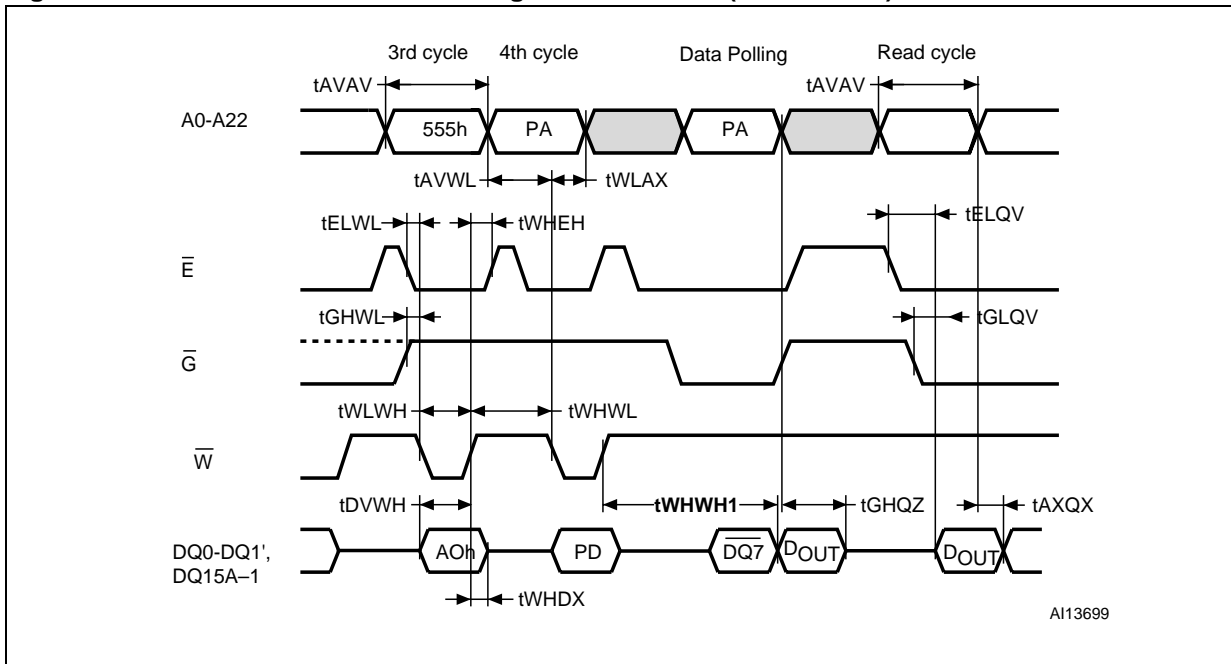

1. Only the third and fourth cycles of the Program command are represented. The Program command is followed by the check of Status Register Data Polling bit and by a read operation that outputs the data, DOUT, programmed by the previous Program command.
2. PA is the address of the memory location to be programmed. PD is the data to be programmed.
3. DQ7 is the complement of the data bit being programmed to DQ7 (see [Section 7.2.1: Data Polling bit \(DQ7\)](#)).
4. See [Table 27: Write AC characteristics, Write Enable Controlled](#), [Table 28: Write AC characteristics, Chip Enable Controlled](#) and [Table 26: Read AC characteristics](#) for details on the timings.

Table 27. Write AC characteristics, Write Enable Controlled

Symbol	Alt	Parameter		M29W128GH, M29W128GL			Unit
				60 ns ⁽¹⁾	70 ns	80 ns	
t_{AVAV}	t_{WC}	Address Valid to Next Address Valid	Min	60	70	80	ns
t_{ELWL}	t_{CS}	Chip Enable Low to Write Enable Low	Min	0	0	0	ns
t_{WLWH}	t_{WP}	Write Enable Low to Write Enable High	Min	35	35	35	ns
t_{DVWH}	t_{DS}	Input Valid to Write Enable High	Min	45	45	45	ns
t_{WHDX}	t_{DH}	Write Enable High to Input Transition	Min	0	0	0	ns
t_{WHEH}	t_{CH}	Write Enable High to Chip Enable High	Min	0	0	0	ns
t_{WHWL}	t_{WPH}	Write Enable High to Write Enable Low	Min	30	30	30	ns
t_{AVWL}	t_{AS}	Address Valid to Write Enable Low	Min	0	0	0	ns
t_{WLAX}	t_{AH}	Write Enable Low to Address Transition	Min	45	45	45	ns
t_{GHWL}		Output Enable High to Write Enable Low	Min	0	0	0	ns
t_{WHGL}	t_{OEH}	Write Enable High to Output Enable Low	Min	0	0	0	ns
$t_{WHRL}^{(2)}$	t_{BUSY}	Program/Erase Valid to \overline{RB} Low	Max	30	30	30	ns
t_{VCHEL}	t_{VCS}	V_{CC} High to Chip Enable Low	Min	50	50	50	μ s

1. Only available upon customer request.
2. Sampled only, not 100% tested.

Figure 18. Chip Enable Controlled Program waveforms (8-bit mode)

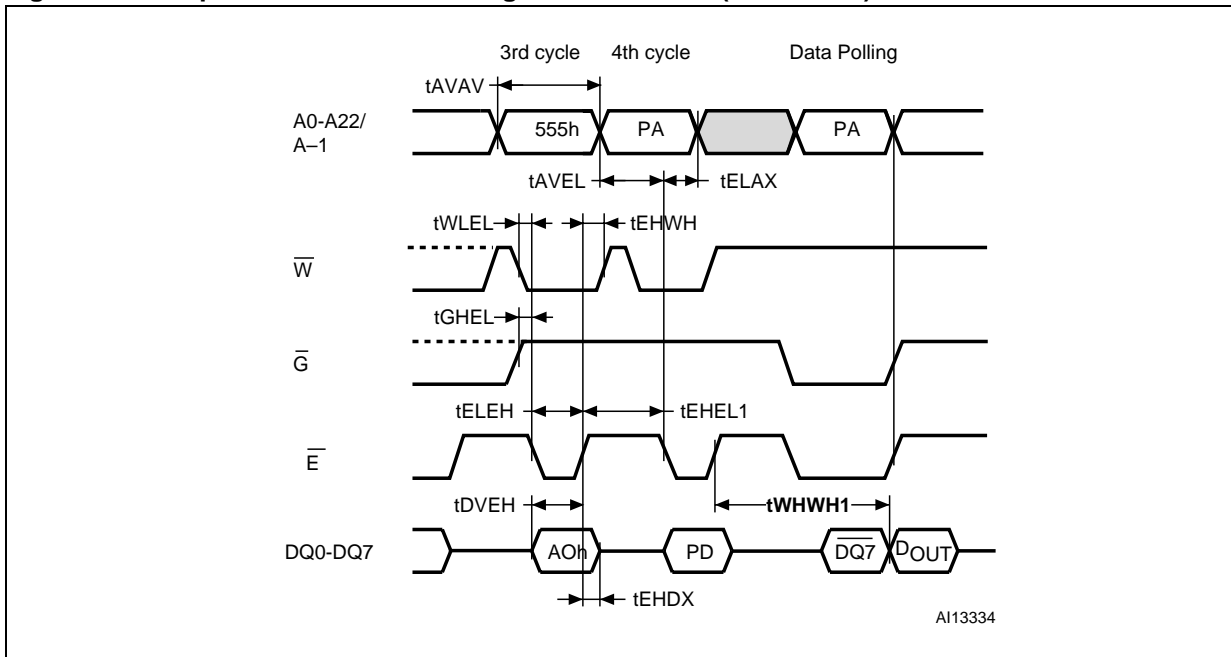

1. Only the third and fourth cycles of the Program command are represented. The Program command is followed by the check of Status Register Data Polling bit.
2. PA is the address of the memory location to be programmed. PD is the data to be programmed.
3. DQ7 is the complement of the data bit being programmed to DQ7 (see [Section 7.2.1: Data Polling bit \(DQ7\)](#)).
4. See [Table 27: Write AC characteristics, Write Enable Controlled](#), [Table 28: Write AC characteristics, Chip Enable Controlled](#) and [Table 26: Read AC characteristics](#) for details on the timings.

Figure 19. Chip Enable Controlled Program waveforms (16-bit mode)

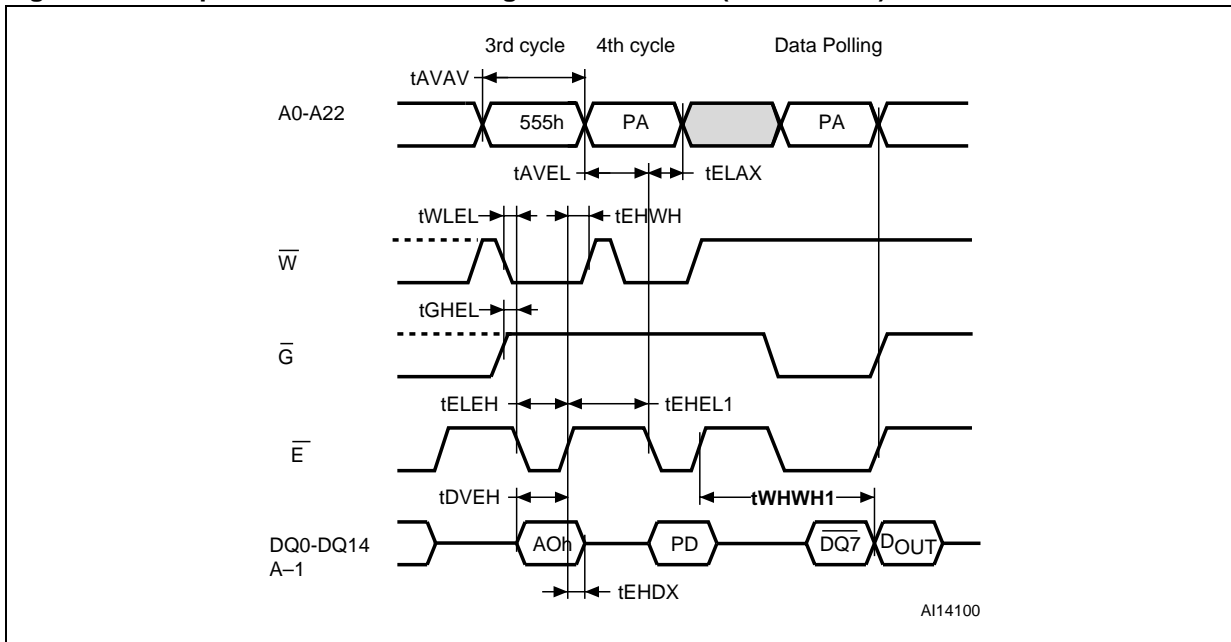

1. Only the third and fourth cycles of the Program command are represented. The Program command is followed by the check of Status Register Data Polling bit.
2. PA is the address of the memory location to be programmed. PD is the data to be programmed.
3. DQ7 is the complement of the data bit being programmed to DQ7 (see [Section 7.2.1: Data Polling bit \(DQ7\)](#)).
4. See [Table 27: Write AC characteristics, Write Enable Controlled](#), [Table 28: Write AC characteristics, Chip Enable Controlled](#) and [Table 26: Read AC characteristics](#) for details on the timings.

Figure 20. Chip/Block Erase waveforms (8-bit mode)

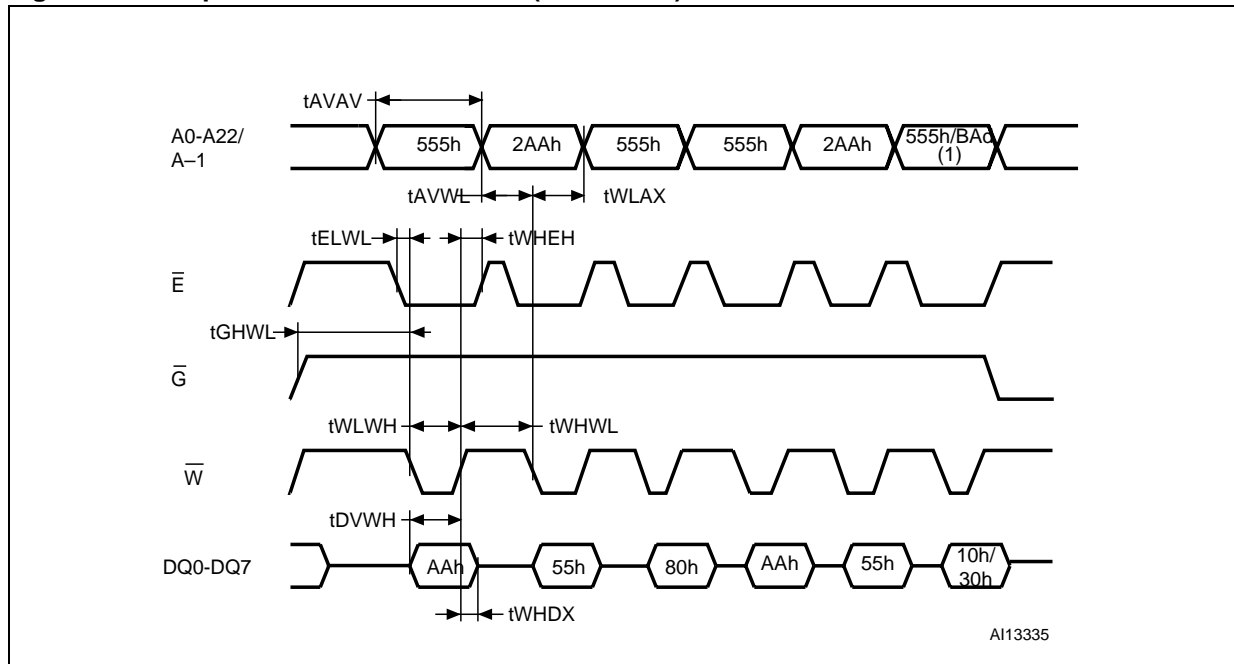

1. For a Chip Erase command, addresses and data are 555h and 10h, respectively, while they are BAd and 30h for a Block Erase command.
2. BAd is the block address.
3. See [Table 27: Write AC characteristics, Write Enable Controlled](#), [Table 28: Write AC characteristics, Chip Enable Controlled](#) and [Table 26: Read AC characteristics](#) for details on the timings.

Table 28. Write AC characteristics, Chip Enable Controlled

Symbol	Alt.	Parameter		M29W128GH, M29W128GL			Unit
				60 ns ⁽¹⁾	70 ns	80 ns	
t _{AVAV}	t _{WC}	Address Valid to Next Address Valid	Min	60	70	80	ns
t _{WLEL}	t _{WS}	Write Enable Low to Chip Enable Low	Min	0	0	0	ns
t _{ELEH}	t _{CP}	Chip Enable Low to Chip Enable High	Min	35	35	35	ns
t _{DVEH}	t _{DS}	Input Valid to Chip Enable High	Min	45	45	45	ns
t _{EHDX}	t _{DH}	Chip Enable High to Input Transition	Min	0	0	0	ns
t _{EHWH}	t _{WH}	Chip Enable High to Write Enable High	Min	0	0	0	ns
t _{EHEL}	t _{CPH}	Chip Enable High to Chip Enable Low	Min	30	30	30	ns
t _{AVEL}	t _{AS}	Address Valid to Chip Enable Low	Min	0	0	0	ns
t _{ELAX}	t _{AH}	Chip Enable Low to Address Transition	Min	45	45	45	ns
t _{GHEL}		Output Enable High Chip Enable Low	Min	0	0	0	ns

1. Only available upon customer request.

Figure 21. Reset AC waveforms (no program/erase ongoing)

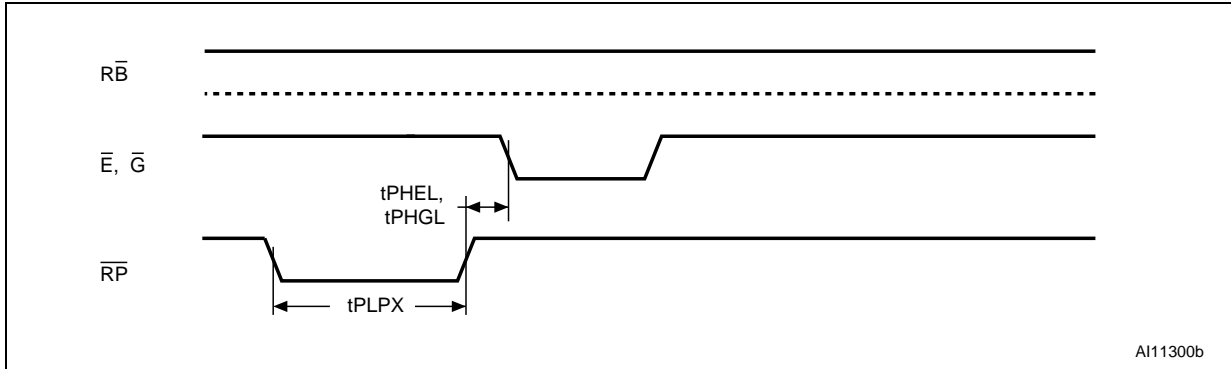

A111300b

Figure 22. Reset during program/erase operation AC waveforms

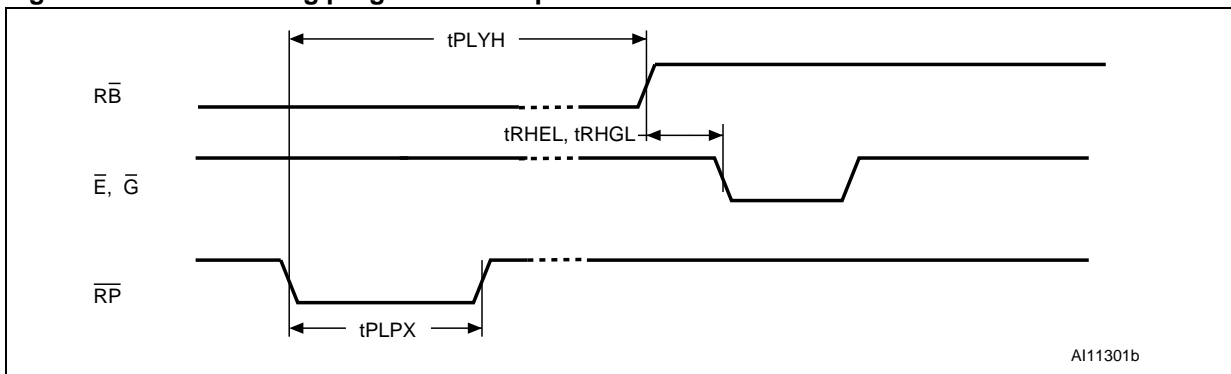

A111301b

Table 29. Reset AC characteristics

Symbol	Alt.	Parameter		M29W128GH, M29W128GL			Unit
				60 ⁽¹⁾	70	80	
$t_{PLYH}^{(2)}$	t_{READY}	\overline{RP} Low to Read mode, during Program or Erase	Max	50	50	50	μs
t_{PLPX}	t_{RP}	\overline{RP} Pulse width	Min	10	10	10	μs
$t_{PHEL}, t_{PHGL}^{(2)}$	t_{RH}	\overline{RP} High to Write Enable Low, Chip Enable Low, Output Enable Low	Min	50	50	50	ns
	t_{RPD}	\overline{RP} Low to Standby mode, during Read mode	Min	10	10	10	μs
		\overline{RP} Low to Standby mode, during Program or Erase	Min	50	50	50	μs
$t_{RHEL}, t_{RHGL}^{(2)}$	t_{RB}	\overline{RB} High to Write Enable Low, Chip Enable Low, Output Enable Low	Min	0	0	0	ns

1. Only available upon customer request.

2. Sampled only, not 100% tested.

Figure 23. Accelerated program timing waveforms

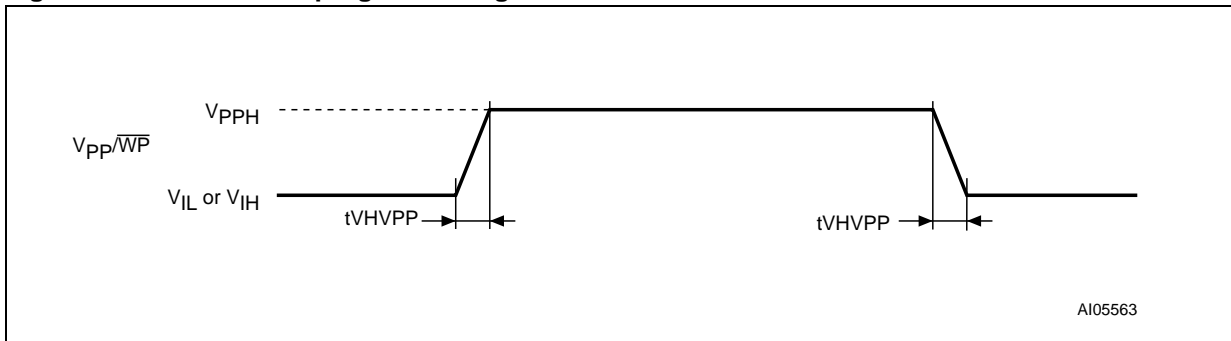
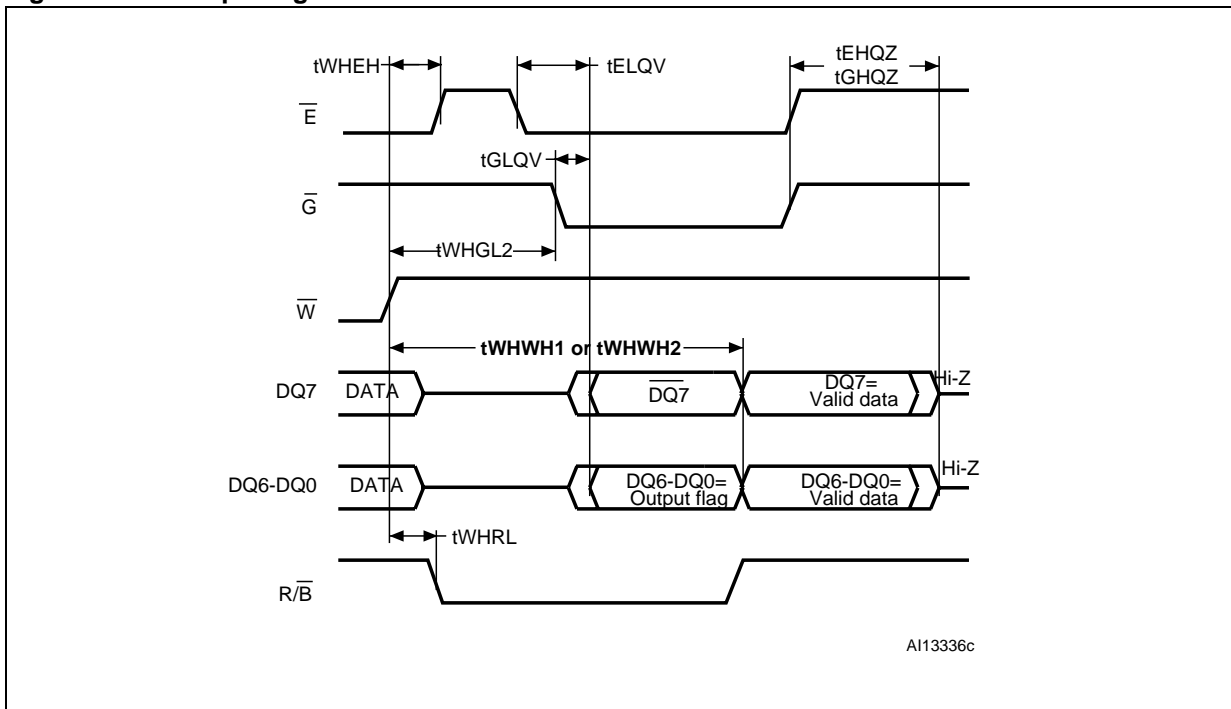
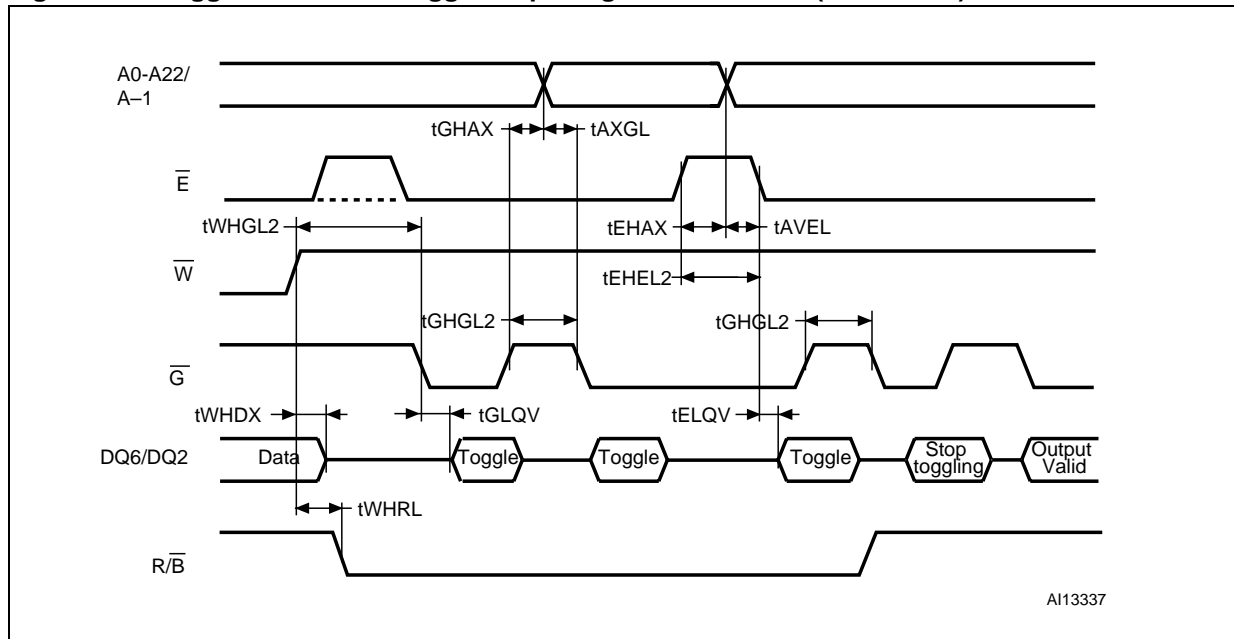

Figure 24. Data polling AC waveforms



1. DQ7 returns valid data bit when the ongoing Program or Erase command is completed.
2. See [Table 30: Accelerated Program and Data Polling/Data Toggle AC characteristics](#) and [Table 26: Read AC characteristics](#) for details on the timings.

Figure 25. Toggle/Alternative Toggle bit polling AC waveforms (8-bit mode)



1. DQ6 stops toggling when the ongoing Program or Erase command is completed. DQ2 stops toggling when the ongoing Chip Erase or Block Erase command is completed.
2. See [Table 30: Accelerated Program and Data Polling/Data Toggle AC characteristics](#) and [Table 26: Read AC characteristics](#) for details on the timings.

Table 30. Accelerated Program and Data Polling/Data Toggle AC characteristics

Symbol	Alt	Parameter		M29W128GH, M29W128GL			Unit
				60 ⁽¹⁾	70	80	
t _{VHPP}		V _{PP} / \overline{WP} raising and falling time	Min	250	250	250	ns
t _{AXGL}	t _{ASO}	Address setup time to Output Enable Low during Toggle bit polling	Min	10	10	10	ns
t _{GHAX} , t _{EHAX}	t _{AHT}	Address hold time from Output Enable during Toggle bit polling	Min	10	10	10	ns
t _{EHEL2}	t _{EPH}	Chip Enable High during Toggle bit polling	Min	10	10	10	ns
t _{WHGL2} , t _{GHGL2}	t _{OEH}	Output Hold time during Data and Toggle bit polling	Min	20	20	20	ns
t _{WHRL}	t _{BUSY}	Program/Erase Valid to \overline{RB} Low	Max	30	30	30	ns

1. Only available upon customer request.

10 Package mechanical

In order to meet environmental requirements, ST offers these devices in ECOPACK® packages. ECOPACK® packages are lead-free. The category of second level interconnect is marked on the package and on the inner box label, in compliance with JEDEC Standard JESD97. The maximum ratings related to soldering conditions are also marked on the inner box label. ECOPACK is an ST trademark. ECOPACK specifications are available at: www.st.com.

Figure 26. TSOP56 – 56 lead plastic thin small outline, 14 x 20 mm, package outline

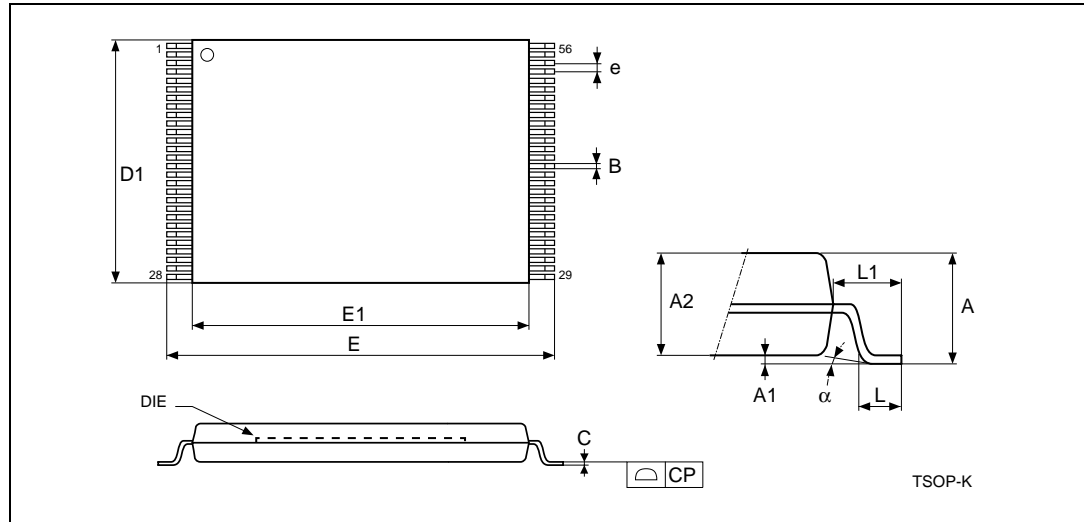

1. Drawing is not to scale.

Table 31. TSOP56 – 56 lead plastic thin small outline, 14 x 20 mm, package mechanical data

Symbol	Millimeters			Inches		
	Typ	Min	Max	Typ	Min	Max
A			1.20			0.047
A1	0.10	0.05	0.15	0.004	0.002	0.006
A2	1.00	0.95	1.05	0.039	0.037	0.041
B	0.22	0.17	0.27	0.009	0.007	0.011
C		0.10	0.21		0.004	0.008
CP			0.10			0.004
D1	14.00	13.90	14.10	0.551	0.547	0.555
E	20.00	19.80	20.20	0.787	0.780	0.795
E1	18.40	18.30	18.50	0.724	0.720	0.728
e	0.50	–	–	0.020	–	–
L	0.60	0.50	0.70	0.024	0.020	0.028
alpha	3	0	5	3	0	5

Figure 27. TBGA64 10 x 13 mm - 8 x 8 active ball array, 1 mm pitch, package outline

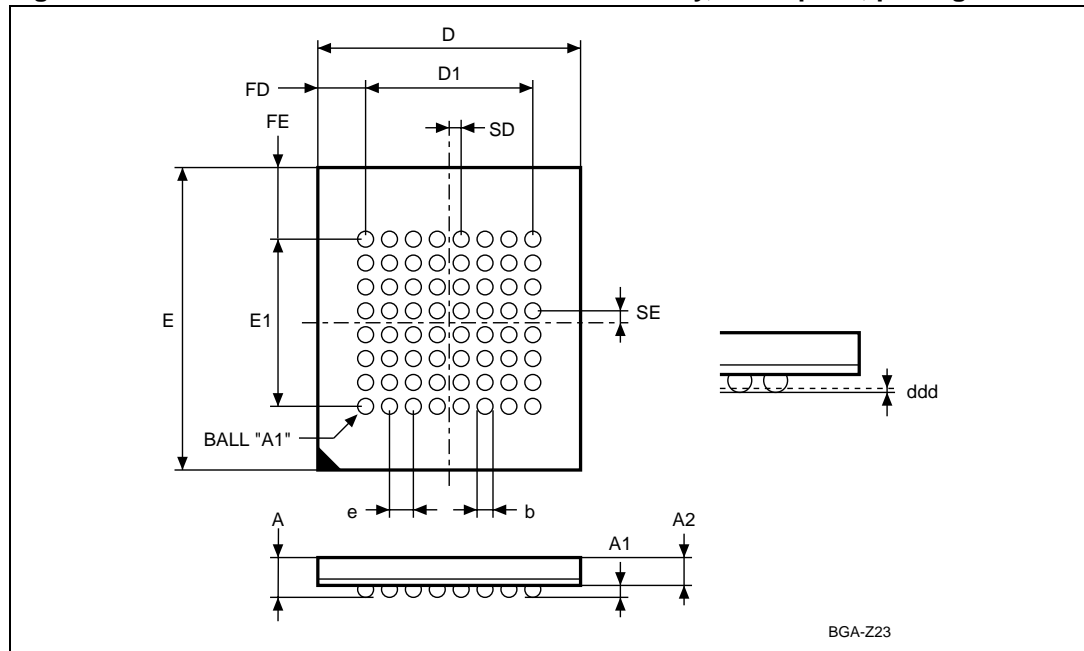

1. Drawing is not to scale.

Table 32. TBGA64 10 x 13 mm - 8 x 8 active ball array, 1 mm pitch, package mechanical data

Symbol	millimeters			inches		
	Typ	Min	Max	Typ	Min	Max
A			1.20			0.047
A1	0.30	0.20	0.35	0.012	0.008	0.014
A2	0.80			0.031		
b		0.35	0.50		0.014	0.020
D	10.00	9.90	10.10	0.394	0.390	0.398
D1	7.000	-	-	0.276	-	-
ddd			0.10			0.004
e	1.00	-	-	0.039	-	-
E	13.00	12.90	13.10	0.512	0.508	0.516
E1	7.00	-	-	0.276	-	-
FD	1.50	-	-	0.059	-	-
FE	3.00	-	-	0.118	-	-
SD	0.50	-	-	0.020	-	-
SE	0.50	-	-	0.020	-	-

11 Ordering information

Table 33. Ordering information scheme

Example:	M29W128GH	70	N	6	F
Device type					
M29					
Operating voltage					
W = V _{CC} = 2.7 to 3.6 V					
Device function					
128GH = 128 Mbit (x 8/x 16), page, uniform block, Flash memory, highest block protected by V _{PP} /WP					
128GL = 128 Mbit (x 8/x 16), page, uniform block, Flash memory, lowest block protected by V _{PP} /WP					
Speed					
70 = 70 ns (80 ns if V _{CCQ} = 1.65 V to V _{CC})					
60 = 60 ns (80 ns if V _{CCQ} = 1.65 V to V _{CC}) ⁽¹⁾					
Package					
N = TSOP56: 14 x 20 mm					
ZA = TBGA64: 10 x 13 mm, 1 mm pitch					
Temperature range					
6 = -40 to 85 °C					
Option					
E = ECOPACK package, standard packing					
F = ECOPACK package, tape & reel packing					

1. Only available upon customer request.

Note: This product is also available with the extended memory block factory locked. For further details and ordering information contact your nearest ST sales office.

Devices are shipped from the factory with the memory content bits erased to '1'. For a list of available options (speed, package, etc.) or for further information on any aspect of this device, please contact your nearest ST Sales Office.

Appendix A Block addresses and read/modify protection groups

Table 34. Block addresses

Block	Protection group	Block size (Kbytes/ Kwords)	8-bit address range (in hexadecimal)	16-bit address range (in hexadecimal)
0	Protection group	128/64	0000000–001FFFF	0000000–000FFFF
1	Protection group	128/64	0020000–003FFFF	0010000–001FFFF
2	Protection group	128/64	0040000–005FFFF	0020000–002FFFF
3	Protection group	128/64	0060000–007FFFF	0030000–003FFFF
4	Protection group	128/64	0080000–009FFFF	0040000–004FFFF
5	Protection group	128/64	00A0000–00BFFFF	0050000–005FFFF
6	Protection group	128/64	00C0000–00DFFFF	0060000–006FFFF
7	Protection group	128/64	00E0000–00FFFFFF	0070000–007FFFF
8	Protection group	128/64	0100000–011FFFF	0080000–008FFFF
9	Protection group	128/64	0120000–013FFFF	0090000–009FFFF
10	Protection group	128/64	0140000–015FFFF	00A0000–00AFFFF
11	Protection group	128/64	0160000–017FFFF	00B0000–00BFFFF
12	Protection group	128/64	0180000–019FFFF	00C0000–00CFFFF
13	Protection group	128/64	01A0000–01BFFFF	00D0000–00DFFFF
14	Protection group	128/64	01C0000–01DFFFF	00E0000–00EFFFF
15	Protection group	128/64	01E0000–01FFFFFF	00F0000–00FFFFFF
16	Protection group	128/64	0200000–021FFFF	0100000–010FFFF
17	Protection group	128/64	0220000–023FFFF	0110000–011FFFF
18	Protection group	128/64	0240000–025FFFF	0120000–012FFFF
19	Protection group	128/64	0260000–027FFFF	0130000–013FFFF
20	Protection group	128/64	0280000–029FFFF	0140000–014FFFF
21	Protection group	128/64	02A0000–02BFFFF	0150000–015FFFF
22	Protection group	128/64	02C0000–02DFFFF	0160000–016FFFF
23	Protection group	128/64	02E0000–02FFFFFF	0170000–017FFFF
24	Protection group	128/64	0300000–031FFFF	0180000–018FFFF
25	Protection group	128/64	0320000–033FFFF	0190000–019FFFF
26	Protection group	128/64	0340000–035FFFF	01A0000–01AFFFF
27	Protection group	128/64	0360000–037FFFF	01B0000–01BFFFF
28	Protection group	128/64	0380000–039FFFF	01C0000–01CFFFF
29	Protection group	128/64	03A0000–03BFFFF	01D0000–01DFFFF

Table 34. Block addresses (continued)

Block	Protection group	Block size (Kbytes/ Kwords)	8-bit address range (in hexadecimal)	16-bit address range (in hexadecimal)
30	Protection group	128/64	03C0000–03DFFFF	01E0000–01EFFFF
31	Protection group	128/64	03E0000–03FFFFFF	01F0000–01FFFFFF
32	Protection group	128/64	0400000–041FFFF	0200000–020FFFF
33	Protection group	128/64	0420000–043FFFF	0210000–021FFFF
34	Protection group	128/64	0440000–045FFFF	0220000–022FFFF
35	Protection group	128/64	0460000–047FFFF	0230000–023FFFF
36	Protection group	128/64	0480000–049FFFF	0240000–024FFFF
37	Protection group	128/64	04A0000–04BFFFF	0250000–025FFFF
38	Protection group	128/64	04C0000–04DFFFF	0260000–026FFFF
39	Protection group	128/64	04E0000–04FFFFFF	0270000–027FFFF
40	Protection group	128/64	0500000–051FFFF	0280000–028FFFF
41	Protection group	128/64	0520000–053FFFF	0290000–029FFFF
42	Protection group	128/64	0540000–055FFFF	02A0000–02AFFFF
43	Protection group	128/64	0560000–057FFFF	02B0000–02BFFFF
44	Protection group	128/64	0580000–059FFFF	02C0000–02CFFFF
45	Protection group	128/64	05A0000–05BFFFF	02D0000–02DFFFF
46	Protection group	128/64	05C0000–05DFFFF	02E0000–02EFFFF
47	Protection group	128/64	05E0000–05FFFFFF	02F0000–02FFFFFF
48	Protection group	128/64	0600000–061FFFF	0300000–030FFFF
49	Protection group	128/64	0620000–063FFFF	0310000–031FFFF
50	Protection group	128/64	0640000–065FFFF	0320000–032FFFF
51	Protection group	128/64	0660000–067FFFF	0330000–033FFFF
52	Protection group	128/64	0680000–069FFFF	0340000–034FFFF
53	Protection group	128/64	06A0000–06BFFFF	0350000–035FFFF
54	Protection group	128/64	06C0000–06DFFFF	0360000–036FFFF
55	Protection group	128/64	06E0000–06FFFFFF	0370000–037FFFF
56	Protection group	128/64	0700000–071FFFF	0380000–038FFFF
57	Protection group	128/64	0720000–073FFFF	0390000–039FFFF
58	Protection group	128/64	0740000–075FFFF	03A0000–03AFFFF
59	Protection group	128/64	0760000–077FFFF	03B0000–03BFFFF
60	Protection group	128/64	0780000–079FFFF	03C0000–03CFFFF
61	Protection group	128/64	07A0000–07BFFFF	03D0000–03DFFFF
62	Protection group	128/64	07C0000–07DFFFF	03E0000–03EFFFF

Table 34. Block addresses (continued)

Block	Protection group	Block size (Kbytes/ Kwords)	8-bit address range (in hexadecimal)	16-bit address range (in hexadecimal)
63	Protection group	128/64	07E0000–07FFFFFF	03F0000–03FFFFFF
64	Protection group	128/64	0800000–081FFFF	0400000–040FFFF
65	Protection group	128/64	0820000–083FFFF	0410000–041FFFF
66	Protection group	128/64	0840000–085FFFF	0420000–042FFFF
67	Protection group	128/64	0860000–087FFFF	0430000–043FFFF
68	Protection group	128/64	0880000–089FFFF	0440000–044FFFF
69	Protection group	128/64	08A0000–08BFFFF	0450000–045FFFF
70	Protection group	128/64	08C0000–08DFFFF	0460000–046FFFF
71	Protection group	128/64	08E0000–08FFFFFF	0470000–047FFFF
72	Protection group	128/64	0900000–091FFFF	0480000–048FFFF
73	Protection group	128/64	0920000–093FFFF	0490000–049FFFF
74	Protection group	128/64	0940000–095FFFF	04A0000–04AFFFF
75	Protection group	128/64	0960000–097FFFF	04B0000–04BFFFF
76	Protection group	128/64	0980000–099FFFF	04C0000–04CFFFF
77	Protection group	128/64	09A0000–09BFFFF	04D0000–04DFFFF
78	Protection group	128/64	09C0000–09DFFFF	04E0000–04EFFFF
79	Protection group	128/64	09E0000–09FFFFFF	04F0000–04FFFFFF
80	Protection group	128/64	0A00000–0A1FFFF	0500000–050FFFF
81	Protection group	128/64	0A20000–0A3FFFF	0510000–051FFFF
82	Protection group	128/64	0A40000–0A5FFFF	0520000–052FFFF
83	Protection group	128/64	0A60000–0A7FFFF	0530000–053FFFF
84	Protection group	128/64	0A80000–0A9FFFF	0540000–054FFFF
85	Protection group	128/64	0AA0000–0ABFFFF	0550000–055FFFF
86	Protection group	128/64	0AC0000–0ADFFFF	0560000–056FFFF
87	Protection group	128/64	0AE0000–0AFFFFF	0570000–057FFFF
88	Protection group	128/64	0B00000–0B1FFFF	0580000–058FFFF
89	Protection group	128/64	0B20000–0B3FFFF	0590000–059FFFF
90	Protection group	128/64	0B40000–0B5FFFF	05A0000–05AFFFF
91	Protection group	128/64	0B60000–0B7FFFF	05B0000–05BFFFF
92	Protection group	128/64	0B80000–0B9FFFF	05C0000–05CFFFF
93	Protection group	128/64	0BA0000–0BBFFFF	05D0000–05DFFFF
94	Protection group	128/64	0BC0000–0BDFFFF	05E0000–05EFFFF
95	Protection group	128/64	0BE0000–0BFFFFFF	05F0000–05FFFFFF

Table 34. Block addresses (continued)

Block	Protection group	Block size (Kbytes/ Kwords)	8-bit address range (in hexadecimal)	16-bit address range (in hexadecimal)
96	Protection group	128/64	0C0000–0C1FFFFF	0600000–060FFFFF
97	Protection group	128/64	0C20000–0C3FFFFF	0610000–061FFFFF
98	Protection group	128/64	0C40000–0C5FFFFF	0620000–062FFFFF
99	Protection group	128/64	0C60000–0C7FFFFF	0630000–063FFFFF
100	Protection group	128/64	0C80000–0C9FFFFF	0640000–064FFFFF
101	Protection group	128/64	0CA0000–0CBFFFFF	0650000–065FFFFF
102	Protection group	128/64	0CC0000–0CDFFFFF	0660000–066FFFFF
103	Protection group	128/64	0CE0000–0CFFFFFFF	0670000–067FFFFF
104	Protection group	128/64	0D00000–0D1FFFFF	0680000–068FFFFF
105	Protection group	128/64	0D20000–0D3FFFFF	0690000–069FFFFF
106	Protection group	128/64	0D40000–0D5FFFFF	06A0000–06AFFFFF
107	Protection group	128/64	0D60000–0D7FFFFF	06B0000–06BFFFFF
108	Protection group	128/64	0D80000–0D9FFFFF	06C0000–06CFFFFF
109	Protection group	128/64	0DA0000–0DBFFFFF	06D0000–06DFFFFF
110	Protection group	128/64	0DC0000–0DDFFFFF	06E0000–06EFFFFF
111	Protection group	128/64	0DE0000–0DFFFFFFF	06F0000–06FFFFFFF
112	Protection group	128/64	0E00000–0E1FFFFF	0700000–070FFFFF
113	Protection group	128/64	0E20000–0E3FFFFF	0710000–071FFFFF
114	Protection group	128/64	0E40000–0E5FFFFF	0720000–072FFFFF
115	Protection group	128/64	0E60000–0E7FFFFF	0730000–073FFFFF
116	Protection group	128/64	0E80000–0E9FFFFF	0740000–074FFFFF
117	Protection group	128/64	0EA0000–0EBFFFFF	0750000–075FFFFF
118	Protection group	128/64	0EC0000–0EDFFFFF	0760000–076FFFFF
119	Protection group	128/64	0EE0000–0EFFFFFFF	0770000–077FFFFF
120	Protection group	128/64	0F00000–0F1FFFFF	0780000–078FFFFF
121	Protection group	128/64	0F20000–0F3FFFFF	0790000–079FFFFF
122	Protection group	128/64	0F40000–0F5FFFFF	07A0000–07AFFFFF
123	Protection group	128/64	0F60000–0F7FFFFF	07B0000–07BFFFFF
124	Protection group	128/64	0F80000–0F9FFFFF	07C0000–07CFFFFF
125	Protection group	128/64	0FA0000–0FBFFFFF	07D0000–07DFFFFF
126	Protection group	128/64	0FC0000–0FDFFFFF	07E0000–07EFFFFF
127	Protection group	128/64	0FE0000–0FFFFFFF	07F0000–07FFFFFFF

Appendix B Common Flash interface (CFI)

The common Flash interface is a JEDEC approved, standardized data structure that can be read from the Flash memory device. It allows a system software to query the device to determine various electrical and timing parameters, density information and functions supported by the memory. The system can interface easily with the device, enabling the software to upgrade itself when necessary.

When the Read CFI Query command is issued, the memory enters Read CFI Query mode and read operations output the CFI data. [Table 35](#), [Table 36](#), [Table 37](#), [Table 38](#), [Table 39](#) and [Table 40](#) show the addresses (A-1, A0-A7) used to retrieve the data. The CFI data structure also contains a security area where a 64 bit unique security number is written (see [Table 40: Security code area](#)). This area can be accessed only in Read mode by the final user. It is impossible to change the security number after it has been written by ST.

Table 35. Query structure overview⁽¹⁾

Address		Sub-section name	Description
x 16	x 8		
10h	20h	CFI query identification string	Command set ID and algorithm data offset
1Bh	36h	System interface information	Device timing & voltage information
27h	4Eh	Device geometry definition	Flash device layout
40h	80h	Primary algorithm-specific extended query table	Additional information specific to the primary algorithm (optional)
61h	C2h	Security code area	64 bit unique device number

1. Query data are always presented on the lowest order data outputs.

Table 36. CFI query identification string⁽¹⁾

Address		Data	Description	Value
x 16	x 8			
10h	20h	0051h	Query Unique ASCII String 'QRY'	'Q'
11h	22h	0052h		'R'
12h	24h	0059h		'Y'
13h	26h	0002h	Primary algorithm command set and control interface ID code 16 bit ID code defining a specific algorithm	AMD compatible
14h	28h	0000h		
15h	2Ah	0040h	Address for primary algorithm extended query table (see Table 39)	P = 40h
16h	2Ch	0000h		
17h	2Eh	0000h	Alternate vendor command set and control interface ID code second vendor - specified algorithm supported	NA
18h	30h	0000h		
19h	32h	0000h	Address for alternate algorithm extended query table	NA
1Ah	34h	0000h		

1. Query data are always presented on the lowest order data outputs (DQ7-DQ0) only. DQ8-DQ15 are '0'.

Table 37. CFI query system interface information⁽¹⁾

Address		Data	Description	Value
x 16	x 8			
1Bh	36h	0027h	V _{CC} logic supply minimum Program/Erase voltage bit 7 to 4BCD value in volts bit 3 to 0BCD value in 100 mV	2.7 V
1Ch	38h	0036h	V _{CC} logic supply maximum Program/Erase voltage bit 7 to 4BCD value in volts bit 3 to 0BCD value in 100 mV	3.6 V
1Dh	3Ah	00B5h	V _{PPH} [programming] supply minimum Program/Erase voltage bit 7 to 4HEX value in volts bit 3 to 0BCD value in 100 mV	11.5 V
1Eh	3Ch	00C5h	V _{PPH} [programming] supply maximum Program/Erase voltage bit 7 to 4HEX value in volts bit 3 to 0BCD value in 10 mV	12.5 V
1Fh	3Eh	0004h	Typical timeout for single byte/word program = 2 ⁿ μs	16 μs
20h	40h	0004h	Typical timeout for minimum size write buffer program = 2 ⁿ μs	16 μs
21h	42h	0009h	Typical timeout for individual block erase = 2 ⁿ ms	0.5 s
22h	44h	0010h	Typical timeout for full Chip Erase = 2 ⁿ ms	40 s
23h	46h	0004h	Maximum timeout for byte/word program = 2 ⁿ times typical	200 μs
24h	48h	0002h	Maximum timeout for write buffer program = 2 ⁿ times typical	200 μs
25h	4Ah	0003h	Maximum timeout per individual block erase = 2 ⁿ times typical	2.3 s
26h	4Ch	0004h	Maximum timeout for Chip Erase = 2 ⁿ times typical	400 s

1. The values given in the above table are valid for both packages.

Table 38. Device geometry definition

Address		Data	Description	Value
x 16	x 8			
27h	4Eh	0018h	Device size = 2^n in number of bytes	16 Mbytes
28h 29h	50h 52h	0002h 0000h	Flash device interface code description	x 8, x 16 Async.
2Ah 2Bh	54h 56h	0006h 0000h	Maximum number of bytes in multiple-byte program or page = 2^n	64
2Ch	58h	0001h	Number of Erase block regions. It specifies the number of regions containing contiguous Erase blocks of the same size.	1
2Dh 2Eh	5Ah 5Ch	007Fh 0000h	Erase block region 1 information Number of Erase blocks of identical size = 007Fh +1	128
2Fh 30h	5Eh 60h	0000h 0002h	Erase block region 1 information Block size in region 1 = 0200h * 256 byte	128 Kbytes
31h 32h 33h 34h	62h 64h 66h 68h	0000h 0000h 0000h 0000h	Erase block region 2 information	0
35h 36h 37h 38h	6Ah 6Ch 6Eh 70h	0000h 0000h 0000h 0000h	Erase block region 3 information	0
39h 3Ah 3Bh 3Ch	72h 74h 76h 78h	0000h 0000h 0000h 0000h	Erase block region 4 information	0

Table 39. Primary algorithm-specific extended query table ⁽¹⁾

Address		Data	Description	Value
x 16	x 8			
40h	80h	0050h	Primary algorithm extended query table unique ASCII string "PRI"	'P'
41h	82h	0052h		'R'
42h	84h	0049h		'I'
43h	86h	0031h	Major version number, ASCII	'1'
44h	88h	0033h	Minor version number, ASCII	'3'
45h	8Ah	0010h	Address sensitive unlock (bits 1 to 0) 00 = required, 01 = not required Silicon revision number (bits 7 to 2)	Yes
46h	8Ch	0002h	Erase Suspend 00 = not supported, 01 = Read only, 02 = read and write	2
47h	8Eh	0001h	Block protection 00 = not supported, x = number of blocks per group	1
48h	90h	0000h	Temporary block unprotect 00 = not supported, 01 = supported	Not supported
49h	92h	0008h	Block protect /unprotect 06 = M29W128GH/M29W128GL	6
4Ah	94h	0000h	Simultaneous operations: not supported	NA
4Bh	96h	0000h	Burst mode, 00 = not supported, 01 = supported	Not supported
4Ch	98h	0002h	Page mode, 00 = not supported, 02 = 8-word page	02
4Dh	9Ah	00B5h	V _{PPH} supply minimum Program/Erase voltage bit 7 to 4 HEX value in volts bit 3 to 0 BCD value in 100 mV	11.5 V
4Eh	9Ch	00C5h	V _{PPH} supply maximum Program/Erase voltage bit 7 to 4 HEX value in volts bit 3 to 0 BCD value in 100 mV	12.5 V
4Fh	9Eh	00xxh	Top/bottom boot block flag xx = 04 = uniform device xx = 05 = top/bottom	Uniform + V _{PP} /W _P protecting highest or lowest block
50h	A0h	0001h	Program suspend, 00 = not supported, 01 = supported	Supported

1. The values given in the above table are valid for both packages.

Table 40. Security code area

Address		Data	Description
x 16	x 8		
61h	C3h, C2h	XXXX	64 bit: unique device number
62h	C5h, C4h	XXXX	
63h	C7h, C6h	XXXX	
64h	C9h, C8h	XXXX	

Appendix C Extended memory block

The M29W128GH/L has an extra block, the extended memory block, that can be accessed using a dedicated command. This extended memory block is 128 words in x 16 mode and 256 bytes in x 8 mode. It is used as a security block (to provide a permanent security identification number) or to store additional information.

The device can be shipped either with the extended memory block factory locked, or factory unlocked.

If the extended memory block is not factory locked, it can be customer lockable. Its status is indicated by bit DQ7. This bit is permanently set to either '1' or '0' at the factory and cannot be changed. When set to '1', it indicates that the device is factory locked and the extended memory block is protected. When set to '0', it indicates that the device is customer lockable. Bit DQ7 being permanently locked to either '1' or '0' is another security feature which ensures that a customer lockable device cannot be used instead of a factory locked one.

Bit DQ7 is the most significant bit in the Extended Memory Block Verify Indicator. It can be read in Auto Select mode using either the Programmer (see [Table 8](#) and [Table 9](#)) or the In-system method (see [Table 10](#) and [Table 11](#)).

The extended memory block can only be accessed when the device is in Extended Memory Block mode. For details of how the Extended Memory Block mode is entered and exited, refer to the [Section 6.3.1: Enter Extended Memory Block command](#) and [Section 6.3.2: Exit Extended Memory Block command](#), and to [Table 15](#) and [Table 10](#).

C.1 Factory locked extended memory block

In devices where the extended memory block is factory locked, the security identification number is written to the extended memory block address space (see [Table 41: Extended memory block address and data](#)) in the factory. The DQ7 bit is set to '1' and the extended memory block cannot be unprotected.

C.2 Customer lockable extended memory block

A device where the extended memory block is customer lockable is delivered with the DQ7 bit set to '0' and the extended memory block unprotected. It is up to the customer to program and protect the extended memory block but care must be taken because the protection of the extended memory block is not reversible.

If the device has not been shipped with the extended memory block factory protected, the block can be protected by setting the Extended Memory Block Protection bit, DQ0, to '0'.

However, this bit is one-time programmable and once protected the extended memory block cannot be unprotected.

Once the extended memory block is programmed, the Exit Extended Memory Block command must be issued to exit the Extended Memory Block mode and return the device to Read mode.

Table 41. Extended memory block address and data

Address ⁽¹⁾		Data	
x 8	x 16	Factory locked	Customer lockable
000000h-0000FFh	000000h-00007Fh	Security identification number	Determined by customer

1. See [Table 34: Block addresses](#).

Appendix D Flowcharts

Figure 28. Write to Buffer Program flowchart and pseudocode

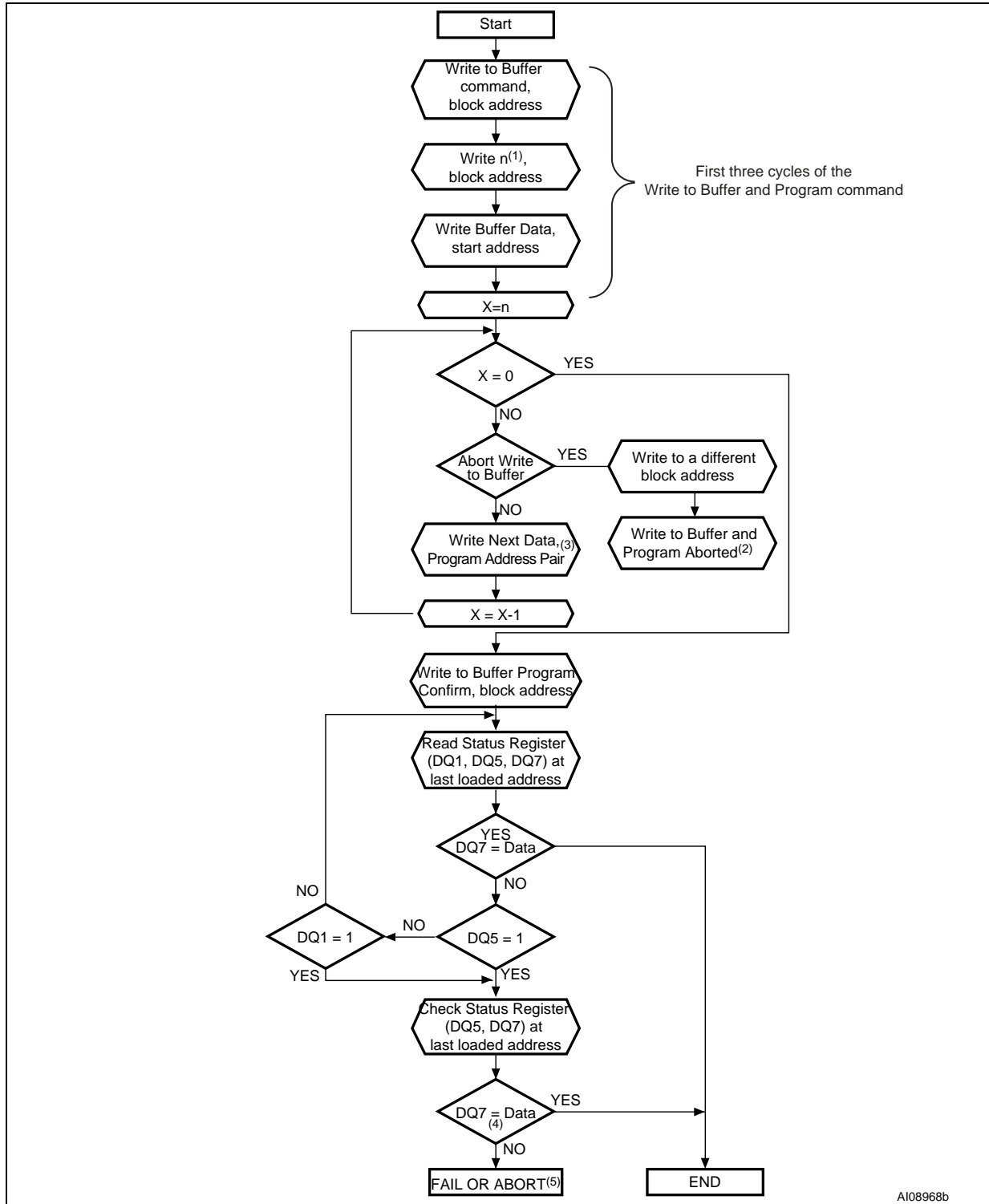

1. n+1 is the number of addresses to be programmed.

2. A Write to Buffer Program Abort and Reset must be issued to return the device in Read mode.
3. When the block address is specified, any address in the selected block address space is acceptable. However when loading write buffer address with data, all addresses must fall within the selected write buffer page.
4. DQ7 must be checked since DQ5 and DQ7 may change simultaneously.
5. If this flowchart location is reached because DQ5='1', then the Write to Buffer Program command failed. If this flowchart location is reached because DQ1='1', then the Write to Buffer Program command aborted. In both cases, the appropriate reset command must be issued to return the device in Read mode: a Reset command if the operation failed, a Write to Buffer Program Abort and Reset command if the operation aborted.
6. See [Table 10](#) and [Table 11](#), for details on Write to Buffer Program command sequence.

Figure 29. Enhanced Buffered Program flowchart and pseudocode

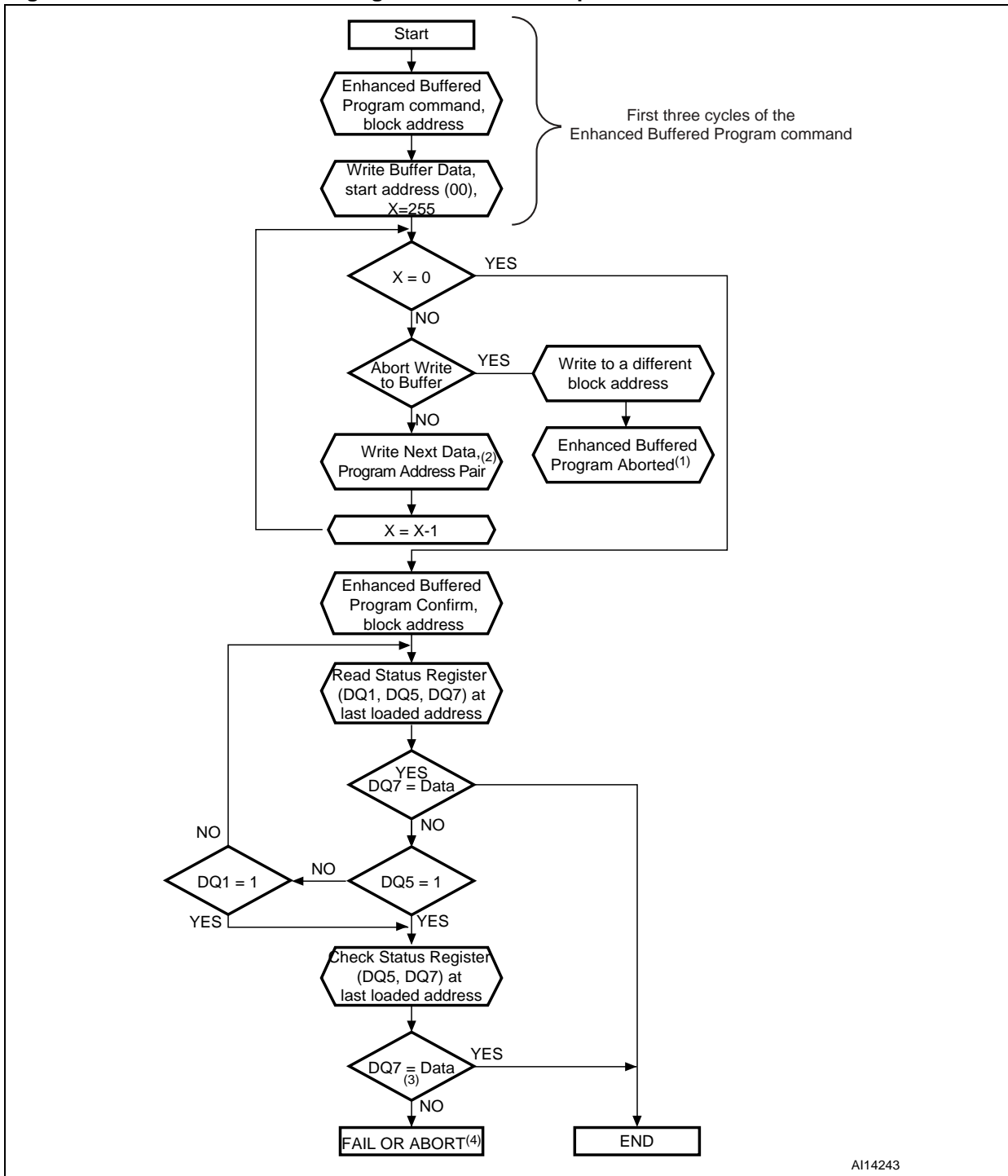

1. A Buffered Program Abort and Reset must be issued to return the device in Read mode.
2. When the block address is specified, all the addresses in the selected block address space must be issued starting from (00). Furthermore, when loading write buffer address with data, data program addresses must be consecutive.
3. DQ7 must be checked since DQ5 and DQ7 may change simultaneously.
4. If this flowchart location is reached because DQ5='1', then the Enhanced Buffered Program command failed. If this flowchart location is reached because DQ1='1', then the Enhanced Buffered Program command aborted. In both cases, the appropriate reset command must be issued to return the device in Read mode: a Reset command if the operation failed, a

Buffered Program Abort and Reset command if the operation aborted.

5. See [Table 14: Enhanced Buffered Program commands, 16-bit mode](#), for details on Enhanced Buffered Program command sequence.

12 Revision history

Table 42. Document revision history

Date	Version	Changes
24-Nov-2006	0.1	Initial release.
30-Mar-2007	1	<p>V_{IO} changed to V_{CCQ} in the whole document and added in Table 21: Absolute maximum ratings.</p> <p>Chip Program time without V_{PPH} updated in Features section.</p> <p>\overline{RP} signal acting as a Reset input, unprotection of all the blocks previously protected using a High Voltage Block Protection technique removed.</p> <p>Table 4: Bus operations, 8-bit mode and Table 5: Bus operations, 16-bit mode updated. Table 6: Read electronic signature - auto select mode - programmer method (8-bit mode) and Table 7: Read electronic signature - auto select mode - programmer method (16-bit mode) updated. Table 8: Block protection - auto select mode - programmer method (8-bit mode) and Table 9: Block protection - auto select mode - programmer method (16-bit mode) updated.</p> <p>Section 5: Software protection added, together with the related commands.</p> <p>Unlock Bypass Block Erase, Unlock Bypass Chip Erase, and Unlock Write to Buffer and Program commands added.</p> <p>Lock Register description added in Section 7.1.</p>
23-Oct-2007	2	<p>Enhanced Buffered Program commands added (see on page 1 and from Section 6.2.2 to Section 6.2.12).</p> <p>Modified values for page access, random access, programming time, and chip program time on page 1. Speed classes changed in Table 27, Table 28, Table 29, Table 30, and Table 33.</p> <p>Table 14: Enhanced Buffered Program commands, 16-bit mode added.</p> <p>Table 12, Table 13, Table 15, Table 16, Table 17, Table 22, Table 26, Table 37, and Table 39 updated as well as Figure 22.</p> <p>Figure 29: Enhanced Buffered Program flowchart and pseudocode added in Appendix D.</p>
28-Jan-2008	3	<p>Document status promoted from preliminary data to datasheet.</p> <p>Speed classes and page size modified on page 1.</p> <p>Modified: Section 2.8: VPP/Write Protect (VPP/WP), Section 3.6: Automatic Standby, Section 6.1.5: Block Erase command, Table 3: VPP/WP functions, Table 22: Operating and AC measurement conditions, Table 25: DC characteristics, and Table 39: Primary algorithm-specific extended query table.</p> <p>Added: Table 23: Power-up waiting timings and Figure 12: Power-up waiting timings.</p> <p>Changed Erase Suspend latency time in Table 17: Program, Erase times and Program, Erase endurance cycles.</p> <p>Minor text changes.</p>

Please Read Carefully:

Information in this document is provided solely in connection with ST products. STMicroelectronics NV and its subsidiaries ("ST") reserve the right to make changes, corrections, modifications or improvements, to this document, and the products and services described herein at any time, without notice.

All ST products are sold pursuant to ST's terms and conditions of sale.

Purchasers are solely responsible for the choice, selection and use of the ST products and services described herein, and ST assumes no liability whatsoever relating to the choice, selection or use of the ST products and services described herein.

No license, express or implied, by estoppel or otherwise, to any intellectual property rights is granted under this document. If any part of this document refers to any third party products or services it shall not be deemed a license grant by ST for the use of such third party products or services, or any intellectual property contained therein or considered as a warranty covering the use in any manner whatsoever of such third party products or services or any intellectual property contained therein.

UNLESS OTHERWISE SET FORTH IN ST'S TERMS AND CONDITIONS OF SALE ST DISCLAIMS ANY EXPRESS OR IMPLIED WARRANTY WITH RESPECT TO THE USE AND/OR SALE OF ST PRODUCTS INCLUDING WITHOUT LIMITATION IMPLIED WARRANTIES OF MERCHANTABILITY, FITNESS FOR A PARTICULAR PURPOSE (AND THEIR EQUIVALENTS UNDER THE LAWS OF ANY JURISDICTION), OR INFRINGEMENT OF ANY PATENT, COPYRIGHT OR OTHER INTELLECTUAL PROPERTY RIGHT.

UNLESS EXPRESSLY APPROVED IN WRITING BY AN AUTHORIZED ST REPRESENTATIVE, ST PRODUCTS ARE NOT RECOMMENDED, AUTHORIZED OR WARRANTED FOR USE IN MILITARY, AIR CRAFT, SPACE, LIFE SAVING, OR LIFE SUSTAINING APPLICATIONS, NOR IN PRODUCTS OR SYSTEMS WHERE FAILURE OR MALFUNCTION MAY RESULT IN PERSONAL INJURY, DEATH, OR SEVERE PROPERTY OR ENVIRONMENTAL DAMAGE. ST PRODUCTS WHICH ARE NOT SPECIFIED AS "AUTOMOTIVE GRADE" MAY ONLY BE USED IN AUTOMOTIVE APPLICATIONS AT USER'S OWN RISK.

Resale of ST products with provisions different from the statements and/or technical features set forth in this document shall immediately void any warranty granted by ST for the ST product or service described herein and shall not create or extend in any manner whatsoever, any liability of ST.

ST and the ST logo are trademarks or registered trademarks of ST in various countries.

Information in this document supersedes and replaces all information previously supplied.

The ST logo is a registered trademark of STMicroelectronics. All other names are the property of their respective owners.

© 2008 STMicroelectronics - All rights reserved

STMicroelectronics group of companies

Australia - Belgium - Brazil - Canada - China - Czech Republic - Finland - France - Germany - Hong Kong - India - Israel - Italy - Japan - Malaysia - Malta - Morocco - Singapore - Spain - Sweden - Switzerland - United Kingdom - United States of America

www.st.com