Description

The CXA4011GC is a SPDT antenna switch for GSM/3G/LTE switching applications.
The CXA4011GC has a 1.8V CMOS compatible decoder.
The Sony Silicon On Insulator (SOI) technology is used for low insertion loss.

Features

- ◆ Low Insertion loss : 0.22 dB(typ.) at 800 MHz
0.23 dB(typ.) at 2 GHz
0.25 dB(typ.) at 2.7 GHz
- ◆ No DC Blocking Capacitors (except sourcing DC bias)
- ◆ Solder Bump Bare Die(SBBD) : Bump Pitch = 0.4 mm
- ◆ Small Flip-Chip Size : 1.1 mm x 1.1 mm x 0.35 mm Typ.
- ◆ Lead-Free and RoHS compliant
- ◆ Applications: Diversity Switch, GSM/3G/LTE Tx Switch

Structure

SOI CMOS MMIC

This IC is ESD sensitive device. Special handling precautions are required

Block Diagram

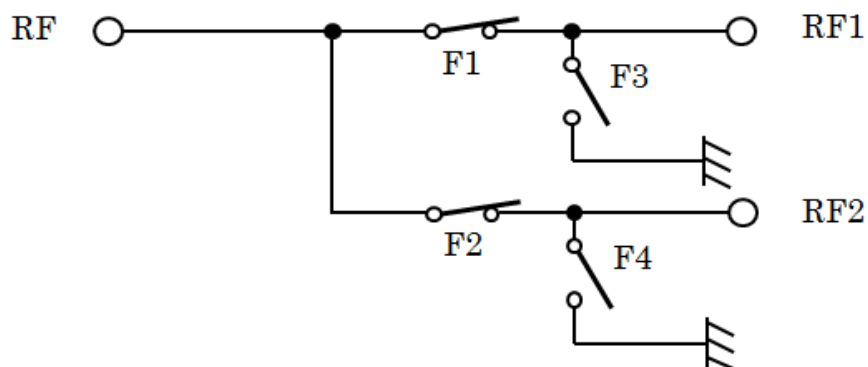
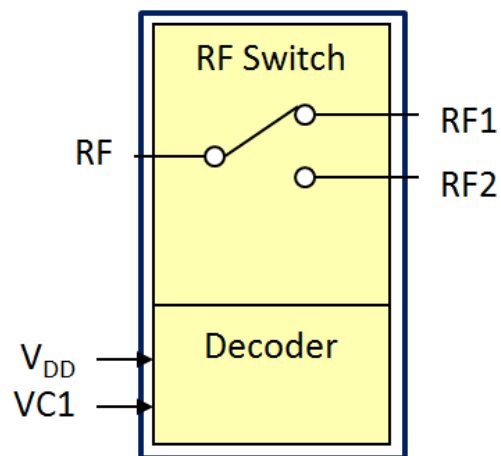

Truth Table

ON Path	VC1	F1	F2	F3	F4
RF – RF1	L	ON	OFF	OFF	ON
RF – RF2	H	OFF	ON	ON	OFF

Pin Configuration

Chip Size: 1.1 × 1.1 mm (0.4 mm Pitch)

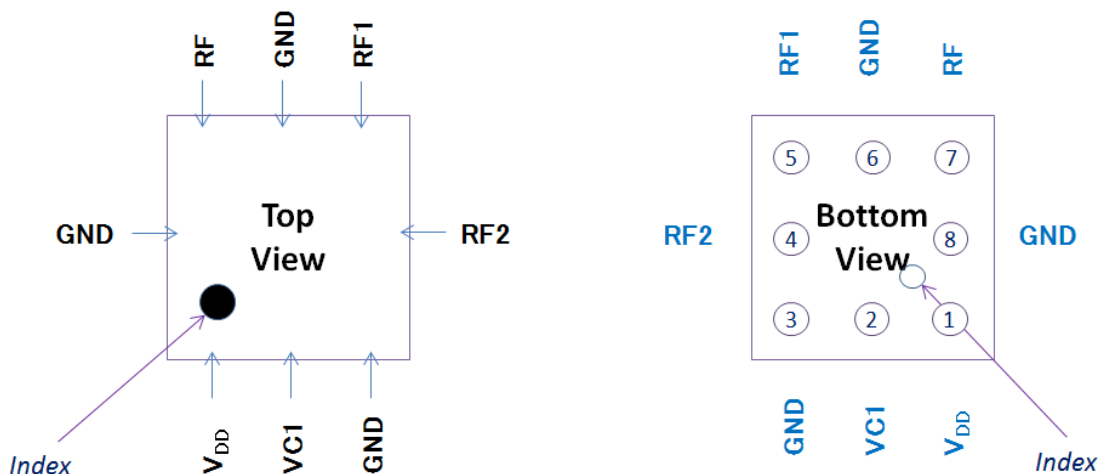

Absolute Maximum Ratings

◆ Supply voltage	V_{DD}	4	V	($T_a = 25\text{ }^\circ\text{C}$)
◆ Control voltage	VC	4	V	($T_a = 25\text{ }^\circ\text{C}$)
◆ Maximum input		37	dBm	($T_a = 25\text{ }^\circ\text{C}$, $V_{DD}=2.45\text{ to }3.3\text{V}$)
◆ Operating temperature	T_{opr}	-35 to +90	$^\circ\text{C}$	
◆ Storage temperature	T_{stg}	-65 to +150	$^\circ\text{C}$	

DC Bias Condition

($T_a=25^\circ\text{C}$)

Parameter	Min.	Typ.	Max.	Unit
V_{DD}	2.45	2.65	3.3	V
VC(H)	1.35	1.8	3.3	V
VC(L)	0	-	0.45	V

Electrical Characteristics

(V_{DD}=2.65V, T_a=25°C)

Item	Symbol	Path	Condition	Min.	Typ.	Max.	Unit
Insertion Loss	IL	RF - RF1	*1	—	0.22	0.32	dB
			*2	—	0.26	0.41	
			*3	—	0.27	0.42	
			*4	—	0.30	0.45	
		RF - RF2	*1	—	0.22	0.32	
			*2	—	0.23	0.38	
			*3	—	0.23	0.38	
			*4	—	0.25	0.40	
Isolation	ISO	RF - RF1,2	*1	42	47	—	dB
			*2	31	36	—	
			*3	30	35	—	
			*4	26	31	—	
		RF1 - RF2	*1	34	39	—	
			*2	28	31	—	
			*3	27	30	—	
			*4	25	28	—	
VSWR	VSWR		704 to 2170 MHz	—	1.1	1.3	—
			2500 to 2690 MHz	—	1.15	1.4	
Harmonics	2fo 3fo 2fo 3fo 2fo 3fo 2fo 3fo	RF-RF1,2	*5	—	—	-45	dBm
			*6	—	—	-45	
			*7	—	—	-55	
			*8	—	—	-55	
			*9	—	—	-55	
			*10	—	—	-55	
			*11	—	—	-55	
			*12	—	—	-55	
Inter Modulation Product Power in Rx Band	IMD2	RF- RF1, 2	*9, *17	—	—	-110	dBm
			*10-12, *17	—	—	-110	
	IMD3		*13, *17	—	—	-110	
			*14-16, *17	—	—	-110	
Control Current	I _{ctl}		VC = 1.8 V per line	—	0.05	1	μ A
Supply Current	I _{dd}		V _{DD} = 2.5 V	—	13	30	μ A
Switching Speed	T _s		50 % VC to 90 % RF	—	3	5	μ S
Wake up time	T _w		Wakeup time from V _{DD} on to Active mode	—	10	30	μ S

Electrical Characteristics are measured with all RF ports terminated in 50 Ω.

- * 1 freq = 704 to 960 MHz
- * 2 freq = 1710 to 1990 MHz
- * 3 freq = 2110 to 2170 MHz
- * 4 freq = 2500 to 2690 MHz
- * 5 Pin = 34dBm, freq = 824 to 915 MHz
- * 6 Pin = 31dBm, freq = 1710 to 1910 MHz
- * 7 Pin = 24dBm, freq = 1920 to 1980 MHz
- * 8 Pin = 23dBm, freq = 2500 to 2570 MHz
- * 9 Pin on RF: 20dBm, 835MHz, Pin on ANT: -15dBm, 45MHz
- * 10 Pin on RF: 20dBm, 1745MHz, Pin on ANT: -15dBm, 95MHz
- * 11 Pin on RF: 20dBm, 1880MHz, Pin on ANT: -15dBm, 80MHz
- * 12 Pin on RF: 20dBm, 1950MHz, Pin on ANT: -15dBm, 190MHz
- * 13 Pin on RF: 20dBm, 835MHz, Pin on ANT: -15dBm, 790MHz
- * 14 Pin on RF: 20dBm, 1745MHz, Pin on ANT: -15dBm, 1650MHz
- * 15 Pin on RF: 20dBm, 1880MHz, Pin on ANT: -15dBm, 1800MHz
- * 16 Pin on RF: 20dBm, 1950MHz, Pin on ANT: -15dBm, 1760MHz
- * 17 Measured with the recommended circuit

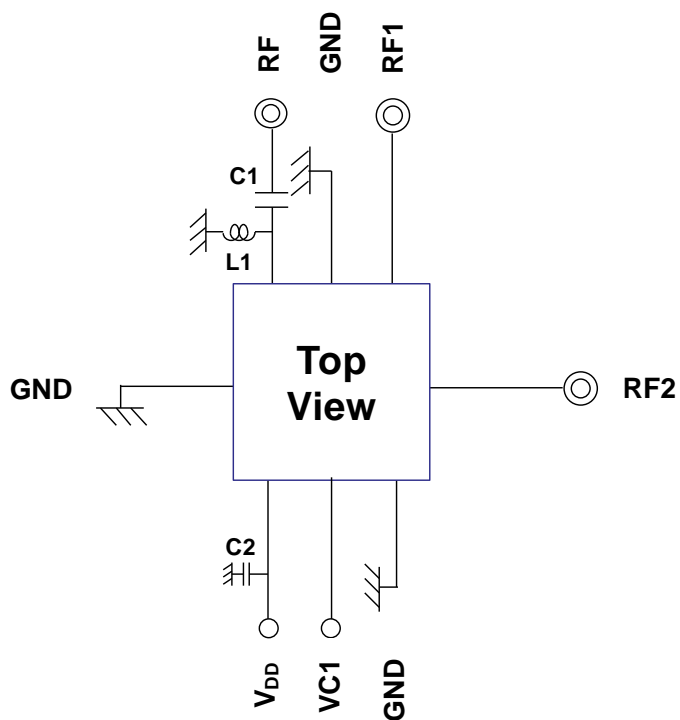
Recommended Circuit

*1: No DC blocking capacitors are required on all RF ports.

*2: DC levels of all RF ports are GND.

*3: L1 (27 nH) and C1 (12 pF) are recommended on Ant port for ESD protection.

*4: C2(100 pF) is recommended on V_{DD} pin for Decoupling Capacitor.

Solder Bump Foot Print (Macro) Reference

Device specification

- Device size : 1.1 mm × 1.1 mm × t 0.35 mm
- Pin counts : 8 Pin
- Solder Bump height : 0.15 mm
- Solder Bump ball size : ϕ 0.2 mm
- Solder Bump pitch : 0.4 mm

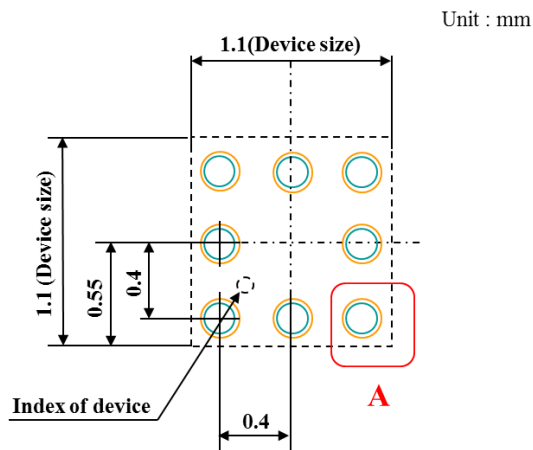

Detail - A

- Land size (Resist Open area) : ϕ 200 μ m
- Cu pattern size : (ϕ 300 μ m)

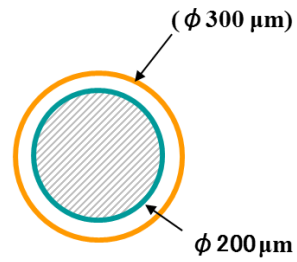

- : Cu pattern
- : Resist open
- ▨ : Solder print area (Metal mask thickness : 110 μ m)

Recommended PCB Layout

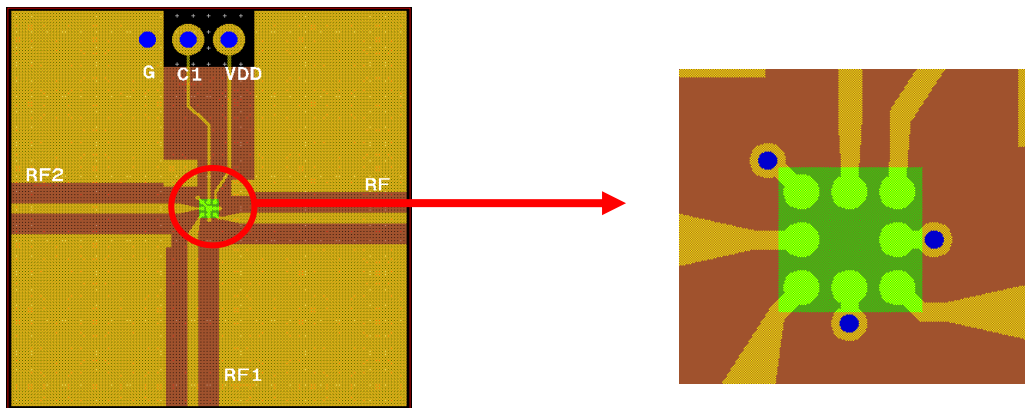

- Device Area
- Via
- Metal Pattern

Package Outline

Unit : mm

8 PIN XFLGA

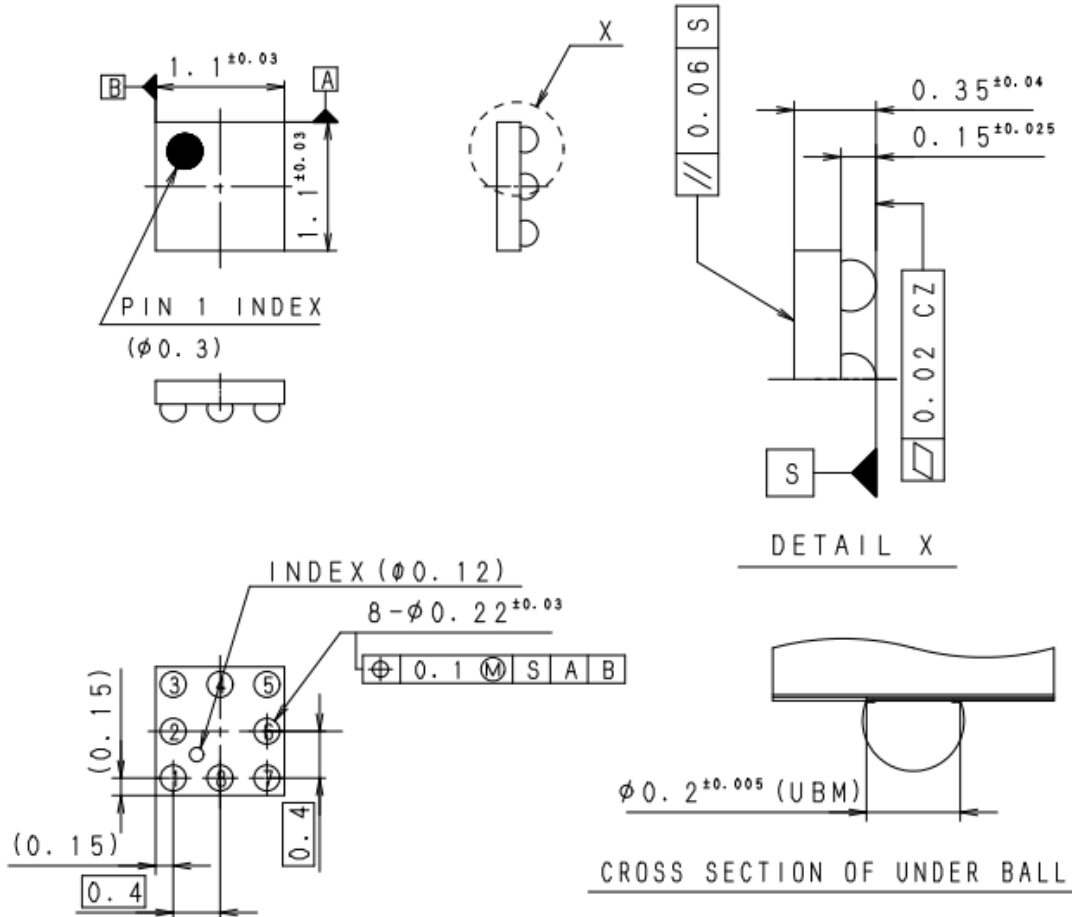

PACKAGE STRUCTURE

SONY CODE	XFLGA-8S-433
JEITA CODE	S-XFLGA-1.1x1.1-0.4
JEDEC CODE	_____

PACKAGE MATERIAL	Si SUBSTRATE
TERMINAL MATERIAL	Sn-3.0Ag-0.5Cu
PACKAGE MASS	0.0008g

PART No.	AP-2000-8LGAS3	Rev. 0
ISSUED	13.02.05	REVISED
PRODUCTION LINE	COMPILING DIV. SONY SEMICONDUCTOR.	
REMARKS	PKG CORD:GX-8-BAS	

Tape and Reel Size

CXA4011GC-T9

Unit : mm

8 mm WIDTH EMBOSSED TAPING
(FOR Sony Mobile Communications, Inc.)

PACKAGE CODE	EMBOSSED TAPING CODE
XFLGA-8S-433	R008XL11-08-N-1

1. SCOPE

THIS SPECIFICATION DESCRIBES THE EMBOSSED TAPING FOR SMD (SURFACE MOUNTED DEVICE) IC'S. FOR SHIPMENT. THIS SPECIFICATION IS BASED ON THE STIPULATIONS OF JAPAN ELECTRONICS AND INFORMATION TECHNOLOGY INDUSTRIES ASSOCIATION (JEITA), JIS C0806-3, AND ELECTRONIC INDUSTRIES ASSOCIATION EIA-481.

2. PRODUCT INDICATION

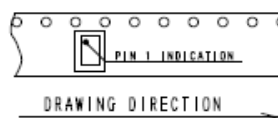
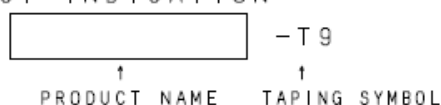

3. TAPING SPECIFICATIONS

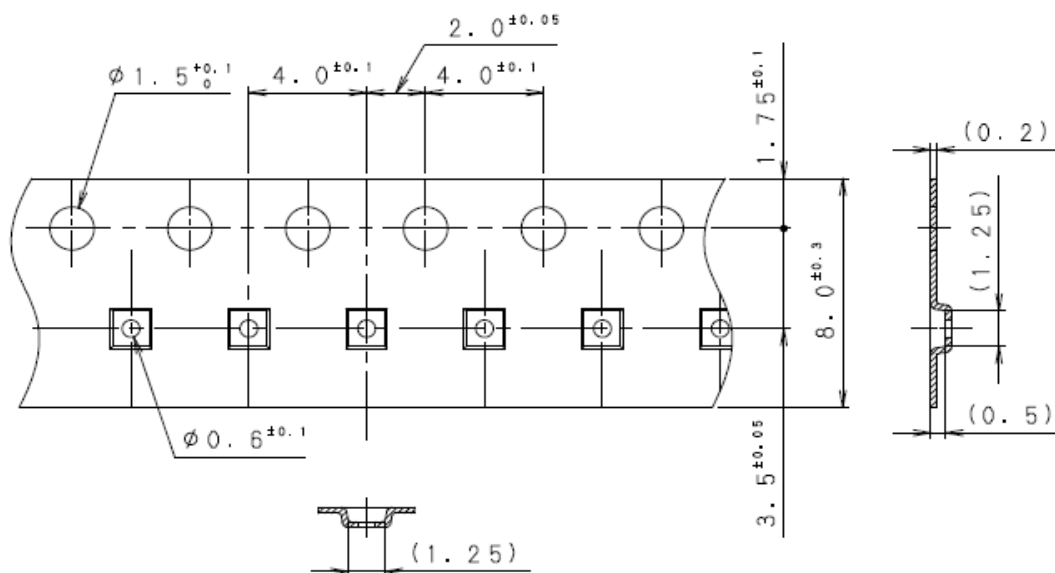

NOTE) 1. THE R MEASUREMENT WITHOUT INDICATION IS ASSUMED TO BE 0.3mm MAX. GENERAL TOLERANCE: ± 0.2
 2. THE FEED HOLE CUMULATIVE PITCH ERROR IS ASSUMED AT ± 0.2 mm/10 PITCH. UNIT: mm

4. REEL DIMENSIONS

$\phi 180$ mm PLASTIC REEL

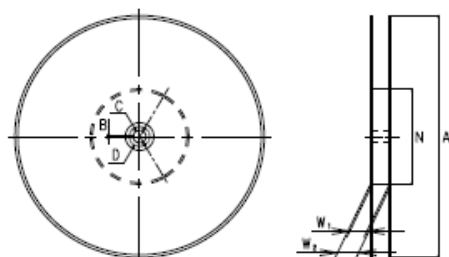

UNIT : mm

SYMBOL	A	N	C	D
DIMENSION	$\phi 180 \pm 2$	$\phi 54^{+2}$	$\phi 13^{+1}$	$\phi 20.2^{+0.2}$
SYMBOL	B	W ₁	W ₂	
DIMENSION	$1.5^{+0.2}$	$8.4^{+0.2}$	12.4 ± 2	

MATERIAL: POLYSTYRENE CONTAINING CARBON (ANTISTATIC)

Marking

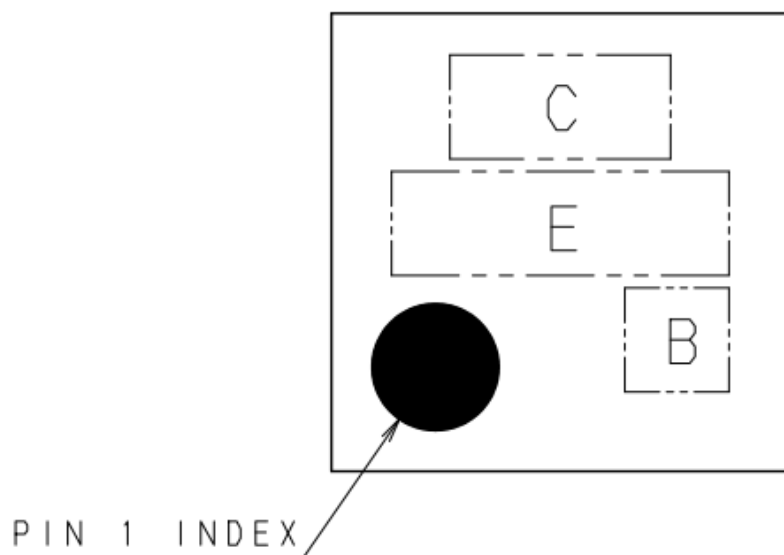

MARKING C: AR

- 注1) C部は製品名 (Max 2文字) を配置する。
(2文字を超える場合は製品名省略標示規定に従う。)
- 2) B部は製造年 (1文字) を配置する。
- 3) E部は通し記号 (MAX 3文字) を配置する。

< INSTRUCTIONS >

- 1) TYPE NO. (MAX 2 CHARACTERS) IN SECTION C.
(FOR MORE THAN 2 CHARACTERS FOLLOW RULES FOR ABBREVIATIONS.)
- 2) MANUFACTURING YEAR (1 CHARACTER) IN SECTION B.
- 3) SERIAL CODE (MAX 3 CHARACTERS) IN SECTION E.

Moisture Sensitivity

Moisture Sensitivity Level for this part is MSL = 1

Note: The MSL of this product contains the following storage conditions (Taping).

Storage period

(With or without opening moisture-proof packing)

⇒The storage time limit shall be 1 year or less under storage environment conditions of temperature 30°C or less and humidity 85%RH or less.

*This device is unnecessary management of moisture sensitivity.

However, we will assume 1 year for the convenience of seal strength of the taping product.

Avoid storage in locations exposed to direct sunlight, locations where corrosive gases are generated, or dusty locations.

Note

Sony reserves the right to change products and specifications without prior notice.

This information does not convey any license by any implication or otherwise under any patents or other right.

Application circuits shown, if any, are typical examples illustrating the operation of the devices. Sony cannot assume responsibility for any problems arising out of the use of these circuits