

Apollo3 Blue EVB Board Revision 1.0 Quick Start Guide

**Doc. ID: QS-A3B-1p00
Document Revision 1.0**

Table of Content

Introduction	5
Document Revision History.....	5
Overview of the Apollo3 Blue EVB.....	6
Debug Interface	8
Software Development Tools.....	11
Power Supply Options and Measuring Current.....	12

List of Figures

Apollo3 Blue EVB, Revision 1.0.....	6
Apollo3 Blue EVB Parts Location.....	6
Apollo3 Blue EVB using On-board J-Link Debugger	8
Apollo3 Blue EVB's Cortex DEBUG IN Header (J1).....	9
Apollo3 Blue EVB's DEBUG OUT Header (J2).....	10
Voltage Selection on Header P19.....	12
Header P19 Configured for 3.3V Operation - No Current Measurement	13
Header P19 Configured for 3.3V Operation - With Current Measurement	13

List of Tables

Document Revision History.....	5
Jumper Configuration for Power Selections.....	12

1. Introduction

This document provides guidance in setting up the Apollo3 Blue Evaluation Board (EVB), part number AMA3BEVB, revision 1.0, to get started executing code examples, measuring power consumption in various configurations, and beginning software development.

2. Document Revision History

Rev #	Date	Description
1.0	Jul 2018	Document initial public release

Table 1: Document Revision History

3. Overview of the Apollo3 Blue EVB

The Apollo3 Blue EVB features Arduino-compatible headers and an integrated J-Link debugger:

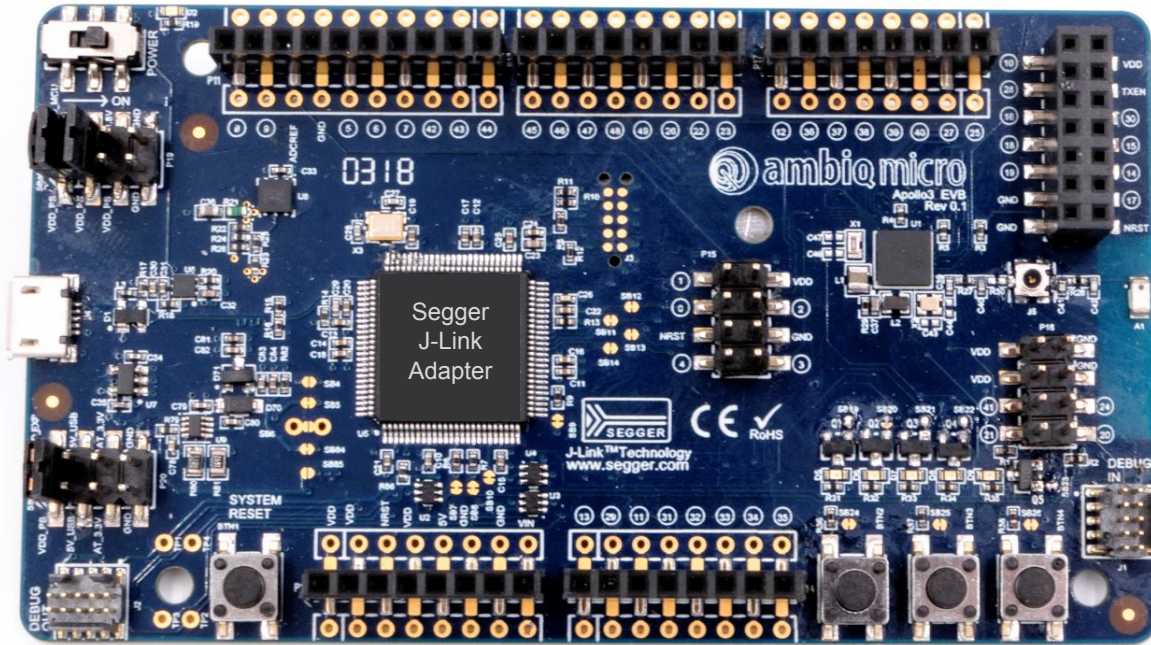

Figure 1. Apollo3 Blue EVB, Revision 1.0

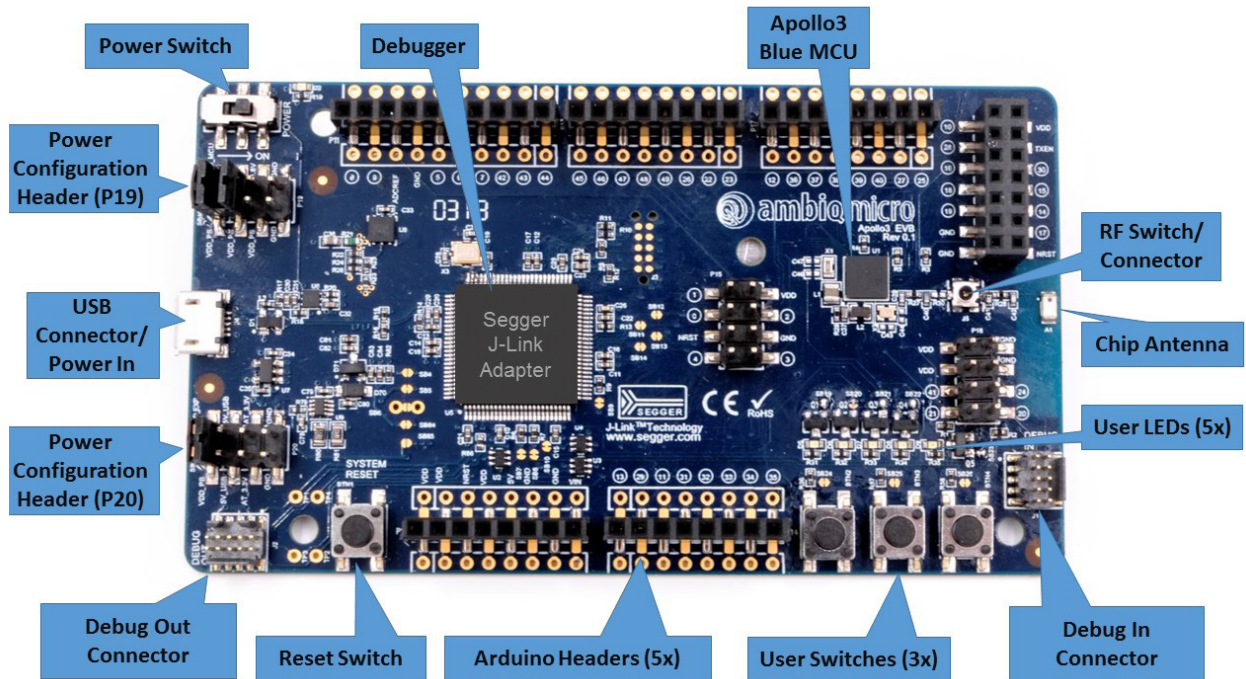

Figure 2. Apollo3 Blue EVB Parts Location

The EVB has these additional features:

- Low power reference design
- Apollo3 Blue MCU in the BGA package (AMA3B1KK-KBR)
- Multiple power/clock options
- Micro USB connector for power/download/debug
- On-board chip antenna (A1)
- RF switch/connector (J1 - Murata MM8430-2610RA1) for BLE PHY testing without removing chip antenna
- Segger J-Link debugger
- Debugger-in / debugger-out ports
- Five user-controlled LEDs
- Three push buttons for application use, plus a reset push button
- Power slide switch with LED power indicator
- Five 8-12 pin Arduino-style headers for pin/power access to shield board(s)
- Multiple test points for power measurements
- CE Mark and RoHS compliant

3.1 Secure Boot on the Apollo3 Blue MCU

Apollo3 Blue MCU parts from the Ambiq Micro factory are preprogrammed with a Secure Bootloader and an uninitialized Customer InfoSpace, referred to as INFO0. Initial provisioning of the part would include programming a valid INFO0 and programming the main firmware image in the flash. The Apollo3 Blue EVB is shipped with the INFO0 configuration preprogrammed with optimal settings for the EVB layout.

For your reference, the following settings are programmed into INFO0 on the Apollo3 Blue MCU resident on the EVB:

- Simo Buck is enabled, which provides lowest Apollo3 power consumption in both active and sleep modes.
- Secure Bootloader (SBL) interface is configured to UART using GPIO22 and GPIO23, which allows secure boot to be performed over the J-Link COM interface of the EVB.
- SBL override pin is configured to GPIO16 which is BTN1 on the EVB.
- All Flash and Debugger protection features are disabled.

For information on changing the INFO0 settings as well as using the Secure Bootloader, please refer to the *Apollo3 Blue Getting Started Guide*, which can be found in the Ambiq Micro SDK documentation and example scripts located in the \tools\apollo3_scripts folder. This folder contains a number of python scripts to demonstrate generation of INFO0 settings, customer main images, and the creation of images for the Wired Update protocol over UART.

4. Debug Interface

Figure 3 shows the Apollo3 Blue EVB set up for standard debug using the on-board J-Link debugger and on-board power supply configured for 3.3V.

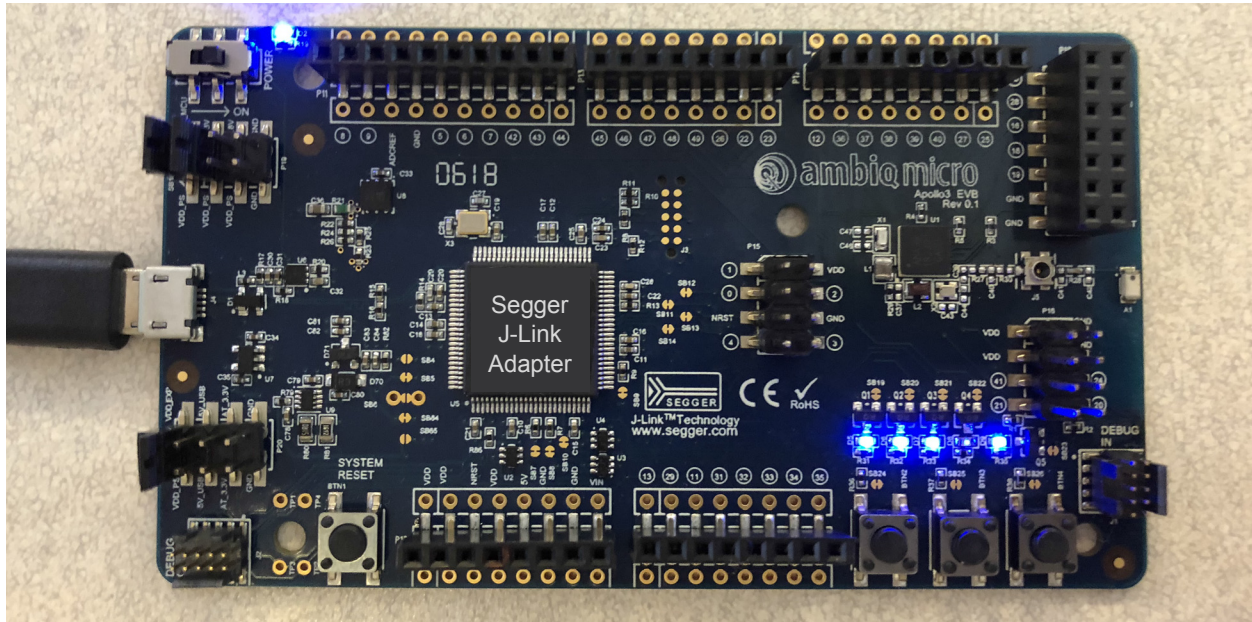

Figure 3. Apollo3 Blue EVB using On-board J-Link Debugger

The debug interface is supported by standard J-Link drivers from Segger. Please refer to “Software Development Tools” on page 11 for more details on J-Link debug support.

4.1 Use of External Debugger

This EVB also supports the use of an external Cortex SWD debug interface through a standard 10-pin debug header (DEBUG IN - J1) as shown in Figure 4.

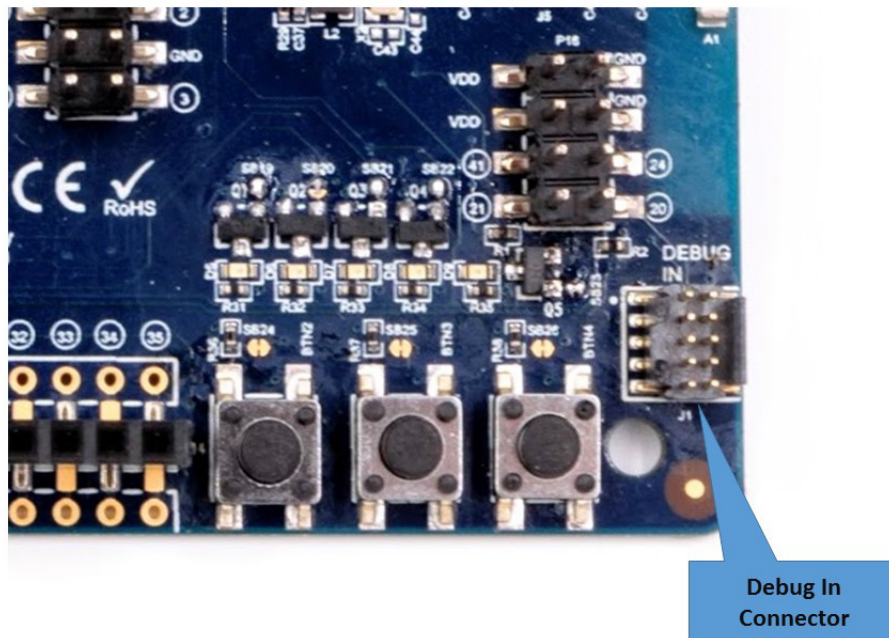

Figure 4. Apollo3 Blue EVB's Cortex DEBUG IN Header (J1)

No jumper changes are required to use an external debug adapter. Simply connect the external debug adapter with a 10-pin ribbon cable connector to the "DEBUG IN" header.

4.2 Use of J-Link Adapter as an External Target Board Debugger

The EVB also offers the ability to be used as a J-Link debug adapter for any target board that has an Apollo family MCU.

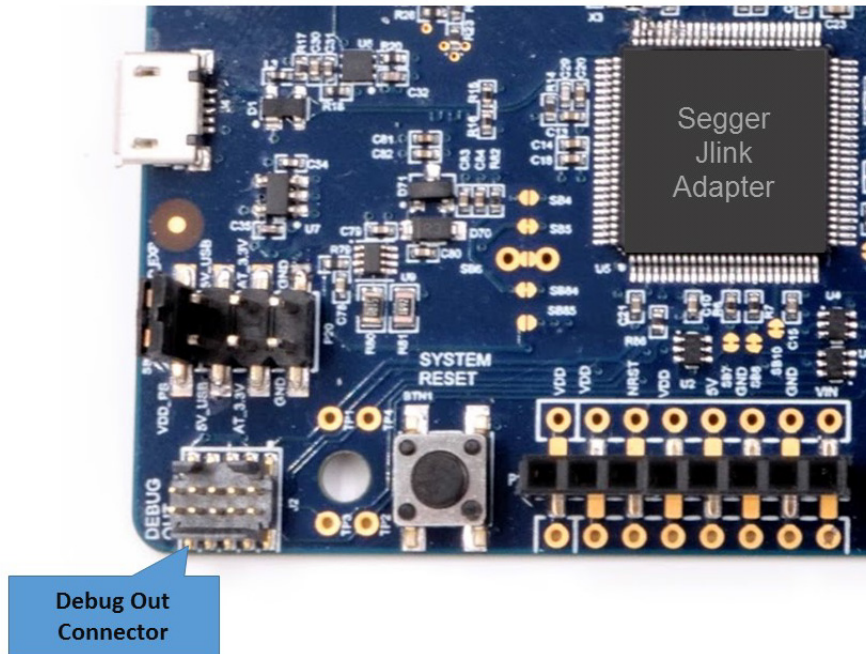

Figure 5. Apollo3 Blue EVB's DEBUG OUT Header (J2)

To utilize this functionality, use a 10-pin low-pitch standard debug connector to connect the “DEBUG OUT” header (J2) on the EVB to the debug header on the target board. The EVB will automatically detect when the “DEBUG OUT” header is connected to another target board and reconfigure the integrated J-Link to connect to this external board rather than the on-board Apollo3 Blue.

Note: A voltage on pin 1 of the J2 header is required for the above mentioned automatic switch to occur. Also, if the target VDD doesn't match the on-board voltage (either 3.3V or 1.8V), and to avoid possible voltage level conflicts on the debug I/O port, VDDIO of the J-Link processor may need to be changed to the target voltage by cutting SB5 and shorting SB6.

5. Software Development Tools

The standard Segger J-Link debug interface is used on the Apollo3 Blue EVB. Please install the latest Beta Segger J-Link software, and configure your preferred development IDE (Keil, IAR, or Eclipse) to use J-Link debug interface.

Links to development tools that support Apollo3 Blue (AMA3B1KK-KBR):

- SEGGER J-Link Software (6.33h Beta or later): <https://www.segger.com/downloads/jlink>
- KEIL uVision (MDK523 or later): <https://www.keil.com/demo/eval/arm.htm>
- New Keil Pack (Also used by Eclipse): <http://www.keil.com/dd2/pack/#/third-party-download-dialog>
- IAR Version 7.80.4 (8.10.1 or later): <https://www.iar.com/iar-embedded-workbench/tools-for-arm/arm-cortex-m-edition/>
- GCC 5.3.1: <https://gcc.gnu.org>

Regardless of preferred IDE, please install the Segger J-Link software. All of the above development environments support J-Link, but you must have the latest J-Link software installed. Most alternate development environments also are supported by J-Link.

Please refer to the AmbiqSuite Getting Started Guide (AMSDKGS) at https://ambiqmicro.com/wp-content/uploads/2017/09/AMSDKGS-v1_1.pdf for more details on setting up development IDEs to use J-Link.

6. Power Supply Options and Measuring Current

There are three power supply options for the Apollo3 Blue EVB:

- Operate at 3.3V as provided by the on-board power supply
- Operate at 1.8V as provided by the on-board power supply
- Provide externally supplied power

Figure 6 shows header P19 which is used to select a power configuration through jumper installations, as well as the option to measure the supply current to the MCU with an ammeter. Solder bridge SB15 can be filled instead of jumpering from pin 1 to pin 2 if current measuring is of no interest.

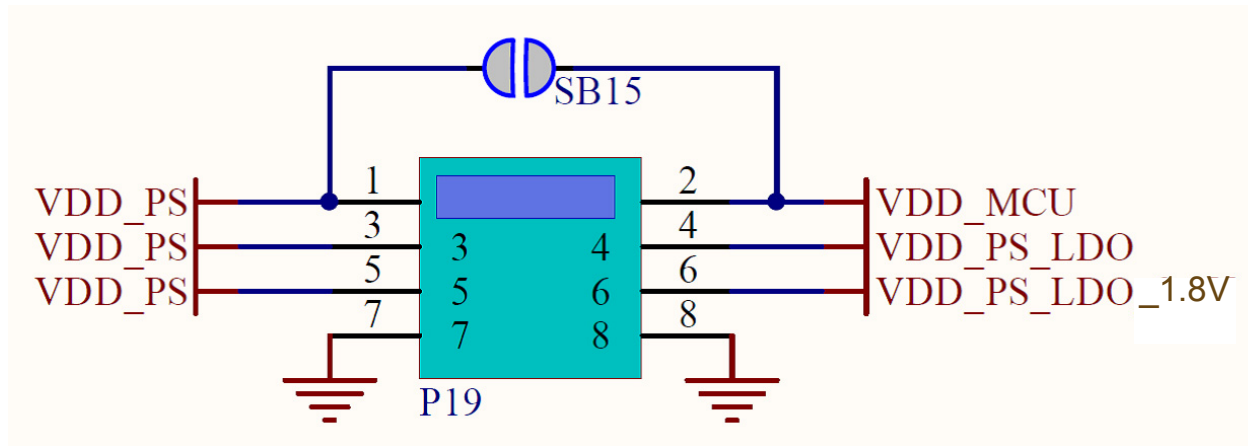

Figure 6. Voltage Selection on Header P19

Table 2: Jumper Configuration for Power Selections

Jumper 1-2	Jumper 3-4	Jumper 5-6	Power Source
In	In	In	1.8V operation from internal regulator
Out	In	Out	Intended for current measuring across pins 1 and 2 during 3.3V operation from internal regulator
Out	In	In	Intended for current measuring across pins 1 and 2 during 1.8V operation from internal regulator
In	Out	Out	Externally-provided supply voltage within the allowable range (1.755-3.60V) on pin 3 or 5
Out	Out	Out	Intended for current measuring across pins 1 and 2 during externally-provided supply voltage within the allowable range (1.755-3.60V) on pin 3 or 5

As an example for setting the jumpers on P19, Figure 7 shows the EVB configured for 3.3V operation with jumper across VDD_PS and VDD_MCU for no current measurement.

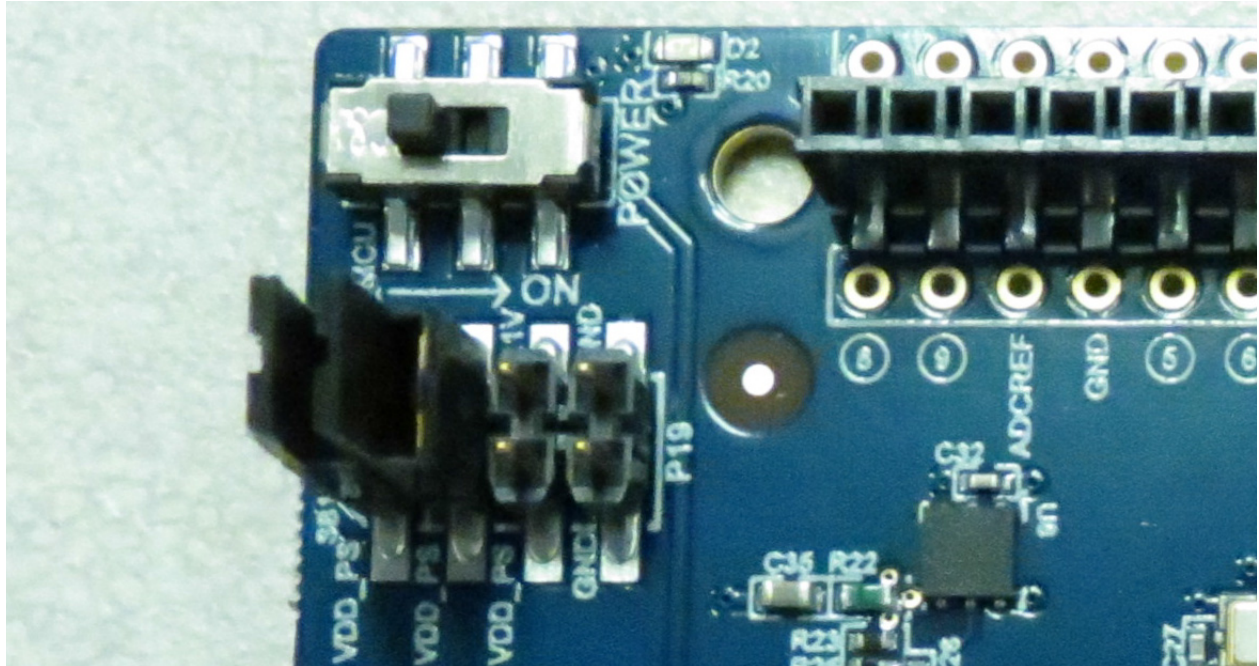

Figure 7. Header P19 Configured for 3.3V Operation - No Current Measurement

Figure 8 shows the EVB configured for 3.3V operation with current measuring leads across VDD_PS and VDD_MCU for current measurement.

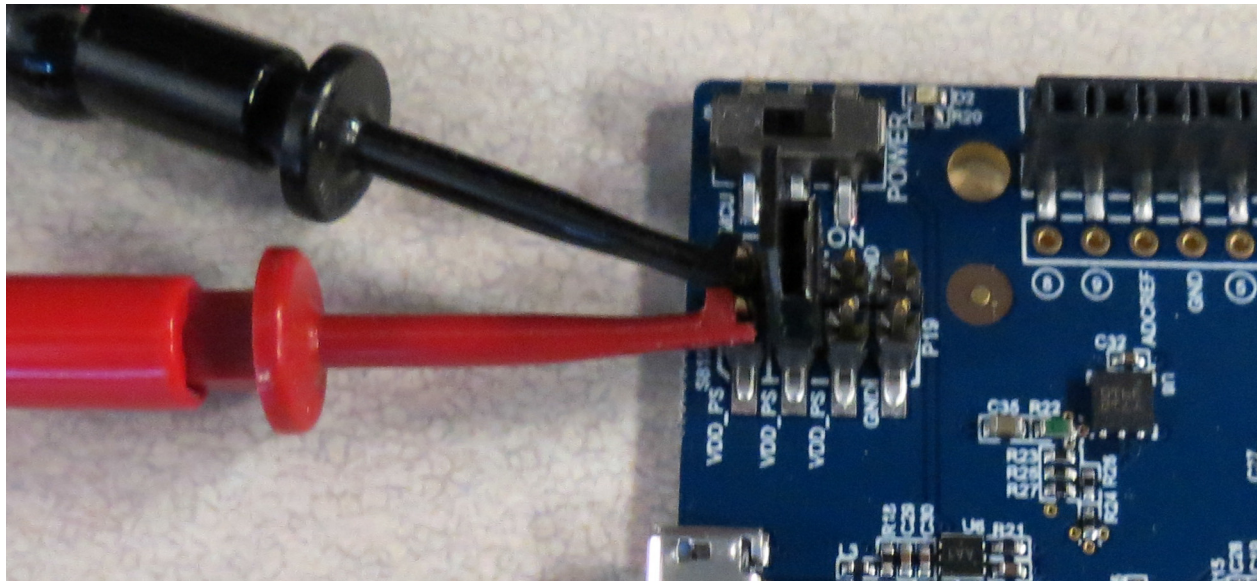

Figure 8. Header P19 Configured for 3.3V Operation - With Current Measurement

Contact Information

Address	Ambiq Micro, Inc. 6500 River Place Blvd. Building 7, Suite 200 Austin, TX 78730-1156
Phone	+1 (512) 879-2850
Website	https://ambiqmicro.com/
Sales	sales@ambiqmicro.com
Technical Support	https://support.ambiqmicro.com

Legal Information and Disclaimers

AMBIQ MICRO INTENDS FOR THE CONTENT CONTAINED IN THE DOCUMENT TO BE ACCURATE AND RELIABLE. THIS CONTENT MAY, HOWEVER, CONTAIN TECHNICAL INACCURACIES, TYPOGRAPHICAL ERRORS OR OTHER MISTAKES. AMBIQ MICRO MAY MAKE CORRECTIONS OR OTHER CHANGES TO THIS CONTENT AT ANY TIME. AMBIQ MICRO AND ITS SUPPLIERS RESERVE THE RIGHT TO MAKE CORRECTIONS, MODIFICATIONS, ENHANCEMENTS, IMPROVEMENTS AND OTHER CHANGES TO ITS PRODUCTS, PROGRAMS AND SERVICES AT ANY TIME OR TO DISCONTINUE ANY PRODUCTS, PROGRAMS, OR SERVICES WITHOUT NOTICE.

THE CONTENT IN THIS DOCUMENT IS PROVIDED "AS IS". AMBIQ MICRO AND ITS RESPECTIVE SUPPLIERS MAKE NO REPRESENTATIONS ABOUT THE SUITABILITY OF THIS CONTENT FOR ANY PURPOSE AND DISCLAIM ALL WARRANTIES AND CONDITIONS WITH REGARD TO THIS CONTENT, INCLUDING BUT NOT LIMITED TO, ALL IMPLIED WARRANTIES AND CONDITIONS OF MERCHANTABILITY, FITNESS FOR A PARTICULAR PURPOSE, TITLE AND NON-INFRINGEMENT OF ANY THIRD PARTY INTELLECTUAL PROPERTY RIGHT.

AMBIQ MICRO DOES NOT WARRANT OR REPRESENT THAT ANY LICENSE, EITHER EXPRESS OR IMPLIED, IS GRANTED UNDER ANY PATENT RIGHT, COPYRIGHT, MASK WORK RIGHT, OR OTHER INTELLECTUAL PROPERTY RIGHT OF AMBIQ MICRO COVERING OR RELATING TO THIS CONTENT OR ANY COMBINATION, MACHINE, OR PROCESS TO WHICH THIS CONTENT RELATE OR WITH WHICH THIS CONTENT MAY BE USED.

USE OF THE INFORMATION IN THIS DOCUMENT MAY REQUIRE A LICENSE FROM A THIRD PARTY UNDER THE PATENTS OR OTHER INTELLECTUAL PROPERTY OF THAT THIRD PARTY, OR A LICENSE FROM AMBIQ MICRO UNDER THE PATENTS OR OTHER INTELLECTUAL PROPERTY OF AMBIQ MICRO.

INFORMATION IN THIS DOCUMENT IS PROVIDED SOLELY TO ENABLE SYSTEM AND SOFTWARE IMPLEMENTERS TO USE AMBIQ MICRO PRODUCTS. THERE ARE NO EXPRESS OR IMPLIED COPYRIGHT LICENSES GRANTED HEREUNDER TO DESIGN OR FABRICATE ANY INTEGRATED CIRCUITS OR INTEGRATED CIRCUITS BASED ON THE INFORMATION IN THIS DOCUMENT. AMBIQ MICRO RESERVES THE RIGHT TO MAKE CHANGES WITHOUT FURTHER NOTICE TO ANY PRODUCTS HEREIN. AMBIQ MICRO MAKES NO WARRANTY, REPRESENTATION OR GUARANTEE REGARDING THE SUITABILITY OF ITS PRODUCTS FOR ANY PARTICULAR PURPOSE, NOR DOES AMBIQ MICRO ASSUME ANY LIABILITY ARISING OUT OF THE APPLICATION OR USE OF ANY PRODUCT OR CIRCUIT, AND SPECIFICALLY DISCLAIMS ANY AND ALL LIABILITY, INCLUDING WITHOUT LIMITATION CONSEQUENTIAL OR INCIDENTAL DAMAGES. "TYPICAL" PARAMETERS WHICH MAY BE PROVIDED IN AMBIQ MICRO DATA SHEETS AND/OR SPECIFICATIONS CAN AND DO VARY IN DIFFERENT APPLICATIONS AND ACTUAL PERFORMANCE MAY VARY OVER TIME. ALL OPERATING PARAMETERS, INCLUDING "TYPICALS" MUST BE VALIDATED FOR EACH CUSTOMER APPLICATION BY CUSTOMER'S TECHNICAL EXPERTS. AMBIQ MICRO DOES NOT CONVEY ANY LICENSE UNDER NEITHER ITS PATENT RIGHTS NOR THE RIGHTS OF OTHERS. AMBIQ MICRO PRODUCTS ARE NOT DESIGNED, INTENDED, OR AUTHORIZED FOR USE AS COMPONENTS IN SYSTEMS INTENDED FOR SURGICAL IMPLANT INTO THE BODY, OR OTHER APPLICATIONS INTENDED TO SUPPORT OR SUSTAIN LIFE, OR FOR ANY OTHER APPLICATION IN WHICH THE FAILURE OF THE AMBIQ MICRO PRODUCT COULD CREATE A SITUATION WHERE PERSONAL INJURY OR DEATH MAY OCCUR. SHOULD BUYER PURCHASE OR USE AMBIQ MICRO PRODUCTS FOR ANY SUCH UNINTENDED OR UNAUTHORIZED APPLICATION, BUYER SHALL INDEMNIFY AND HOLD AMBIQ MICRO AND ITS OFFICERS, EMPLOYEES, SUBSIDIARIES, AFFILIATES, AND DISTRIBUTORS HARMLESS AGAINST ALL CLAIMS, COSTS, DAMAGES, AND EXPENSES, AND REASONABLE ATTORNEY FEES ARISING OUT OF, DIRECTLY OR INDIRECTLY, ANY CLAIM OF PERSONAL INJURY OR DEATH ASSOCIATED WITH SUCH UNINTENDED OR UNAUTHORIZED USE, EVEN IF SUCH CLAIM ALLEGES THAT AMBIQ MICRO WAS NEGLIGENT REGARDING THE DESIGN OR MANUFACTURE OF THE PART.