

LT1222 and LT1793  
 Low Noise Transimpedance Amplifier

## DESCRIPTION

Demonstration Circuit 1416 is a Low Noise Transimpedance Amplifier. It utilizes the low voltage noise LT1222 opamp, and the low current noise LT1793 opamp, along with the discrete NXP JFET BF862, allowing the user to take advantage of each component's particular optimization. These components are arranged with jump-

ers allowing various composite configurations. A socketed photodiode, OSRAM SFH213, is also provided.

**Design files for this circuit board are available. Call the LTC factory.**

 , LT, are registered trademarks of Linear Technology Corporation. Other product names may be trademarks of the companies that manufacture the products.

## PERFORMANCE SUMMARY

Specifications are typical at  $T_A = 25^\circ\text{C}$ ,  $V_S = \pm 12\text{V}$

SYMBOL	PARAMETER	CONDITIONS, COMMENTS	TYP	UNITS
$V_S$	Supply Voltage		$\pm 12\text{V}$	V
$A_Z$	TIA Gain		1M	$\Omega$
$V_{OS}$	Input Offset Voltage	LT1793 ( $V_{OS} + I_{BIAS} * 10\text{M}$ )	300	$\mu\text{V}$
$dV_{OS}/dT$	Input Offset Voltage Drift	LT1793 ( $dV_{OS}/dT + dI_{BIAS}/dT * 10\text{M}$ )	10	$\mu\text{V}/\text{C}$
$I_{BIAS}$	Input Bias Current	LT1793 + BF862	6	pA
$e_n$	Input Voltage Noise Density	$f=100\text{kHz}$ , JFET in gain configuration	1	$\text{nV}/\sqrt{\text{Hz}}$
$e_n$	Input Voltage Noise Density	$f=100\text{kHz}$ , Source follower configuration	3	$\text{nV}/\sqrt{\text{Hz}}$
$C_{in}$	Input Capacitance	$f=10\text{kHz}$ , Source follower configuration	2	pF
GBW	Gain Bandwidth Product	JP7 in ( $C_{comp} = 49\text{pF}$ )	70	MHz
GBW	Gain Bandwidth Product	JP7 out ( $C_{comp} = 10\text{pF}$ )	190	MHz
GBW	Gain Bandwidth Product	JP7 out, C7 removed ( $C_{comp}=0\text{pF}$ )	500	MHz
BW	-3dB Bandwidth	With SFH213, $1\text{M}\Omega$ Gain, JP7 out	2	MHz
$V_{OUT}$	Output Voltage Swing	Cathode input, Integrator in	0 to 10V	V
$V_{OUT}$	Output Voltage Swing	Cathode input, Integrator out	-0.4 to -10	V
$V_{OUT}$	Output Voltage Swing	Anode input, Integrator in	0 to -10V	V
$V_{OUT}$	Output Voltage Swing	Anode input, Integrator out	-0.4 to -10V	V
$I_{CC}$	Supply Current	$V_S = \pm 12\text{V}$	17	mA
$I_{BIAS}$	Input Bias Current	LT1793 + BF862	6	pA
PSRR	Power Supply Rejection Ratio	$\pm 5\text{V}$ to $\pm 15\text{V}$ , Integrator In	95	dB

## OPERATING PRINCIPLES

Composite amplifiers using single JFET inputs can be classified into two groups: common drain (or “source follower”) and common source (or “JFET in gain”). The standard jumper configuration of this board, as shipped and as indicated on the silkscreen, has the JFET as a source follower.

Another classification is DC accuracy. The LT1793 has been provided on board as an integrator to provide DC

accuracy, overriding the high 400mV or so  $V_{gs}$  of the JFET. The standard jumper configuration is “Integrator In”, so the TIA will be DC accurate to within the  $V_{os}$  of the LT1793 (900uV max). With the integrator removed from the circuit, the DC error rises to 400mV or so.

The feedback resistor, which sets the TIA gain, is 1M $\Omega$ . So the output will respond at 1V per micropamp of photocurrent.

---

## QUICK START PROCEDURE

Demonstration circuit 1416 is shipped with the jumpers set for Source Follower operation with the Integrator In. If the jumpers have been changed, restore them to the positions shown in the schematic. Refer to Figure 1 for proper measurement equipment setup and follow the procedure below:

1. With power off, connect the +12V, -12V, and Com leads from the power supply to the  $V_+$ ,  $V_-$ , and Gnd terminals of the demo circuit, as shown in Figure 1.
2. With power off, connect the  $V_{OUT}$  of the demo circuit to an oscilloscope or DMM. You can use either the gold SMA connector or the turrets provided on board, or both. Set a high range such as 2V/DIV on the oscilloscope, or Vdc on the DMM.
3. Turn on the power supply.

4. You should now be able to wave your hand over the clear Photodiode provided on the board (upper left of Figure 1) and see the effect in both DC signal and noise. With the photodiode in darkness, or removed from its socket, the output should sit near ground.
5. You can now connect an optical source to excite the photodiode in a more controlled manner. The easiest way is to drive an LED directly from a function generator, with the function generator’s internal 50 Ohm source impedance as a current limiter. Any standard color or IR LED can be used, as the Photodiode provided has a wide sensitivity. Be careful not to overdrive sensitive devices such as small lasers.
6. You can now decide whether to play with other configurations (JFET in gain, Integrator Out, more compensation, etc), or to replace the provided Photodiode with the one you intend to use.

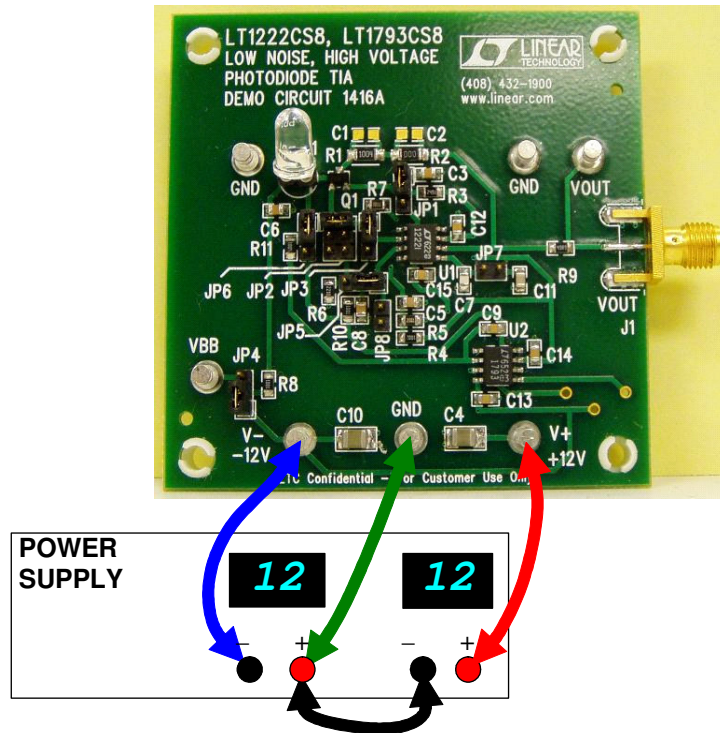

Figure 1. Proper Supply Connections. Board is shown configured for Source Follower with Integrator In. (JP1 through JP6 have shunt in position 1. JP7 and JP8 are open.)

Table 1: Jumper settings for various configurations. Refer to Figures 2 and 3 for qualitative descriptions of the configurations, and to Figure 4 for the complete schematic.

JUMPER	TYPE	CIRCUIT	SOURCE FOLLOWER INTEGRATOR IN	SOURCE FOLLOWER INTEGRATOR OUT	JFET IN GAIN INTGRTR IN	JFET IN GAIN INTGRTR OUT
JP1	1x3	JFET drain	1,2	1,2	2,3	2,3
JP2	2x3	JFET source	1,2	1,2	5,6	3,4
JP3	1x3	LT1222 -input	1,2	1,2	2,3	2,3
JP4	1x3	photodiode bias	1,2	1,2	1,2	1,2
JP5	1x3	Integrator output	1,2	out	2,3	out
JP6	1x3	Integrator Input	1,2	2,3	1,2	2,3
JP7	1x2	LT1222 compensation	out	out	in	in
JP8	1x2	LT1222 +input	out	in	out	out

# LT1222 AND LT1793

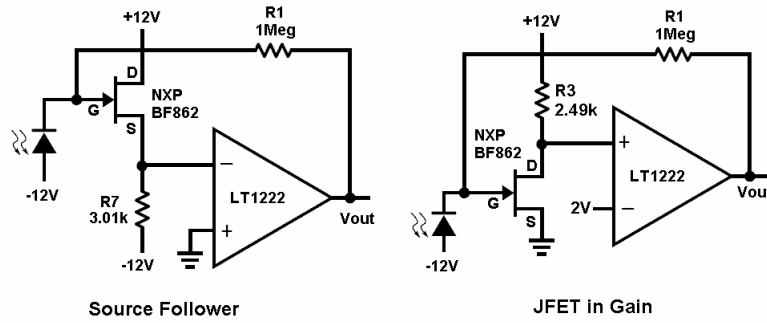

Figure 2. The two basic types of JFET configuration. The left shows the JFET as a source follower, simply buffering the feedback resistor to the opamp's inverting input. The right shows the JFET in gain, with source grounded. Because the JFET inverts, the feedback is now applied to the opamp's non-inverting input. In both cases, the effective input offset voltage is one JFET  $V_{gs}$  (about -400mV). The source follower configuration is the simplest and most versatile, but the JFET in Gain configuration offers the highest achievable gain-bandwidth product and the lowest voltage noise. Output noise at low and medium frequencies (10kHz to 100kHz) is 130nV/rtHz, dominated entirely by the feedback resistor.

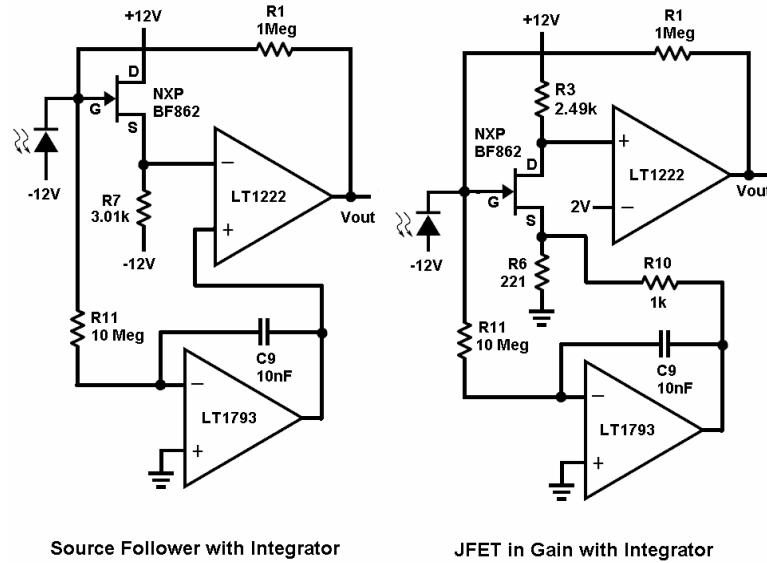
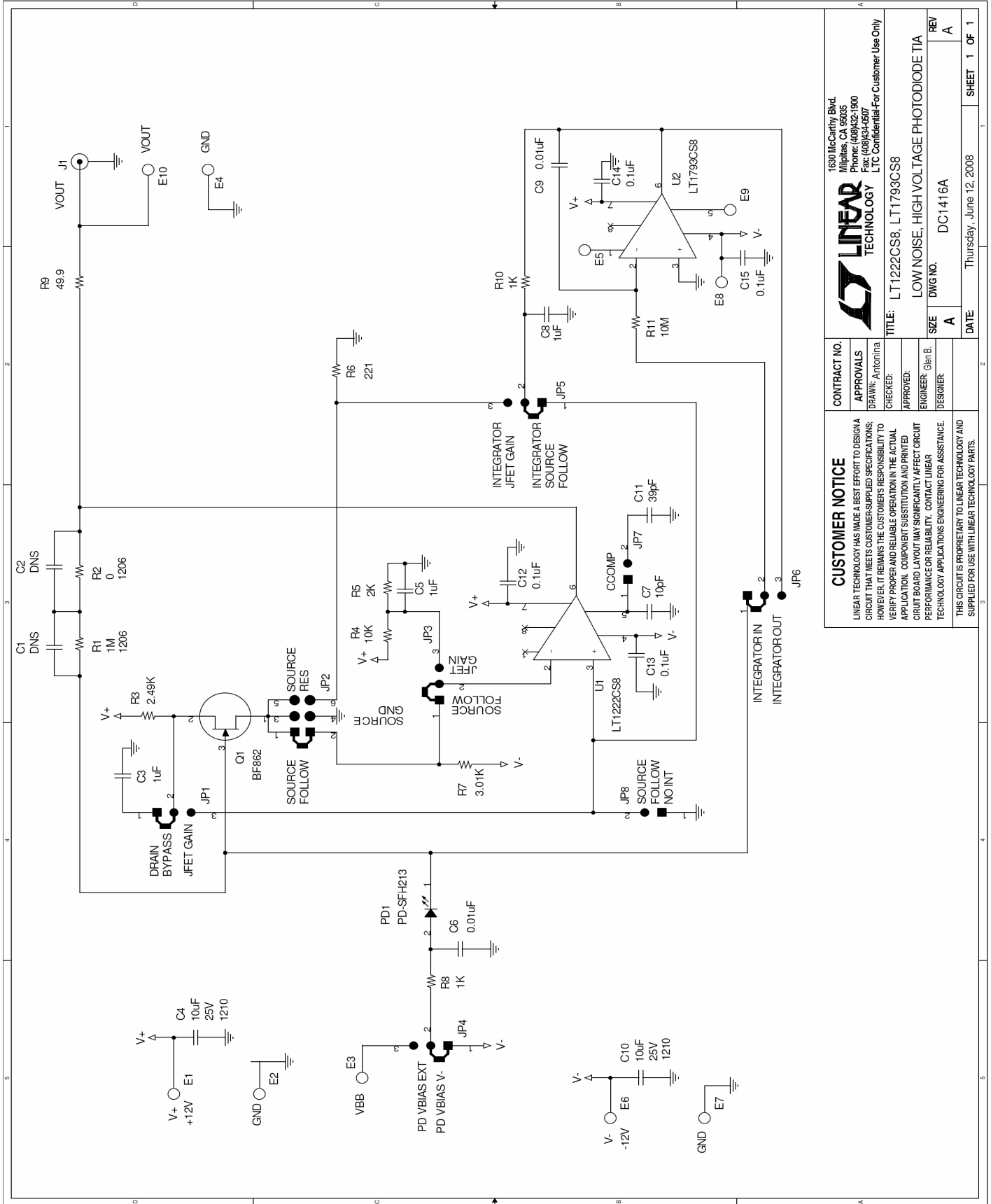

Figure 3. The two basic types of JFET configuration again, but shown with LT1793 integrators which zero out the overall input offset voltage. On the left, the JFET  $V_{gs}$  is forced to the LT1793 non-inverting input. On the right, the integrator puts JFET  $V_{gs}$  at the source directly. In both cases, the 10M sensing resistor R11 injects 40fA/√Hz of current noise, which is discernible but relatively small compared to the 130fA/√Hz of the 1M feedback resistor. The output noise at low to medium frequencies is about 136nV/√Hz.



<b>CONTRACT NO.</b>		1630 McCarthy Blvd.
<b>APPROVALS</b>		Milpitas, CA 95035
<b>DRAWN:</b>	Antoineta	Phone: (650)432-1900
<b>CHECKED:</b>		Fax: (650)934-6507
<b>APPROVED:</b>		LT Confidential For Customer Use Only
<b>ENGINEER:</b>	Glen B.	
<b>DESIGNER:</b>		
<b>TITLE:</b> LT1222CS8, LT1793CS8		
<b>LOW NOISE, HIGH VOLTAGE PHOTODIODE TIA</b>		
<b>SIZE</b>	<b>DWG NO.</b>	<b>REV</b>
A	DC1416A	A
<b>DATE:</b> Thursday, June 12, 2008		<b>SHEET 1 OF 1</b>

**CUSTOMER NOTICE**  
 LINEAR TECHNOLOGY HAS MADE A BEST EFFORT TO DESIGN A CIRCUIT THAT MEETS CUSTOMER-SUPPLIED SPECIFICATIONS; HOWEVER, IT REMAINS THE CUSTOMER'S RESPONSIBILITY TO VERIFY PROPER AND RELIABLE OPERATION IN THE ACTUAL APPLICATION. COMPONENT SUBSTITUTION AND PRINTED CIRCUIT BOARD LAYOUT MAY SIGNIFICANTLY AFFECT CIRCUIT PERFORMANCE OR RELIABILITY. CONTACT LINEAR TECHNOLOGY APPLICATIONS ENGINEERING FOR ASSISTANCE.  
 THIS CIRCUIT IS PROPRIETARY TO LINEAR TECHNOLOGY AND SUPPLIED FOR USE WITH LINEAR TECHNOLOGY PARTS.