



# Series 800 Vertisockets™

## Vertical Mounting with Collet Contacts

### FEATURES:

- Aries offers a full line of Vertisockets™ for DIP packaging of LEDs, incandescent lamps, DIP switches, test points, etc. The variations of mounting positions provide exceptional design freedom.
- Accepts standard LEDs and incandescent displays as well as .500 [21.70] and .600 [15.24] high large displays.

### SPECIFICATIONS:

- Body material is black UL 94V-0 Glass-filled 4/6 Nylon.
- Spacer is fishpaper.
- Pin body is Brass Alloy 360 1/2 hard per UNS C36000 ASTM-B16-00.
- Pin body plating is either 200µ [5.08 µm] min. 93/7 Tin/Lead per ASTM B545 or 200µ [5.08 µm] min Tin per ASTM B545 Type1 over 100µ [2.54 µm] min. Nickel per SAE-AMS-QQ-N-290.
- 4-fingered collet contact is Beryllium Copper Alloy per UNS C17200 ASTM-B194-01.
- Contact plating is 30µ [7.6 µm] min. Gold per MIL-G-45204 over 50µ [1.27 µm] min. Nickel per SAE-AMS-QQ-N-290.
- Contact current rating=3 Amps.
- Operating temperature=221°F [105°C].
- Insertion Force=180 grams/pin; Withdrawal Force=90 grams/pin; Normal Force=140 grams/pin; (based on a .018 [.46] diameter test lead).
- Accepts leads .015-.025 [.38-.64] in diameter, .110-.150 [2.79-3.81] in length.

### MOUNTING CONSIDERATIONS:

- Suggested PCB hole size=.035 ± .002 [.89 ± .05] dia.

### ALL DIMENSIONS: INCHES [MILLIMETERS]

All tolerances ± .005 [.13] unless otherwise specified

Consult factory for non-standard sizes.

Body Style	Centers "Y"	Dim. "Z"	Available Sizes
A	.200 [5.08]	.300 [7.62]	8, 10
B	.300 [7.62]	.400 [10.16]	8, 10, 12, 14, 16
B	.400 [10.16]	.500 [12.70]	8, 10
B	.600 [15.24]	.700 [17.78]	8, 10, 12, 14, 16

"W"=NO. OF PINS PER ROW X .100 [2.54]

"X"=(NO. OF PINS PER ROW - 1) X .100 [2.54]

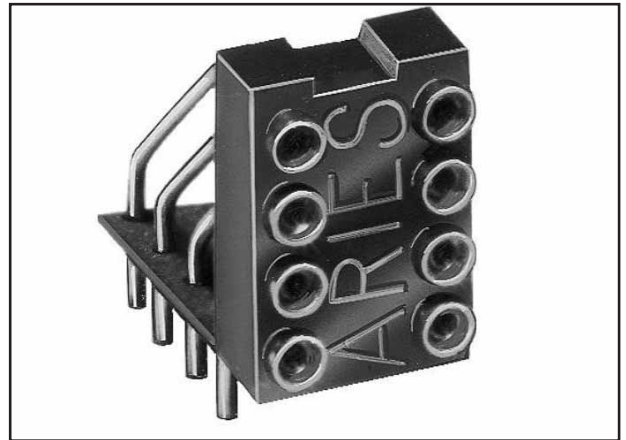
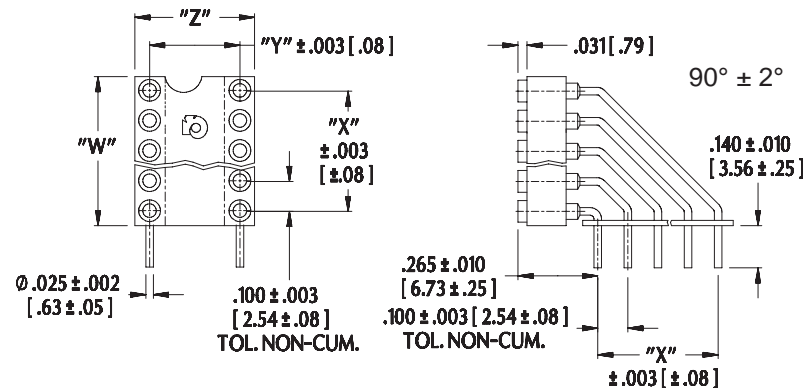

Note: Aries specializes in custom design and production. In addition to the standard products shown on this page, special materials, platings, sizes, and configurations can be furnished, depending on quantities. Aries reserves the right to change product specifications without notice.

### ORDERING INFORMATION

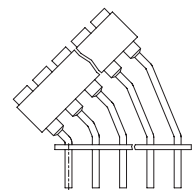
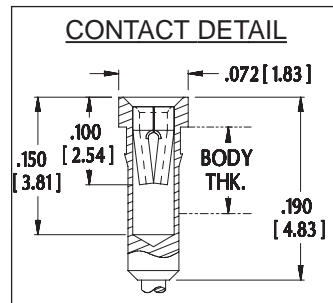
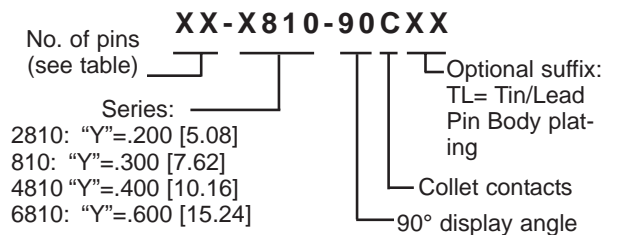

Consult factory for other display angles

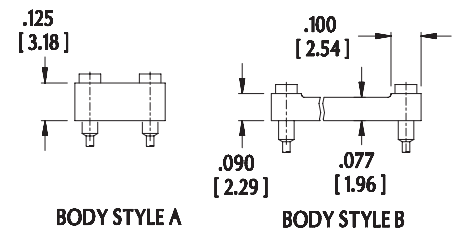

Consult Data Sheet No. 13005 for Series 800 Horizontal Mounting Vertisockets™.



http://www.arieselec.com • info@arieselec.com

NORTH AMERICA  
 Frenchtown, NJ USA  
 TEL: (908) 996-6841  
 FAX: (908) 996-3891



EUROPE  
 TEL: +44 870 240 0249  
 FAX: +44 871 919 6033  
 europe@arieselec.com



13004  
 REV.E