



Series 0517 Pin-Line Vertisockets™

FEATURES:

- For mounting components, jumpers, etc., at right angle to PC board.
- Available 1 to 25 positions; cuttable to any number desired.

SPECIFICATIONS:

- Body material is black UL 94V-0 Glass-filled 4/6 Nylon.
- Pin body is Brass Alloy 360 1/2 hard per UNS C36000 ASTM-B16-00.
- Pin body plating is either 200µ [5.08µm] 93/7 Tin/Lead per ASTM B545 or 200µ [5.08µm] min. Tin per ASTM B545 Type 1 over 100µ [2.54µm] Nickel per SAE-AMS-QQ-N-290.
- 4-fingered collet contact is Beryllium Copper Alloy per UNS C17200 ASTM-B194-01.
- Contact plating is 30µ [.76µm] Gold per MIL-G-45204 over 50µ [1.27µm] Nickel per SAE-AMS-QQ-N-290.
- Contact current rating=3 Amps.
- Operating temperature=221°F [105°C].
- Insertion Force=180 grams/pin; Withdrawal Force=90 grams/pin; Normal Force=140 grams/pin; based on a .018 [.46] diameter test lead.
- Accepts leads .015-.025 [.38-.64] in diameter, .110-.150 [2.79-3.81] long.

MOUNTING CONSIDERATIONS:

- Suggested PCB hole size=.035 ± .002 [.89 ± .05] dia.



Note: Aries specializes in custom design and production. In addition to the standard products shown on this page, special materials, platings, sizes, and configurations can be furnished, depending on quantities. Aries reserves the right to change product specifications without notice.

ORDERING INFORMATION

XX-0517-90CXX



ALL DIMENSIONS: INCHES [MILLIMETERS]

All tolerances ± .005 [.13] unless otherwise specified

"A"=NO. OF PINS X .100 [2.54]

"B"=(NO. OF PINS - 1) X .100 [2.54]

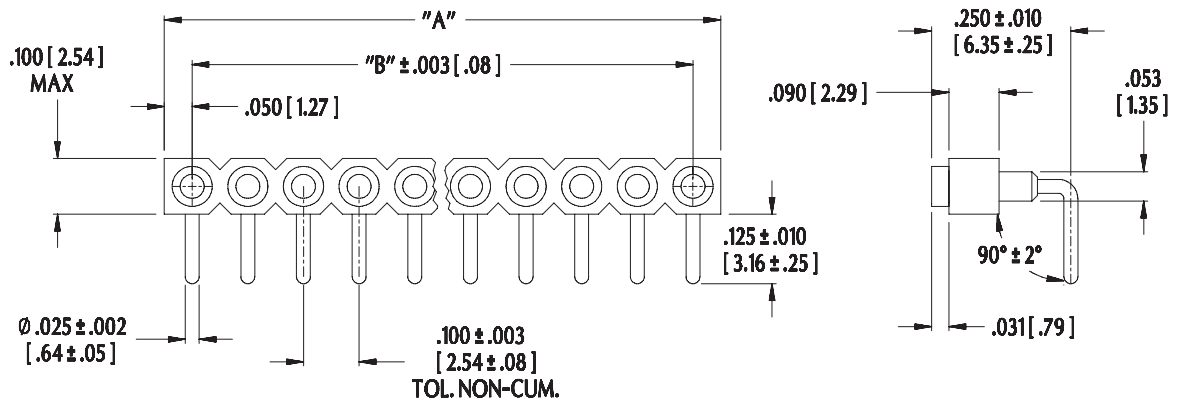
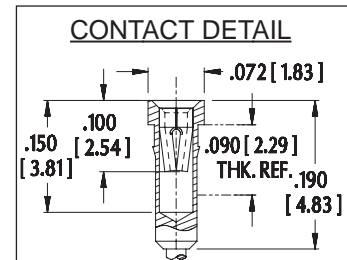

ARIES[®]
ELECTRONICS, INC.

<http://www.arieselec.com> • info@arieselec.com

NORTH AMERICA
Frenchtown, NJ USA
TEL: (908) 996-6841
FAX: (908) 996-3891



EUROPE
TEL: +44 870 240 0249
FAX: +44 871 919 6033
europa@arieselec.com



13009
REV.E