



Series C81/C91 Standard Dual Beam Wire Wrap Edge-Grip Sockets

FEATURES:

- Dual beam, edge-grip contacts provide high retention with positive wiping action.
- Removable cover provides lower profile.
- Side-to-side stackable.

SPECIFICATIONS:

- Body is black UL 94V-0 Glass-filled Thermoplastic Polyester (PBT).
- Dual beam contact is Grade A Phosphor Bronze Alloy, 1/2 hard.
- Contact plating is either 50-150 μ [1.27-3.81 μ m] min. Tin per MIL-P-81728 or 10 μ [.25 μ m] min. Gold per MIL-G-45204 over 50 μ [1.27 μ m] min. Nickel per QQ-N-290.
- Contact current rating=1.5 Amp.
- Contact resistance=20 mOhms initial.
- Insulation resistance=100 MOhms @ 500 VDC per MIL-STD-1344, method 3003.1.
- Dielectric withstanding voltage=1000 VAC.
- Operating temperature=221°F [105°C] Tin plating, =257°F [125°C] Gold plating.
- Solderability: MIL-STD-202, method 208 less heat aging.
- Accepts leads up to .011 x .018 \pm .003 [.28 x .46 \pm .08] or .021 [.53] diameter.
- Accepts leads .100-.200 [2.54-5.08] long with cover.

MOUNTING CONSIDERATIONS:

- Suggested PCB hole size=.046 \pm .002 [1.17 \pm .05] dia.

ALL DIMENSIONS: INCHES [MILLIMETERS]

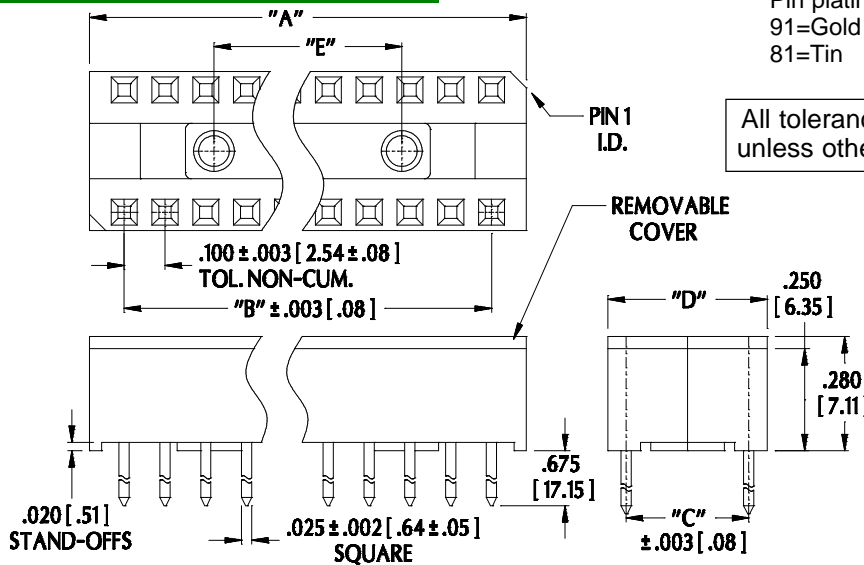

Note: Aries specializes in custom design and production. In addition to the standard products shown on this page, special materials, platings, sizes, and configurations can be furnished, depending on quantities. Aries reserves the right to change product specifications without notice.

ORDERING INFORMATION

CXXXX-XX

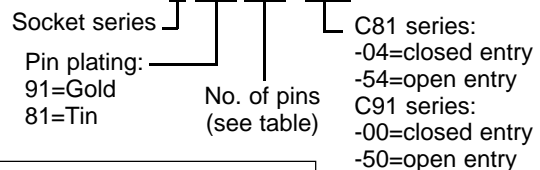

All tolerances \pm .005 [.13] unless otherwise specified

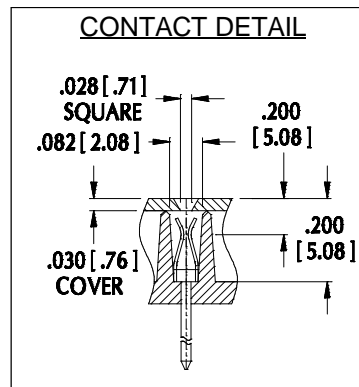

No. of Pins	Dim. "A"	Dim. "B"	Centers "C"	Dim. "D" (max)	Dim. "E"
8	.465 [11.81]	.300 [7.62]	.300 [7.62]	.400 [10.16]	---
14	.765 [19.43]	.600 [15.24]	.300 [7.62]	.400 [10.16]	.300 [7.62]
16	.865 [21.97]	.700 [17.78]	.300 [7.62]	.400 [10.16]	.400 [10.16]
18	.965 [24.51]	.800 [20.32]	.300 [7.62]	.400 [10.16]	.400 [10.16]
20	1.065 [27.05]	.900 [22.86]	.300 [7.62]	.400 [10.16]	.400 [10.16]
22	1.180 [29.97]	1.000 [25.40]	.400 [10.16]	.500 [12.70]	.500 [12.70]
24	1.280 [32.51]	1.100 [27.94]	.600 [15.24]	.700 [17.78]	.500 [12.70]
28	1.480 [37.59]	1.300 [33.02]	.600 [15.24]	.700 [17.78]	.500 [12.70]
36	1.880 [47.75]	1.700 [43.18]	.600 [15.24]	.700 [17.78]	.800 [20.32]
40	2.080 [52.83]	1.900 [48.26]	.600 [15.24]	.700 [17.78]	.800 [20.32]

ARIES
ELECTRONICS, INC.
<http://www.arieselec.com> • info@arieselec.com

NORTH AMERICA
Frenchtown, NJ USA
TEL: (908) 996-6841
FAX: (908) 996-3891



EUROPE
TEL: +44 870 240 0249
FAX: +44 871 919 6033
europe@arieselec.com

12003
REV.B