

BOS1901 Development Kit

1 Features

- Plug and play development kit to experience piezo haptic feedback
- Low-power BOS1901 integrated circuit, high voltage driver with digital interface
- Simple power interface for development via USB port
- Standard USB audio to prototype haptic effects in MATLAB®, Python®, Audacity® and many other softwares¹
- Fully embeddable modular software driver
- Easy generation of high-voltage waveforms up to 190 Vpp
- Two breakable miniature PCBs with BOS1901 drivers
- Standard commercial piezo actuators included in the Kit:
 - Starter Set: TDK PowerHap™ 1204² lateral
 - Premium Set: TDK PowerHap™ 1204 lateral, 0904 lateral, 0909 square, Midé Technology PPA-2014 bending.

2 Description

The BOS1901-KIT is a Development Kit to help users who want to get familiarized with the BOS1901 Piezo Haptic Driver IC.

The USB powered kit appears as an USB Audio device for the computer, which allows the rapid generation of waveforms using existing audio software like Audacity® for haptic prototyping.

Each breakable miniature PCB gives access to all signals allowing the user to experiment with the BOS1901 using a development platform of his/her choice.

Standard commercial piezo actuators are provided as a starting point to begin experiencing with haptic feedback.

Table 1: Ordering information

PRODUCT	DESCRIPTION
BOS1901-KIT-A	Premium Set with Four Actuators
BOS1901-KIT-B	Starter Set with One Actuator

For details see section 2

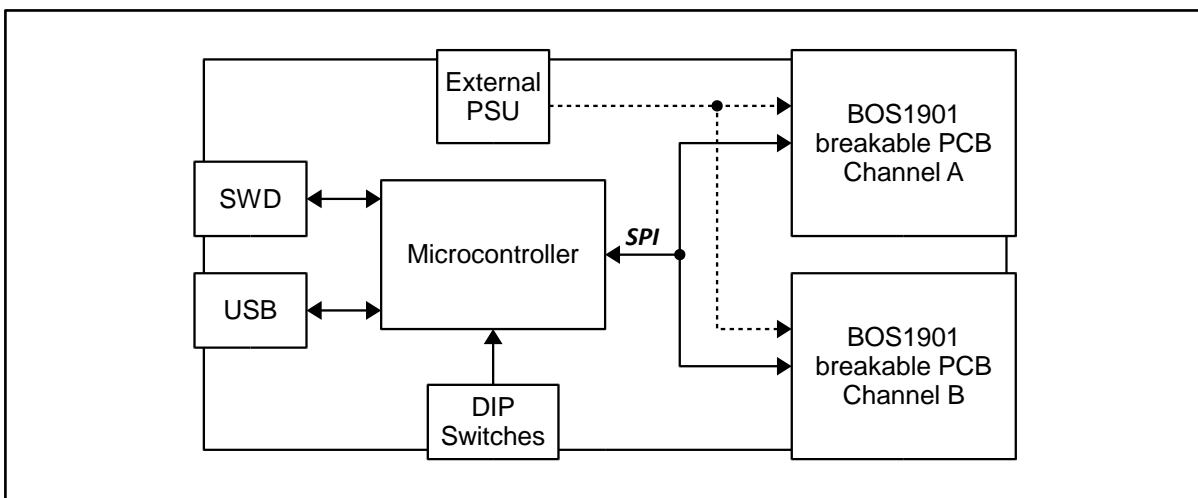

Figure 1: Simplified BOS1901-KIT diagram

¹ MATLAB® is registered trademark of The MathWorks, Inc.
Python® is a registered trademark of the PSF

² PowerHap™ is a trademark of TDK Corporation
Audacity® is a registered trademark of Dominic Mazzoni

3 Quick-Start guide

3.1 What's in the Box

The BOS1901-KIT is currently available in two distinct packages: *Premium Set* and *Starter Set*. The following tables show the content of each set.

Table 2: **Premium Set BOS1901-KIT-A** development kit content









#	ITEM	DESCRIPTION	REFERENCE
1	Evaluation PCB	BOS1901 Evaluation PCB	
2	USB Cable	Cable to connect the evaluation PCB to a computer Stewart Connector part number SC-2AMK001F	
3	TDK Piezo Actuator	TDK Mini PowerHap™ 1204H018V060 (4.5G) Actuator Ordering : Z63000Z2910Z 1Z 39 Capacitance : 0.42 µF Dim : 12.0 x 4.0 x 1.8 mm	
4	TDK Piezo Actuator	TDK Mini PowerHap™ 0904H014V060 (3.0G) Actuator Ordering : Z63000Z2910Z 1Z 41 Capacitance : 0.32 µF Dim : 9.0 x 3.75 x 1.4 mm	
5	TDK Piezo Actuator	TDK PowerHap™ 0909H011V060 (2.5G) Actuator Ordering: B54103H2020A001 (Z63000Z2910Z 1Z 2) Capacitance : 0.85 µF Dim : 9.0 x 9.0 x 0.55 mm	
6	Midé Piezo Actuator	Midé PPA-2014 (S233-H5FR-1107XB) Flex with 4-to-2 connector, Clamp M3 x 0.3 mm thread hex nuts 6 mm low-profile socket head screws. <i>Refer to section 4.2.3 for clamp assembly instructions.</i>	
7	Power Connector	Connector and cable for external power supply connection (refer to section 4.1.1) JST Sales America Inc. part numbers PHR-2 and ASPHSPH24K51	

Table 3: **Starter Set BOS1901-KIT-B** development kit content

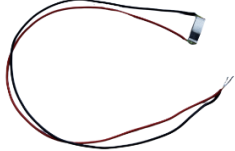
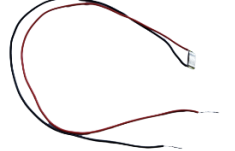
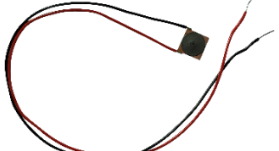
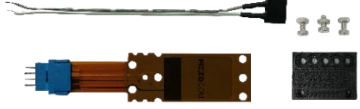
#	ITEM	DESCRIPTION	REFERENCE
1	Evaluation PCB	BOS1901 Evaluation PCB	
2	USB Cable	Cable to connect the evaluation PCB to a computer Stewart Connector part number SC-2AMK001F	
3	TDK Piezo Actuator	TDK Mini PowerHap™ 1204H018V060 (4.5G) Actuator Ordering : Z63000Z2910Z 1Z 39 Capacitance : 0.42 μ F Dim : 12.0 x 4.0 x 1.8 mm	
4	Power Connector	Connector and cable for external power supply connection (refer to section 4.1.1) JST Sales America Inc. part numbers PHR-2 and ASPHSPH24K51	

3.2 PCB Overview

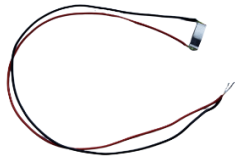
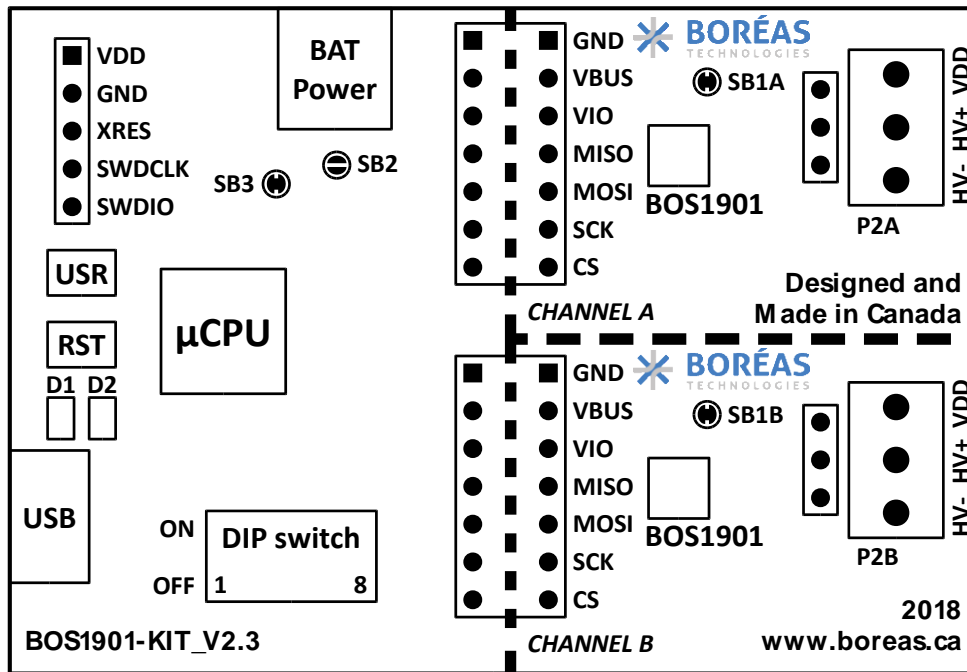

Figure 2: BOS1901-KIT Evaluation PCB overview

3.3 Quick-Start Procedure











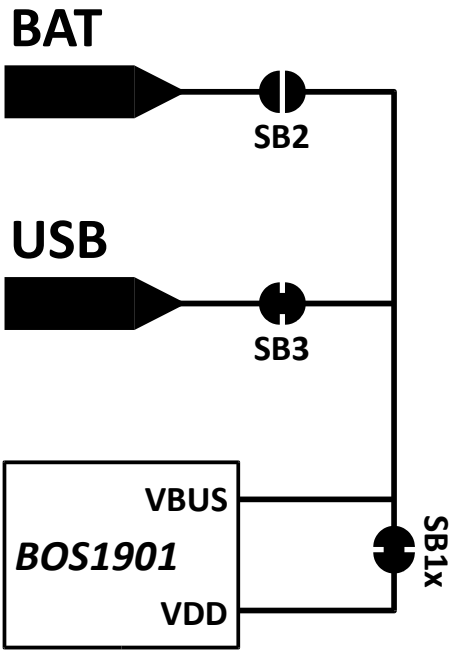

1. Refer to sections 4.1 for jumper options and 4.2 for switch settings to insure the evaluation PCB is in the intended settings.
2. Connect the selected actuator to channel A on P2A connector (refer to sections 4.2 and 4.4). We recommend securing the actuator on a flat surface using electrical insulation tape to avoid touching exposed connections and improve the feedback sensation.
3. Connect the evaluation PCB to a computer using the included USB cable, then wait for LED D1 (green) to light up and LED D2 (red) to turn and stay off, after the firmware identification sequence (see section 6.1).
4. Push the sensor with a finger to feel the feedback. Enhance the feedback experience by changing DIP switch settings (refer to section 4.2). With switches 5, 6 and 7 all set to OFF the "click" might be too subtle. Turn all switches 5, 6 and 7 to ON and then push the piezo again; the feeling should be clearer. Try various settings for switches 5 to 7 and see how it affects the feedback.
5. Plug the piezo into channel B and set SW3 to ON and SW4 to ON. Gradually apply pressure on the piezo, 3 events can be felt: 1 click, then a stronger click, and then a buzz. If it is difficult to distinguish all 3 events, set SW7 OFF to decrease the sensitivity.
6. Using the Audacity® software (refer to section 5.2), select a waveform to play on the actuator.

4 Hardware

4.1 Jumper Options

The BOS1901-KIT is provided by default with jumpers SB2, SB3 and SB1X set to operate from USB power, UPI mode off.

Table 4: Jumper options

Function	Shorts	HW
USB Power	SB2 	
UPI OFF	SB3 	
(default)	SB1x 	
USB Power	SB2 	
UPI ON*	SB3 	
	SB1x 	
BAT Power	SB2 	
UPI OFF	SB3 	
	SB1x 	
BAT Power	SB2 	
UPI ON*	SB3 	
	SB1x 	

* Refer to section 4.1.2 for more details and limitations.

4.1.1 Using BAT Power (external power supply connection)

From default state:

1. Remove power to the evaluation PCB by unplugging the USB cable.
2. Cut junction of SB3 jumper. Verify it is well-disconnected using a multimeter.
3. Put a solder joint on SB2. Verify the new connection using a multimeter.
4. Optional, solder a capacitor on C19 if additional decoupling is required on VBUS node.
5. Plug the USB cable to the evaluation PCB for power and communication to the microcontroller section.
6. Apply an external DC source ranging from 3 V to 5 V on connector P5 using the provided power connector (item # 5 in Table 2: Premium Set (BOS1901-KIT-A) development kit content).
7. Push and release "RST" button (S2), then wait for green LED to light up and for red LED to turn and stay off, after the firmware identification sequence (see section 6.1).

Note: the "USR" button (S1) has reserved usage on the current firmware.

4.1.2 Using UPI Feature

WARNING - With UPI enabled, the energy recovery feature of the BOS1901 will accumulate energy on C1A/C1B capacitor, causing VDD voltage to increase. The user should make sure that VDD voltage never exceeds the 5.5 V limit otherwise it may permanently damage the BOS1901. For instance, due to its larger capacitance, it is not recommended to use the PowerHap™ 2.5G actuator with 5 V supply and UPI feature ON. When using this feature with piezo devices other than those provided in the kit, make sure to size C1A/C1B accordingly. Please refer to BOS1901 datasheet section 6.2.10 for more details.

From default state:

1. Remove power to the evaluation PCB by unplugging the USB cable.
2. Remove solder joint on one or both SB1X, depending on the choice of UPI configuration. Verify the disconnection using a multimeter.
3. Plug the USB cable to the evaluation PCB, wait for green LED to light up and for red LED to turn and stay off, after the firmware identification sequence (see section 6.1).

4.2 Piezo Actuators

One TDK actuator is provided with the BOS1901-KIT **Starter Set** and four with the **Premium Set**, one from Midé and the others from TDK.

4.2.1 Midé Actuator

Midé PPA-2014 Flex piezo actuator specifications:

Type	Bender
Polarity	None, can be connected on either side using the provided 4-to-2 connector
Range	Full-scale -95 V to +95 V, use with switch SW1 at "ON" position (refer to section 4.3)

4.2.2 TDK Actuator

TDK PowerHap™ 2.5G piezo actuator specifications:

Type	Cymbal design
Polarity	Red wire on "HV+" terminal Black wire on "HV-" terminal
Range	Unipolar -10 V to +60 V, use with switch SW1 at "OFF" position (refer to section 4.3)

TDK Mini PowerHap™ 1204H018V060 specifications:

Type	Cymbal design
Polarity	Red wire on "HV+" terminal Black wire on "HV-" terminal
Range	Unipolar -10 V to +60 V, use with switch SW1 at "OFF" position (refer to section 4.3)

TDK Mini PowerHap™ 0904H014V060 specifications:

Type	Cymbal design
Polarity	Red wire on "HV+" terminal Black wire on "HV-" terminal
Range	Unipolar -10 V to +60 V, use with switch SW1 at "OFF" position (refer to section 4.3)

It is of utmost importance to not use the TDK PowerHap™ actuators in Full-scale mode as it can get damaged unless the waveform is properly designed to limit the output voltage between -10 V and +60 V. Example waveforms are provided on Boréas website (www.boreas.ca/bos1901-kit).

Refer to section 4.4.2 for a special output configuration, in which two TDK actuators can be connected on a single BOS1901 circuit:

- "Load 1" with red wire connected to "HV+" and black wire on "VDD"
- "Load 2" with red wire connected to "HV-" and black wire on "VDD"
- Use of Unipolar mode with output voltage limited to +60 V (SW1 set to OFF)
- Toggle SW2 to single ended mode (ON)

4.2.3 Midé Actuator Clamp Assembly Instructions

The Midé actuator must be assembled the provided clamp to be operated properly. Follow the instructions below to assemble the clamp on the actuator.

1. Take Midé actuator, black clamp, screw and nuts, and 4-to-2 connector.
2. Separate the clamp in two parts. Place the actuator inside the clamp with the rigid actuator part on the side with 5 holes and the flexible ribbon and blue connector on the side with only 2 holes. Make sure the middle hole of the actuator is aligned with the middle hole of the clamp.

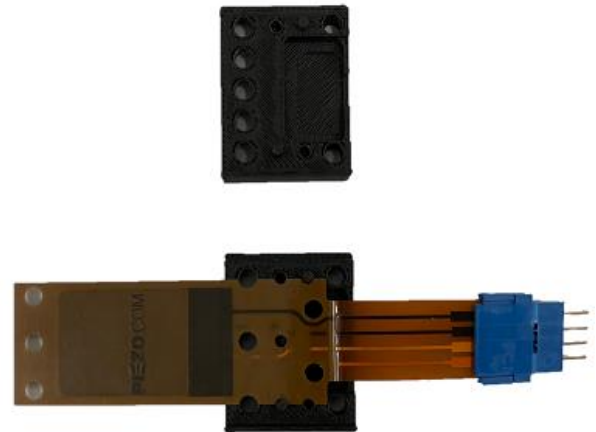
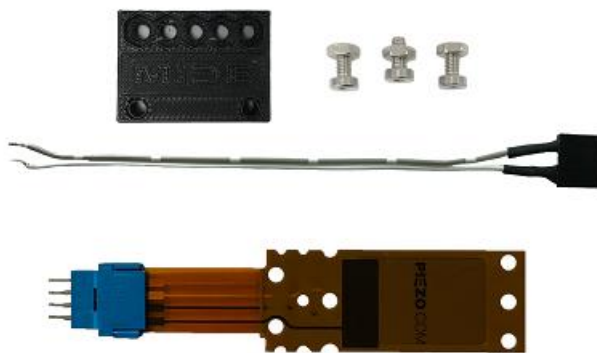

3. Use 3 screws and 3 nuts to fix the assembly.
4. To feel the actuator feedback, just touch the rigid part. To activate the click detection, hold the clamp in place and gently press on the actuator rigid part. If the click feedback is not felt, flip the entire assembly upside down.

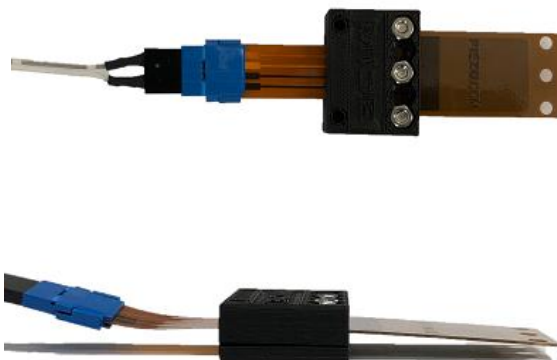

Figure 3 Midé actuator clamp assembly instructions

4.3 DIP Switch Settings

The evaluation PCB is provided by default with S3 DIP Switch set to Unipolar operation with only Channel A enabled. It is recommended to toggle these switches only while not playing waveforms.

Table 5: S3 DIP switch settings

DEFAULT	SWITCH	OFF	ON
OFF	SW1	Unipolar (-10 V/+60 V)	Full-scale (-95 V/+95 V)
OFF	SW2	Differential out config*	Single ended config*
OFF	SW3	Only channel A ON	Both channels ON
OFF	SW4	Press-release feedback on channel B	Multipress feedback on channel B
OFF	SW5	100 Hz feedback	180 Hz feedback
OFF	SW6	75 % amplitude feedback	100 % amplitude feedback
OFF	SW7	Low sensitivity feedback	High sensitivity feedback
OFF	SW8	Not used	Not used

* Refer to section 4.4 for more details on output configurations

SW1 The output ranges listed for SW1 settings are for full amplitude input signal, for example -1 to +1 when using Audacity® software (refer to section 5.2). When using Midé PPA-2014 Flex piezo actuator, set SW1 to ON. When using TDK PowerHap™ piezo actuator, set SW1 to OFF.

More precisely, this switch sets the maximum and minimum values allowable for the selected range. It does not affect the gain and offset conversion between the input signal and the output voltage. If the requested voltage is out the range, the firmware will clip the signal to the limits of the range. Therefore, a single conversion equation is used for the same voltage in both ranges. The relation between the input signal value and the output voltage is:

$$Signal = \frac{Voltage}{95 V}$$

Thus signals of +1, -1 and 0 correspond to 95 V, -95 V and 0 V respectively. To generate a 60 V output, the signal should be 60 V/95 V = 0.631.

SW2 Refer to section 4.4 for configuration details. Sensing is not possible in single-ended configuration.

SW3 SW3 determines how many channels are active. Set SW3 to OFF to activate only channel A. Set SW3 to ON to activate both channels. When a channel is activated it can sense pressure and give feedback, and it can play waveforms.

SW4 When both channels are active (SW3 is ON), set SW4 to OFF to have both channels feedback a single click. Setting SW4 to ON will maintain channel A to feedback single clicks but channel B will give three feedback response levels depending on the exerted pressure. A low-level

pressure triggers a single light click, medium pressure triggers a stronger click, and a high pressure triggers a longer feedback.

- SW5 SW5 sets the frequency of the feedback response when the actuator is pressed and released.
- SW6 SW6 sets the amplitude level of the feedback response. Setting SW6 to ON will provide a stronger response than setting it to OFF. SW6 has an effect only in press-release mode.
- SW7 SW7 sets the sensitivity level for feedback. Setting SW7 to ON will require less pressure to trigger the feedback.
- SW8 SW8 is not used in the current firmware. It could be used in firmware created by the user.

Setting SW5, SW6 and SW7 to ON will maximize the feedback response.

4.4 Output Configuration Options

With the two-terminal differential output, two outputs configurations are possible to drive a piezo.

4.4.1 Differential Output Configuration

The typical output configuration is the differential output, refer to Figure 4. The piezo-element is driven with one terminal connected to "HV+" and the other connected to "HV-". This configuration can achieve a differential output voltage of 190 Vpp in Full-scale mode.

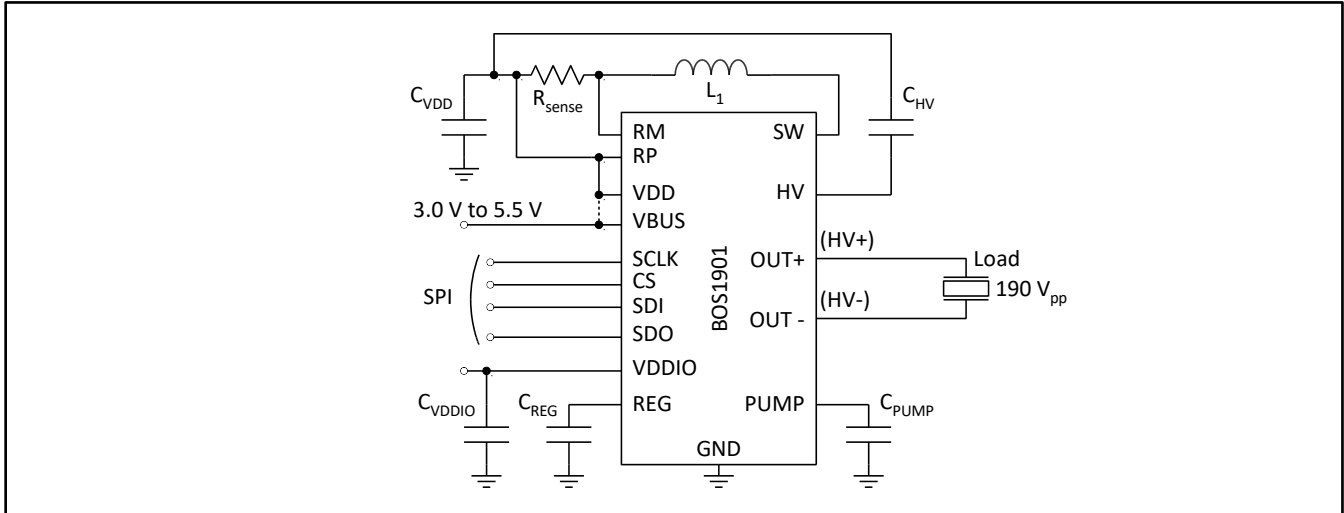

Figure 4: Two-terminal differential output configuration

4.4.2 Single-Ended Output Configuration

The single ended output configuration allows to drive up to two different piezo elements, see Figure 5. A piezo element is driven with one terminal connected to "HV+" or "HV-" and the other connected to "VDD". This configuration can achieve a single ended output voltage of 95 V. Only one piezo element can be driven at a time based on signal polarity.

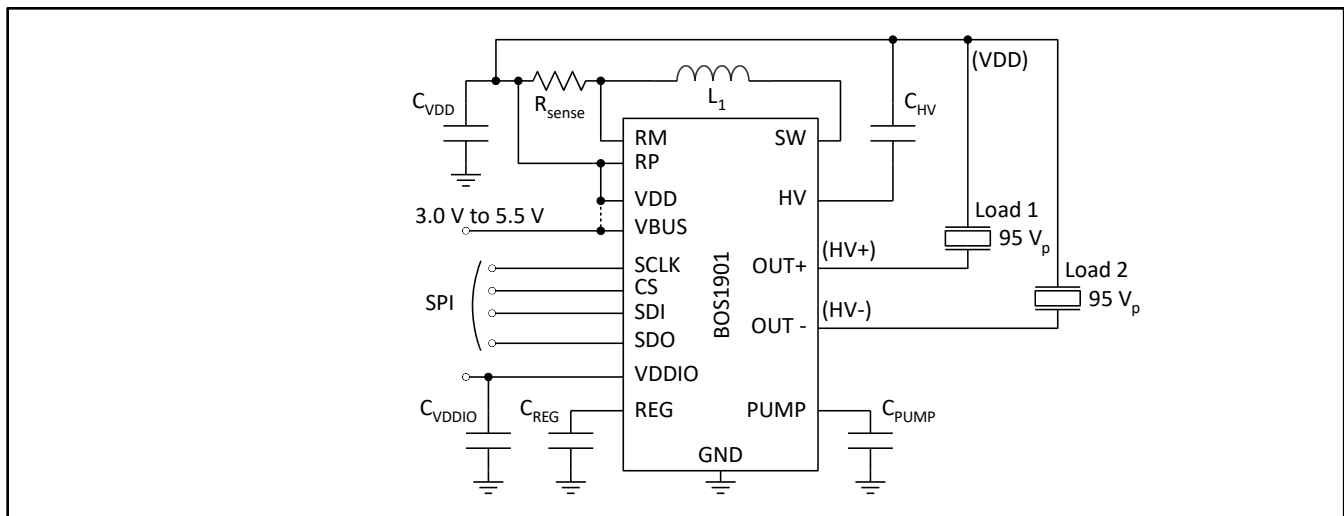

Figure 5: Two-terminal single-ended output configuration

4.5 Breakable Units

The use of the breakable units with custom-made firmware is done at the user's own risk of causing damage beyond repair to the BOS1901 circuit. Boréas Technologies will not be held responsible.

Each channel is on a breakable PCB unit that can be used alone with a user-preferred development platform. The available signals are:

- GND 0 V reference
- VDD Main power supply for the BOS1901 (from 3 V to 5 V)
- VIO Digital IO power supply (set to SPI signals voltage level, between 1.8 V and 5 V)
- MISO SPI Master In/Slave Out signal
- MOSI SPI Master Out/Slave In signal
- SCK SPI Clock signal
- CS SPI Chip Select signal (active low)

Refer to BOS1901 datasheet for a complete description on how to use and program the circuit.

5 Software

5.1 Software Installation Procedure

Please follow the Audacity® installation procedure. The software is free of use and can be found at: <https://www.audacityteam.org/download/>.

Refer to <https://www.audacityteam.org/about/license/> for the terms of GNU General Public License (GPL) for Audacity® use.

5.2 Software Operation

The evaluation PCB appears as a speaker to the computer. The following operation example is made using Audacity® software, but the use of any other software is also possible. Make sure the USB audio firmware is installed on the evaluation PCB, refer to section 6.1 for firmware installation/update procedure.

1. Connect the evaluation PCB with the USB cable, wait for green LED to light up and for red LED to turn and stay off, after the firmware identification sequence (see section 6.1).
2. Start Audacity®, then select "File/Open..." to load "Audacity project - BOS1901-KIT.aup" file available for download on [Boréas website](#).
3. Select the appropriate Audio Host (see Figure 6):
 - For Windows: select "Windows Direct Sound"
 - For MAC OS X: select "Audio Core"
 - For Linux: select "ALSA"
4. Select "Cypress Digital Audio" as the Playback Device (see Figure 6).
5. Press play button to start the default 100 Hz sine waveform, which will play for 5 seconds.

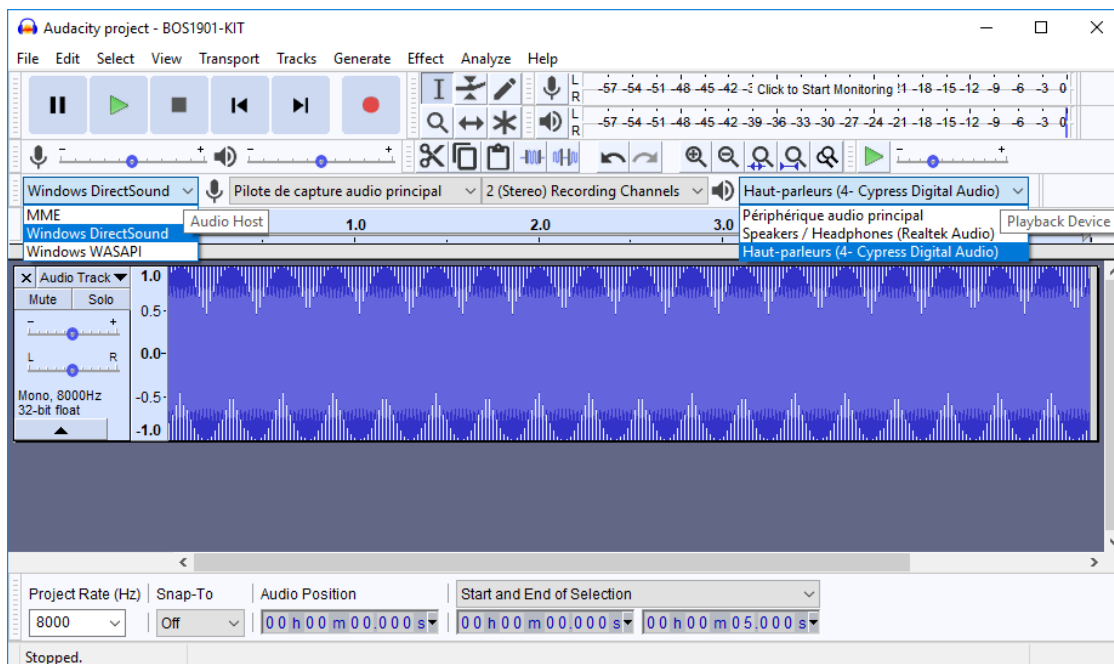

Figure 6: Audacity® software interface

6. The balance between channels A and B can be changed using the "L/R" dial in the "Audio Track" field, "L" corresponding to channel A, "R" to channel B. The gain can also be changed with "-/+" dial, but beware of positive gains that may cause output clipping.
7. To generate another kind of waveform, change its frequency or amplitude, go to the "Generate/Tone..." menu. For Square and Sawtooth, it is possible the software will calculate points based on an 8 kHz filter, therefore distorting the output waveform. To offset the waveform, an effect called ["DC offset"](#) may be applied, but it must be installed first. Instructions on how to install plugins are given on the [Audacity® website](#).
8. Existing or generated .wav files can be played with Audacity®, loaded with the "File/Open..." dialog.
9. If starting a new project, make sure to use a Project Rate at 8 kHz (lower left corner field).
10. For other Audacity® features, please refer to the software help.

6 Firmware

6.1 Identifying the Firmware Revision Number

Since firmware revision 2.2, when powering up the development kit, both LEDs will show the firmware revision number and then the IC revision.

After the 10-second bootload window while both LEDs are on (see next section), the green and red LEDs flash to indicate the firmware revision number. For a firmware revision X.Y with major revision X and minor revision Y, the green LED will flash X times and then the red LED will flash Y times. This sequence is repeated for a beta revision.

Then both LEDs are lit a short while as some initialization is performed, and then ICs are identified. Green LED will flash to indicate channel A BOS1901 IC revision, and red LED will flash to indicate channel B BOS1901 IC revision. For each channel, the LEDs will flash 1, 2 or 3 times to indicate the IC for that channel is of revision A, B or C respectively.

6.2 Firmware Installation/Update Procedure

The BOS1901-KIT is provided out-of-the box with a firmware for use as an USB Audio device.

This firmware can be changed and/or updated using the USBBootloaderHost.exe application available on Boréas website. The procedure is the following:

1. Load the appropriate *.cyacd file using the "Load File" button.
2. Press and release the "RST" button on the evaluation PCB . When the "USB HID State" field reads "Connected", press on "Program" button. Note that the evaluation PCB will stay connected for only 10 seconds; the "Program" button must be pressed within that time. After this delay, red LED turns off, the firmware identification sequence occurs and then the evaluation PCB enters normal operation. If the "USB HID State" field does not read "Connected", press on "RST" button and try again.
3. Wait for installation/update to finish, the "Status Log" field will inform of a successful firmware installation.
4. Once the installation is complete, LEDs will go through the firmware identification sequence given in the previous section, and end with green LED on and red LED off. If red LED does not turn off, wait a couple of seconds then press and release "RST" again.

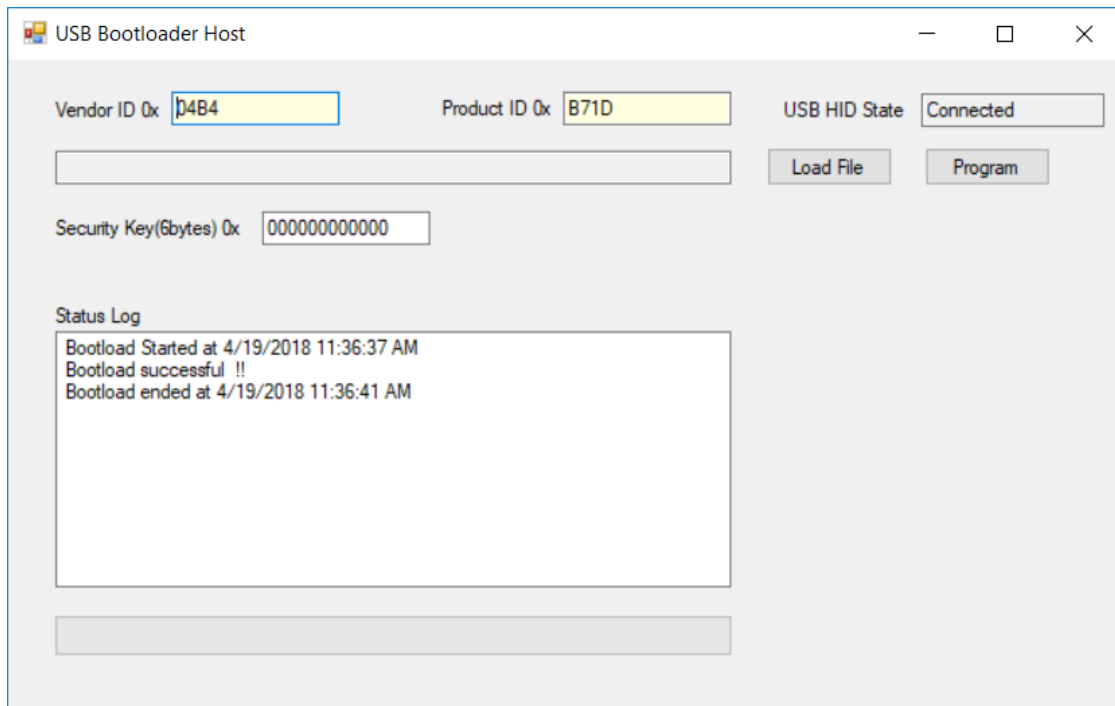

Figure 7: USBBootloaderHost.exe interface for firmware installation/update

6.3 Firmware Modification - Using PSoC[®] Creator™³

Firmware modification by the user will not be supported by Boréas Technologies. It is done at the user's own risk of causing damage beyond repair to the BOS1901. This section only presents a starting point for any user who may want to modify the firmware. A careful read of the BOS1901 datasheet is strongly recommended before doing so.

The firmware source code is available for download on [Boréas website](#). PSoC[®] Creator™ IDE is available for download at <http://www.cypress.com/products/psoc-creator-integrated-design-environment-ide>.

The procedure for first firmware compilation is:

1. Start PSoC[®] Creator™, then go to "File/Open/Project" and select the file "PSoCCreator.cywrk" (make sure to start with the latest project file).
2. In the "Workspace Explorer", right-click on "Project 'USBFS_Bootloader'" then choose "Build USBFS_Bootloader".
3. In the "Workspace Explorer", right-click on "Project 'BOS1901_Test'" then choose "Build BOS1901_Test".
4. The compiled firmware BOS1901_Test.cyacd will be in the folder:
Project name\BOS9101_Test.cydsn\CortexM3\ARM_GCC_541\Debug\
5. Update the firmware using the procedure presented in section 6.2.

After any code modification, repeat steps 3 to 5 to test.

It is highly recommended to use a Cypress MiniProg3 (CY8KIT-002) when modifying the source code. This inexpensive kit allows to program the PSoC[®] microcontroller directly from PSoC[®] Creator™ through the SWD connector on the board. It also enables to enter debug mode and save valuable time in producing bug-free code.

Board resources can be used in modified code. DIP switch 8 is not used and can be programmed by the user. Other DIP switches, USR button, and LEDs can all be reprogrammed if the associated code is adjusted accordingly.

Unused PSoC[®] I/Os can be activated to expand user-specific application code; wires can be soldered on them if necessary. PSoC[®] internal components such as ADCs and EEPROM memory may also be used.

³ PSoC[®] is a registered trademark of Cypress Semiconductor Corporation
PSoC[®] Creator™ is a trademark of Cypress Semiconductor Corporation

6.4 Adjusting Sensing Feedback Parameters via Firmware Modification

The BOS1901-KIT is provided out-of-the box with a firmware that allows sensing feedback to be experienced (see section 3.3). S3 DIP Switches SW4 to SW7 can be used to toggle the sensing feedback parameters between preset values (see section 4.3). Finer adjustment of the sensing feedback parameters is done by firmware modification or using the GUI available for download on our website, refer to section 7 for more details. The following sections explain how to change the settings of each DIP Switch state by modifying the firmware source code.

6.4.1 Sensing Feedback Amplitude

Do not put values higher than 1.0 for any of those variables or it will permanently damage the piezo. These variables only have an effect when in TDK mode (SW1 OFF).

1. In PSoC[®] Creator™, go to project "BOS1901_Test", then go to folder "Header Files" and open file "sensing_button_data.h".
2. Edit the #define variables values in section "Amplitude variables".
 - LOW_AMP_MULTIPLICATOR changes the high-low amplitude ratio.
 - HIGH_AMP_PRESS_FEEDBACK_TDK_CIRC changes the press feedback intensity.
 - When SW6 is ON, the feedback amplitude is set to HIGH_AMP_PRESS_FEEDBACK_TDK_CIRC.
 - When SW6 is OFF, the feedback amplitude is set to LOW_AMP_MULTIPLICATOR times HIGH_AMP_PRESS_FEEDBACK_TDK_CIRC.
 - HIGH_AMP_RELEASE_FEEDBACK_TDK_CIRC changes the release feedback intensity.
 - When SW6 is ON, the feedback amplitude is set to HIGH_AMP_RELEASE_FEEDBACK_TDK_CIRC.
 - When SW6 is OFF, the feedback amplitude is set to LOW_AMP_MULTIPLICATOR times HIGH_AMP_RELEASE_FEEDBACK_TDK_CIRC.
3. Save and build the project, and then upload the new firmware as explained in section 6.2 or using a MiniProg3.

6.4.2 Sensing Feedback Frequency

Do not put values higher than 300 for any of those variables or it will permanently damage the piezo.

1. In PSoC[®] Creator™, go to project "BOS1901_Test", then go to folder "Header Files" and open file "sensing_button_data.h".
2. Edit the #define variables values in section "Frequency variables".
 - SENSING_FEEDBACK_FREQ_DEFAULT_LOW changes the low feedback signal frequency (SW5 is OFF).
 - SENSING_FEEDBACK_FREQ_DEFAULT_HIGH changes the high feedback signal frequency (SW5 is ON).
3. Save and build the project, and then upload the new firmware as explained in section 6.2 or using a MiniProg3.

6.4.3 Sensing Threshold

These variables only have an effect when in TDK mode (SW1 OFF).

1. In PSoC® Creator™, go to project "BOS1901_Test", then go to folder "Header Files" and open file "sensing_button_data.h"
2. Edit the #define variables values in section "Threshold variables".
 - HS_TRESH_TDK_CIRC changes the high sensitivity threshold (SW7 is OFF).
 - LS_TRESH_TDK_CIRC changes the low sensitivity threshold (SW7 is ON).
3. Save and build the project, and then upload the new firmware as explained in section 6.2 or using a MiniProg3.

6.4.4 Response Type

1. In PSoC® Creator™, go to project "BOS1901_Test", then go to folder "Header Files" and open file "sensing_button_data.h"
2. Edit the #define variables values in section "Response type".
 - RESPONSE_TYPE_CLICK_PRD changes number of sine wave period on single click feedback (press-release feedback on both channels, low and medium pressure of multipress feedback on channel B).
 - RESPONSE_TYPE_LONG_PRD changes number of sine wave period on long feedback (high pressure of multipress feedback on channel B).
3. Save and build the project, and then upload the new firmware as explained in section 6.2 or using a MiniProg3.

Note: Since firmware v2.3, the “USR” button is used to return all parameters programmed using BOS1901-KIT Controller GUI software to their default value.

7 BOS1901-KIT Controller (GUI)

BOS1901-KIT Controller is a graphical user interface intended to ease evaluation of the BOS1901 IC using BOS1901-KIT development kit. Using this application, all functionalities specific to the BOS1901 IC and BOS1901-KIT are configurable, giving the user direct control over the behaviour of the driven piezoelectric actuator, without the need to modify the firmware source code. It is intended as a first step in evaluating the BOS1901 IC, before getting into system-specific SPI interfacing.

The GUI installer is available for download on [Boréas website](#). Any advices on the installation procedure and on how to use it will be found in the BOS1901-KIT Controller (GUI) – User Guide also provided on the website.

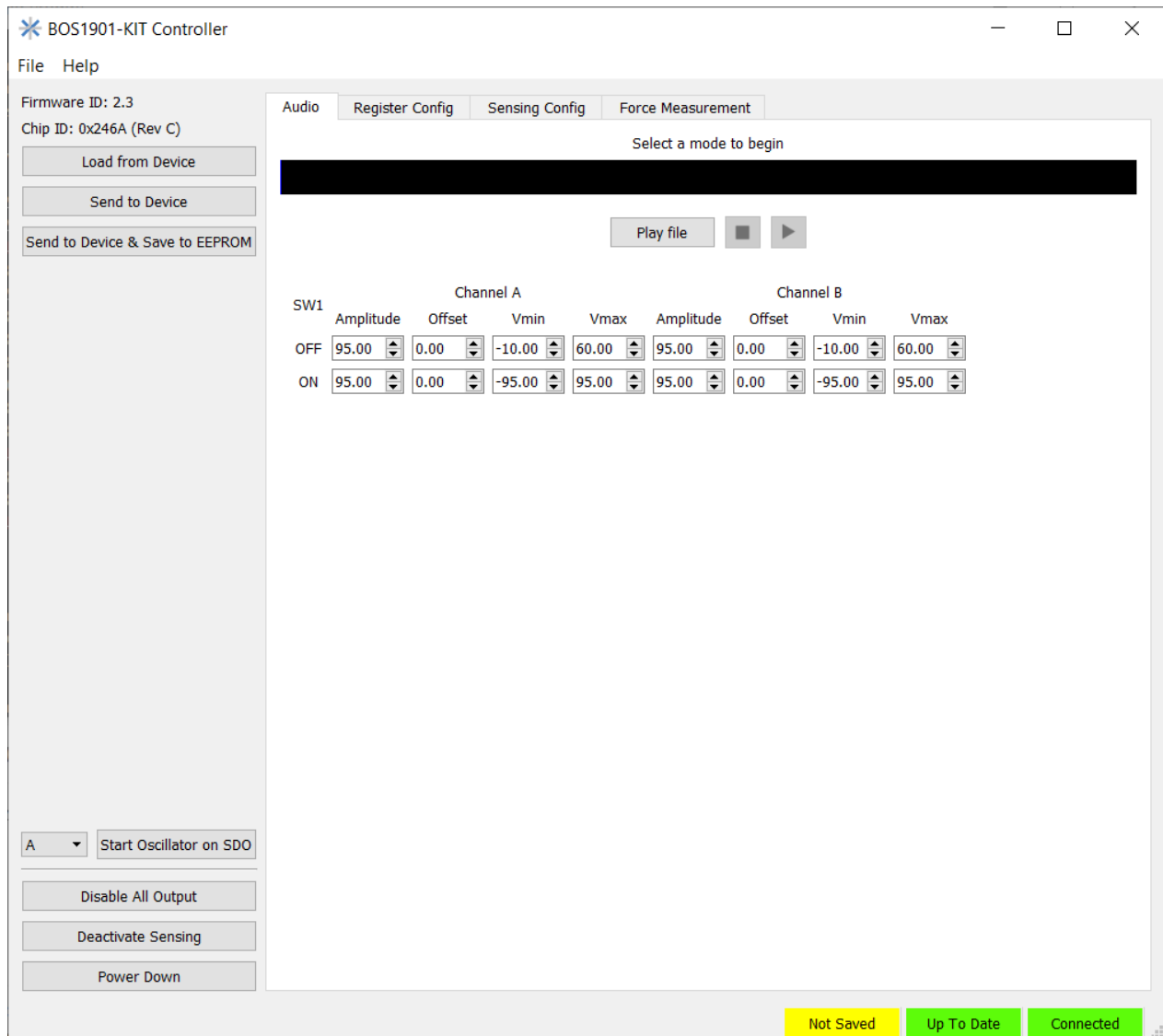

Figure 8: BOS1901-KIT Controller GUI – Main Window

8 Design Reference

8.1 Schematics

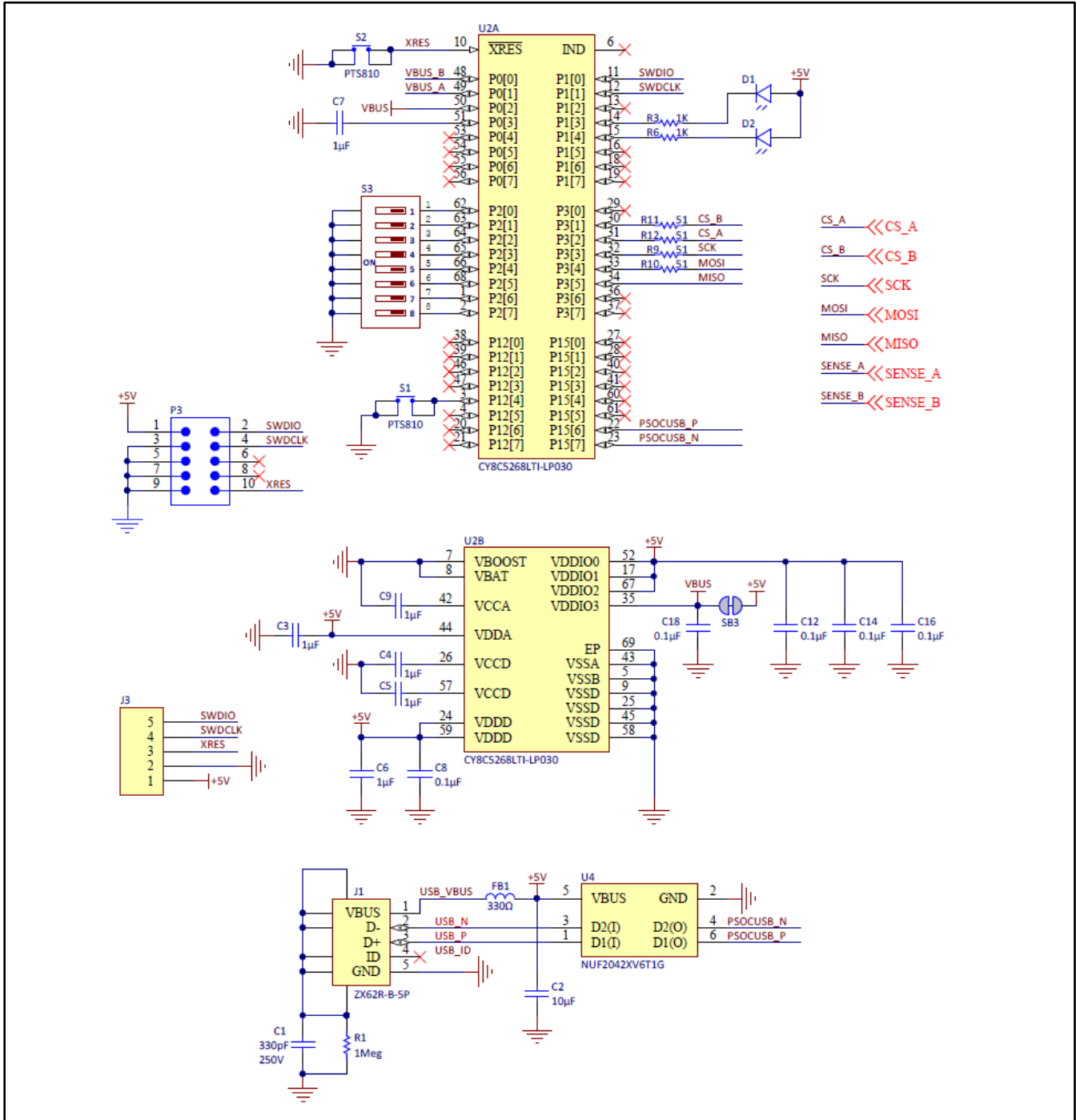

Figure 9: Schematic part 1 - USB and microcontroller

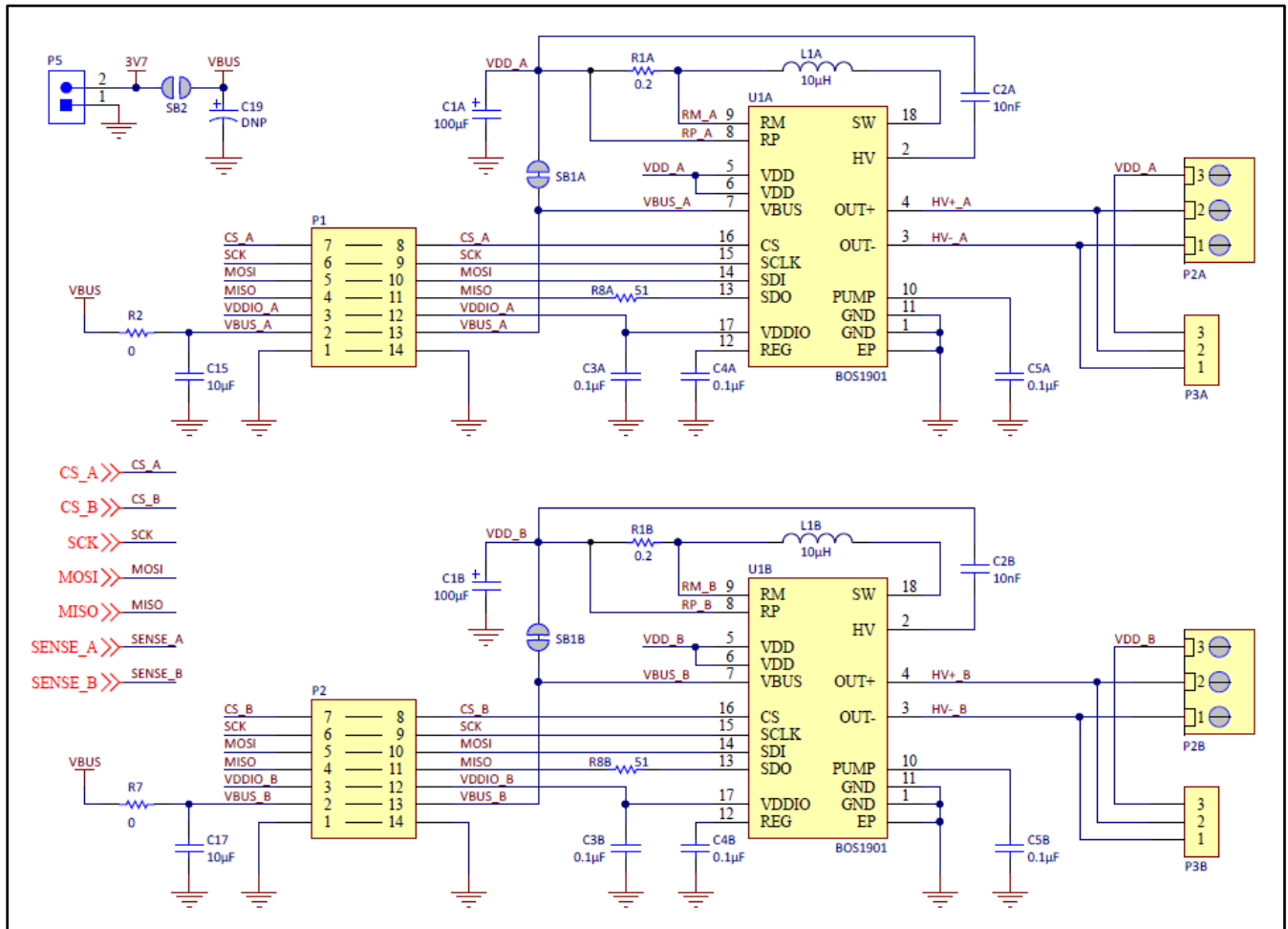

Figure 10: Schematic part 2 - BOS1901

8.2 PCB Layout

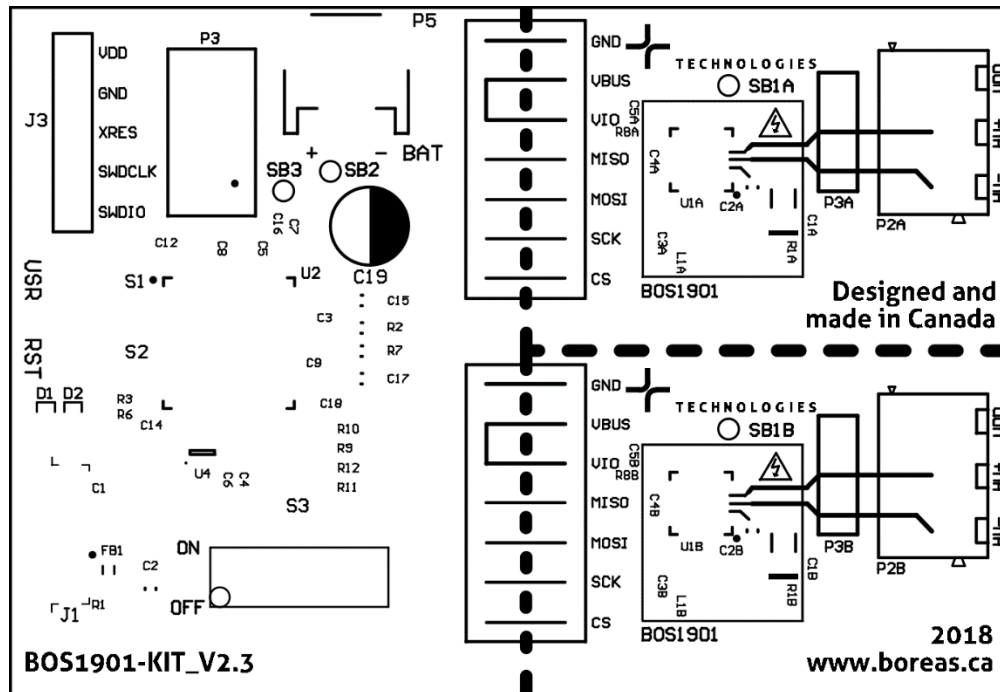

Figure 11: Layout view - Top Overlay (not to scale)

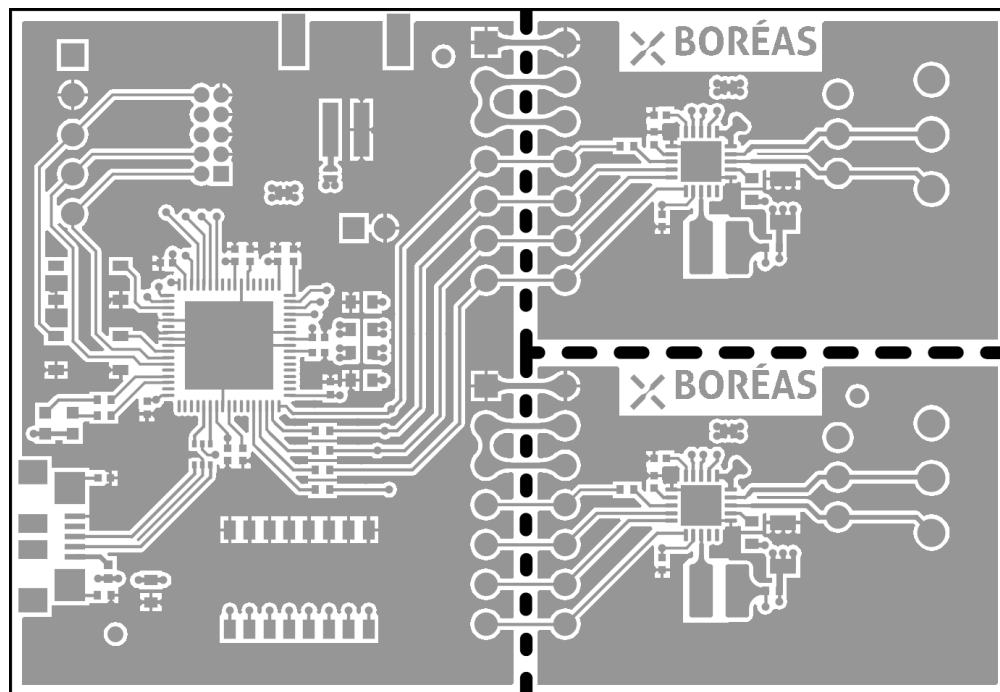

Figure 12: Layout view - Top Layer (not to scale)

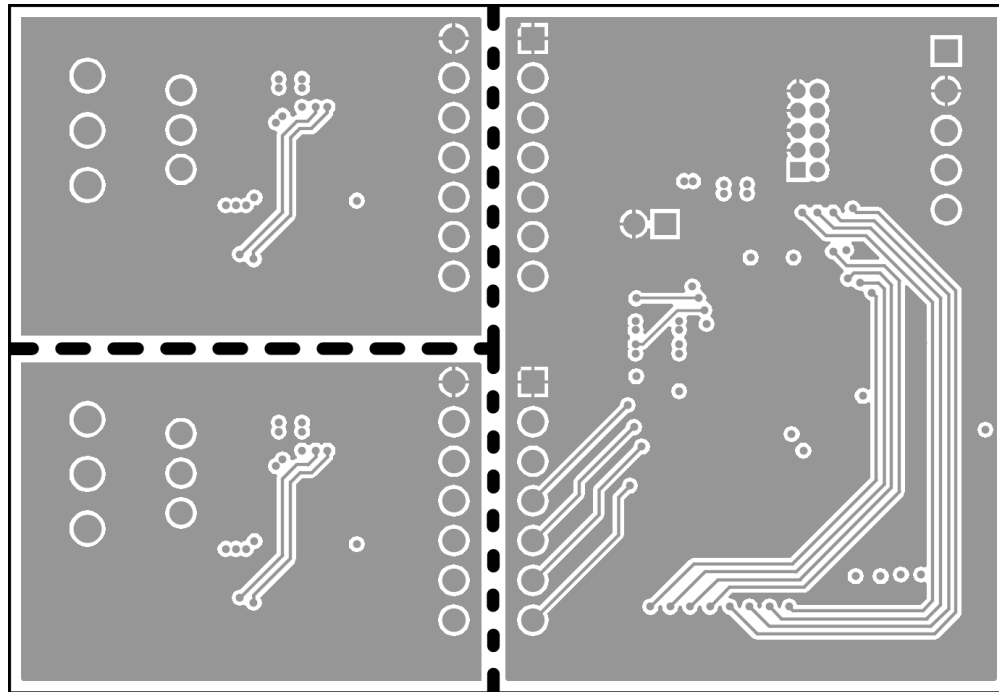

Figure 13: Layout view - Bottom Layer (mirrored, not to scale)

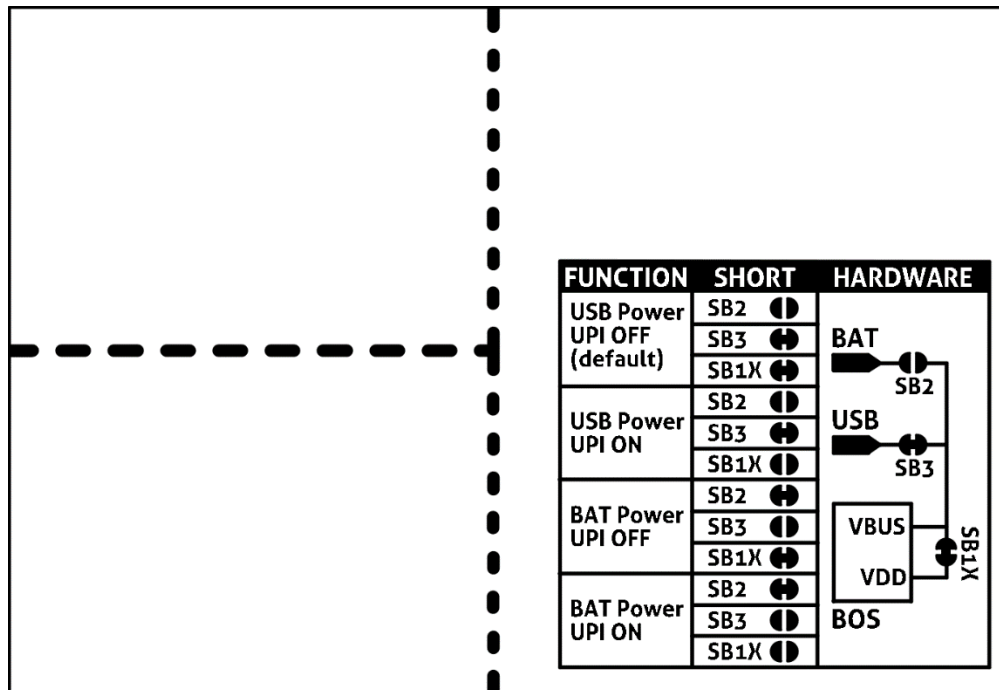

Figure 14: Layout view - Bottom Overlay (mirrored, not to scale)

8.3 Bill of Materials

The following is a list of the components that populate the evaluation PCB. Due to availability, some components with equivalent performance/characteristics may be installed on the actual evaluation PCB. If the exact part number is not available, the components can be replaced by ones with equivalent package and specifications.

Table 6: Bill of Materials

DESIGNATOR	QTY	VALUE	DESCRIPTION	MANUFACTURER	PART NUMBER
C1	1	330 pF	CAP CER 330PF 250V C0G/NP0 0402	KEMET	C0402C331JAGACAUTO
C1A, C1B	2	100 µF	CAP TANT POLY 100UF 6.3V 1206	Vishay / Polytech	T55A107M6R3C0045
C2, C15, C17	3	10 µF	CAP CER 10UF 10V X5R 0603	Taiyo Yuden	LMK107BJ106MALTD
C2A, C2B	2	10 nF	CAP CER 10000PF 200V X7R 0603	KEMET	C0603X103K2RECAUTO
C3, C4, C5, C6, C7, C9	6	1 µF	CAP CER 1UF 10V X6S 0402	TDK	CGB2A1X6S1A105M033BC
C3A, C3B, C4A, C4B, C5A, C5B, C8, C12, C14, C16, C18	11	0.1 µF	CAP CER 0.1UF 25V X5R 0402	Samsung Electro-Mechanics	CL05A104KA5NNNC
C19*	1	33 µF	CAP ALUM 33UF 20% 10V RADIAL	Nichicon	UMA1A330MDD
D1	1	-	LED YLW/GREEN DIFFUSED 1608 SMD	ROHM	SML-D12M1WT86
D2	1	-	LED RED DIFFUSED 1608 SMD	ROHM	SML-D12U1WT86
FB1	1	-	FERRITE BEAD 330 OHM 0402 1LN	Murata Electronics	BLM15PX331SN1D
J1	1	-	CONN RCPT USB MICRO B SMD R/A	Hirose Connector	ZX62R-B-5P(30)
J3	1	-	CONN HEADER .100" SNGL STR 5POS	Sullins	PRPC005SAAN-RC
L1A, L1B	2	10 µH	FIXED IND 10UH 1.2A 322 MOHM SMD	Würth Electronics	74438336100
P2A, P2B	2	-	TERMINAL BLOCK 3.5MM 3POS PCB	On Shore Technology Inc.	OSTTE030104
P3A, P3B	2	-	CONN HEADER FEMALE 3POS .1" GOLD	Sullins	PPPC031LFBN-RC
P3*	1	-	CONN HEADER 10POS DUAL .05" T/H	Samtec Inc.	FTSH-105-01-L-D-K
P5	1	-	CONN HEADER PH SIDE 2POS 2MM SMD	JST Sales America Inc.	S2B-PH-SM4-TB(LF)(SN)
R1	1	1 MΩ	RES SMD 1M OHM 1% 1/16W 0402	Yageo	RC0402FR-071ML
R1A, R1B	2	0.2 Ω	RES 0.2 OHM 1% 1/8W 0402	TE Connectivity	RLP73N1ER20FTDF
R2, R7	2	0 Ω	RES SMD 0 OHM JUMPER 1/10W 0603	Panasonic	ERJ-3GEY0R00V
R3, R6	2	1 kΩ	RES SMD 1K OHM 1% 1/16W 0402	Yageo	RT0402FRE071KL
R8A, R8B, R9, R10, R11, R12	6	51 Ω	RES SMD 51 OHM 1% 1/10W 0402	Panasonic Industrial Devices	ERJ-2RKF51R0X
S1, S2	2	-	SWITCH TACTILE SPST-NO 0.05A 16V	C&K	PTS810SJM250SMTRLFS
S3	1	-	SWITCH SLIDE 8 DIP SPST 25MA 24V	Grayhill Inc.	97C08SRT
U1A, U1B	2	-	Piezo Haptic Driver	Boréas Technologies	BOS1901-4
U2	1	-	IC MCU 32BIT 256KB FLASH 68QFN	Cypress Semiconductor	CY8C5268LTI-LP030
U4	1	-	FILTER RC(PI) 22 OHM/42PF SMD	ON Semiconductor	NUF2042XV6T1G

* These components are not populated on the PCB, the proposed part numbers are for reference only.

9 FAQ and Troubleshooting

Please refer to Boréas website for FAQ and Troubleshooting information, which will be maintained throughout the BOS1901-KIT lifecycle. It will also contain application note documents that will be helpful for the user writing his/her own code to operate the BOS1901.

10 Notice and Warning



Danger High Voltage!

Electric shock possible when connecting board to live wire. Board should be handled with care by a professional. For safety, use of isolated test equipment with overvoltage and/or overcurrent protection is highly recommended.



This product uses semiconductors that can be damaged by electrostatic discharge (ESD). When handling, care must be taken so that the devices are not damaged. Damage due to inappropriate handling is not covered by the warranty.

The following precautions must be taken:

- Do not open the protective conductive packaging until you have read the following and are at an approved anti-static work station.
- Use a conductive wrist strap attached to a good earth ground.
- If working on a prototyping board, use a soldering iron or station that is marked as ESD-safe.
- Always disconnect the microcontroller from the prototyping board when it is being worked on.
- Always discharge yourself by touching a grounded bare metal surface or approved anti-static mat before picking up an ESD - sensitive electronic component.
- Use an approved anti-static mat to cover your work surface.

11 Ordering Information

Table 7: Ordering information

	ORDERABLE DEVICE	PACKAGE	PACKING FORMAT	STANDARD QUANTITY	ACTUATORS	ROHS COMPLIANT	STATUS
1	BOS1901-KIT-A (Premium Set)	PCB 64x48mm (35x24)	Box (6x6x1)"	1/box 2 Channels 4 Actuators	TDK PowerHap™ 1204 Lateral TDK PowerHap™ 0904 Lateral TDK PowerHap™ 0909 Square Midé PPA-2014 Bending	Yes	Prod
2	BOS1901-KIT-B (Starter Set)	PCB 64x48mm (35x24)	Box (4x2x1)"	1/box 2 Channels 1 Actuator	TDK PowerHap™ 1204 Lateral	Yes	Prod

12 Document History

ISSUE	DATE	CHANGES
3	July 2019	Updated BOS1901-KIT ordering options.

BOREAS TECHNOLOGIES INC STANDARD TERMS FOR DEVELOPMENT KIT

PRIOR TO USING THE DEVELOPMENT KIT, USER MUST REVIEW THE USER DOCUMENTATION PROVIDED ON BOREAS.CA INCLUDING THE FULL VERSION OF BOREAS STANDARD TERMS AND CONDITIONS.

1) DELIVERY

1.1 BORÉAS TECHNOLOGIES (“BORÉAS”) delivers BORÉAS Development Kits including any accompanying demonstration software, components, and/or documentation which may be provided together or separately (collectively, a “DEV.KIT”) to the User (“User”) in accordance with the terms set forth herein. User’s acceptance of the DEV.KIT is expressly subject to the following terms.

1.2 DEV.KITs are intended solely for product or software developers for use in a research and development setting to facilitate feasibility evaluation, experimentation, or scientific analysis of BORÉAS semiconductors products. DEV.KITs have no direct function and are not finished products. DEV.KITs shall not be directly or indirectly assembled as a part or subassembly in any finished product. For clarification, any software or software tools provided with the DEV.KIT (“Software”) shall not be subject to the terms and conditions set forth herein but rather shall be subject to the applicable terms that accompany such Software

1.3 DEV.KITs are not intended for consumer or household use. DEV.KITs may not be sold, sublicensed, leased, rented, loaned, assigned, or otherwise distributed for commercial purposes by Users, in whole or in part, or used in any finished product or production system.

2) LIMITED WARRANTY AND RELATED REMEDIES/DISCLAIMERS:

2.1 These terms do not apply to Software. The warranty, if any, for Software is covered in the applicable Software License Agreement.

2.2 BORÉAS warrants that the BORÉAS DEV.KIT will conform to BORÉAS’s published specifications for ninety (90) days after the date BORÉAS delivers such DEV.KIT to User. Notwithstanding the foregoing, BORÉAS shall not be liable for a nonconforming DEV.KIT if (a) the nonconformity was caused by neglect, misuse or mistreatment by an entity other than BORÉAS, including improper installation or testing, or for any DEV.KITs that have been altered or modified in any way by an entity other than BORÉAS, (b) the nonconformity resulted from User’s design, specifications or instructions for such DEV.KITs or improper system design, or (c) User has not paid on time. Testing and other quality control techniques are used to the extent BORÉAS deems necessary. BORÉAS does not test all parameters of each DEV.KIT.

2.3 BORÉAS’s sole liability shall be at its option to repair or replace DEV.KITs that fail to conform to the warranty set forth above, or credit User’s account for such DEV.KIT. BORÉAS’s liability under this warranty shall be limited to DEV.KITs that are returned during the warranty period to the address designated by BORÉAS and that are determined by BORÉAS not to conform to such warranty. If BORÉAS elects to repair or replace such DEV.KIT, BORÉAS shall have a reasonable time to repair such DEV.KIT or provide replacements. Repaired DEV.KITs shall be warranted for the remainder of the original warranty period. Replaced DEV.KITs shall be warranted for a new full ninety (90) day warranty period.

3) DEV.KIT USE RESTRICTIONS AND WARNINGS:

4.1 DEV.KITs ARE NOT FOR USE IN FUNCTIONAL SAFETY AND/OR SAFETY CRITICAL EVALUATIONS, INCLUDING BUT NOT LIMITED TO EVALUATIONS OF LIFE SUPPORT APPLICATIONS.

4.2 User must read and apply the user guide and other available documentation provided by BORÉAS regarding the DEV.KIT prior to handling or using the DEV.KIT, including without limitation any warning or restriction notices. The notices contain important safety information related to, for example, temperatures and voltages.

4.3 Safety-Related Warnings and Restrictions:

4.3.1 User shall operate the DEV.KIT within BORÉAS’s recommended specifications and environmental considerations stated in the user guide, other available documentation provided by BORÉAS, and any other applicable requirements and employ reasonable and customary safeguards. Exceeding the specified performance ratings and specifications (including but not limited to input and output voltage, current, power, and environmental ranges) for the DEV.KIT may cause personal injury or death, or property damage. If there are questions concerning performance ratings and specifications, User should contact a BORÉAS field representative prior to connecting interface electronics including input power and intended loads. Any loads applied outside of the specified output range may also result in unintended and/or inaccurate operation and/or possible permanent damage to the DEV.KIT and/or interface electronics. Please consult the DEV.KIT user guide prior to connecting any load to the DEV.KIT output. If there is uncertainty as to the load specification, please contact a BORÉAS field representative.

During normal operation, even with the inputs and outputs kept within the specified allowable ranges, some circuit components may have elevated case temperatures. These components include but are not limited to linear regulators, switching transistors, pass transistors, current sense resistors, and heat sinks, which can be identified using the information in the associated documentation. When working with the DEV.KIT, please be aware that the DEV.KIT may become very warm.

4.3.2 DEV.KITs are intended solely for use by technically qualified, professional electronics experts who are familiar with the dangers and application risks associated with handling electrical mechanical components, systems, and subsystems. User assumes all responsibility and liability for proper and safe handling and use of the DEV.KIT by User or its employees, affiliates, contractors or designees. User assumes all responsibility and liability to ensure that any interfaces (electronic and/or mechanical) between the DEV.KIT and any human body are designed with suitable isolation and means to safely limit accessible leakage currents to minimize the risk of electrical shock hazard. User assumes all responsibility and liability for any improper or unsafe handling or use of the DEV.KIT by User or its employees, affiliates, contractors or designees.

4.4 User assumes all responsibility and liability to determine whether the DEV.KIT is subject to any applicable international, federal, state, or local laws and regulations related to User's handling and use of the DEV.KIT and, if applicable, User assumes all responsibility and liability for compliance in all respects with such laws and regulations. User assumes all responsibility and liability for proper disposal and recycling of the DEV.KIT consistent with all applicable international, federal, state, and local requirements.

4) ACCURACY OF INFORMATION:

To the extent BORÉAS provides information on the availability and function of DEV.KITs, BORÉAS attempts to be as accurate as possible. However, BORÉAS does not warrant the accuracy of DEV.KIT descriptions, DEV.KIT availability or other information on its websites as accurate, complete, reliable, current, or error-free.

5) DISCLAIMERS:

6.1 EXCEPT AS SET FORTH ABOVE, DEV.KITs AND ANY MATERIALS PROVIDED WITH THE DEV.KIT (INCLUDING, BUT NOT LIMITED TO, REFERENCE DESIGNS AND THE DESIGN OF THE DEV.KIT ITSELF) ARE PROVIDED "AS IS" AND "WITH ALL FAULTS." BORÉAS DISCLAIMS ALL OTHER WARRANTIES, EXPRESS OR IMPLIED, REGARDING SUCH ITEMS, INCLUDING BUT NOT LIMITED TO ANY EPIDEMIC FAILURE WARRANTY OR IMPLIED WARRANTIES OF MERCHANTABILITY OR FITNESS FOR A PARTICULAR PURPOSE OR NON-INFRINGEMENT OF ANY THIRD-PARTY PATENTS, COPYRIGHTS, TRADE SECRETS OR OTHER INTELLECTUAL PROPERTY RIGHTS.

6.2 EXCEPT FOR THE LIMITED RIGHT TO USE THE DEV.KIT SET FORTH HEREIN, NOTHING IN THESE TERMS SHALL BE CONSTRUED AS GRANTING OR CONFERRING ANY RIGHTS BY LICENSE, PATENT, OR ANY OTHER INDUSTRIAL OR INTELLECTUAL PROPERTY RIGHT OF BORÉAS, ITS SUPPLIERS/LICENSORS OR ANY OTHER THIRD PARTY, TO USE THE DEV.KIT IN ANY FINISHED END-USER OR READY-TO-USE FINAL PRODUCT, OR FOR ANY INVENTION, DISCOVERY OR IMPROVEMENT, REGARDLESS OF WHEN MADE, CONCEIVED OR ACQUIRED.

6) USER'S INDEMNITY OBLIGATIONS AND REPRESENTATIONS.

USER WILL DEFEND, INDEMNIFY AND HOLD BORÉAS, ITS LICENSORS AND THEIR REPRESENTATIVES HARMLESS FROM AND AGAINST ANY AND ALL CLAIMS, DAMAGES, LOSSES, EXPENSES, COSTS AND LIABILITIES (COLLECTIVELY, "CLAIMS") ARISING OUT OF OR IN CONNECTION WITH ANY HANDLING OR USE OF THE DEV.KIT THAT IS NOT IN ACCORDANCE WITH THESE TERMS. THIS OBLIGATION SHALL APPLY WHETHER CLAIMS ARISE UNDER STATUTE, REGULATION, OR THE LAW OF TORT, CONTRACT OR ANY OTHER LEGAL THEORY, AND EVEN IF THE DEV.KIT FAILS TO PERFORM AS DESCRIBED OR EXPECTED.

7) SPECIFIC LIMITATIONS ON DAMAGES AND LIABILITY:

IN NO EVENT SHALL BORÉAS'S AGGREGATE LIABILITY FROM ANY USE OF AN DEV.KIT PROVIDED HEREUNDER, INCLUDING FROM ANY WARRANTY, INDEMNITY OR OTHER OBLIGATION ARISING OUT OF OR IN CONNECTION WITH THESE TERMS, EXCEED THE TOTAL AMOUNT PAID TO BORÉAS BY USER FOR THE PARTICULAR DEV.KIT(S) AT ISSUE DURING THE PRIOR TWELVE (12) MONTHS WITH RESPECT TO WHICH LOSSES OR DAMAGES ARE CLAIMED. THE EXISTENCE OF MORE THAN ONE CLAIM SHALL NOT ENLARGE OR EXTEND THIS LIMIT.

8) RETURN POLICY:

Except as otherwise provided, BORÉAS does not offer any refunds, returns, or exchanges. Furthermore, no return of DEV.KIT(s) will be accepted if the package has been opened and no return of the DEV.KIT(s) will be accepted if they are damaged or otherwise not in a resalable condition. If User feels it has been incorrectly charged for the DEV.KIT(s) it ordered or that delivery violates the applicable order, User should contact BORÉAS. All refunds will be made in full within thirty (30) working days from the return of the components(s), excluding any postage or packaging costs.

9) GOVERNING LAW:

These terms and conditions shall be governed by and interpreted in accordance with laws of the Province of Quebec and federal laws of Canada applicable, without reference to conflict-of-laws principles. User agrees that non-exclusive jurisdiction for any dispute arising out of or relating to these terms and conditions lies within Quebec Courts, sitting in the judicial district of Bedford.

Notwithstanding the foregoing, any judgment may be enforced in any Canada or foreign court, and BORÉAS may seek injunctive relief in any Canada or foreign court.

**BOREAS TECHNOLOGIES INC
WARNING
EXPORT NOTICE**

Recipient agrees to not knowingly export or re-export, directly or indirectly, any product or technical data (as defined by the Canada, U.S., EU, and other Export Administration Regulations) including software, or any controlled product restricted by other applicable national regulations, received from BORÉAS TECHNOLOGIES under this Agreement, or any direct product of such technology, to any destination to which such export or re-export is restricted or prohibited by Canada, U.S., E.U. or other applicable laws, without obtaining prior authorization from competent Government authorities to the extent required by those laws.

This provision shall survive termination or expiration of this Agreement.

According to our best knowledge of the state and end use of our product or technology, and in compliance with the export control regulations of dual-use goods in force in the origin and exporting countries, this technology is classified as follows:

US ECCN: 3E991

EU ECCN: EAR99

And may require export or re-export license for shipping in compliance with the applicable regulations of certain countries.