



Waves Spectrometer Software

Spectrometer User Manual

User Guide

Broadcom, the pulse logo, Connecting everything, Avago Technologies, Avago, and the A logo are among the trademarks of Broadcom and/or its affiliates in the United States, certain other countries, and/or the EU.

Copyright © 2018 by Broadcom. All Rights Reserved.

The term “Broadcom” refers to Broadcom Inc. and/or its subsidiaries. For more information, please visit www.broadcom.com.

Broadcom reserves the right to make changes without further notice to any products or data herein to improve reliability, function, or design. Information furnished by Broadcom is believed to be accurate and reliable. However, Broadcom does not assume any liability arising out of the application or use of this information, nor the application or use of any product or circuit described herein, neither does it convey any license under its patent rights nor the rights of others.

Table of Contents

Chapter 1: Introduction	6
1.1 Product Overview	6
1.2 Hardware Features.....	7
1.3 Software Features.....	7
1.4 Applications	7
1.5 System Requirements	8
1.6 Package Contents.....	8
1.7 Optional Accessories	8
Chapter 2: Installation	9
2.1 USB Interface	9
2.2 UART Interface.....	10
2.3 SPI Interface	11
2.4 Sensor Cooling (Qred Only)	11
2.4.1 Sensor Temperature and Dark Signal.....	11
2.4.2 Special Notes for Extended InGaAs Sensors	13
2.4.3 Power Supply.....	13
2.4.4 Sensor Gain.....	14
2.5 Optical Setup.....	14
2.6 Troubleshooting.....	15
2.6.1 Green and Red LEDs Are Continuously Lit	15
2.6.2 Green Light on the Spectrometer Is Off, Red Light Is Flashing or Continuously Lit, and the Device Does Not React	15
2.6.3 Waves Cannot Find the Device	15
Chapter 3: Operation	16
3.1 Introduction	16
3.2 Overview	16
3.3 Taking Spectra.....	17
3.4 Spectrum Display.....	18
3.5 Working with Spectra	19
3.6 File Operations.....	20
3.6.1 Save.....	20
3.6.2 Print.....	20
3.6.3 Export.....	21
3.7 Spectrum Calculations.....	21
3.7.1 Adjust Offset	21

- 3.7.2 Normalize..... 21
- 3.7.3 Differentiate 21
- 3.7.4 Apply Smoothing..... 22
- 3.7.5 Correct Baseline 22
- 3.7.6 Duplicate..... 22
- 3.7.7 Arithmetic Operations 22
- 3.7.8 Add Average Over All/Visible Spectra 22
- 3.7.9 Create New Wavelength Scale..... 23
- 3.8 Tools..... 23**
 - 3.8.1 Strip Chart..... 23
 - 3.8.2 Loupe..... 23
 - 3.8.3 Colorimetric Analysis 23
 - 3.8.4 Add Reference Spectra 24
 - 3.8.5 Peak Width Diagram..... 24
- 3.9 Absorption, Reflection, and Transmission Measurements 24**
 - 3.9.1 Principle 24
 - 3.9.2 Measurement..... 25
- 3.10 Calibration 25**
 - 3.10.1 Calibration Accuracy 26
 - 3.10.2 Wavelengths 26
 - 3.10.3 Dark Spectrum..... 27
 - 3.10.4 Spectral Sensitivity 28
 - 3.10.5 Nonlinearity..... 28
- 3.11 Triggering and I/O Port..... 29**
 - 3.11.1 Trigger Options 29
 - 3.11.2 I/O Channels..... 30

Chapter 4: Software Development Kit 31

Chapter 5: Technical Support 32

- 5.1 Getting Help..... 32
- 5.2 Software Updates..... 32

Chapter 6: Specifications 33

- 6.1 Qwave 33
- 6.2 Qmini..... 35
- 6.3 Qred..... 37
- 6.4 Pin Assignment 39
 - 6.4.1 9-Pin Auxiliary Interface 39
 - 6.4.1.1 Qwave 1 Pins..... 40
 - 6.4.1.2 Qwave 2 Pins..... 40

6.4.2 30-Pin Auxiliary Interface..... 41

Chapter 7: Certifications and Compliance 44

Revision History 47

AFBR-Spectro-UG100; October 2, 2018 47

Chapter 1: Introduction

This manual describes how to use the Qwave, Qmini, and Qred spectrometers with Waves application software. For information about how to control a spectrometer from custom user software, refer to the manuals included in the Software Development Kit (SDK).

Product Overview

With its focal length of 75 mm, the Qwave spectrometer offers technical specifications normally found in much larger spectrometers. It is controlled and operated by the spectroscopy software *Waves*, which not only includes unique sophisticated algorithms for data acquisition and evaluation, but also provides these features through a clear and straightforward interface. This makes the Qwave the ideal spectroscopic instrument for all scientific applications that require a resolution of 0.2 to 0.5 nm and a numerical aperture of up to 0.10.

Within an amazingly small design, the Qmini delivers technical specifications that are unprecedented at this size. Its compact design enables tight integration in applications where space is limited, like hand-held analysis devices. This manual describes the 2016 version of the Qmini (with the 30-pin auxiliary connector). For the previous version, download the corresponding manual from our website.

The Qred is the world's first truly portable high-performance near-infrared (NIR) spectrometer. On a footprint smaller than a credit card, it includes high-throughput Czerny-Turner optics with a cooled or uncooled InGaAs image sensor. The Qred spectrometer breaks the size and cost barriers that prevented widespread applications of NIR spectroscopy in many fields including food safety, quality control, medical diagnostics, and pharmaceutical analysis. The advanced thermal design provides high thermal stability and excellent heat transfer without a fan. The rugged design has no moving parts, ensuring reliable operation in rough environments.

Hardware Features

- Miniature design
- High spectral resolutions
- High sensitivity and dynamic range
- Exceptional thermal stability
- Optical input via SMA fiber connector or free focused beam
- Four I/O channels for external triggering, shutter control, and general purpose I/O (GPIO)
- Controlled and powered via USB 2.0

The new version of the electronics board enables:

- Full processing of spectra in the device
- Averaging and smoothing
- Binning and buffering of spectra
- A choice of different communication interfaces

Software Features

- Take and display series of spectra
- Automatic exposure control with dark spectrum interpolation
- Import most ASCII-based file formats
- Export as ASCII table to almost any numerical analysis software
- Comprehensive tools for displaying and analyzing spectra
- Strip charts for comparing characteristic values between multiple spectra including peak follower in real time
- Graph printing and export to PDF
- Dynamic peak finder (no need to set a threshold level)
- Transmission, reflection, absorption, and colorimetric measurements

Applications

- Light analysis
- Chemical research

- Raman spectroscopy
- Color measurement
- Quality control
- Counterfeit detection
- Environmental analysis
- Forensic analysis
- System integration
- Process control and monitoring

System Requirements

- Windows 10, 8, 7, Vista, or XP (32 or 64-bit)
- .NET Framework Version 3.5 or 4.0 (already included in most versions of Windows)

Package Contents

The bulk spectrometer includes the device along with the calibration and test report. Qred also ships with an AC power adapter.

The optional Spectrometer Accessory Kit includes the following:

- USB data cable
- CD-ROM with Waves spectroscopy software including device driver, software development kit, and a PDF copy of this manual
- Printed user manual

Optional Accessories

- I/O port adapter
- Fiber optical cable
- Cosine correcting probe for irradiance measurements
- SMA collimator

Additional specialized accessories are available upon request.

Chapter 2: Installation

USB Interface

Installing the spectrometer is a very straightforward process. Simply install the software and then connect the device to a USB port. For the operating system to properly recognize the device, install the software first before attaching the device. Double-click on the WavesSetup.exe file from the CD-ROM. Alternatively, download the latest software version from our website. The setup package installs the application software and the device driver.

The software is tested with 32-bit and 64-bit versions of Windows 10, 8, 7, Vista, and XP. It requires the Microsoft .NET framework version 3.5 or 4.0, which is already installed on most PCs. If this framework is not installed, the setup package prompts to install it first. Find the setup file for the .NET framework on the CD or download it from the Microsoft website.

Install the software on as many systems as necessary. For example, install it in the lab for measurements and in the office for further spectrum analysis.

After the software is installed, connect the spectrometer to a USB port on the computer. The USB port must supply an electrical current of up to 200 mA, so connect the spectrometer directly to your system or to an externally powered USB hub. A flashing red LED on the device indicates that the port is not supplying enough power.

Upon starting, the Waves software automatically searches for spectrometers and, if it finds one, initializes the device. It may take a few seconds before the spectrometer is properly recognized by the operating system.

If Waves cannot find a spectrometer (or finds several), a dialog window displays with options for choosing a specific device or the simulated spectrometer setting. The simulated spectrometer option is used to evaluate the software without connecting to an actual device. Access this dialog window at any time by selecting Device Setup from the File menu.

UART Interface

The Qmini and Qred spectrometers can also be controlled with the UART interface available on the front-side auxiliary connector. This interface is similar to a regular RS-232 interface, but the voltage levels on the data lines are 0V (low) and +3.3V (high) instead of the RS-232-specified positive and negative voltages. To connect the device to a regular RS-232 serial port, use the optional RS-232 converter cable. See [Specifications on page 36](#) for a pinout of the auxiliary connector.

Though most users of the UART interface connect the device to custom user hardware, first operate the spectrometer using a PC and the Waves application software to become familiar with the device.

When the Qwave is powered on, it initially listens on all interfaces. As soon as a message is received on an interface, this interface is selected and all other interfaces are disabled. For example, if communicating with the device via USB, it will not listen on the UART interface. To prevent any confusion, only connect the interface planned for use.

The default data rate for the UART interface is 57,600 baud. This is actually quite slow, so we recommend to increase it in the Device Configuration window. The maximum data may be limited by the serial port of your computer. When connecting to a device via UART, the Waves application software tries the data rate of the device that was most recently connected. This may cause a data rate mismatch if, for example, it is changed and then connected to a different PC. This problem can easily be resolved by connecting the device via USB. When the device connection is then opened in Waves, the software reads the data rate from the device and uses it for subsequent UART communication.

To use the spectrometer and UART interface with a PC, use the RS-232 converter cable and connect it to a serial port on the PC. Because a regular serial port does not provide a supply voltage, an external 5V DC power supply is required to power the spectrometer. Connect the power supply to the wires marked red (+ 5V) and blue (ground).

Upon connecting the device to power, both LEDs are initially off. When the device receives a command on an interface or if it enumerates on the USB bus, the red LED turns off. If the green LED is off, check the power supply.

To install the Waves application software, proceed as described in the previous chapter. When using Waves with the UART interface, note that there are two differences to the USB version:

- Data transfer is slower. The default speed is 57,600 baud, but can be increased from the Device Configuration window. The maximum speed may be limited by the serial port on your system.
- To open the device connection, de-select the **Auto-Scan all ports** option and select **Qseries spectrometer** on the correct COM port.

To connect the Qwave via the UART interface to custom user hardware, see the connector pinout in [Specifications on page 36](#).

SPI Interface

The Qmini and Qred devices can also be controlled via the serial peripheral interface (SPI). Refer to the NioLink Protocol Manual in the Software Development Kit (SDK) for details.

Sensor Cooling (Qred Only)

Sensor Temperature and Dark Signal

The Qred uses a specialized Indium Gallium Arsenide (InGaAs) image sensor to measure light in the Near-Infrared (NIR) wavelength range. These sensors have a much larger dark signal than regular sensors for visible light. To obtain a precise measurement, the image sensor should be cooled to minimize the dark signal. Therefore, most Qred spectrometers are equipped with a Thermo-electric cooler (TEC) to keep the image sensor at temperatures below 0°C.

There are two types of sensors:

- **Regular InGaAs sensors** cover wavelength ranges up to 1700 nm. If possible, keep these sensors cooled to temperatures below 0°C. The default operating temperature for a Qred with this kind of sensor is -5°C. The temperature may be decreased further if adequate cooling can be provided. This further reduces the dark signal. Operating these sensors at room temperature causes a decrease in measurement precision.
- **Extended InGaAs sensors** cover wavelength ranges beyond 1700 nm and up to 2500 nm. These sensors have a much larger dark signal and therefore must be cooled to lower temperatures than regular InGaAs sensors. These sensors include a two-stage thermo-electric cooler and should be operated at the default temperature of -20°C or below, depending on the available cooling. In addition, exposure time must be kept short to prevent the sensor from getting saturated by the dark signal. To measure weak signals, consider increasing the Averaging value instead.

The Qred software uses sophisticated algorithms to automatically compensate the dark signal for different exposure times and temperatures. However, due to the large magnitude of the dark signal, it may not be corrected completely, especially for extended InGaAs sensors. If measurements must be as precise as possible, take a background spectrum first and use it for subsequent measurements (see [Absorption, Reflection, and Transmission Measurements on page 27](#)).

The Qred controls the temperature automatically, but be aware that it may take a few seconds to reach the target temperature and there are certain requirements concerning heat dissipation and power supply.

In the Waves software, open the Temperature Control window from the Device menu. There are options for setting a target temperature and turning the temperature control on/off. Check the actual temperature in the status bar at the bottom of the main window. Wait until the target temperature is reached before starting measurements. The blue LED on the device also indicates the status of the temperature control:

- Blue LED is off: The temperature control is turned off.
- Blue LED is blinking: The target temperature has not yet been reached.
- Blue LED is continuously lit: The target temperature has been reached.

Change the operating temperature depending on your requirements and setup. When setting the temperature, take the following points into account:

- The dark noise decreases significantly upon lowering the temperature.
- The minimum temperature that can be reached depends on the power supply (see [Power Supply on page 13](#)) and the case temperature. The case temperature corresponds to the sink temperature displayed in the Temperature Control window. The TEC inside the Qred can achieve a maximum temperature difference of about 35K for regular sensors. So if the ambient temperature is 25°C, the minimum temperature is about -10°C. Extended InGaAs sensors feature a two-stage TEC than can achieve temperature differences of about 55K.
- For short measurements, heat dissipation is not a concern. However, when taking spectra for more than a few minutes ensure that the case does not get too hot. An increase in case temperature limits the cooling that can be achieved. To increase heat dissipation, the first step may be to place the device on a metal plate (like an optics table). If further cooling is required, attach a dedicated heat sink to the bottom of the device with thermal grease or a thermally conductive pad. Continuous operation over longer time periods of the spectrometer usually requires an additional external fan.
- If the heat generated inside the image sensor cannot be dissipated quickly enough, a heat build-up may occur. In this case, the accumulated heat causes the device case to heat up, which in turn increases the electrical power required to cool the sensor, which in turn causes the case to heat up even more. This condition is also known as thermal runaway. If this occurs, turn off the temperature control for a while to let the device cool down. Consider improving the heat dissipation away from the device.
- To protect against thermal runaway, set a maximum sink temperature in the Temperature Control window. For additional protection against overheating there is also a hard-coded limit of 70°C, above which the temperature control circuit shuts down.

Special Notes for Extended InGaAs Sensors

To ensure accurate measurements with these sensors, adhere to the following points:

- Before taking any spectra, ensure that the target temperature is reached. Verify the target temperature in the status bar at the bottom of the main window.
- To take spectra for more than a few minutes, provide adequate cooling to the Qred housing. See [UART Interface on page 9](#) for details. Monitor the case temperature in the Temperature Control window.
- The software automatically compensates the dark signal as much as possible. However, due to the large magnitude of the dark signal, it may not be completely corrected. For precise measurements, set a fixed exposure time and take a background spectrum (see [Absorption, Reflection, and Transmission Measurements on page 27](#) for details).
- When using an Extended InGaAs sensor with 512 pixels, a comb-like zig-zag pattern may display in the spectrum. This is because odd and even pixels are processed differently inside the sensor. This pattern depends on how light is coupled into the spectrometer. If using an optical fiber, this pattern is usually invisible or very low. Recalibrate the spectral sensitivity with a calibrated tungsten lamp to further reduce this zig-zag pattern (see [Calibration on page 29](#)).

Power Supply

The Qred can be powered by USB only. However, in this case the power available for cooling the sensor is limited and may only be able to cooled to 5K to 10K below the ambient temperature. To cool the sensor below 0°C for precise measurements, an additional external power supply may be required.

For initial measurements, connect the supplied AC power adapter to the device. This ensures that the sensor cooling is not limited by the power supply. Later, examine other power supply options if needed.

When connecting the Qred to a regular USB port that can supply 500 mA, only 280 mA is available for cooling. If connected to a USB 3.0 port, this current may increase. Connect an external 12V power supply to the front-side AUX connector to achieve a maximum cooling current of 1.8A.

Sensor Gain

The InGaAs image sensor used inside the Qred has two operation modes:

- Low Gain mode provides a large dynamic range and better linearity.
- High Gain mode is better suited for weak signals.

Change the gain setting in the Device Configuration windows. When changing the gain setting, take a new set of dark spectra (see [Calibration on page 29](#)).

For Qreds with an extended InGaAs sensor (beyond 1700 nm), High Gain mode is not recommended because the dark signal gets even larger and the nonlinearity cannot be reasonably corrected.

Optical Setup

The light enters the Qred spectrometer through a 20 μm slit (other slits are also available). This slit is observable by looking into the fiber optical connector on the front side of the device.

If the measured light is quite strong, simply point the spectrometer towards it. For example, test the spectrometer by pointing it towards your computer screen or desk light. In most cases, however, a special optical probe is required to collect as much light as possible. To guide the light from the probe to the spectrometer, most users prefer a simple fiber optical cable with SMA connectors. Alternatively, light can be focused directly onto the entrance slit without fibers using your own optics. Use standard fiber optical cables with a core diameter of 400 μm .

The calibration for the spectral sensitivity correction and the optical power was made with a 400 μm fiber optical cable. If a different fiber is used, or especially if the spectrometer is pointed towards the light source, the measured spectrum might not be accurate. When using a calibrated light source, the spectral sensitivity can be recalibrated for any optical setup (see [Calibration on page 29](#)).

Focus the light directly onto the entrance slit for the best sensitivity and lowest stray light. Ensure the following:

- The focused light is aligned on the center of the entrance slit.
- The height of the light spot on the entrance slit is 400 μm or smaller.
- The numerical aperture of the focusing optics is close to 0.14, matching the numerical aperture of the spectrometer.

The spectrometer does not detect light from outside a cone that corresponds to the specified numerical aperture. Therefore, if the focusing optics has a larger aperture, some light intensity is lost inside the spectrometer.

Troubleshooting

Green and Red LEDs Are Continuously Lit

This usually indicates that the device driver is not installed.

Green Light on the Spectrometer Is Off, Red Light Is Flashing or Continuously Lit, and the Device Does Not React

This indicates that the device has turned itself off because the USB port was not able to supply enough power. This also may happen if the USB cable is too long or damaged. Disconnect the device and try a different USB port or cable.

Waves Cannot Find the Device

Disconnect and reconnect the spectrometer, close the Device Config window, wait a few seconds, and open this window again from the File menu. If this does not resolve the issue, restart the PC and try again.

Check the website for software updates.

If the software still cannot find the device, check the Device Manager from the Windows Control Panel. The spectrometer should display as Qred in the Measurement and Control category. If the spectrometer is marked with an exclamation or question mark, remove the device, uninstall the software from the Windows Control Panel, restart the PC, and install the software again.

If the spectrometer is not listed at all in the Device Manager, try a different USB port. If the device does not work on one PC, but works on others, the USB port may not provide enough power for the spectrometer. In this case, use an externally powered USB hub.

For further assistance, contact Technical Support (see [Getting Help on page 35](#)).

Chapter 3: Operation

Introduction

The Waves spectroscopy software is designed to provide a clean and straightforward user interface that does not impede or compromise advanced features and precision. For users new to spectroscopy, it is easy to start using the software and taking spectra without having to worry about details like calibration or dark spectra. For users with previous spectroscopy software experience, the following differences are noticeable in Waves:

- One mode of operation includes all relevant types of measurements (absorption, irradiance, scope, and so on) through a consistent and clear interface.
- Waves favors a simple self-explanatory terminology instead of complicated terms. For example, the software uses the term Exposure time instead of Integration time, because the average user does not know what is being integrated.
- There are no wizards to help with complicated tasks, because wizards tend to conceal the actual task. These tasks are accessible through a clear and unified interface, for better understanding.

Overview

Upon launch, the software searches for an attached Qred spectrometer. If one is found, the software automatically initializes it. The software then presents the main window. The main window consists of several panels:

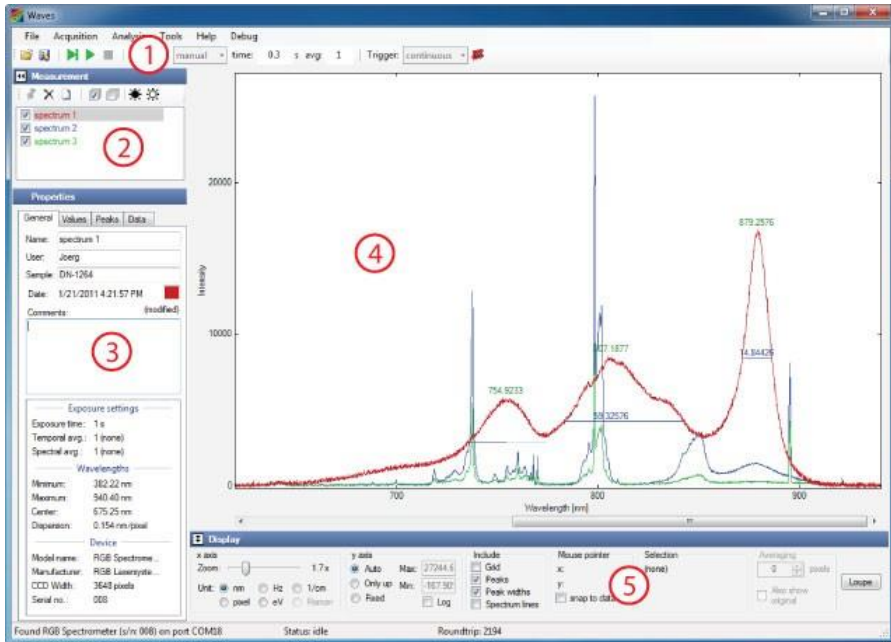

1. Exposure Toolbar: Starts and stops taking spectra and sets the acquisition parameters.
2. Spectrum List: Shows all spectra that are currently in memory.
3. Properties Panel: Consists of five tab pages and displays many parameters and values of the spectrum currently selected in the Spectrum List.
4. Main Diagram Panel: Shows all spectra from the list that are marked with a check mark.
5. Display Parameters Panel: Determines how the spectra are displayed.

Figure 1 Waves Main Interface Window



To create more screen space for the main diagram, minimize the other panels by selecting the triangles next to the panel title.

Taking Spectra

To take a spectrum, choose an exposure time, or select auto-exposure, select one of the green buttons () for a single shot or  to start a continuous measurement). Increase the exposure time to decrease the noise level. If the amount of light detected during the exposure is too large for the CCD detector inside the spectrometer, the spectrum appears saturated and a red OVERLOAD warning appears at the top of the diagram. In this case, decrease the exposure time. Further increase the sensitivity by averaging across multiple exposures with the Averaging setting.

If a spectrum acquisition takes longer than one second, monitor the progress in the status bar at the bottom of the window. The acquisition may finish before the progress indication reaches the end position, because the spectrometer is triggering on the end of the exposure period (see [Triggering and I/O Port on page 33](#) for details). Stop the data acquisition by clicking the red stop button .



For auto-exposure, the exposure time for each new spectrum is set automatically based on the intensity of the previous spectrum. It may take a few spectra before the auto-exposure control has reached its optimum. In auto-exposure mode, set a maximum exposure time to prevent very long exposure times in cases when there is simply no signal.

Spectra can be taken with or without spectral sensitivity correction (see [Calibration on page 29](#) for details). If the lightmeter button  is selected, the spectral sensitivity of the spectrometer is automatically corrected and the intensity axis is measured in a physical unit like nW/nm.

NOTE When taking a spectrum with spectral sensitivity correction, the noise in the spectrum is not evenly distributed because some parts of the spectrum are more amplified than others. Conversely, if this button is not selected, the spectral sensitivity is not corrected and the intensity axis displays values as they are produced by the spectrometer hardware. In this case, an uneven distribution of the sensitivity may be observed across the spectrum. For precise measurements, turn on the spectral sensitivity correction.

The dark spectrum for the spectrometer sensor is stored in the device and automatically used when taking spectra (see [Calibration on page 29](#) for details). For cases with background radiation, compensate for it by taking a background spectrum (see [Absorption, Reflection, and Transmission Measurements on page 27](#)). In the Exposure Toolbar, select the triggering mode (see [Triggering and I/O Port on page 33](#)) and choose a reference spectrum for absorption, reflection, and transmission spectroscopy (see [Absorption, Reflection, and Transmission Measurements on page 27](#)).

Spectrum Display

The Main Diagram Panel displays all spectra that are marked by a checkmark in the Spectrum List. If no spectrum is checked in the list, the currently selected spectrum (marked by a gray bar) is displayed. Check and uncheck all spectra at once by clicking the corresponding buttons,  or , on top of the Spectrum List.

The peaks in the spectra are automatically determined. This not only works reliably for clearly defined peaks, but also for those lying in the side of another peak or those that are just above the noise level. If necessary, fine-tune the parameters for finding the peaks by selecting **Peak Finder Parameters** from the Tools menu. Three settings are available:

- Absolute threshold: Determines how much a peak must be above the noise level to be considered as a peak.
- Relative threshold: Describes how large a peak must be (compared to the local minima before and after it) to be considered as a peak.

- **Position threshold:** Determines how much of the top part of the peak is considered when calculating the peak position.

Peak positions and widths are only displayed for the currently selected spectrum. The peak positions, heights, and widths are also displayed in the Properties panel and can be exported by selecting **Export Peaks** from the File menu.

Use the Display Parameters panel below the diagram to select how the spectra are displayed. These settings affect the diagram display but do not modify the actual data. Change the scaling of both axes, change the unit of the wavelength axis, turn the display of the grid, turn peak positions and peak heights on and off, and see the coordinates of the current position of the mouse pointer.

When zooming into the wavelength axis, a scrollbar appears at the bottom of the diagram for easily moving the displayed part of the spectrum. Alternatively, it is possible to grab and move the axis with the mouse. It is also possible to drag the intensity axis to change the maximum value and quickly enlarge weaker parts of the spectrum.

To determine the intensity value at the position of the mouse pointer relative to a reference value, move the mouse to that reference value, click with the right mouse button, and choose **Set reference level**.

Select a single wavelength or a range of wavelengths by clicking or clicking and dragging within the diagram. This selection can be used to compare wavelength values, display statistical data for this selection (see [Working with Spectra](#)), or to zoom (by right-clicking).

Working with Spectra

In Waves, several spectra can be loaded simultaneously for easy comparison and analysis. The Spectrum list is displayed in the upper left side. Whenever a new spectrum is taken, it appears in this list as current spectrum and overwrites any previous current spectrum. To keep this spectrum and take another one, select the single push-pin button [📌]. This prevents the current spectrum from being overwritten. Any new spectra are then appended to the list. Give the current spectrum a new name to prevent it from being overwritten. Keep all new spectra by selecting the button with multiple push pins [📌] in the Exposure toolbar.

When multiple spectra are in the Spectrum list, one spectrum is always selected (marked by a gray bar). All metadata and additional information for this spectrum display in the Properties panel on the lower left side. The Properties panel contains five tabs:

- **General:** Displays spectrum metadata. Name corresponds to the name in the Spectrum List. User is automatically set to the current Windows user name, but can be changed. Sample, Light, and Comments can be freely edited by the user. Change the color of the spectrum by selecting the color box. Note that User, Sample, Light, and Comments are the same for all spectra in the list. The y-axis property shows the physical quantity and unit that is assigned to the y-axis of the selected spectrum.

When this unit is changed, Waves attempts to convert the data automatically. If this is not possible without further information, a warning is displayed.

- **Values:** Displays statistical values both for the whole spectrum and within the selection (if a range of wavelengths is selected in the diagram).
- **Color:** Displays the most important colorimetric values. Further details are shown in the Colorimetric Analysis windows (see [Tools on page 25](#)). For precise color measurements, see the section on calibration accuracy in [Calibration on page 29](#).
- **Peaks:** Displays peak positions, heights, and widths. This list can be saved to a file by selecting **Export Peaks** from the file menu.
- **Data:** Displays a list of all data values of the spectrum.

Some of the values in the Properties panel are saved when saving the spectrum to a file. The others are recalculated when the spectrum is reloaded.

File Operations

Save

Save the selected spectrum or the whole Spectrum list using the save options in the File menu. The File menu also has options for opening spectrum files to load them back into Waves for further evaluation (many other spectroscopy applications do not support this).

The default file format for spectra is a simple ASCII table with columns delimited by the TAB character and some header lines containing the metadata. This allows the spectrum files saved by Waves to be read by almost any numerical analysis software (such as Origin, Excel, or Matlab). The default file extension for these files is .spz. Double-click a .spz file in Windows Explorer to open the file in the Waves application.

To save disk space, save the data in a compressed format by selecting **Save data as compressed zip files** from the Options windows. The saved spectrum file is then a zip archive (still with the .spz file extension). To retrieve the spectrum data from this file without using Waves, change the file extension to .zip and unpack the file like any other zip archive.

In Waves, spectrum data files written by other applications can also be opened if they are saved as ASCII tables or .csv files. Waves tries to automatically determine the file structure and can open many different file formats.

Print

Print spectra by selecting **Print** from the file menu. Select the **Landscape** page orientation to print spectrum diagram across the whole page. Choose the **Portrait** page orientation to

print the diagram on the upper half of the page. The lower half of the page shows selected metadata and values.

The printing options are designed for the most common tasks. For further specific requirements for printing, export the diagram and then use a graphical design software or word processor for printing.

Export

Export a diagram as either a bitmap image or a PDF vector graphic. Both options are available by choosing **Export** from the File menu.

After choosing a file name, set the height and width of the image and the resolution, if applicable. Note that text size and line width are constant. Therefore, labels and line widths appear smaller when a larger export size is selected.

Spectrum Calculations

The Modify menu offers several ways to evaluate and modify spectra.

Adjust Offset

Adjust Offset adds a constant value to all data points of the selected spectrum. The software suggests an estimated value for compensating an offset, but any other value may be chosen. It is also possible to adjust the offset for all spectra in the list.

Normalize

Normalize multiplies all data points of the selected spectrum by a constant factor. The default factor is chosen for the maximum value to be scaled to 100. Again, it is possible to adjust the offset for all spectra in the list.

Differentiate

The Differentiate option differentiates the spectrum with respect to the wavelength.

Apply Smoothing

Apply Smoothing substitutes each data point by the average of the surrounding data points. Choose the number of data points to include in the averaging and which algorithm to use, including Savitzky-Golay smoothing. Rectangular smoothing is also known as *boxcar averaging*.

Alternatively, it is possible to turn on smoothing in the display parameters panel below the spectrum diagram. This setting applies only to the way the spectra are displayed and does not change the actual data.

NOTE Smoothing makes the data less precise, not more precise. Smoothing is intended to make a spectrum easier to understand for readers and does not provide any additional features in the spectrum that were not already there.

Correct Baseline

If a spectrum has several sharp peaks on top of a broad background signal, the Correct Baseline feature subtracts the background signal. This is especially useful to eliminate the broad fluorescence background in Raman spectra.

Duplicate

The Duplicate feature creates a copy of the selected spectrum and may be useful for modifying a spectrum while keeping the original one.

Arithmetic Operations

Arithmetic Operations create a new spectrum by adding, subtracting, multiplying, or dividing two spectra.

Add Average Over All/Visible Spectra

The Add Average Over All/Visible Spectra option calculates the average spectrum of all spectra in the list (or just the visible ones).

Create New Wavelength Scale

The Create New Wavelength Scale option creates a new wavelength scale based on a given start and end wavelength and step width and interpolates all spectra accordingly.

Tools

Strip Chart

Use the Strip Chart tool to display a characteristic property of the spectrum as a function of another property for all spectra in the list. The most common task is to display the temporal evolution of a characteristic value. This window can be kept open while taking new spectra to observe changes as they happen.

In the lower left side of the Strip Chart window, choose which values to assign to the x and y axis of the chart. All numerical values that are displayed in the Properties Panel are available. To view the temporal evolution of a value, choose this value for the y axis and either **Number in List** or **Time** for the x axis.

If **Value from name** is selected as the x or y axis, the software parses the name of each spectrum into a number. For example, if a list of spectra are named T = 10.3°C, T = 15.2°C, and so on, these temperature value are used for the corresponding axis.

In the Strip Chart diagram, the currently selected spectrum is marked by a slightly larger point. Points corresponding to spectra that are currently not visible in the main window are drawn in a lighter red color.

Loupe

Loupe opens a window with a magnified display of the spectrum around the mouse pointer. It may be used to study small features in the spectrum as an alternative to zooming.

Colorimetric Analysis

The Colorimetric Analysis window shows more detailed colorimetric values than the small panel in the main window. All colorimetric values are calculated according to CIE standards.

NOTE There are several settings in the Options window that are used for calculating colorimetric values, like color spaces and reference functions.

Add Reference Spectra

Add Reference Spectra shows all reference spectra used for colorimetric analysis. It is also possible to add a black body spectrum of a certain temperature.

Peak Width Diagram

Peak Width Diagram opens a window displaying the widths of the detected peaks (full width at half maximum).

Absorption, Reflection, and Transmission Measurements

Principle

In absorption, reflection, and transmission spectroscopy, light is directed from a broadband light source onto a sample. Then, a spectrum, $I(\lambda)$, is taken of the light transmitted through or reflected from the sample. To get meaningful results independent of the light source a spectrum is also taken of the light source without the sample as a reference, $I_0(\lambda)$.

The spectral transmittance $T(\lambda)$ or reflectance is then simply the fraction of transmitted or reflected light:

$$T(\lambda) = \frac{I(\lambda)}{I_0(\lambda)}$$

This formula returns values ranging between 0 and 1. The transmittance is usually written as a percentage. The spectral absorbance, $A(\lambda)$, is defined as:

$$A(\lambda) = \log \frac{I_0(\lambda)}{I(\lambda)}$$

NOTE The absorbance is sometimes defined as the base-10 logarithm and sometimes as the natural (base e) logarithm. In Waves, both options are available.

Measurement

To measure absorption, reflection, or transmission, first take a reference spectrum of the light source. If the measurement setup is not in complete darkness, take a background spectrum before the measurement.

To take a background spectrum, turn off the light source, set an appropriate exposure time, and click **Take Background Spectrum** [📷] on the Exposure toolbar. To minimize noise, temporal averaging is recommended. If a background spectrum has been taken, select **Use Background Spectrum** [📷]. If a spectrum is taken afterwards, the background spectrum is automatically subtracted from the measured spectrum, eliminating unwanted background signals.

To take a reference spectrum for transmission or absorption spectroscopy, turn on the light source again, remove the sample, set an appropriate exposure time and temporal averaging, and click **Take Reference Spectrum** [📷]. After selecting **Use Reference Spectrum**, take spectra of the sample for measuring absorption or transmission.

To take a reference spectrum for reflection spectroscopy, a white reference sample is required to calibrate the setup for 100% reflection. However, all real-world reference samples have a reflection of less than 100% and an uneven spectral distribution. Therefore, for accurate measurements a reference spectrum must be supplied for the reference sample. To take a reference spectrum, place the white reference sample where the measured sample will be later placed. Then, set an appropriate exposure time and temporal averaging and click **Take Reference Spectrum** [📷]. In the following dialog window, specify a data file that includes a calibrated spectrum of your reference sample. After selecting **Use Reference Spectrum** [📷] measure reflectivity spectra.

The y-axis of the spectrum now shows the relative intensity of the measured spectrum compared to the reference spectrum. In the **Options** panel from the File menu, select different units for displaying the spectra. The y-axis unit can be changed later from the Properties panel.

If the light source does not cover the full range of the spectrometer, the calculated spectrum may show large amounts of noise outside of the wavelength range of the light source. This is normal and reflects the fact that the measurement has a large uncertainty at these wavelengths.

These measurements are quite sensitive to changes of the sample illumination. If in doubt, take another reference spectrum to ensure it is still valid.

Calibration

The calibration for the wavelengths, dark spectrum, nonlinearity, and spectral sensitivity are stored in the device and loaded automatically during device initialization. In contrast to

almost any other spectroscopy software, it is not required to take dark spectra and other calibration parameters—they are done automatically.

If the device has been used for a long time or if a very precise measurement is required, recalibrate the spectrometer with Waves and a suitable light source. Recalibration may also be required if the device temperature is outside of the calibrated temperature range. The device temperature is continuously monitored by the spectrometer and a warning displays if the temperature changes considerably.

After recalibrating the spectrometer, restore the factory calibration at any time from the **Device Configuration** panel in the File menu.

Calibration Accuracy

The wavelength calibration is very accurate and changes very little with time or temperature. Therefore, most users will not require wavelength recalibration. The nonlinearity also hardly changes with time or temperature.

The dark spectrum calibration depends significantly on the temperature and the exposure time. These dependencies are automatically taken into account and compensated, and should not affect testing. However, if in doubt or if as little noise as possible is a test requirement, recalibrating the dark spectrum is easy because no calibration light source is required.

The calibration for the spectral sensitivity depends mainly on the optical fiber, the measurement probe, and how the light is coupled into the spectrometer. During production of the spectrometer, the user's optical setup is unknown. Therefore, the factory calibration for the spectral sensitivity and especially the absolute intensity should not to be considered a precise reference, but rather a first estimate. If precise intensity measurements are required, recalibrate the sensitivity of the whole system, including fiber and probe.

In addition, note that after changing the exposure time it takes a few spectra before the CCD sensor inside the spectrometer reaches its new equilibrium. This means that after changing the exposure time, the intensities of the following 5 to 10 spectra may not be as accurate as later measurements. Therefore, do not use the auto-exposure feature for precise measurements—set a fixed exposure time instead.

Wavelengths

Mapping of the individual pixels of the spectrum to wavelengths is done using a third-order polynomial. The four coefficients for this function are measured during manufacturing and stored in the device. Usually, this wavelength calibration does not change. Therefore, in most cases wavelength recalibration is not needed. However, if the ambient temperature has changed substantially, if the device has been used for a very long time, or to verify the

wavelengths are still correct, recalibrate the wavelengths with a suitable light source with several sharp atomic emission lines. These wavelength calibration sources are usually low-pressure gas discharge lamps filled with Krypton, Neon, Mercury, Argon, or Xenon gas.

To recalibrate, take a spectrum of this light source first. Ensure that the relevant peaks are automatically detected. If not, adjust the **Peak Finder Parameters** in the Tools Menu. Then, choose **Calibrate Wavelengths** from the Calibration menu. In the Light source combo box, select the type of light source being used. If the light source is not in the list, supply custom calibration lines. In this case, refer to the *CalibrationLines xxx.dat* files in the installation folder on your hard drive and create a new similar file containing the spectrum lines of your light source.

After selecting the light source, click **Start**. The software attempts to match the peaks in the measured spectrum to the given spectrum lines for the light source. If a match is found, the average deviation displays. If the match seems to be successful, it displays in green, otherwise in red. If the measured peaks have successfully been identified, save the four new wavelength calibration parameters to the device by clicking **OK**.

Dark Spectrum

Inside the spectrometer, the spectra are detected with a CCD or CMOS line image sensor. Like all image sensors, this sensor detects a small signal even if there is no light entering the spectrometer. This signal depends on the individual pixel, exposure time, and temperature. To obtain a precise measurement with a small noise level, this Dark Spectrum must be recorded while no light enters the spectrometer and then subtracted from the actual measurement.

For the Qred spectrometer, this dark spectrum has already been taken. It is stored in the device as a series of dark spectra for different exposure times together with temperature coefficients. During measurement, a dark spectrum for the current exposure time and temperature is automatically calculated and subtracted from the measured spectrum.

To recalibrate the dark spectra, close the spectrometer entrance, ensure that no light enters the device, and choose **Calibrate Dark Spectrum** from the Tools menu. Then, click **Take**. Check the new dark spectra by clicking **Test**. While the test is running, observe the spectra taken without (red) and with (green) dark spectrum correction in the lower diagram. In the upper diagram observe the noise level, also without (red) and with (green) dark spectrum correction for a series of exposure times. Observe that the noise level of the raw data (red) increases significantly with increasing exposure time. With dark spectrum correction (green) however, the noise level should remain approximately at the same level for exposure times less than 1 second and increase slower for exposure times larger than 1 second. If this is the case, close the window by clicking **OK**. The new dark spectrum calibration is saved into the device. Otherwise, recalibrate or click **Cancel**.

Spectral Sensitivity

Like all spectrometers, the sensitivity of the Qred spectrometer is not uniform across the spectrum, but depends on the wavelength. This is called *spectral sensitivity* and can be corrected by dividing each value of the spectrum by the corresponding sensitivity. This sensitivity calibration is also stored in the device. However, it is not always used when taking spectra because if the sensitivity is corrected, the noise level is unevenly distributed across the spectrum. Instead, choose spectral sensitivity correction by selecting **lightmeter** in the Exposure toolbar.

To recalibrate the spectral sensitivity, use a light source with a continuous spectrum (like a tungsten halogen lamp) and a spectrum file containing the actual spectrum for this lamp.

To recalibrate, choose **Calibrate Spectral Sensitivity** from the Tools menu. Connect the light source to the spectrometer and click **Take Spectrum**. When the spectrum is taken, click **Load reference data** to load the calibrated reference spectrum (meaning, a spectrum file that shows what the light source really looks like). Based on the measured spectrum and this file, the software calculates the spectral sensitivity of the spectrometer and shows it as a dark green line. To save this new calibration to the device, click **OK**. Enter the physical unit of the y-axis of the corrected spectra along with a description.

To calibrate the absolute scale of the intensity axis, take a spectrum and also determine the absolute optical power (in watts) of this spectrum. When measuring the actual optical power with an optical power meter, ensure that the power meter only detects wavelengths that are within the wavelength range of the spectrometer (for example by choosing a suitable light source). Then, choose **Calibrate power** from the Tools menu and enter the actual power. Click **OK**. The new power calibration is stored in the device and used for scaling the intensity axis. This axis then displays the spectral power density in the physical unit specified in the Calibrate Spectral Sensitivity window.

In addition, it is possible to calibrate the power not just with respect to the spectrometer entrance, but also to any other point in the optical setup. For instance, it is possible to calibrate the power that enters the measurement probe or any other power in the test setup, as long as it is proportional to the power that enters the spectrometer. Note that the optical powers and power densities displayed by the software refer to this value.

Nonlinearity

In an ideal spectrometer, the measured spectrum is exactly proportional to the incoming light intensity. All real spectrometers, however, exhibit certain nonlinear deviations. As an example, this means that reducing the light intensity by one half may not return exactly half the measured spectrum. Fortunately, this nonlinearity can be described by a polynomial function and corrected within the software.

The nonlinearity of each Qred spectrometer is calibrated during production and automatically corrected. This calibration hardly changes with time or temperature and should not be a factor in testing.

However, to check or recalibrate the nonlinearity calibration open the Calibrate Nonlinearity window. A stable broadband light source with a smooth spectrum is required, like a tungsten or LED lamp. Connect the lamp and click **Take** to recalibrate the nonlinearity or **Test** to check it.

Triggering and I/O Port

Trigger Options

Spectra are generally taken after clicking one of the green buttons ([▶] or [▶]) in the Exposure toolbar. It is also possible to set the spectrometer to wait for an event before taking a spectrum. This is called Triggering. In the Exposure toolbar, select one of three trigger modes:

- Continuous: Spectra are taken as soon as possible.
- Interval: Spectra are taken in regular time intervals. Specify the time between two spectra and also a time period after which the measurement is stopped. The timer progress is shown in the status bar. Obviously, this trigger mode does not apply to single-shot measurements.
- External: Spectra are taken after the input voltage on one of the external I/O channels has changed. Use this to synchronize the exposure to other devices or external events.

In the Device Configuration window, additional trigger options are available. These trigger options apply to external as well as to internal (continuous and interval) trigger modes.

- Trigger on end of exposure: This is the default mode. The spectrometer is continuously taking spectra and when the trigger event occurs, the current spectrum is read out. This causes a random trigger delay between zero and the exposure time.
- Trigger on start of exposure: The spectrometer is continuously taking spectra and when the trigger event occurs, the next spectrum after the one currently being taken is read out. Choose this mode to ensure that no light is collected for the spectrum before the trigger event occurs or before the button is clicked. This mode requires more time to take a spectrum. It also causes a random trigger delay between zero and the exposure time.

For external triggering, there are additional options described below.

I/O Channels

The spectrometer includes four digital I/O pins on the front-side auxiliary connector, which can be configured as trigger input, shutter or flash lamp control, process control, or general purpose I/O pins. Configure the channels in the Device Configuration window. See [Specifications on page 36](#) for the pin assignments of the external connector.

To use a channel as an external trigger source, perform the following steps:

1. Set this pin to **Input**.
2. Set the trigger pin number.
3. Select either Falling Edge (trigger occurs when the input voltage drops from 3.3V to 0V) or Rising Edge (trigger occurs when the voltage rises from 0V to 3.3V).

Chapter 4: Software Development Kit

The CD-ROM includes a Software Development Kit (SDK) for the spectrometer that can be used to control it and take spectra from additional custom software. The SDK includes a Windows Dynamic Link Library (DLL) for the .NET framework, documentation, and sample code.

Alternatively, it is possible to directly communicate with the spectrometer from custom software including embedded systems. See the communication protocol manuals in the SDK for additional details.

Chapter 5: Technical Support

Getting Help

For any questions, comments, or requests concerning the spectrometer or the Waves software, go to www.broadcom.com and click **Support** from the menu bar. There details on how to contact our Technical Support Team via e-mail or telephone.

Software Updates

Software updates are usually released at least twice a year. Find the latest version on our website.

Chapter 6: Specifications

Qwave

Table 1 Qwave Specifications

Specification	Value
Optical	
Focal length	75 mm
Numerical Aperture	0.10
Entrance slit	20 μm
Spectral resolution FWHM	VIS: 0.5 nm
	UV: 0.2 nm
	NIR: 0.4 nm
Stray light	< 0.05%
Optical interface	SMA connector
Electronic	
Dynamic range	2000:1 (full scale, $t_{exp} = 1s$)
Detector	3648 pixel linear CCD detector (VIS, UV: coated for enhanced UV detection)
A/D converter	16-bit 15 MHz
Calibration	Wavelength, sensitivity, and multiple dark spectra stored within device
Digital Interface (Qwave 1)	USB 2.0 with Mini-USB connector
Digital Interface (Qwave 2)	USB 2.0 with Type-C connector, UART (serial), I ² C
Extension port	4 General purpose I/O channels
	Configurable as trigger input
	Digital interface for accessories
Power supply	5V DC via USB (no power adapter required)
Power consumption	Typical: 180 mA, Maximum: 500 mA (with accessory)
PC operating system	Windows 7, Vista, XP
Mechanical	
Dimensions	89.5 mm x 68.0 mm x 19.5 mm
Weight	155g

Specification	Value
Operating temperature	-15°C to 60°C (non-condensing)
Storage temperature	-25°C to 70°C

Figure 2 Qwave Technical Drawing

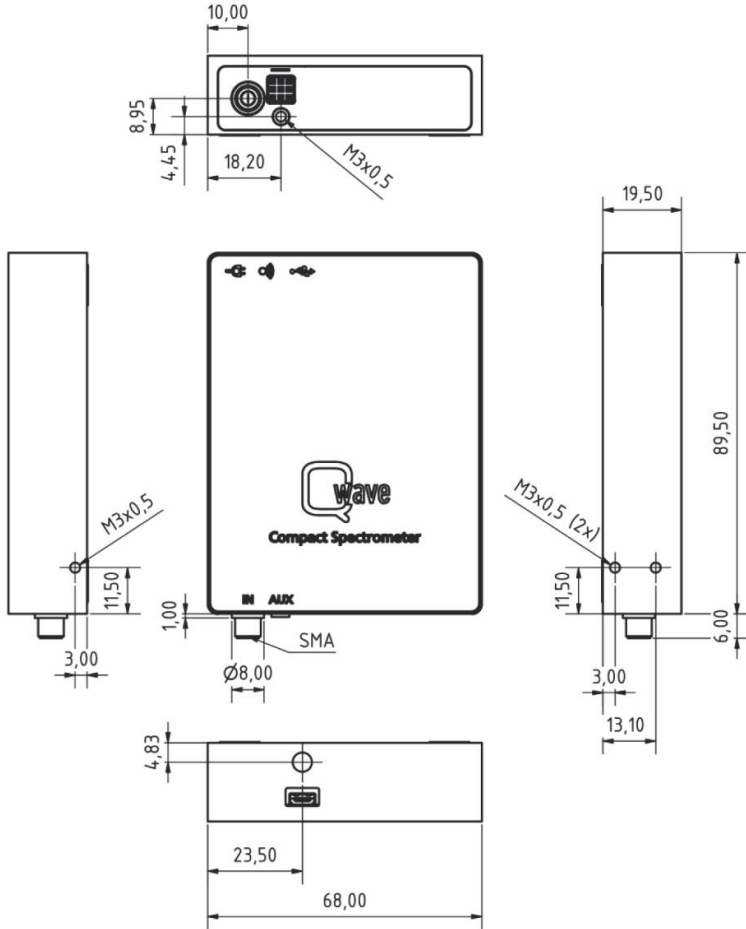

All dimensions in mm.

Qmini

Table 2 Qmini Specifications

Specification	Value
Optical	
Focal length	50 mm
Numerical Aperture	0.1
Grating	300 or 600 lines/mm
Entrance slit	20 μm (can be changed by user)
Spectral resolution FWHM	≥ 0.3 nm
Stray light	< 0.1%
Optical interface	SMA connector
Electronic	
Dynamic range	500:1 (full scale, $t_{exp} = 1s$)
Detector	2500 pixel linear CCD detector
A/D converter	16-bit
Calibration	Wavelength, sensitivity and dark spectrum stored within device
Digital Interfaces	USB 2.0 with Type-C connector, UART (serial), SPI, I ² C
Extension port	4 General purpose I/O channels
	Configurable as trigger input
	Digital interface for accessories
Power supply	5V DC via USB (no power adapter required)
Power consumption	Up to 130 mA
PC operating system	Windows 10, 8, 7, Vista, XP
Mechanical	
Dimensions	64.0 mm × 42.0 mm × 14.5 mm
Weight	60g
Operating temperature	-15°C to 60°C (non-condensing)
Storage temperature	-25°C to 70°C

Figure 3 Qmini Technical Drawing

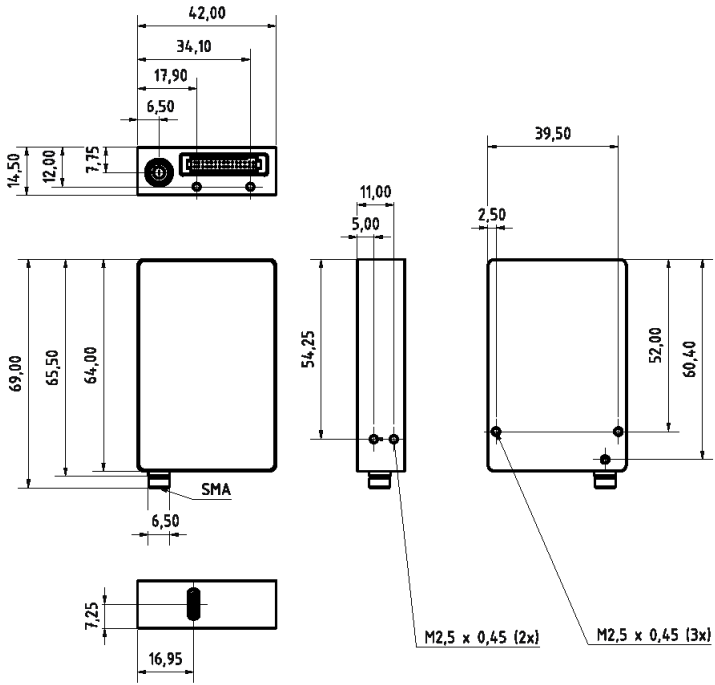

All dimensions in mm. 3D CAD files are available for download.

Qred

Table 3 Qred Specifications

Specification	Value
Optical	
Focal length	50 mm
Numerical Aperture	0.14
Grating	220 lines/mm
Entrance slit	20 μm (can be changed)
Spectral resolution FWHM	≥4.0 nm (depending on configuration)
Stray light	<0.1%
Optical interface	SMA connector
Electronic	
Dynamic range	15000:1
Detector	Cooled 256 or 512-pixel InGaAs line sensor
A/D converter	16-bit
Calibration	Wavelength, sensitivity, dark spectrum, and nonlinearity stored within device
Digital Interfaces	USB 2.0 with Type-C connector, others on request
Extension port	4 General purpose I/O channels
	Configurable as trigger input
	Digital interface for accessories
Power supply	5V DC via USB or 5V to 12V via Aux Connector
Power consumption	200 mA (without cooling), up to 3A (with cooling)
PC operating system	Windows 10, 8, 7, Vista, XP
Mechanical	
Dimensions	64.0 mm × 58.0 mm × 22.5 mm
Weight	160g
Operating temperature	-15°C to 60°C (non-condensing)
Storage temperature	-25°C to 70°C

Figure 4 Qred Technical Drawing

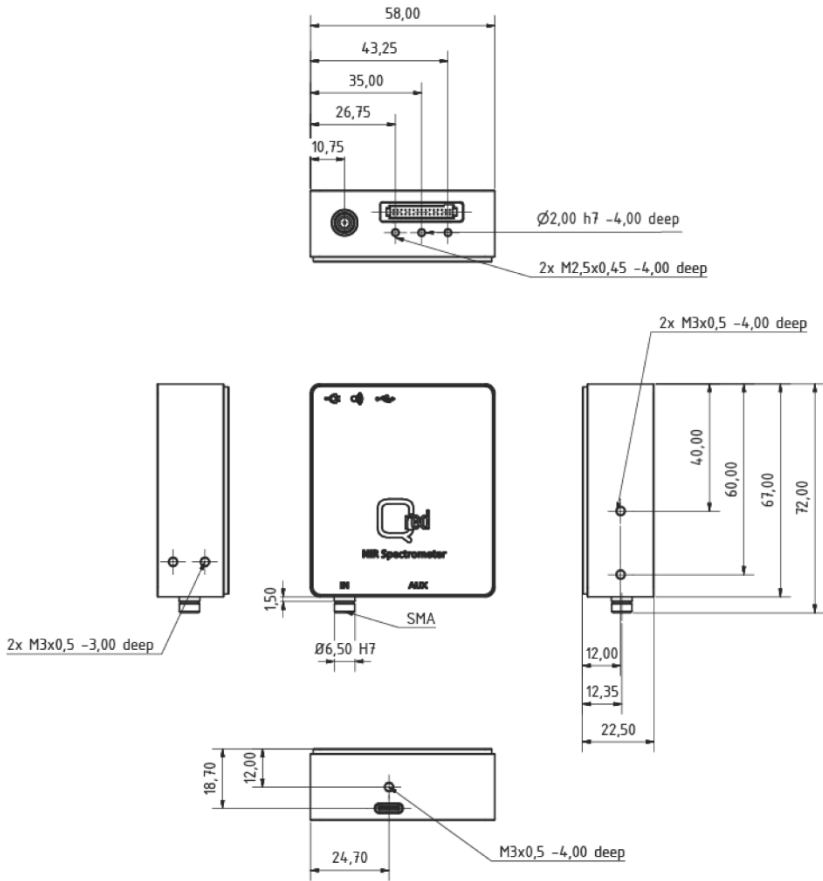

All dimensions in mm. 3D CAD files are available on request.

Pin Assignment

9-Pin Auxiliary Interface

Pins 4, 5, and 6 are only present on the square connector on the device and only intended for communication with optional accessories. Do not use these pins.

All other pins are also present on the optional I/O port adapter. Use these pins for trigger input and general-purpose I/O. Use the power supply on pin 1 to supply small custom electronics.

Figure 5 9-Pin Auxiliary Interface

1	4	7
2	5	8
3	6	9

1	2	3	7	8	9
---	---	---	---	---	---

Qwave Extension Port
(Connector viewed towards front side of device)

I/O Port Adapter
(Screw terminal block viewed towards front side of device)

Qwave 1 Pins

1. +5V Power Supply (max. 300 mA)
2. I/O Pin 0
3. I/O Pin 1
4. Extension Present (for accessories)
5. Digital Interface SCL (for accessories)
6. Digital Interface SDA (for accessories)
7. I/O Pin 2
8. I/O Pin 3
9. Ground

Qwave 2 Pins

1. +5V alternative input power supply
2. I/O Pin 0
3. I/O Pin 1
4. Reset (low active)
5. Digital Interface I²C -SCL/UART RXD
6. Digital Interface I²C -SDA/UART TXD
7. I/O Pin 2
8. I/O Pin 3
9. Ground

30-Pin Auxiliary Interface

This connector on the front side of the spectrometer is a Samtec TFM-115-02-L-D-WT. Either obtain the optional I/O port adapter for the Qred or design a custom accessory.

ATTENTION The notch in the upper right corner of the connector does not indicate the position of pin 1.

Figure 6 30-Pin Auxiliary Interface

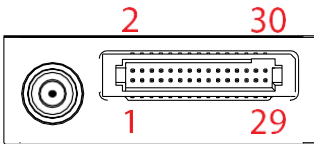

Compatible Samtec mating connectors include:

- SMT right-angle: SFM-115-02-L-DH-TR
- SMT straight: SFM-115-02-S-D-LC
- SMT straight: SFMC-115-02-L-D (no alignment)
- SMT straight: SFMC-115-L2-L-D (no alignment, Low Insertion Force)
- SMT straight: SFM-115-L2-S-D-SN
- Through-Hole: SFMC-115-[xx]-L-D-(SMT)
- Wires: ISDF-15-D-M + CC03R-2830-01-G

See below for a description of all interface pins. Contact us for additional information on the auxiliary interface.

CAUTION All logic levels are 0V/3.3V (except power supply and USB). Do not connect any interface pin directly to the 12V power supply.

Table 4 Interface Pin Descriptions

Pin Number	Signal Name	Alternative Function	Type	Description
1	+12V_AUX_IN	—	PWR	Power input
2	USB_DN	—	IO	USB bidirectional D- line
3	GND	—	PWR	Ground
4	USB_DP	—	IO	USB bidirectional D+ line
5	VBUS	—	I	VBUS pin (power on USB cable)
6	UART_RXD	GPIO	I	Receiver input for UART
7	UART_TXD	GPIO	O	Transmitter output for UART
8	UART_CTS	GPIO	I	Clear to Send input for UART
9	UART_RTS	GPIO	O	Request to Send output for UART
10	GND	—	PWR	Ground
11	SPI_MISO	GPIO	I	Master In Slave Out for SPI
12	SPI_CS	GPIO	O	Slave Select for SPI
13	SPI_SCK	GPIO	O	Serial clock for SPI
14	SPI_MOSI	GPIO	O	Master Out Slave In for SPI
15	GND	—	PWR	Ground
16	RESEnTn	—	I	Reset is low active (to reset device keep low for >1 ms)
17	TRIG_IO_0	GPIO/PWM	IO	Low-latency trigger input/output
18	TRIG_IO_1	GPIO/PWM	IO	Low-latency trigger input/output

Pin Number	Signal Name	Alternative Function	Type	Description
19	TRIG_IO_2	GPIO/PWM	IO	Low-latency trigger input/output
20	TRIG_IO_3	GPIO/PWM	IO	Low-latency trigger input/output
21	GND	—	PWR	Ground
22	I2C_SCL	GPIO	IO	I ² C clock input/output
23	I2C_SDA	GPIO	IO	I ² C data input/output
24	CAN_TD	GPIO	O	CAN transmitter output
25	CAN_RD	GPIO	I	CAN receiver input
26	GND	—	PWR	Ground
27	DAC	—	O	10-bit digital-to-analog converter
28	ADC	—	I	10-bit analog-to-digital converter
29	GND	—	PWR	Ground
30	+5V_AUX_OUT	—	PWR	Power output (300 mA max.)

Chapter 7: Certifications and Compliance

Figure 7 CE Declaration of Conformity

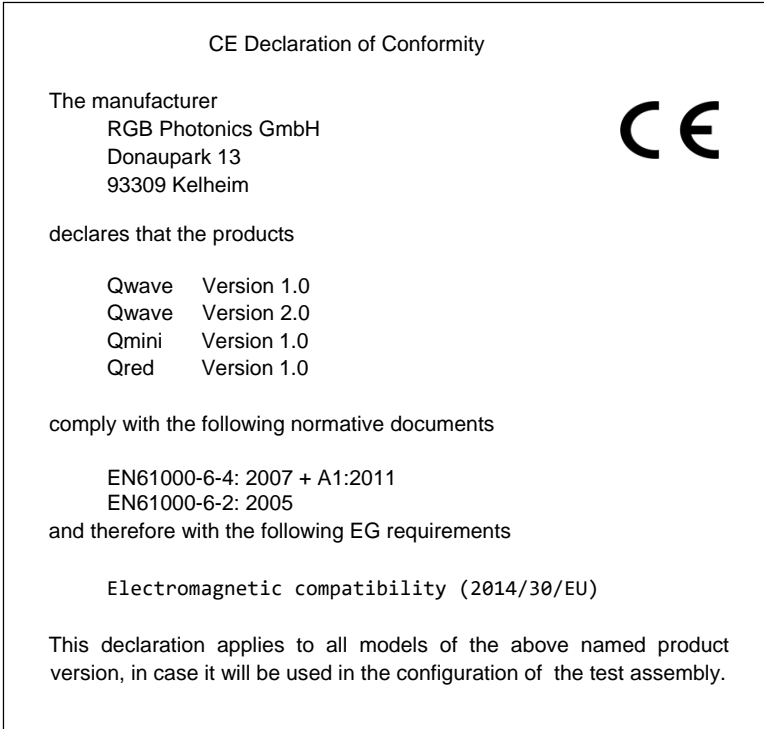

Figure 8 FCC Compliance

FCC Compliance

This declaration applies to the following products:

Qwave	Version 1.0
Qwave	Version 2.0
Qmini	Version 1.0
Qred	Version 1.0

This device complies with part 15 of the FCC Rules. Operation is subject to the following two conditions: (1) This device may not cause harmful interference, and (2) this device must accept any interference received, including interference that may cause undesired operation.

This equipment has been tested and found to comply with the limits for a Class A digital device, pursuant to Part 15 of the FCC Rules. These limits are designed to provide reasonable protection against harmful interference when the equipment is operated in a commercial environment. This equipment generates, uses and can radiate radio frequency energy and, if not installed and used in accordance with the instruction manual, may cause harmful interference to radio communications. Operation of this equipment in a residential area is likely to cause harmful interference in which case the user will be required to correct the interference at his own expense.

Figure 9 RoHS Declaration of Conformity

RoHS Declaration of Conformity

The manufacturer
RGB Photonics GmbH
Donaupark 13
93309 Kelheim

declares that the products

Qwave	Version 1.0
Qwave	Version 2.0
Qmini	Version 1.0
Qred	Version 1.0

contains no toxic substances which are specified in the
RoHS Directive 2011/65/EU.

The conformity to RoHS Directive 2011/65/EU is confirmed.
This declaration applies to all models of the above named product
version.

Revision History

AFBR-Spectro-UG100; October 12, 2018

Initial release.

