

Description

The LM2901/2903 series comparators consist of four and two independent precision voltage comparators with very low input offset voltage specification. They have been designed to operate from a single power supply over a wide range of voltages; however operation from split power supplies is also possible. They offer low power supply current independent of the magnitude of the power supply voltage.

The LM2901/2903 series comparators are designed to directly interface with TTL and CMOS. When operate from both plus and minus power supplies, the LM2901/2903 series comparators will directly interface with MOS logic where their low power drain is a distinct advantage over standard comparators.

The dual devices are available in SO-8 and the quad devices available in SO-14 and TSSOP-14 with industry standard pinouts. Both use green mold compound as standard.

Features

- Wide power supply range:
 - Single supply: 2V to 36V
 - Dual supplies: $\pm 1.0V$ to $\pm 18V$
- Very low supply current drain— independent of supply voltage
 - LM2903: 0.6mA
 - LM2901: 0.9mA
- Low input bias current: 25nA
- Low input offset current: $\pm 5nA$
- Typical offset voltage:
 - Non-A device: 2mV
 - A device: 1mV
- Common-mode input voltage range includes ground
- Differential input voltage range equal to the power supply voltage
- Low output saturation voltage:
 - LM2903: 200mV at 4mA
 - LM2901: 100mV at 4mA
- Output voltage compatible with TTL, MOS and CMOS
- **Totally Lead-Free & Fully RoHS Compliant (Notes 1 & 2)**
- **Halogen and Antimony Free. "Green" Device (Note 3)**

- Notes:
1. No purposely added lead. Fully EU Directive 2002/95/EC (RoHS) & 2011/65/EU (RoHS 2) compliant.
 2. See http://www.diodes.com/quality/lead_free.html for more information about Diodes Incorporated's definitions of Halogen- and Antimony-free, "Green" and Lead-free.
 3. Halogen- and Antimony-free "Green" products are defined as those which contain <900ppm bromine, <900ppm chlorine (<1500ppm total Br + Cl) and <1000ppm antimony compounds.

Pin Assignments

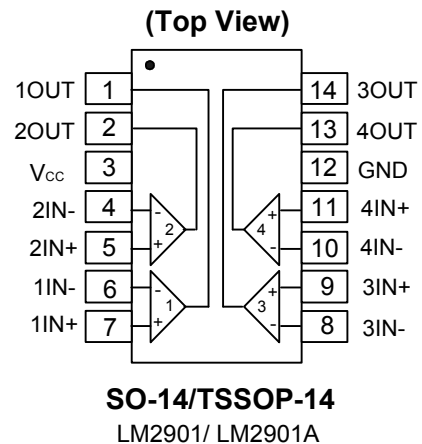
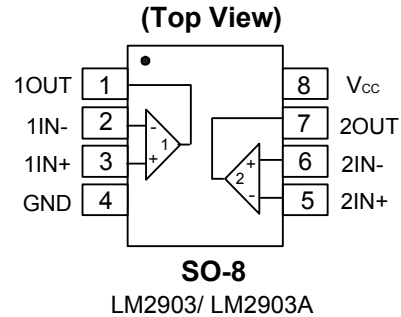

Schematic Diagram

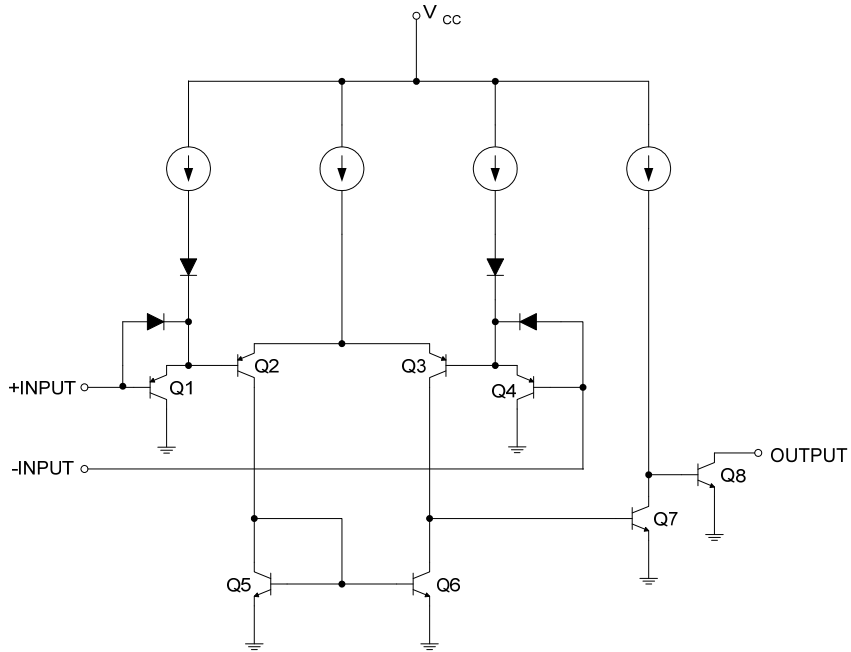

Functional Block Diagram of LM2901/2901A/2903/2903A
(Each Comparator)

Pin Descriptions

LM2901, LM2901A		
Pin Name	Pin #	Function
1OUT	1	Channel 1 Output
2OUT	2	Channel 2 Output
V _{CC}	3	Chip Supply Voltage
2IN-	4	Channel 2 Inverting Input
2IN+	5	Channel 2 Non-inverting Input
1IN-	6	Channel 1 Inverting Input
1IN+	7	Channel 1 Non-inverting Input
3IN-	8	Channel 3 Inverting Input
3IN+	9	Channel 3 Non-inverting Input
4IN-	10	Channel 4 Inverting Input
4IN+	11	Channel 4 Non-inverting Input
GND	12	Ground
4OUT	13	Channel 4 Output
3OUT	14	Channel 3 Output
LM2903, LM2903A		
1OUT	1	Channel 1 Output
1IN-	2	Channel 1 Inverting Input
1IN+	3	Channel 1 Non-inverting Input
GND	4	Ground
2IN+	5	Channel 2 Non-inverting Input
2IN-	6	Channel 2 Inverting Input
2OUT	7	Channel 2 Output
V _{CC}	8	Chip Supply Voltage

Absolute Maximum Ratings (Note 4) (@T_A = +25°C, unless otherwise specified.)

Symbol	Parameter	Rating	Unit
V _{CC}	Supply Voltage	36	V
V _{ID}	Differential Input Voltage	36	V
V _{IN}	Input Voltage	-0.3 to +36	V
I _{IN}	Input Current (V _{IN} < -0.3V)	50	mA
V _O	Output Voltage	36	V
I _O	Output Current	20	mA
—	Duration of Output Short Circuit to Ground (Note 5)	Unlimited	—
θ _{JA}	Package Thermal Impedance (Note 6)	SO-8	TBD
		SO-14	TBD
		TSSOP-14	TBD
θ _{JC}	Package Thermal Impedance (Note 6)	SO-8	TBD
		SO-14	TBD
		TSSOP-14	TBD
T _A	Operating Temperature Range	-40 to +125	°C
T _J	Operating Junction Temperature	150	°C
T _{ST}	Storage Temperature Range	-65 to +150	°C
T _{LEAD}	Lead Temperature (Soldering, 10 seconds)	260	°C
ESD	Human Body Mode ESD Protection (Note 7)	500	V
	Machine Mode ESD Protection	100	

- Notes:
- Stresses beyond those listed under absolute maximum ratings may cause permanent damage to the device. These are stress ratings only; functional operation of the device at these or any other conditions beyond those indicated under recommended operating conditions is not implied. Exposure to absolute-maximum-rated conditions for extended periods may affect device reliability.
 - Short circuits from outputs to V_{CC} can cause excessive heating and eventual destruction.
 - Maximum power dissipation is a function of T_{J(MAX)}, θ_{JA}, and T_A. The maximum allowable power dissipation at any allowable ambient temperature is P_D = (T_{J(MAX)} - T_A)/θ_{JA}. Operating at the absolute maximum T_J of 150°C can affect reliability.
 - Human body model, 1.5kΩ in series with 100pF.

Electrical Characteristics (Notes 8 & 9) (@ $V_{CC}=5.0V$, $GND=0V$, $T_A = +25^\circ C$, unless otherwise specified.)

LM2901, LM2901A								
Parameter		Conditions		T_A	Min	Typ	Max	Unit
V_{IO}	Input Offset Voltage	$V_{IC} = V_{CMRmin}$, $V_O = 1.4V$, $V_{CC} = 5V$ to $30V$ (Note 10)	Non-A Device	$T_A = +25^\circ C$	—	2	7	mV
				Full range	—	—	15	
			A-Suffix Device	$T_A = +25^\circ C$	—	1	2	
				Full range	—	—	4	
I_B	Input Bias Current	I_{IN+} or I_{IN-} with OUT in linear range, $V_{CM} = 0V$ (Note 11)		$T_A = +25^\circ C$	—	25	250	nA
				Full range	—	—	500	
I_{IO}	Input Offset Current	$I_{IN+} - I_{IN-}$, $V_{CM} = 0V$		$T_A = +25^\circ C$	—	5	50	nA
				Full range	—	—	200	
V_{CMR}	Input Common-Mode Voltage Range	$V_{CC} = 30V$ (Note 12)		$T_A = +25^\circ C$	0 to $V_{CC}-1.5$	—	—	V
				Full range	0 to $V_{CC}-2$	—	—	
I_{CC}	Supply Current (Four Comparators)	$R_L = \infty$ on quad channels	$V_{CC} = 30V$	$T_A = +25^\circ C$	—	1.2	2.5	mA
				Full range	—	—	3.5	
			$V_{CC} = 5V$	$T_A = +25^\circ C$	—	0.9	2	
				Full range	—	—	3.0	
A_V	Voltage Gain	$V_{CC} = 15V$, $V_{OUT} = 1V$ to $11V$, $R_L \geq 15k\Omega$,		$T_A = +25^\circ C$	50	200	—	V/mV
—	Large Signal Response time	$V_{IN} = TTL$ logic swing, $V_{REF} = 1.4V$, $V_{RL} = 5V$, $R_L = 5.1k\Omega$		$T_A = +25^\circ C$	—	300	—	ns
—	Response time	$V_{RL} = 5V$, $R_L = 5.1k\Omega$ (Note 13)		$T_A = +25^\circ C$	—	1.3	—	μs
$I_{O(SINK)}$	Output sink current	$V_{IN-} = 1V$, $V_{IN+} = 0$, $V_O \leq 1.5V$		$T_A = +25^\circ C$	6	16	—	mA
V_{SAT}	Saturation voltage	$V_{IN-} = 1V$, $V_{IN+} = 0$, $I_{SINK} \leq 4mA$		$T_A = +25^\circ C$	—	100	400	mV
				Full range	—	—	700	
$I_{O(LEAK)}$	Output leakage current	$V_{IN-} = 0V$, $V_{IN+} = 1$, $V_O = 5V$		$T_A = +25^\circ C$	—	0.1	—	nA
		$V_{IN-} = 0V$, $V_{IN+} = 1$, $V_O = 30V$		Full range	—	—	1	μA
V_{ID}	Differential input voltage	All $V_{IN} \geq 0V$ (or V_- if used) (Note 14)		Full range	—	—	36	V

- Notes:
- Typical values represent the most likely parametric norm as determined at the time of characterization. Actual typical values may vary over time and will also depend on the application and configuration. The typical values are not tested and are not guaranteed on shipped production material.
 - All limits are guaranteed by testing or statistical analysis. Limits over the full temperature are guaranteed by design, but not tested in production.
 - $V_O \cong 1.4V$, $R_S = 0\Omega$ with V_{CC} from $5V$ to $30V$;
 - The direction of the input current is out of the IC due to the PNP input stage. This current is essentially constant, independent of the state of the output so no loading change exists on the input lines.
 - The input common-mode voltage of either input signal voltage should not be allowed to go negative by more than $0.3V$ (@ $+25^\circ C$). The upper end of the common-mode voltage range is $V_{CC}-1.5V$ (@ $+25^\circ C$), but either or both inputs can go to $+36V$ without damage, independent of the magnitude of V_{CC} .
 - The response time specified is for a $100mV$ step input with $5mV$ overdrive. For larger overdrive signals $300ns$ can be obtained, see typical performance characteristics.
 - Positive excursions of input voltage may exceed the power supply level. As long as other voltages remain within the common mode range, the comparator will provide a proper output stage. The low voltage state must not be less than $-0.3V$ (or $0.3V$ below the magnitude of the negative power supply, if used).

Electrical Characteristics (Notes 8 & 9) (@ $V_{CC}=5.0V$, $GND=0V$, $T_A = +25^\circ C$, unless otherwise specified.)

LM2903, LM2903A								
Parameter		Conditions		T_A	Min	Typ	Max	Unit
V_{IO}	Input Offset Voltage	$V_{IC} = V_{CMR} \text{ min,}$ $V_O = 1.4V,$ $V_{CC} = 5V \text{ to } =30V$ (Note 10)	Non-A Device	$T_A = +25^\circ C$	—	2	7	mV
				Full range	—	—	15	
			A-Suffix Device	$T_A = +25^\circ C$	—	1	2	
				Full range	—	—	4	
I_B	Input Bias Current	I_{IN+} or I_{IN-} with OUT in linear range, $V_{CM} = 0V$ (Note 11)		$T_A = +25^\circ C$	—	25	250	nA
				Full range	—	—	500	
I_{IO}	Input Offset Current	$I_{IN+} - I_{IN-}, V_{CM} = 0V$		$T_A = +25^\circ C$	—	5	50	nA
				Full range	—	—	200	
V_{CMR}	Input Common-Mode Voltage Range	$V_{CC} = 30V$ (Note 12)		$T_A = +25^\circ C$	0 to $V_{CC} - 1.5$	—	—	V
				Full range	0 to $V_{CC} - 2$	—	—	
I_{CC}	Supply Current	$R_L = \infty$ on both channels	$V_{CC} = 30V$	$T_A = +25^\circ C$	—	0.7	1.7	mA
				Full range	—	—	3.0	
			$V_{CC} = 5V$	$T_A = +25^\circ C$	—	0.6	1	
				Full range	—	—	2.0	
A_V	Voltage Gain	$V_{CC} = 15V, V_{OUT} = 1V \text{ to } 11V,$ $R_L \geq 15k\Omega,$		$T_A = +25^\circ C$	50	200	—	V/mV
—	Large Signal Response time	$V_{IN} = \text{TTL logic swing, } V_{REF} = 1.4V,$ $V_{RL} = 5V, R_L = 5.1k\Omega$		$T_A = +25^\circ C$	—	300	—	ns
—	Response time	$V_{RL} = 5V, R_L = 5.1k\Omega$ (Note 13)		$T_A = +25^\circ C$	—	1.3	—	μs
$I_{O(SINK)}$	Output sink current	$V_{IN-} = 1V, V_{IN+} = 0, V_O \leq 1.5V$		$T_A = +25^\circ C$	6	16	—	mA
V_{SAT}	Saturation voltage	$V_{IN-} = 1V, V_{IN+} = 0, I_{SINK} \leq 4mA$		$T_A = +25^\circ C$	—	200	400	mV
				Full range	—	—	700	
$I_{O(LEAK)}$	Output leakage current	$V_{IN-} = 0V, V_{IN+} = 1, V_O = 5V$		$T_A = +25^\circ C$	—	0.1	—	nA
		$V_{IN-} = 0V, V_{IN+} = 1, V_O = 30V$		Full range	—	—	1	μA
V_{ID}	Differential input voltage	All $V_{IN} \geq 0V$ (or V_- if used) (Note 14)		Full range	—	—	36	V

- Notes:
8. Typical values represent the most likely parametric norm as determined at the time of characterization. Actual typical values may vary over time and will also depend on the application and configuration. The typical values are not tested and are not guaranteed on shipped production material.
 9. All limits are guaranteed by testing or statistical analysis. Limits over the full temperature are guaranteed by design, but not tested in production.
 10. $V_O \cong 1.4V, R_S = 0\Omega$ with V_{CC} from 5V to 30V;
 11. The direction of the input current is out of the IC due to the PNP input stage. This current is essentially constant, independent of the state of the output so no loading change exists on the input lines.
 12. The input common-mode voltage of either input signal voltage should not be allowed to go negative by more than 0.3V (@ +25°C). The upper end of the common-mode voltage range is $V_{CC} - 1.5V$ (@ +25°C), but either or both inputs can go to +36V without damage, independent of the magnitude of V_{CC} .
 13. The response time specified is for a 100mV step input with 5mV overdrive. For larger overdrive signals 300ns can be obtained, see typical performance characteristics.
 14. Positive excursions of input voltage may exceed the power supply level. As long as other voltages remain within the common mode range, the comparator will provide a proper output stage. The low voltage state must not be less than -0.3V (or 0.3V below the magnitude of the negative power supply, if used).

Performance Characteristics

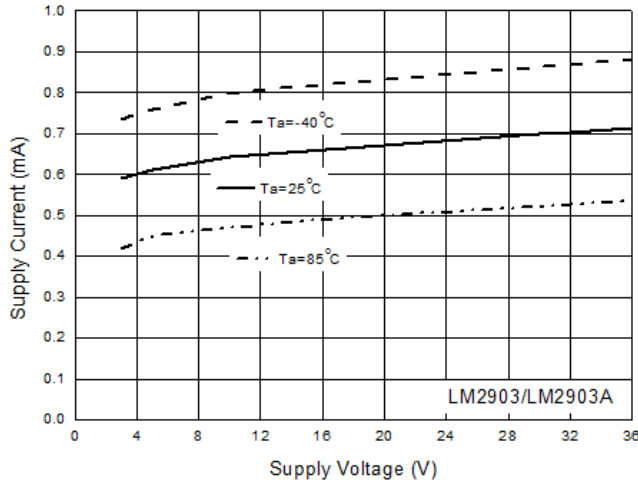

Supply Current vs. Supply Voltage

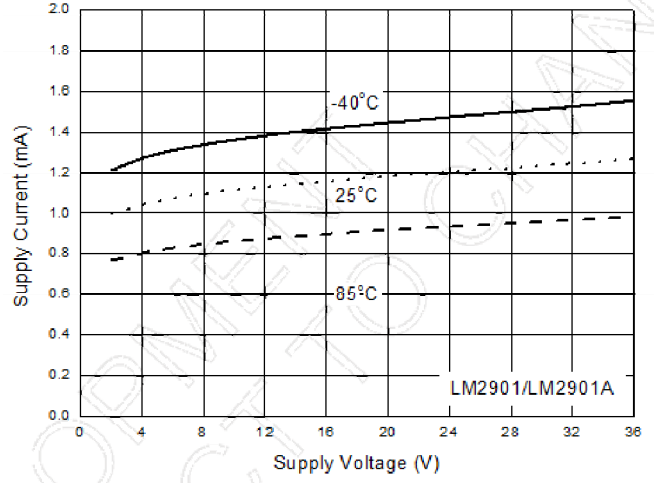

Supply Current vs. Supply Voltage

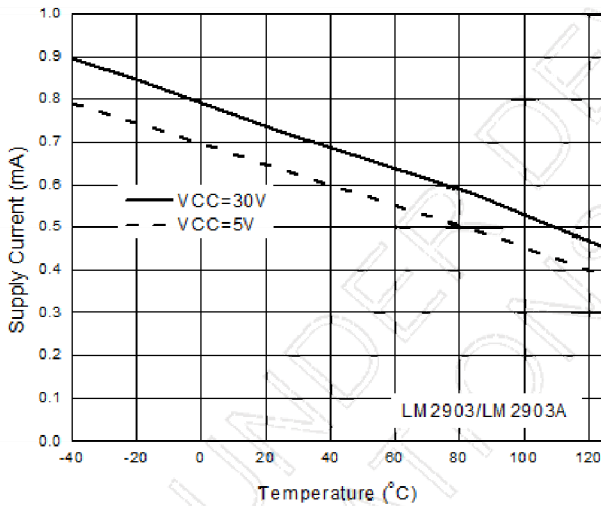

Supply Current vs. Temperature

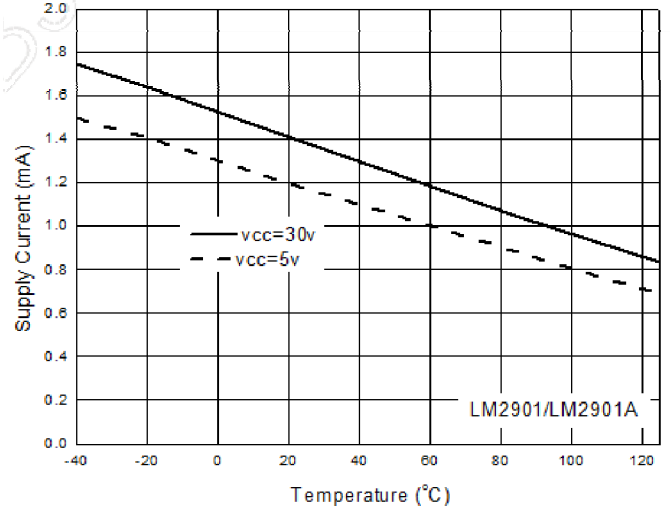

Supply Current vs. Temperature

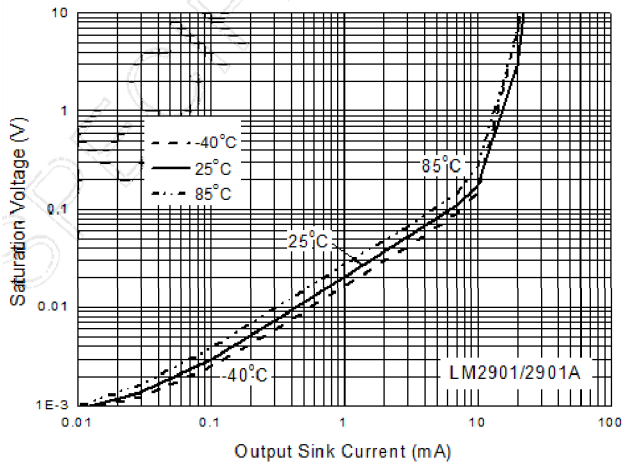

Output Saturation Voltage vs. Sink Current

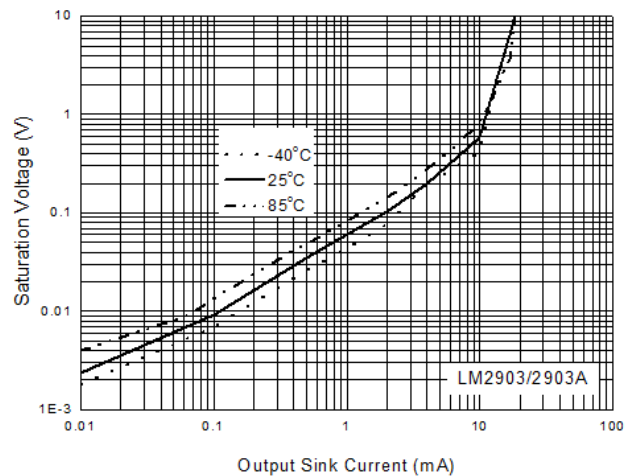

Output Saturation Voltage vs. Sink Current

Performance Characteristics (cont.)

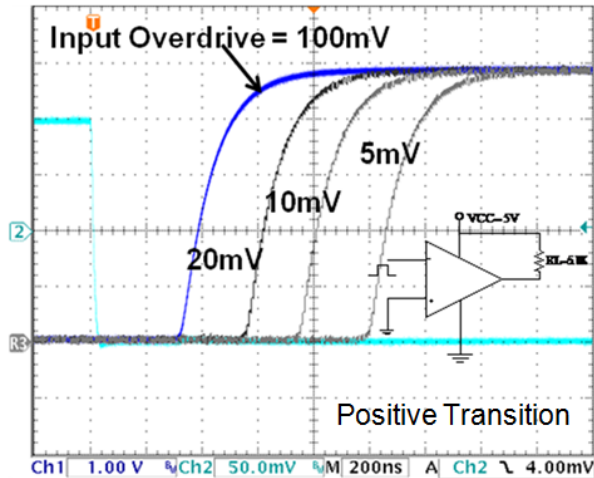

Response Time for Various Input Overdrive

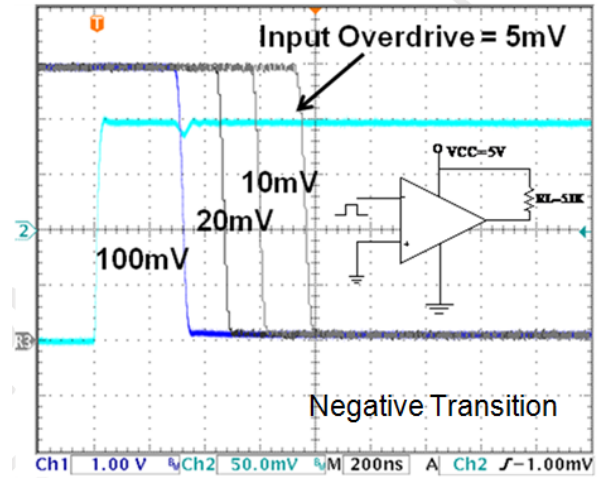

Response Time for Various Input Overdrive

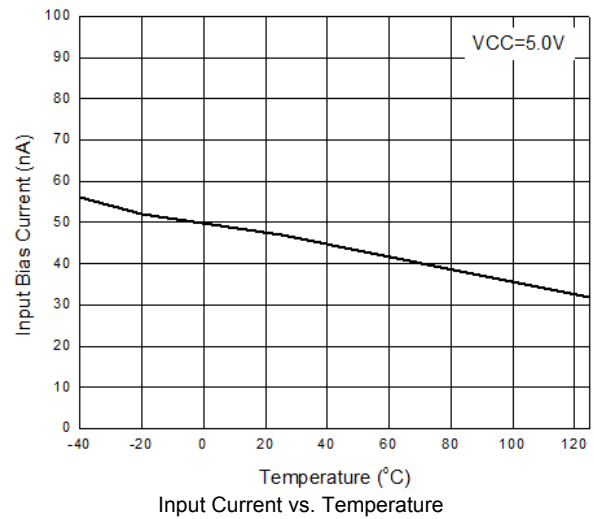
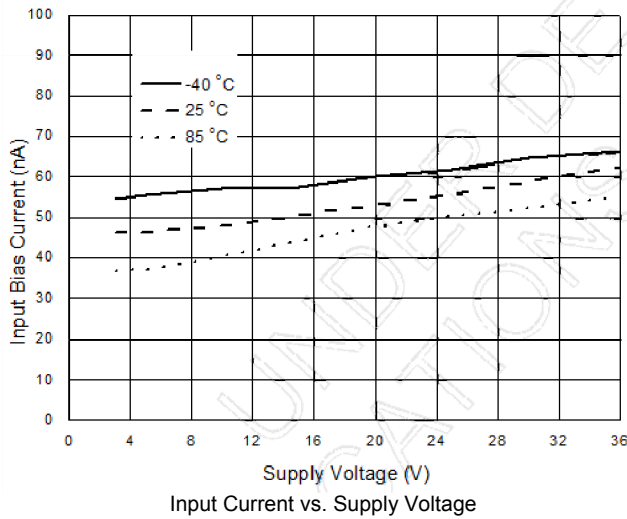

Application Information

General Information

The LM2901/2903 series comparators are high gain, wide bandwidth devices, like most comparators, can easily oscillate if the output lead is inadvertently allowed to capacitively couple to the inputs via stray capacitance. This shows up only during the output voltage transition intervals as the comparator change states. Standard PC board layout is helpful as it reduces stray input-output coupling. Reducing the input resistors to < 10k Ω reduces the feedback signal levels and finally, adding even a small amount (1.0 to 10 mV) of positive feedback (hysteresis) causes such a rapid transition that oscillations due to stray feedback are not possible. Simply socketing the IC and attaching resistors to the pins will cause input-output oscillations during the small transition intervals unless hysteresis is used. If the input signal is a pulse waveform, with relatively fast rise and fall times, hysteresis is not required. All input pins of any unused comparators should be tied to the negative supply.

The bias network of the LM2901/2903 series comparators establishes a quiescent current independent of the magnitude of the power supply voltage over the range of from 2.0 V_{DC} to 30 V_{DC} .

The differential input voltage may be larger than V_{CC} without damaging the device (Note16). Protection should be provided to prevent the input voltages from going negative more than -0.3 V_{DC} (@ 25°C). An input clamp diode can be used as shown in the applications section.

The output of the LM2901/2903 series comparators is the uncommitted collector of a grounded-emitter NPN output transistor. Many collectors can be tied together to provide an output OR'ing function. An output pull-up resistor can be connected to any available power supply voltage within the permitted supply voltage range and there is no restriction on this voltage due to the magnitude of the voltage applied to the V_{CC} terminal of LM2901/2903 series comparator package. The output can also be used as a simple SPST switch to ground (when a pull-up resistor is not used).

The amount of current the output device can sink is limited by the drive available (which is independent of V_{CC}) and the β of this device. When the maximum current limit is reached (approximately 16mA), the output transistor will come out of saturation and the output voltage will rise very rapidly. The output saturation voltage is limited by the approximately 60 Ω R_{SAT} of the output transistor. The low offset voltage of the output transistor (1.0 mV) allows the output to clamp essentially to ground level for small load currents.

Typical Application Circuit ($V_{CC} = 5.0V_{DC}$)

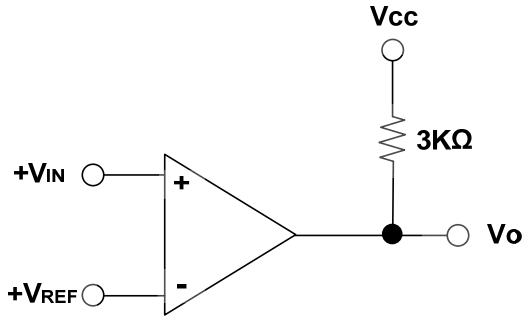

Basic Comparator

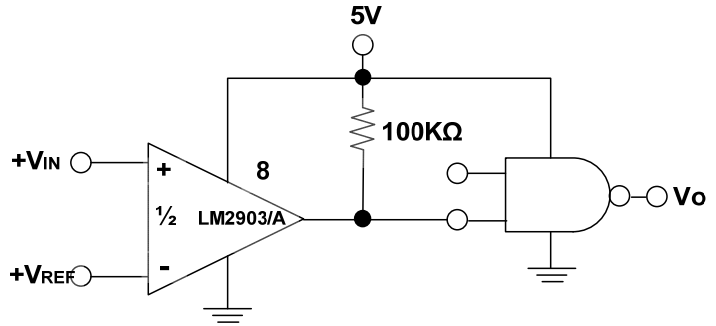

Driving CMOS

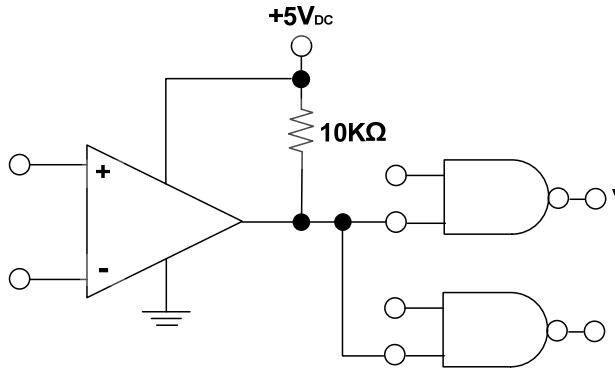

Driving TTL

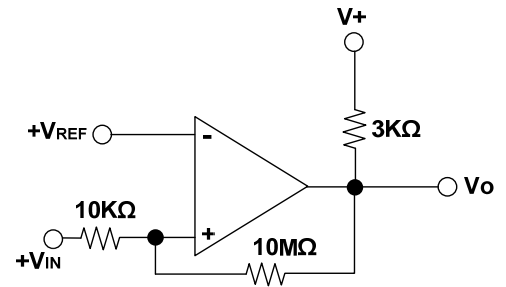

Non-Inverting Comparator with Hysteresis

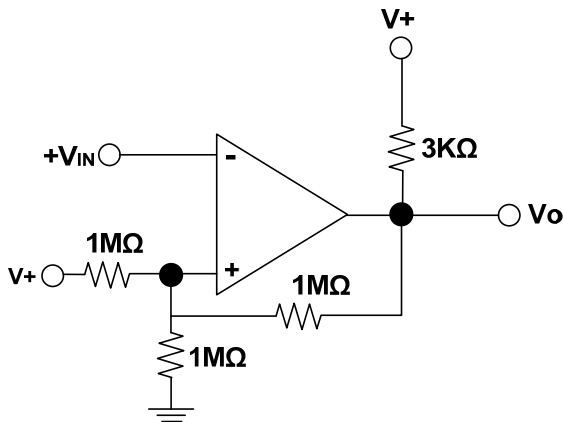

Inverting Comparator with Hysteresis

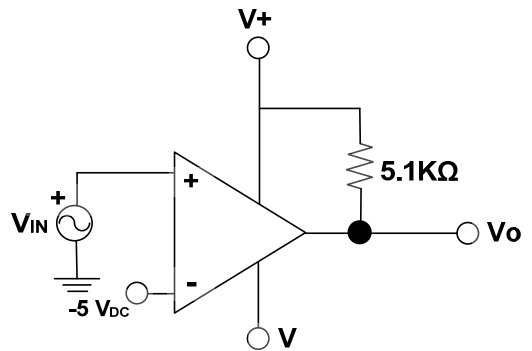

Comparator with a Negative Reference

Typical Application Circuit ($V_{CC} = 5.0V_{DC}$) (cont.)

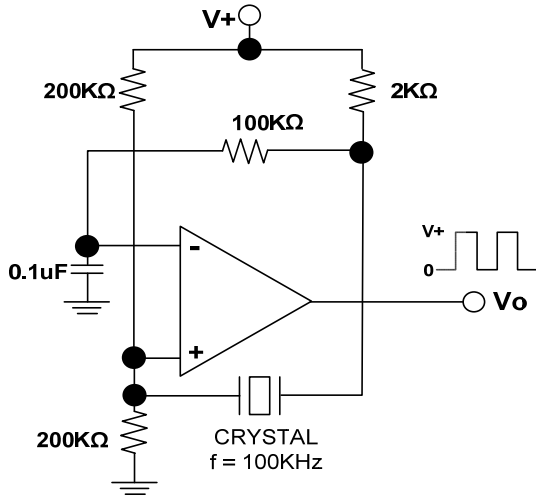

Crystal Controlled Oscillator

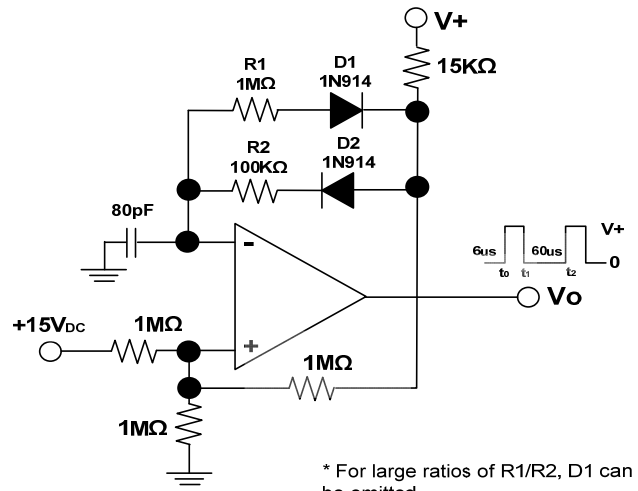

Pulse Generator

* For large ratios of R1/R2, D1 can be omitted.

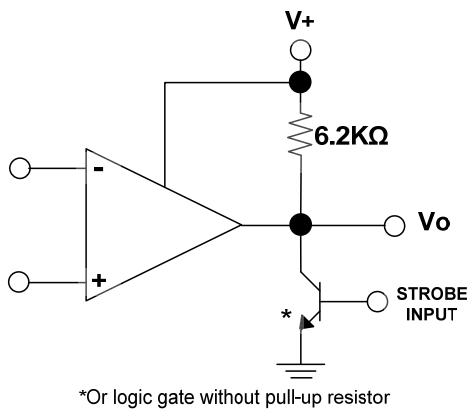

*Or logic gate without pull-up resistor

Output Strobing

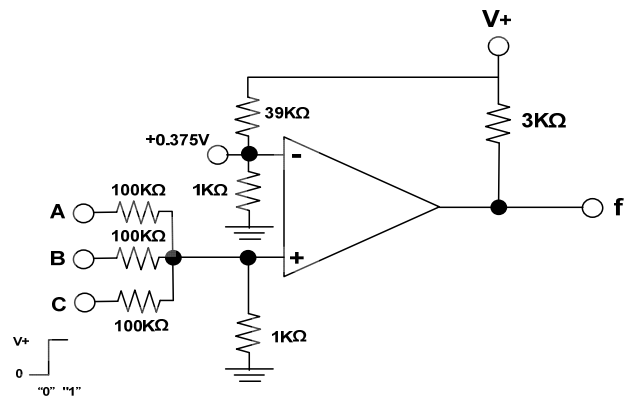

AND Gate

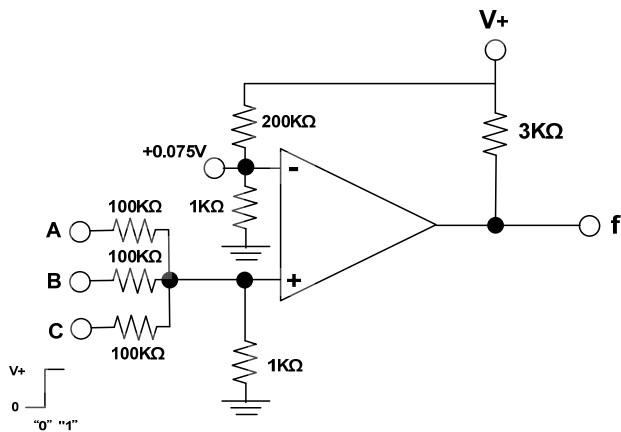

OR Gate

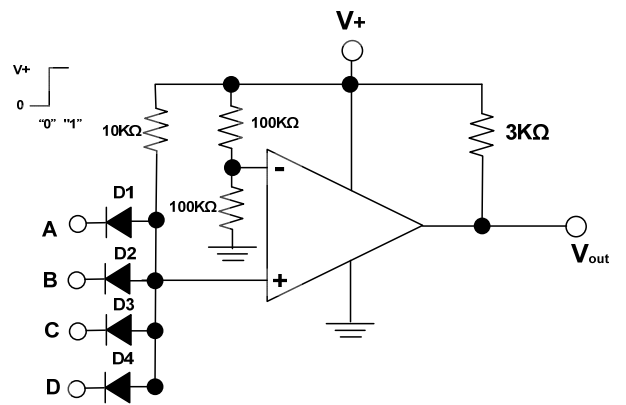

Large Fan-in AND Gate

Typical Application Circuit ($V_{CC} = 5.0V_{DC}$) (cont.)

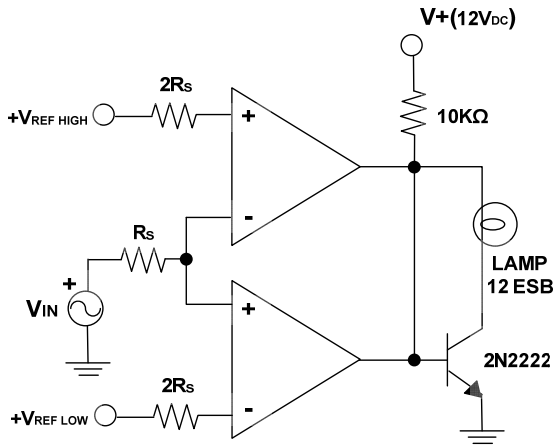

Limit Comparator

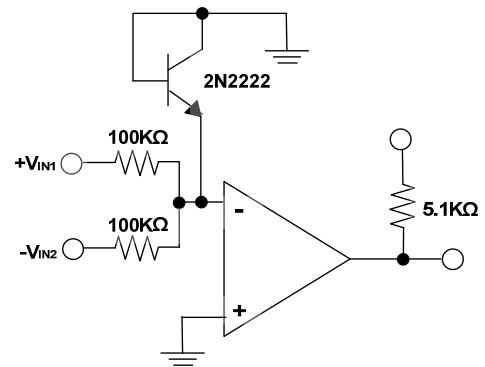

Comparing Input Voltage of Opposite Polarity

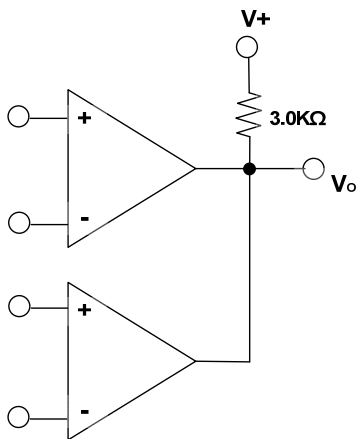

ORing the Outputs

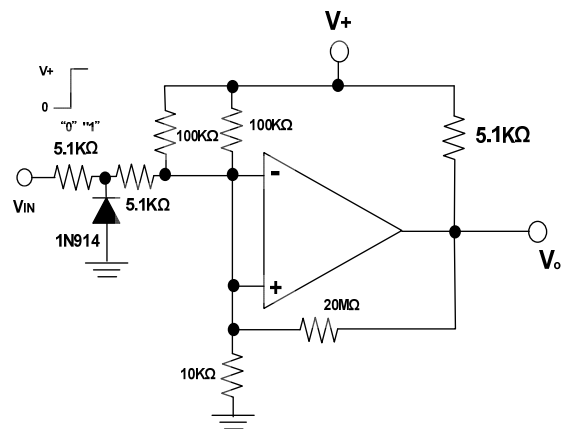

Zero Crossing Detector (Single Power Supply)

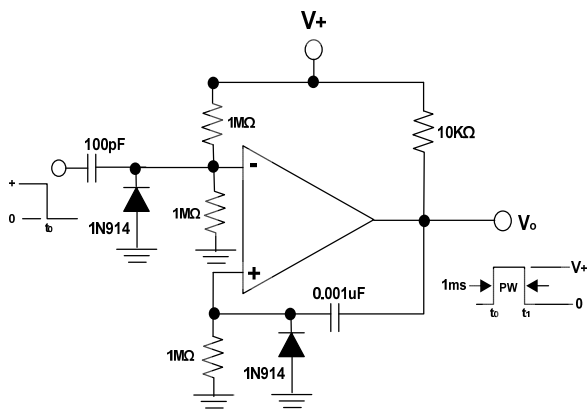

One-Shot Multivibrator

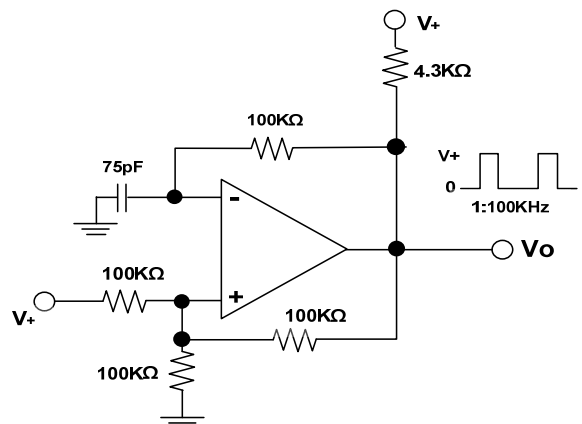

Squarewave Oscillator

Ordering Information

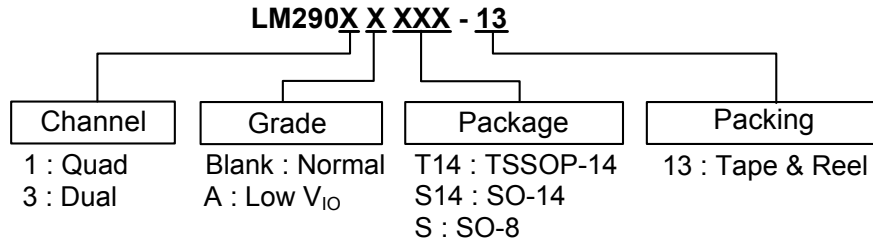

Part Number	Package Code	Packaging	13" Tape and Reel		Remark
			Quantity	Part Number Suffix	
LM2901T14-13	T14	TSSOP-14	2500/Tape & Reel	-13	RTP'd
LM2901AT14-13	T14	TSSOP-14	2500/Tape & Reel	-13	RTP'd
LM2901S14-13	S14	SO-14	2500/Tape & Reel	-13	Under qualification
LM2901AS14-13	S14	SO-14	2500/Tape & Reel	-13	Under qualification
LM2903S-13	S	SO-8	2500/Tape & Reel	-13	RTP'd
LM2903AS-13	S	SO-8	2500/Tape & Reel	-13	RTP'd

Note: 15. For packaging details, go to our website at <http://www.diodes.com/products/packages.html>

Marking Information

(1) TSSOP-14 and SO-14

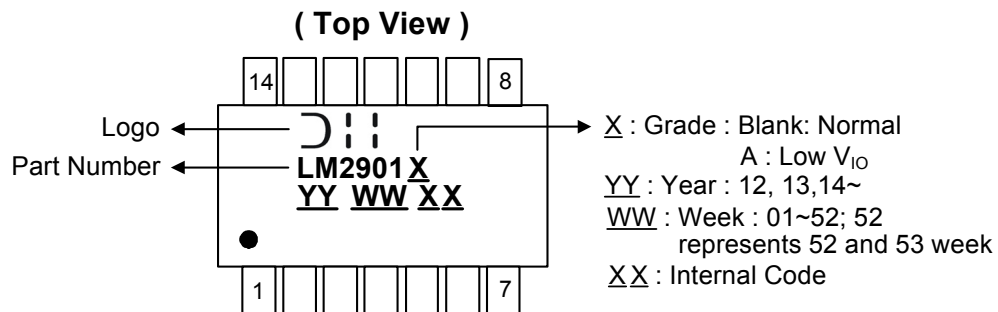

(2) SO-8

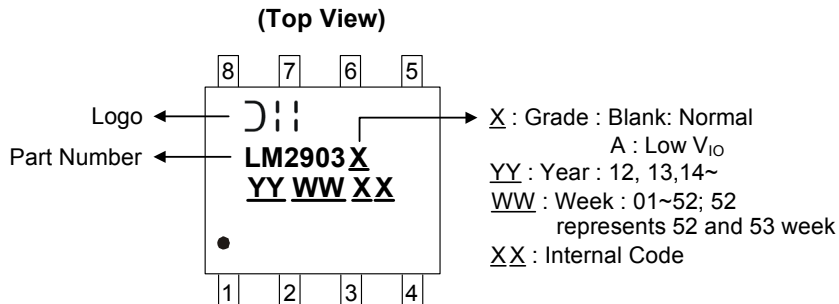

Package Outline Dimensions (All dimensions in mm.)

Please see AP02002 at <http://www.diodes.com/datasheets/ap02002.pdf> for latest version.

(1) Package Type: SO-14

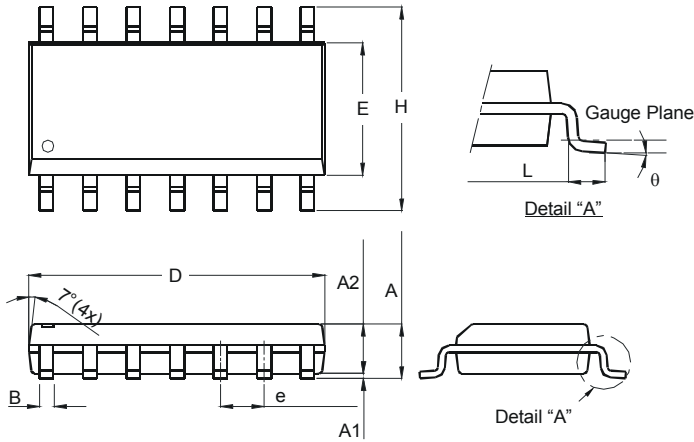

SO-14		
Dim	Min	Max
A	1.47	1.73
A1	0.10	0.25
A2	1.45 Typ	
B	0.33	0.51
D	8.53	8.74
E	3.80	3.99
e	1.27 Typ	
H	5.80	6.20
L	0.38	1.27
θ	0°	8°
All Dimensions in mm		

(2) Package Type: SO-8

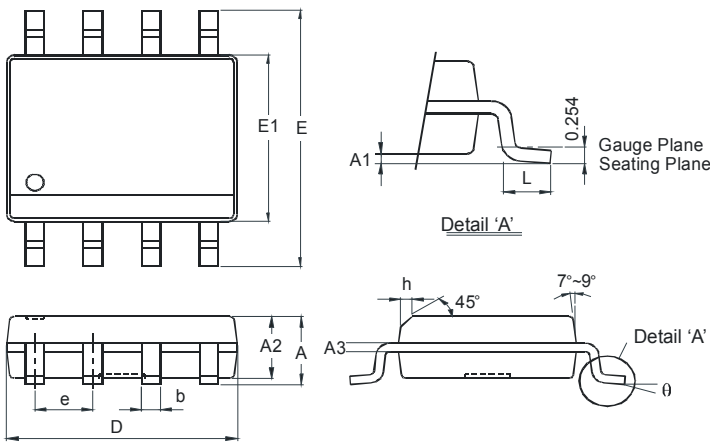

SO-8		
Dim	Min	Max
A	-	1.75
A1	0.10	0.20
A2	1.30	1.50
A3	0.15	0.25
b	0.3	0.5
D	4.85	4.95
E	5.90	6.10
E1	3.85	3.95
e	1.27 Typ	
h	-	0.35
L	0.62	0.82
θ	0°	8°
All Dimensions in mm		

(3) Package Type: TSSOP-14

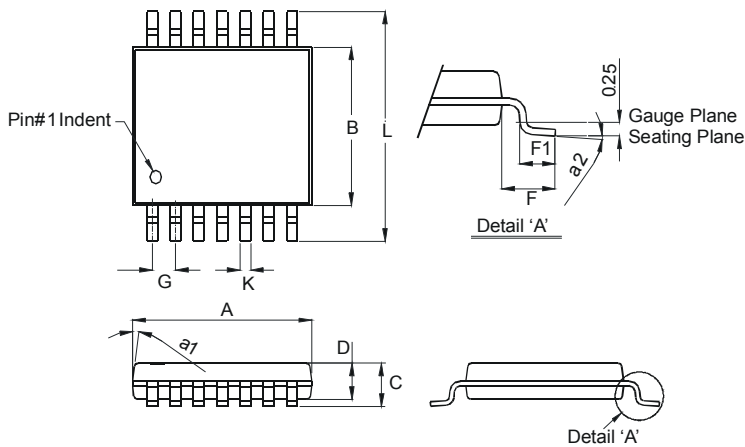

TSSOP-14		
Dim	Min	Max
a1	7° (4X)	
a2	0°	8°
A	4.9	5.10
B	4.30	4.50
C	1.2	
D	0.8	1.05
F	1.00 Typ	
F1	0.45	0.75
G	0.65 Typ	
K	0.19	0.30
L	6.40 Typ	
All Dimensions in mm		

Suggested Pad Layout

Please see AP02001 at <http://www.diodes.com/datasheets/ap02001.pdf> for the latest version.

(1) Package Type: SO-14

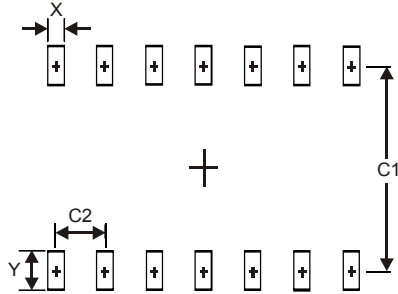

Dimensions	Value (in mm)
X	0.60
Y	1.50
C1	5.4
C2	1.27

(2) Package Type: SO-8

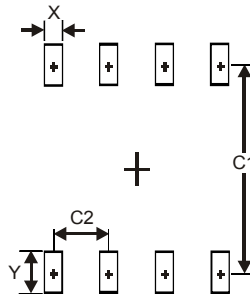

Dimensions	Value (in mm)
X	0.60
Y	1.55
C1	5.4
C2	1.27

(3) Package Type: TSSOP-14

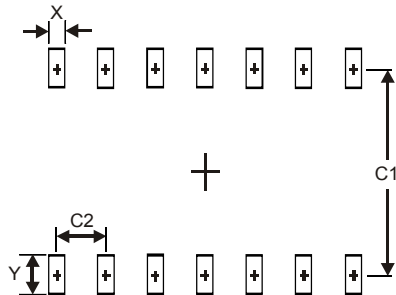

Dimensions	Value (in mm)
X	0.45
Y	1.45
C1	5.9
C2	0.65

IMPORTANT NOTICE

DIODES INCORPORATED MAKES NO WARRANTY OF ANY KIND, EXPRESS OR IMPLIED, WITH REGARDS TO THIS DOCUMENT, INCLUDING, BUT NOT LIMITED TO, THE IMPLIED WARRANTIES OF MERCHANTABILITY AND FITNESS FOR A PARTICULAR PURPOSE (AND THEIR EQUIVALENTS UNDER THE LAWS OF ANY JURISDICTION).

Diodes Incorporated and its subsidiaries reserve the right to make modifications, enhancements, improvements, corrections or other changes without further notice to this document and any product described herein. Diodes Incorporated does not assume any liability arising out of the application or use of this document or any product described herein; neither does Diodes Incorporated convey any license under its patent or trademark rights, nor the rights of others. Any Customer or user of this document or products described herein in such applications shall assume all risks of such use and will agree to hold Diodes Incorporated and all the companies whose products are represented on Diodes Incorporated website, harmless against all damages.

Diodes Incorporated does not warrant or accept any liability whatsoever in respect of any products purchased through unauthorized sales channel. Should Customers purchase or use Diodes Incorporated products for any unintended or unauthorized application, Customers shall indemnify and hold Diodes Incorporated and its representatives harmless against all claims, damages, expenses, and attorney fees arising out of, directly or indirectly, any claim of personal injury or death associated with such unintended or unauthorized application.

Products described herein may be covered by one or more United States, international or foreign patents pending. Product names and markings noted herein may also be covered by one or more United States, international or foreign trademarks.

This document is written in English but may be translated into multiple languages for reference. Only the English version of this document is the final and determinative format released by Diodes Incorporated.

LIFE SUPPORT

Diodes Incorporated products are specifically not authorized for use as critical components in life support devices or systems without the express written approval of the Chief Executive Officer of Diodes Incorporated. As used herein:

A. Life support devices or systems are devices or systems which:

1. are intended to implant into the body, or
2. support or sustain life and whose failure to perform when properly used in accordance with instructions for use provided in the labeling can be reasonably expected to result in significant injury to the user.

B. A critical component is any component in a life support device or system whose failure to perform can be reasonably expected to cause the failure of the life support device or to affect its safety or effectiveness.

Customers represent that they have all necessary expertise in the safety and regulatory ramifications of their life support devices or systems, and acknowledge and agree that they are solely responsible for all legal, regulatory and safety-related requirements concerning their products and any use of Diodes Incorporated products in such safety-critical, life support devices or systems, notwithstanding any devices- or systems-related information or support that may be provided by Diodes Incorporated. Further, Customers must fully indemnify Diodes Incorporated and its representatives against any damages arising out of the use of Diodes Incorporated products in such safety-critical, life support devices or systems.

Copyright © 2014, Diodes Incorporated

www.diodes.com