

**Part Number**

[MWS-1-19](#)

**Description**

Micro Wire Saddle, Natural



NYLON 6/6 (RMS-01) COLOR: NATURAL. PART NO.	FLAME RET. (RMS-19) COLOR: NATURAL. PART NO.	DIM. "A" REF.	DIM. "B" REF.	HOLE DIA.	PANEL THICKNESS
MWS-1-01	MWS-1-19	.23 (5.8)	.12 (3.0)	.070±.002 (1.75±0.05)	.062 (1.57)
MWS1-1-01	MWS1-1-19				.093 (2.36)
-----	MWS-2-19	.44 (11.2)	.33 (8.5)		.063 (1.60)
-----	MWS-3-19			.087 (2.20)	

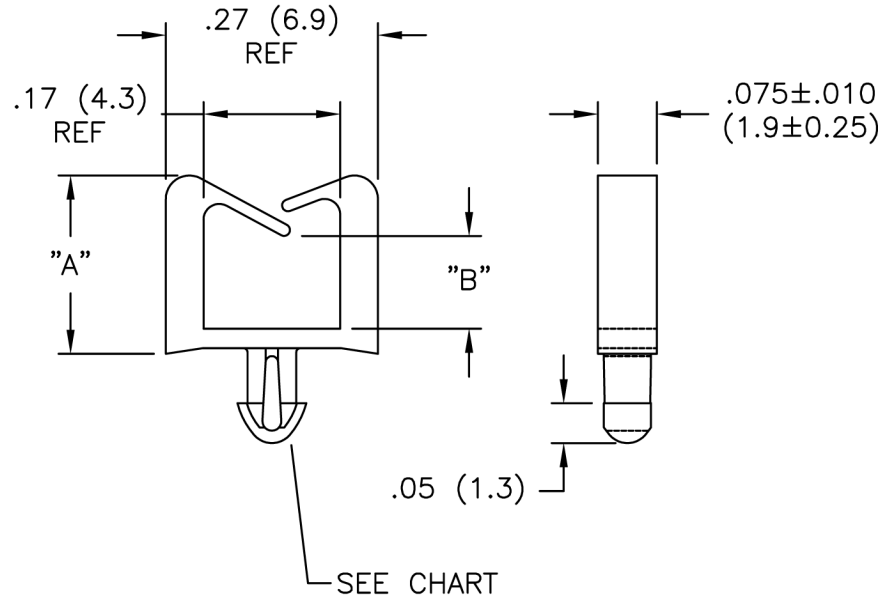
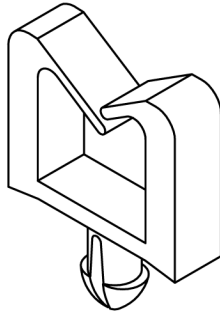

F SEE ECN #887 FOR CHANGES SM 12.13.04			TITLE: MICRO WIRE SADDLE				DWG IN IN (MM)		FINAL		
E UPDATED PRINT AND CHANGED FILE NO. SM 05.29.01			FILE # MWS		DWN: JL	DT: 07/26/00		PART #		PRINT	
D REVISED TABLE J.L 07.26.00			MAT'L: SEE TABLE		CHKD:		ENG:		TYPE		
C MAT'L RMS-19 ADDED J.L 12.10.97			RE: RICHCO, INC.		RICHCO INC.		SEE TABLE		CA		
B ADDED P/N MWS1 AND PUT IN CHART JB 12.22.95											
A CONVERTED TO ACAD PB 10.21.94											
REV DESCRIPTION ENGR DATE											

TOLERANCES  
UNLESS NOTED  
.XX=±.01  
.XXX=±.005  
FRAC=±1/64  
ANG=±1°