

SMD Tuning Fork

Model: FSXLF

RoHS Compliant / PB Free

Page 1 of 2

FEATURES

- Extremely Small Size
- Low Cost
- 1.4mm Height Max
- Tape and Reel (3,000 pcs. STD)

• PART NUMBER [Learn More](#) - Internet Required

Part Number	Model Number	Frequency Stability	Operating Temperature	Frequency
501LF-Frequency-xxxxx	FSXLF	-0.04PPM/($\Delta^{\circ}\text{C}$) ²	-40 ~ +85 $^{\circ}\text{C}$	32.768 kHz

• STANDARD SPECIFICATIONS

PARAMETERS	MAX (unless otherwise noted)
Frequency Range	32.768 kHz
Frequency Tolerance @ 25 $^{\circ}\text{C}$	± 20 PPM
Frequency Stability, ref @ 25 $^{\circ}\text{C}$	-0.04PPM/($\Delta^{\circ}\text{C}$) ²
Temperature Range	
Turnover (T _O)	+20 $^{\circ}\text{C}$ ~ +30 $^{\circ}\text{C}$
Operating (T _{OPR})	-40 $^{\circ}\text{C}$ ~ +85 $^{\circ}\text{C}$
Storage (T _{STG})	-55 $^{\circ}\text{C}$ ~ +125 $^{\circ}\text{C}$
Equivalent Series Resistance	65 k Ω
Load Capacitance (CL)	7 pF, 12.5pF Typ
Insulation Resistance @ 100VDC	500 M Ω Min
Drive Level	1.0 μW
Aging	± 3 PPM
Termination Finish	Matte Sn

All specifications subject to change without notice.

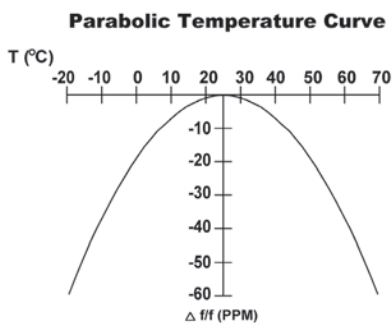
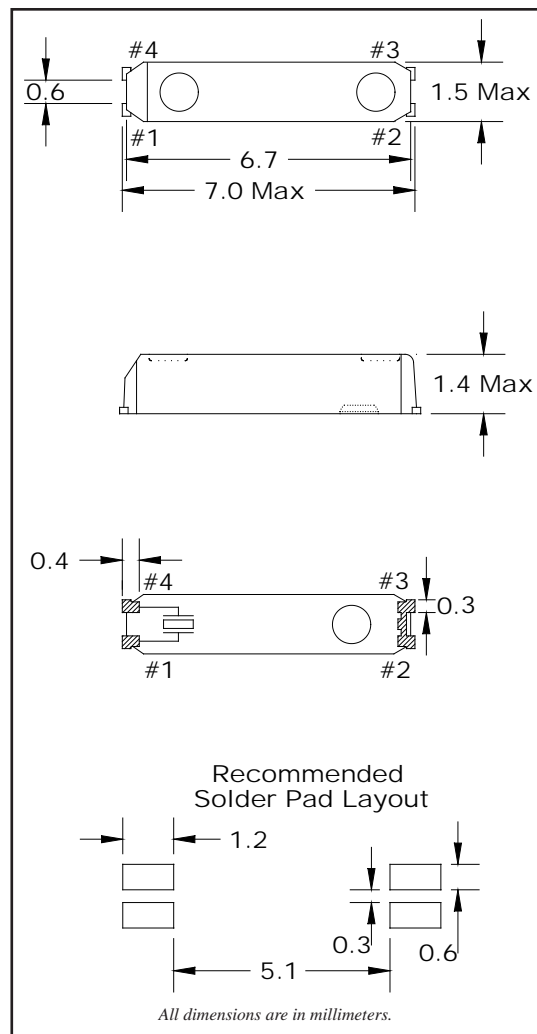

To determine frequency stability, use parabolic curvature (K).
For example: What is stability at 45 $^{\circ}\text{C}$?

- 1) Change in T ($^{\circ}\text{C}$) = 45-25 = 20 $^{\circ}\text{C}$
- 2) Change in frequency = -0.04 PPM * ($\Delta^{\circ}\text{C}$)²
= -0.04 PPM * (20)²
= -16.0 PPM

SMD Tuning Fork



Model: FSXLF

RoHS Compliant / PB Free

Page 2 of 2

• TAPE SPECIFICATIONS (millimeters)							
MODEL	A	B	C	D	E	F	STD Reel QTY
FSXLF	∅1.5	4.0	8.0	7.5	16.0	1.6	3,000

• REEL SPECIFICATIONS (millimeters)							
MODEL	G	H	I	J	K	L	M
FSXLF	2.0	∅13	∅21	∅50	∅330	16.4	2.0

