

ASSP

Dual Serial Input PLL Frequency Synthesizer

MB15F72UL

■ DESCRIPTION

The Fujitsu MB15F72UL is a serial input Phase Locked Loop (PLL) frequency synthesizer with a 1300 MHz and a 350 MHz prescalers. A 64/65 or a 128/129 for the 1300 MHz prescaler, and a 8/9 or a 16/17 for the 350 MHz prescaler can be selected for the prescaler that enables pulse swallow operation.

The BiCMOS process is used, as a result a supply current is typically 2.5 mA at 2.7 V. The supply voltage range is from 2.4 V to 3.6 V. A refined charge pump supplies well-balanced output current with 1.5 mA and 6 mA selectable by serial data. The data format is the same as the previous one MB15F02SL, MB12F72SP. Fast locking is achieved for adopting the new circuit.

The new package (BCC20) decreases a mount area of MB15F72UL more than 30% comparing with the former BCC16 (for dual PLL).

MB15F72UL is ideally suited for wireless mobile communications, such as CDMA.

■ FEATURES

- High frequency operation : RF synthesizer : 1300 MHz Max.
: IF synthesizer : 350 MHz Max.
- Low power supply voltage : $V_{CC} = 2.4$ to 3.6 V
- Ultra low power supply current : $I_{CC} = 2.5$ mA Typ.
($V_{CC} = V_p = 2.7$ V, $SW_{IF} = SW_{RF} = 0$, $T_a = +25$ °C, in IF, RF locking state)

(Continued)

■ PACKAGES

20-pin plastic TSSOP

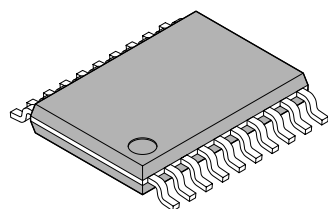

(FPT-20P-M06)

20-pad plastic BCC

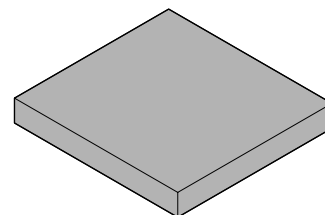

(LCC-20P-M05)

MB15F72UL

(Continued)

- Direct power saving function : Power supply current in power saving mode
Typ. 0.1 μ A ($V_{CC} = V_p = 2.7$ V, $T_a = +25$ °C)
Max. 10 μ A ($V_{CC} = V_p = 2.7$ V)
- Software selectable charge pump current : 1.5 mA/6.0 mA Typ.
- Dual modulus prescaler : 1300 MHz prescaler (64/65 or 128/129) /350 MHz prescaler (8/9 or 16/17)
- 23 bit shift resister
- Serial input 14-bit programmable reference divider : $R = 3$ to 16,383
- Serial input programmable divider consisting of :
 - Binary 7-bit swallow counter : 0 to 127
 - Binary 11-bit programmable counter : 3 to 2,047
- On-chip phase control for phase comparator
- On-chip phase comparator for fast lock and low noise
- Built-in digital locking detector circuit to detect PLL locking and unlocking.
- Operating temperature : $T_a = -40$ °C to $+85$ °C
- Serial data format compatible with MB15F02SL
- Small package BCC20 (3.4 mm \times 3.6 mm \times 0.6 mm)

PIN ASSIGNMENTS

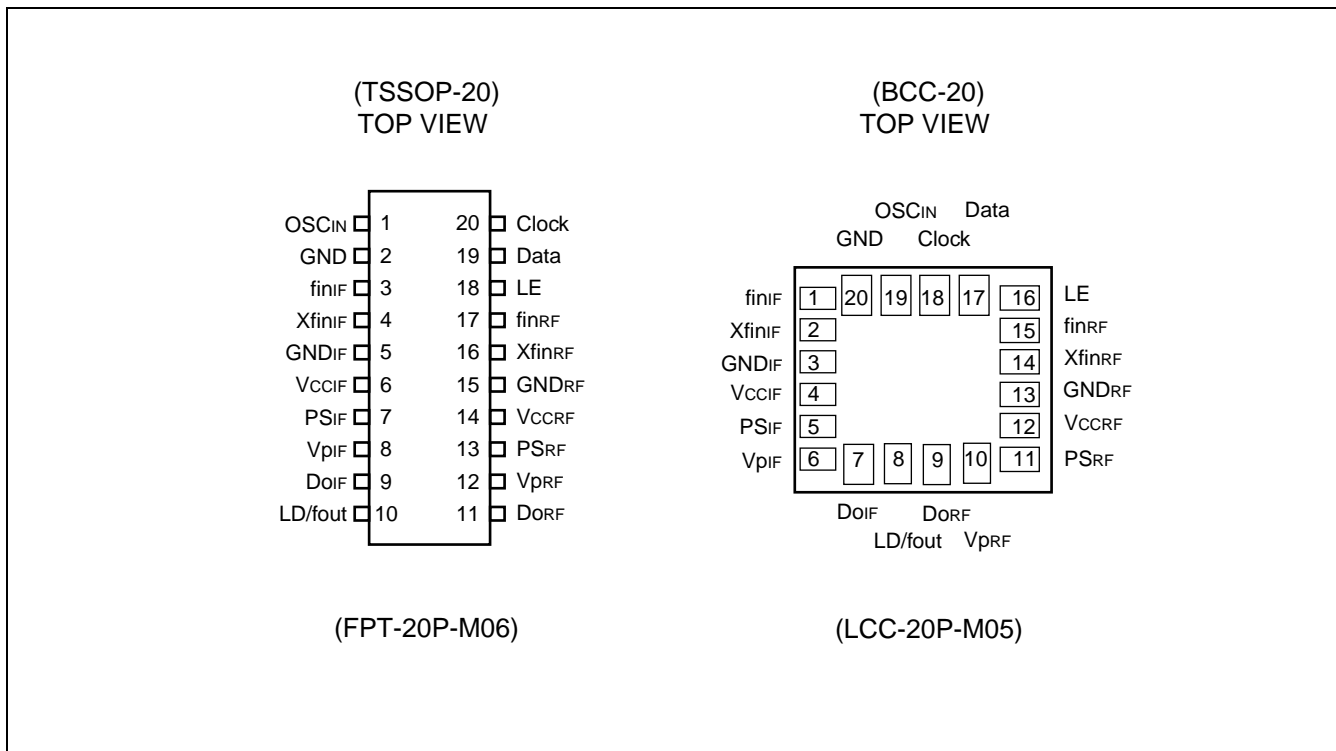

■ PIN DESCRIPTION

Pin no.		Pin name	I/O	Descriptions
TSSOP	BCC			
1	19	OSC _{IN}	I	The programmable reference divider input. TCXO should be connected with an AC coupling capacitor.
2	20	GND	—	Ground for OSC input buffer and the shift register circuit.
3	1	fin _{IF}	I	Prescaler input pin for the IF-PLL. Connection to an external VCO should be via AC coupling.
4	2	Xfin _{IF}	I	Prescaler complimentary input pin for the IF-PLL section. This pin should be grounded via a capacitor.
5	3	GND _{IF}	—	Ground for the IF-PLL section.
6	4	V _{CCIF}	—	Power supply voltage input pin for the IF-PLL section (except for the charge pump circuit), the OSC input buffer and the shift register circuit.
7	5	PS _{IF}	I	Power saving mode control for the IF-PLL section. This pin must be set at "L" when the power supply is started up. (Open is prohibited.) PS _{IF} = "H"; Normal mode / PS _{IF} = "L"; Power saving mode
8	6	V _{pIF}	—	Power supply voltage input pin for the IF-PLL charge pump.
9	7	DO _{IF}	O	Charge pump output pin for the IF-PLL section.
10	8	LD/fout	O	Lock detect signal output (LD) /phase comparator monitoring output (fout) pins. The output signal is selected by LDS bit in the serial data. LDS bit = "H"; outputs fout signal / LDS bit = "L"; outputs LD signal
11	9	DO _{RF}	O	Charge pump output pin for the RF-PLL section.
12	10	V _{pRF}	—	Power supply voltage input pin for the RF-PLL charge pump.
13	11	PS _{RF}	I	Power saving mode control pin for the RF-PLL section. This pin must be set at "L" when the power supply is started up. (Open is prohibited.) PS _{RF} = "H"; Normal mode / PS _{RF} = "L"; Power saving mode
14	12	V _{CCRF}	—	Power supply voltage input pin for the RF-PLL section (except for the charge pump circuit)
15	13	GND _{RF}	—	Ground for the RF-PLL section
16	14	Xfin _{RF}	I	Prescaler complimentary input pin for the RF-PLL section. This pin should be grounded via a capacitor.
17	15	fin _{RF}	I	Prescaler input pin for the RF-PLL. Connection to an external VCO should be via AC coupling.
18	16	LE	I	Load enable signal input pin (with the schmitt trigger circuit) When LE is set "H", data in the shift register is transferred to the corresponding latch according to the control bit in the serial data.
19	17	Data	I	Serial data input pin (with the schmitt trigger circuit) Data is transferred to the corresponding latch (IF-ref. counter, IF-prog. counter, RF-ref. counter, RF-prog. counter) according to the control bit in the serial data.
20	18	Clock	I	Clock input pin for the 23-bit shift register (with the schmitt trigger circuit) One bit of data is shifted into the shift register on a rising edge of the clock.

MB15F72UL

■ BLOCK DIAGRAM

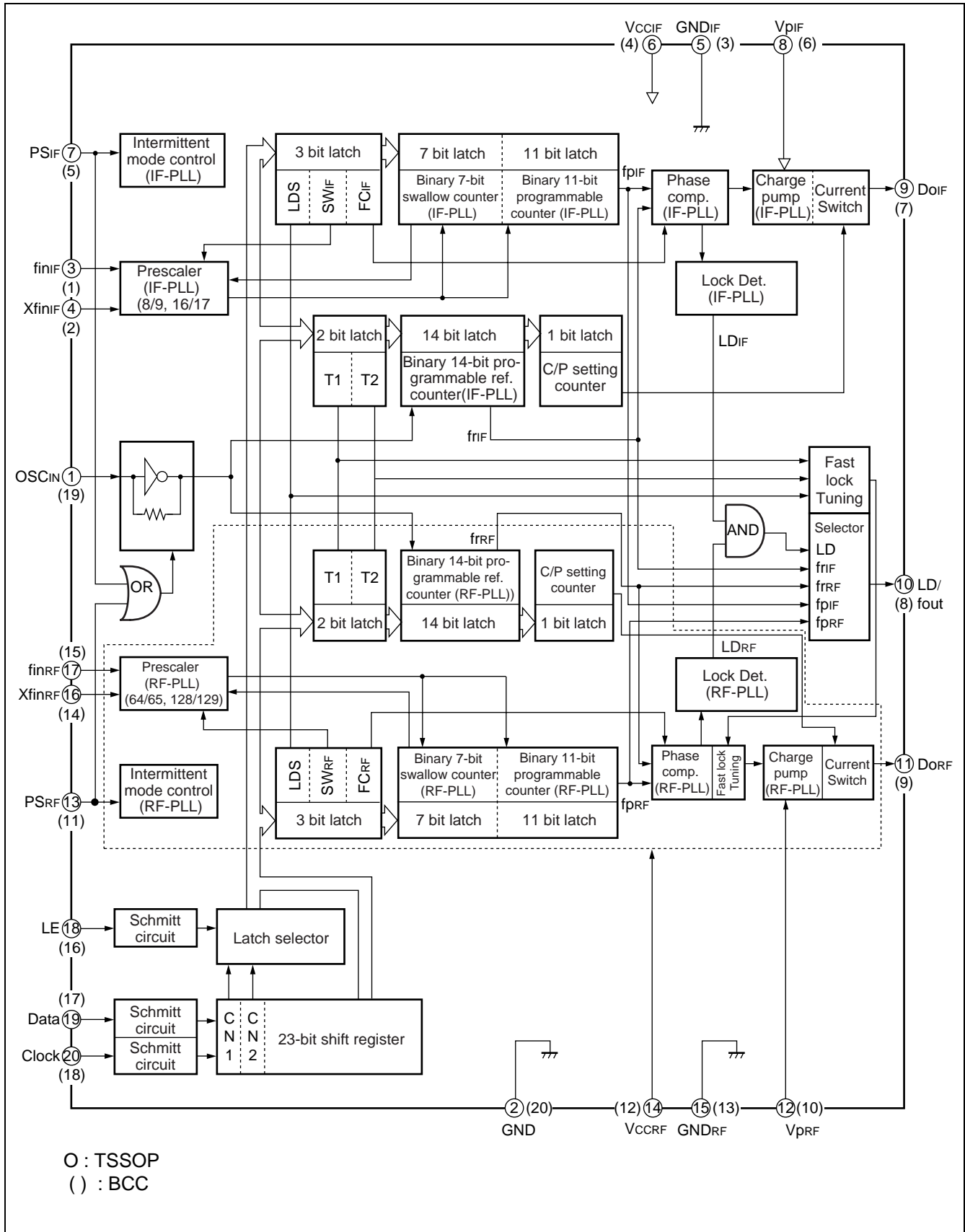

■ ABSOLUTE MAXIMUM RATINGS

Parameter	Symbol	Rating		Unit	
		Min.	Max.		
Power supply voltage	V _{CC}	-0.5	4.0	V	
	V _p	V _{CC}	4.0	V	
Input voltage	V _I	-0.5	V _{CC} + 0.5	V	
Output voltage	LD/fout	V _O	GND	V _{CC}	V
	DO _{IF} , DORF	V _{DO}	GND	V _p	V
Storage temperature	T _{stg}	-55	+125	°C	

WARNING: Semiconductor devices can be permanently damaged by application of stress (voltage, current, temperature, etc.) in excess of absolute maximum ratings. Do not exceed these ratings.

■ RECOMMENDED OPERATING CONDITIONS

Parameter	Symbol	Value			Unit	Remarks
		Min.	Typ.	Max.		
Power supply voltage	V _{CC}	2.4	2.7	3.6	V	V _{CCRF} = V _{CCIF}
	V _p	V _{CC}	2.7	3.6	V	
Input voltage	V _I	GND	—	V _{CC}	V	
Operating temperature	T _a	-40	—	+85	°C	

Note : • V_{CCRF}, V_{pRF}, V_{CCIF} and V_{pIF} must supply equal voltage.

Even if either RF-PLL or IF-PLL is not used, power must be supplied to V_{CCRF}, V_{pRF}, V_{CCIF} and V_{pIF} to keep them equal.

It is recommended that the non-use PLL is controlled by power saving function.

- Although this device contains an anti-static element to prevent electrostatic breakdown and the circuitry has been improved in electrostatic protection, observe the following precautions when handling the device.
 - When storing and transporting the device, put it in a conductive case.
 - Before handling the device, confirm the (jigs and) tools to be used have been uncharged (grounded) as well as yourself. Use a conductive sheet on working bench.
 - Before fitting the device into or removing it from the socket, turn the power supply off.
 - When handling (such as transporting) the device mounted board, protect the leads with a conductive sheet.

WARNING: The recommended operating conditions are required in order to ensure the normal operation of the semiconductor device. All of the device's electrical characteristics are warranted when the device is operated within these ranges.

Always use semiconductor devices within their recommended operating condition ranges. Operation outside these ranges may adversely affect reliability and could result in device failure.

No warranty is made with respect to uses, operating conditions, or combinations not represented on the data sheet. Users considering application outside the listed conditions are advised to contact their FUJITSU representatives beforehand.

MB15F72UL

■ ELECTRICAL CHARACTERISTICS

($V_{CC} = 2.4\text{ V to }3.6\text{ V}$, $T_a = -40\text{ }^\circ\text{C to }+85\text{ }^\circ\text{C}$)

Parameter	Sym- bol	Condition	Value			Unit	
			Min.	Typ.	Max.		
Power supply current	I_{CCIF}^{*1}	$fin_{IF} = 270\text{ MHz}$ $V_{CCIF} = V_{pIF} = 2.7\text{ V}$	0.6	1.0	1.7	mA	
	I_{CCRF}^{*1}	$fin_{RF} = 910\text{ MHz}$ $V_{CCRF} = V_{pRF} = 2.7\text{ V}$	1.0	1.5	2.5	mA	
Power saving current	I_{PSIF}	$PS_{IF} = PS_{RF} = \text{"L"}$	—	0.1^{*2}	10	μA	
	I_{PSRF}	$PS_{IF} = PS_{RF} = \text{"L"}$	—	0.1^{*2}	10	μA	
Operating frequency	fin_{IF}^{*3}	fin_{IF}	IF PLL	50	—	350	MHz
	fin_{RF}^{*3}	fin_{RF}	RF PLL	100	—	1300	MHz
	OSC_{IN}	f_{OSC}	—	3	—	40	MHz
Input sensitivity	fin_{IF}	$P_{fin_{IF}}$	IF PLL, $50\ \Omega$ system	-15	—	+2	dBm
	fin_{RF}	$P_{fin_{RF}}$	RF PLL, $50\ \Omega$ system	-15	—	+2	dBm
	OSC_{IN}	V_{OSC}	—	0.5	—	V_{CC}	V_{P-P}
"H" level input voltage	Data, LE, Clock	V_{IH}	Schmitt trigger input	$0.7 V_{CC} + 0.4$	—	—	V
"L" level input voltage		V_{IL}	Schmitt trigger input	—	—	$0.3 V_{CC} - 0.4$	V
"H" level input voltage	PS_{IF} ,	V_{IH}	—	$0.7 V_{CC}$	—	—	V
"L" level input voltage	PS_{RF}	V_{IL}	—	—	—	$0.3 V_{CC}$	V
"H" level input current	Data, LE, Clock,	I_{IH}^{*4}	—	-1.0	—	+1.0	μA
"L" level input current	PS_{IF} , PS_{RF}	I_{IL}^{*4}	—	-1.0	—	+1.0	μA
"H" level input current	OSC_{IN}	I_{IH}	—	0	—	+100	μA
"L" level input current		I_{IL}^{*4}	—	-100	—	0	μA
"H" level output voltage	LD/fout	V_{OH}	$V_{CC} = V_p = 2.7\text{ V}$, $I_{OH} = -1\text{ mA}$	$V_{CC} - 0.4$	—	—	V
"L" level output voltage		V_{OL}	$V_{CC} = V_p = 2.7\text{ V}$, $I_{OL} = 1\text{ mA}$	—	—	0.4	V
"H" level output voltage	DO_{IF} , DO_{RF}	V_{DOH}	$V_{CC} = V_p = 2.7\text{ V}$, $I_{DOH} = -0.5\text{ mA}$	$V_p - 0.4$	—	—	V
"L" level output voltage		V_{DOL}	$V_{CC} = V_p = 2.7\text{ V}$, $I_{DOL} = 0.5\text{ mA}$	—	—	0.4	V
High impedance cutoff current	DO_{IF} , DO_{RF}	I_{OFF}	$V_{CC} = V_p = 2.7\text{ V}$ $V_{OFF} = 0.5\text{ V to }V_p - 0.5\text{ V}$	—	—	2.5	nA
"H" level output current	LD/fout	I_{OH}^{*4}	$V_{CC} = V_p = 2.7\text{ V}$	—	—	-1.0	mA
"L" level output current		I_{OL}	$V_{CC} = V_p = 2.7\text{ V}$	1.0	—	—	mA

(Continued)

(Continued)

($V_{CC} = 2.4\text{ V to }3.6\text{ V}$, $T_a = -40\text{ }^\circ\text{C to }+85\text{ }^\circ\text{C}$)

Parameter	Symbol	Condition	Value			Unit		
			Min.	Typ.	Max.			
“H” level output current	DoIF ^{*8} DoRF	I _{DOH} ^{*4}	$V_{CC} = V_p = 2.7\text{ V}$, $V_{DOH} = V_p / 2$, $T_a = +25\text{ }^\circ\text{C}$	CS bit = “H”	-8.2	-6.0	-4.1	mA
				CS bit = “L”	-2.2	-1.5	-0.8	mA
“L” level output current	DoIF ^{*8} DoRF	I _{DOL}	$V_{CC} = V_p = 2.7\text{ V}$, $V_{DOL} = V_p / 2$, $T_a = +25\text{ }^\circ\text{C}$	CS bit = “H”	4.1	6.0	8.2	mA
				CS bit = “L”	0.8	1.5	2.2	mA
Charge pump current rate	I _{DOL} /I _{DOH}	I _{DOMT} ^{*5}	$V_{DO} = V_p / 2$	—	3	—	%	
	vs. V _{DO}	I _{DOVD} ^{*6}	$0.5\text{ V} \leq V_{DO} \leq V_p - 0.5\text{ V}$	—	10	—	%	
	vs. T _a	I _{DOTA} ^{*7}	$-40\text{ }^\circ\text{C} \leq T_a \leq +85\text{ }^\circ\text{C}$, $V_{DO} = V_p / 2$	—	5	—	%	

*1 : Conditions ; fosc = 12.8 MHz, T_a = +25 °C, SW = “L” in locking state.

*2 : V_{CCIF} = V_{pIF} = V_{CCRF} = V_{pRF} = 2.7 V, fosc = 12.8 MHz, T_a = +25 °C, in power saving mode
PS_{IF} = PS_{RF} = GND, V_{IH} = V_{CC} V_{IL} = GND (at CLK, Data, LE)

*3 : AC coupling. 1000 pF capacitor is connected under the condition of Min. operating frequency.

*4 : The symbol “-” (minus) means the direction of current flow.

*5 : $V_{CC} = V_p = 2.7\text{ V}$, $T_a = +25\text{ }^\circ\text{C}$ $(|I_3| - |I_4|) / [(|I_3| + |I_4|) / 2] \times 100\text{ }(\%)$

*6 : $V_{CC} = V_p = 2.7\text{ V}$, $T_a = +25\text{ }^\circ\text{C}$ $(|I_2| - |I_1|) / 2 / [(|I_1| + |I_2|) / 2] \times 100\text{ }(\%)$ (Applied to both I_{DOL} and I_{DOH})

*7 : $V_{CC} = V_p = 2.7\text{ V}$, $(|I_{DO(+85^\circ\text{C})}| - |I_{DO(-40^\circ\text{C})}|) / 2 / [(|I_{DO(+85^\circ\text{C})}| + |I_{DO(-40^\circ\text{C})}|) / 2] \times 100\text{ }(\%)$ (Applied to both I_{DOL} and I_{DOH})

*8 : When Charge pump current is measured, set LDS = “L”, T1 = “L” and T2 = “H”.

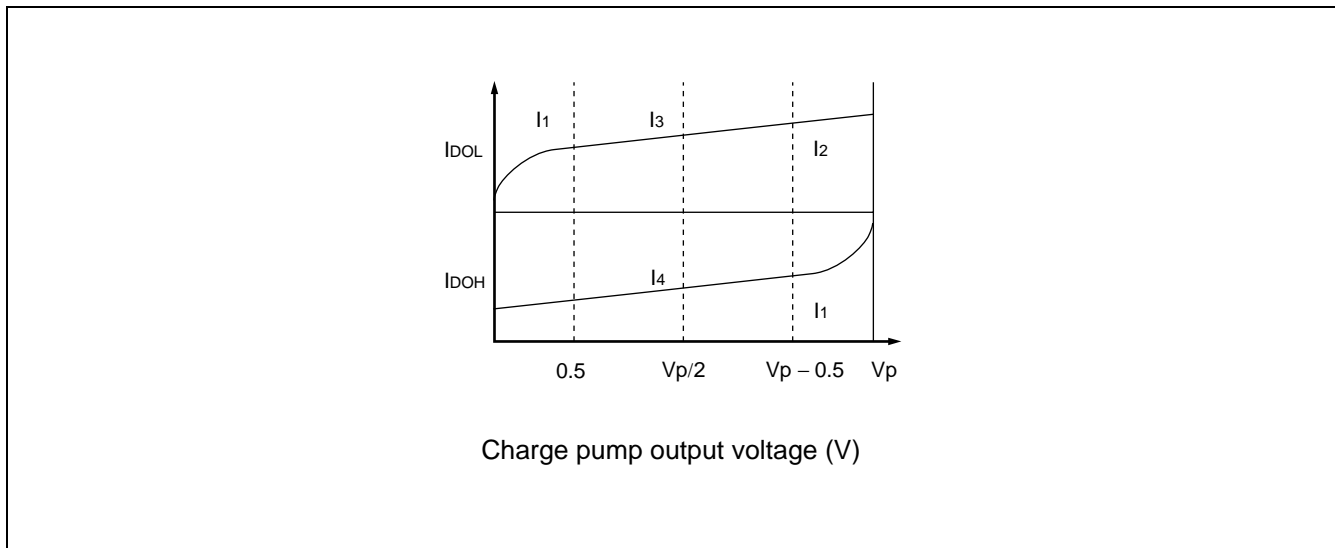

MB15F72UL

FUNCTIONAL DESCRIPTION

1. Pulse swallow function :

$$f_{VCO} = [(P \times N) + A] \times f_{osc} \div R$$

f_{VCO} : Output frequency of external voltage controlled oscillator (VCO)

P : Preset divide ratio of dual modulus prescaler (8 or 16 for IF-PLL, 64 or 128 for RF-PLL)

N : Preset divide ratio of binary 11-bit programmable counter (3 to 2,047)

A : Preset divide ratio of binary 7-bit swallow counter ($0 \leq A \leq 127, A < N$)

f_{osc} : Reference oscillation frequency (OSC_{IN} input frequency)

R : Preset divide ratio of binary 14-bit programmable reference counter (3 to 16,383)

2. Serial Data Input

The serial data is entered using three pins, Data pin, Clock pin, and LE pin. Programmable dividers of IF/RF-PLL sections, and programmable reference dividers of IF/RF-PLL sections are controlled individually. The serial data of binary data is entered through Data pin.

On a rising edge of Clock, one bit of the serial data is transferred into the shift register. On a rising edge of load enable signal, the data stored in the shift register is transferred to one of latches depending upon the control bit data setting.

	The programmable reference counter for the IF-PLL	The programmable reference counter for the RF-PLL	The programmable counter and the swallow counter for the IF-PLL	The programmable counter and the swallow counter for the RF-PLL
CN1	0	1	0	1
CN2	0	0	1	1

(1) Shift Register Configuration

• Programmable Reference Counter

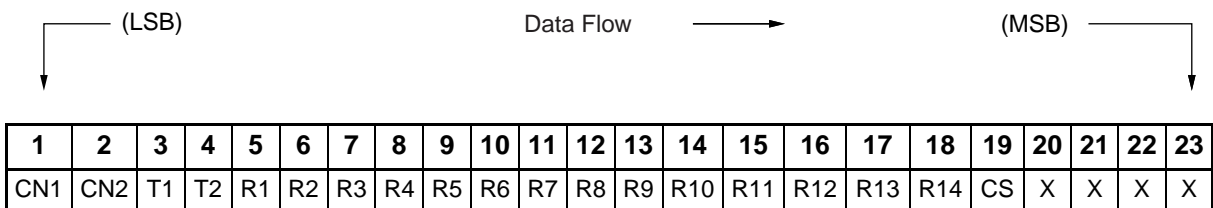

CS : Charge pump current select bit

R1 to R14 : Divide ratio setting bits for the programmable reference counter (3 to 16,383)

T1, T2 : LD/fout output setting bit.

CN1, CN2 : Control bit

X : Dummy bits (Set "0" or "1")

Note : Data input with MSB first.

• **Programmable Counter**

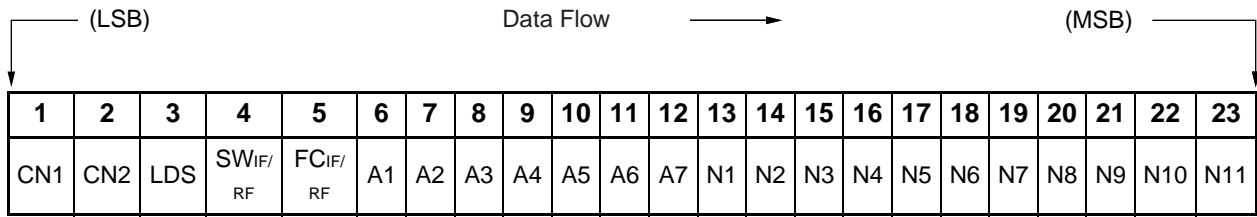

- A1 to A7 : Divide ratio setting bits for the swallow counter (0 to 127)
- N1 to N11 : Divide ratio setting bits for the programmable counter (3 to 2,047)
- LDS : LD/fout signal select bit
- SW_{IF/RF} : Divide ratio setting bit for the prescaler (IF : SW_{IF}, RF : SW_{RF})
- FC_{IF/RF} : Phase control bit for the phase detector (IF : FC_{IF}, RF : FC_{RF})
- CN1, CN2 : Control bit

Note : Data input with MSB first.

(2) Data setting

• Binary 14-bit Programmable Reference Counter Data Setting (R1 to R14)

Divide ratio	R14	R13	R12	R11	R10	R9	R8	R7	R6	R5	R4	R3	R2	R1
3	0	0	0	0	0	0	0	0	0	0	0	0	1	1
4	0	0	0	0	0	0	0	0	0	0	0	1	0	0
•	•	•	•	•	•	•	•	•	•	•	•	•	•	•
•	•	•	•	•	•	•	•	•	•	•	•	•	•	•
•	•	•	•	•	•	•	•	•	•	•	•	•	•	•
16383	1	1	1	1	1	1	1	1	1	1	1	1	1	1

Note : Divide ratio less than 3 is prohibited.

• Binary 11-bit Programmable Counter Data Setting (N1 to N11)

Divide ratio	N11	N10	N9	N8	N7	N6	N5	N4	N3	N2	N1
3	0	0	0	0	0	0	0	0	0	1	1
4	0	0	0	0	0	0	0	0	1	0	0
•	•	•	•	•	•	•	•	•	•	•	•
•	•	•	•	•	•	•	•	•	•	•	•
•	•	•	•	•	•	•	•	•	•	•	•
2047	1	1	1	1	1	1	1	1	1	1	1

Note : Divide ratio less than 3 is prohibited.

• Binary 7-bit Swallow Counter Data Setting (A1 to A7)

Divide ratio	A7	A6	A5	A4	A3	A2	A1
0	0	0	0	0	0	0	0
1	0	0	0	0	0	0	1
•	•	•	•	•	•	•	•
•	•	•	•	•	•	•	•
•	•	•	•	•	•	•	•
127	1	1	1	1	1	1	1

MB15F72UL

- Prescaler Data Setting (SW)

Divide ratio	SW = "1"	SW = "0"
Prescaler divide ratio IF-PLL	8/9	16/17
Prescaler divide ratio RF-PLL	64/65	128/129

- Charge Pump Current Setting (CS)

Current value	CS
±6.0 mA	1
±1.5 mA	0

- LD/fout output Selectable Bit Setting

LD/fout pin state		LDS	T1	T2
LD output		0	0	0
		0	1	0
		0	1	1
fout outputs	frIF	1	0	0
	frRF	1	1	0
	fpIF	1	0	1
	fpRF	1	1	1

- Phase Comparator Phase Switching Data Setting (FCIF, FCRF)

Phase comparator input	FCIF = "1"	FCRF = "1"	FCIF = "0"	FCRF = "0"
	DoIF	DoRF	DoIF	DoRF
fr > fp	H		L	
fr < fp	L		H	
fr = fp	Z		Z	

Z : High-impedance

Depending upon the VCO and LPF polarity, FC bit should be set.

(1) VCO polarity FC = "1"

(2) VCO polarity FC = "0"

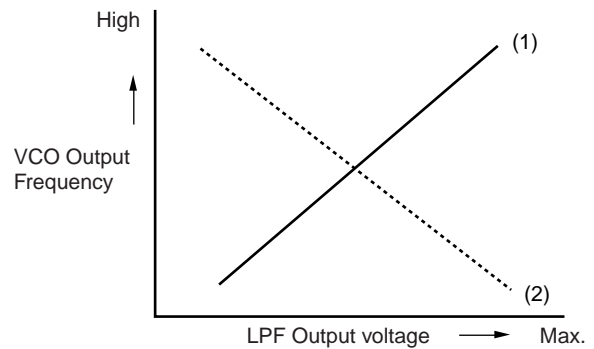

Note : Give attention to the polarity for using active type LPF.

3. Power Saving Mode (Intermittent Mode Control Circuit)

Status	PS _{IF} /PS _{RF} pins
Normal mode	H
Power saving mode	L

The intermittent mode control circuit reduces the PLL power consumption.

By setting the PS pins low, the device enters into the power saving mode, reducing the current consumption. See the Electrical Characteristics chart for the specific value.

The phase detector output, Do, becomes high impedance.

For the dual PLL, the lock detector, LD, is as shown in the LD Output Logic table.

Setting the PS pins high, releases the power saving mode, and the device works normally.

The intermittent mode control circuit also ensures a smooth startup when the device returns to normal operation. When the PLL is returned to normal operation, the phase comparator output signal is unpredictable. This is because of the unknown relationship between the comparison frequency (f_p) and the reference frequency (f_r) which can cause a major change in the comparator output, resulting in a VCO frequency jump and an increase in lockup time.

To prevent a major VCO frequency jump, the intermittent mode control circuit limits the magnitude of the error signal from the phase detector when it returns to normal operation.

- Notes
- When power (V_{CC}) is first applied, the device must be in standby mode, $PS_{IF} = PS_{RF} = \text{Low}$, for at least $1 \mu\text{s}$.
 - PS pins must be set at "L" at Power-ON.

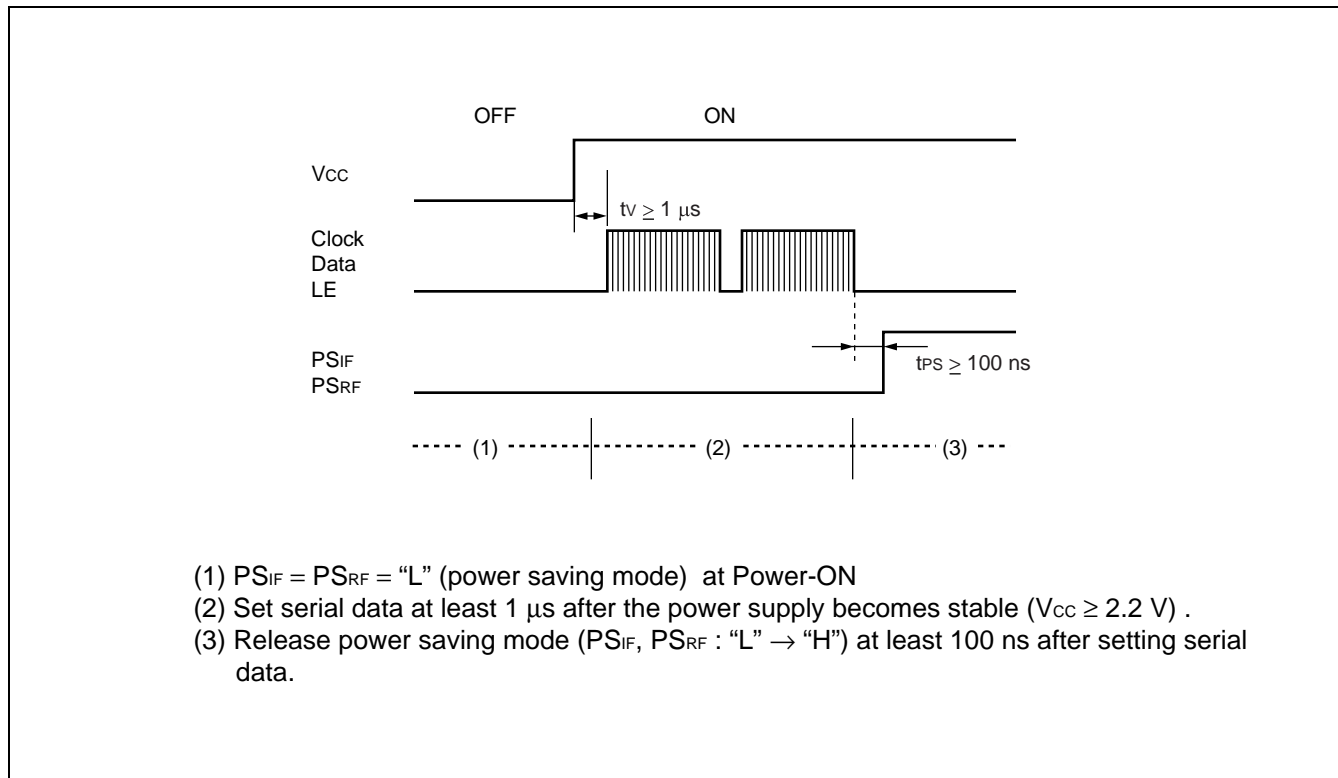

4. Serial Data Input Timing

Frequency multiplier setting is performed through a serial interface using the Data pin, Clock pin, and LE pin. Setting data is read into the shift register at the rise of the clock signal, and transferred to a latch at the rise of the LE signal. The following diagram shows the data input timing.

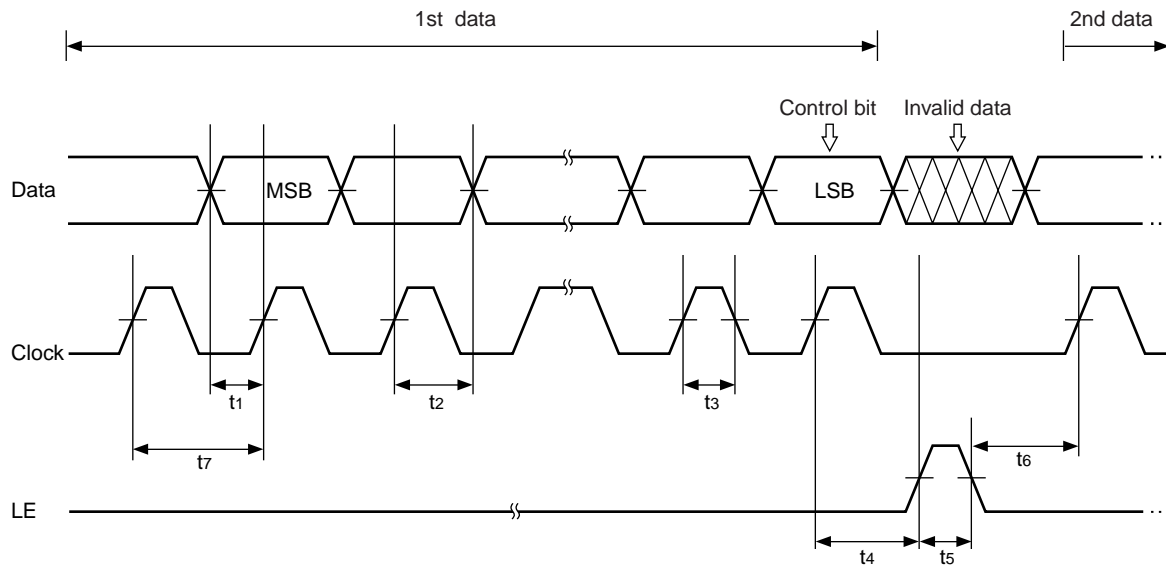

Parameter	Min.	Typ.	Max.	Unit
t_1	20	—	—	ns
t_2	20	—	—	ns
t_3	30	—	—	ns
t_4	30	—	—	ns

Parameter	Min.	Typ.	Max.	Unit
t_5	100	—	—	ns
t_6	20	—	—	ns
t_7	100	—	—	ns

Note : LE should be "L" when the data is transferred into the shift register.

■ PHASE COMPARATOR OUTPUT WAVEFORM

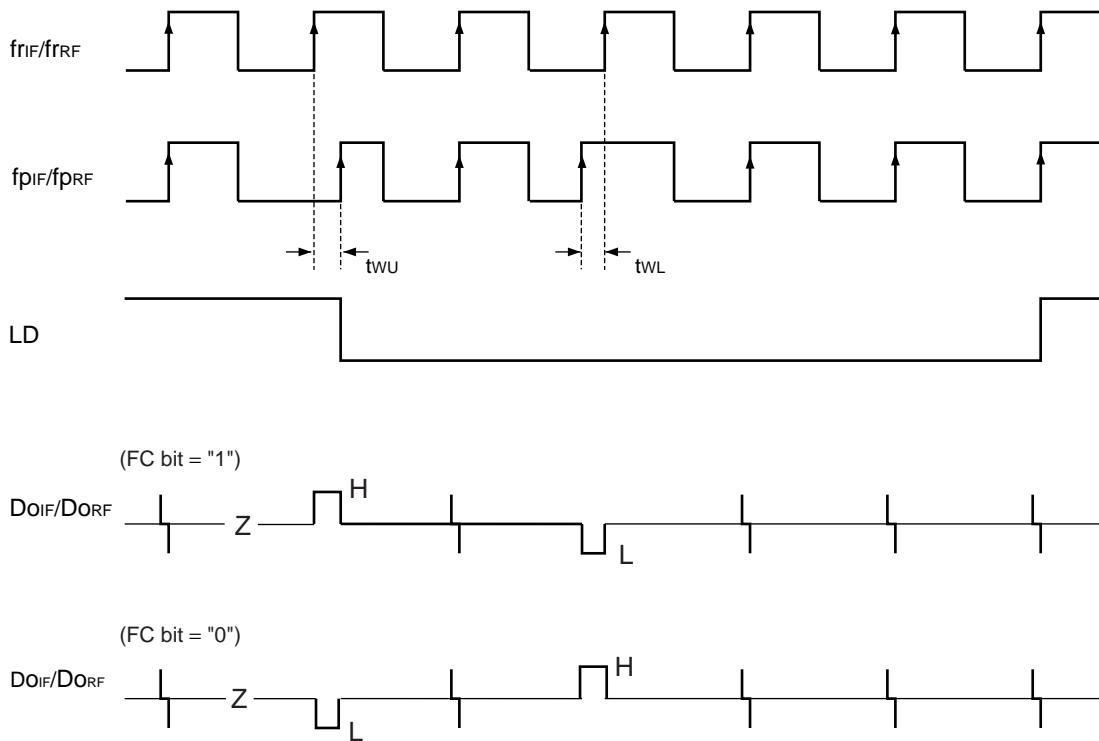

• LD Output Logic

IF-PLL section	RF-PLL section	LD output
Locking state/Power saving state	Locking state/Power saving state	H
Locking state/Power saving state	Unlocking state	L
Unlocking state	Locking state/Power saving state	L
Unlocking state	Unlocking state	L

Notes : • Phase error detection range = -2π to $+2\pi$

- Pulses on DoIF/DoRF signals are output to prevent dead zone during locking state.
- LD output becomes low when phase error is t_{wU} or more.
- LD output becomes high when phase error is t_{wL} or less and continues to be so for three cycles or more.
- t_{wU} and t_{wL} depend on OSC_{IN} input frequency as follows.
 - $t_{wU} \geq 2/f_{osc}$: e.g. $t_{wU} \geq 156.3$ ns when $f_{osc} = 12.8$ MHz
 - $t_{wL} \leq 4/f_{osc}$: e.g. $t_{wL} \leq 312.5$ ns when $f_{osc} = 12.8$ MHz

MB15F72UL

■ TEST CIRCUIT (for Measuring Input Sensitivity f_{in}/OSC_{IN})

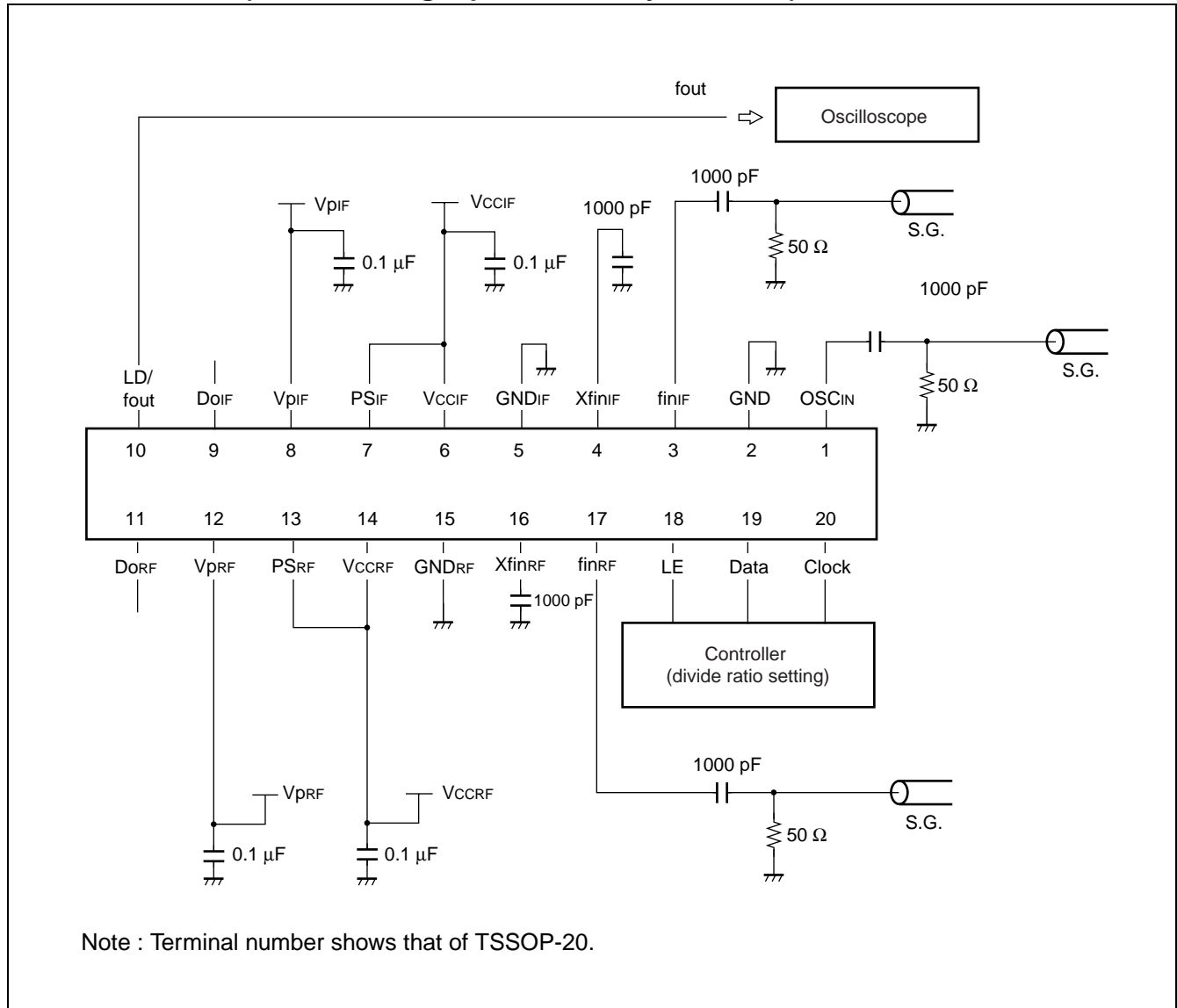

■ TYPICAL CHARACTERISTICS

1. f_{in} input sensitivity

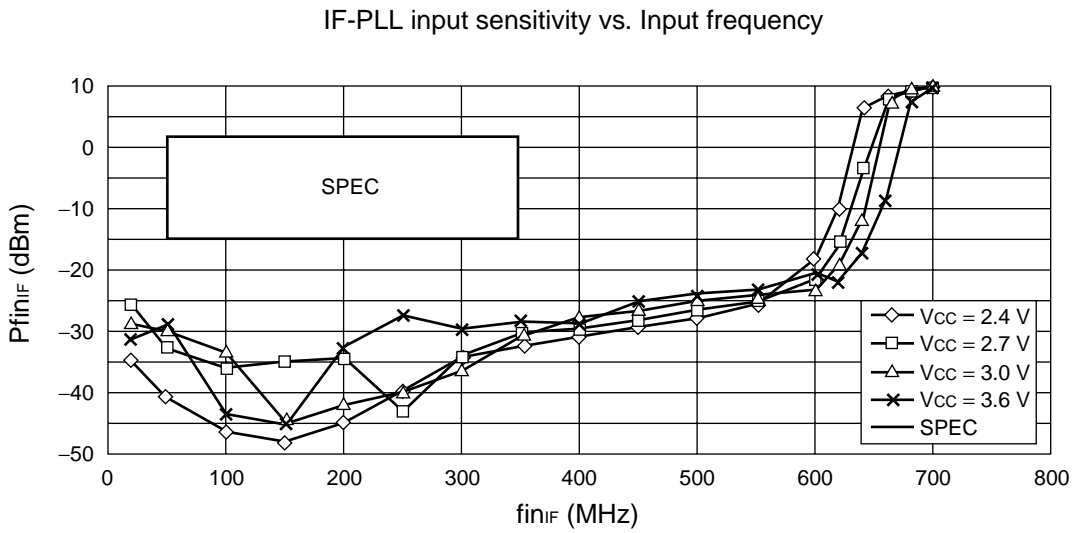
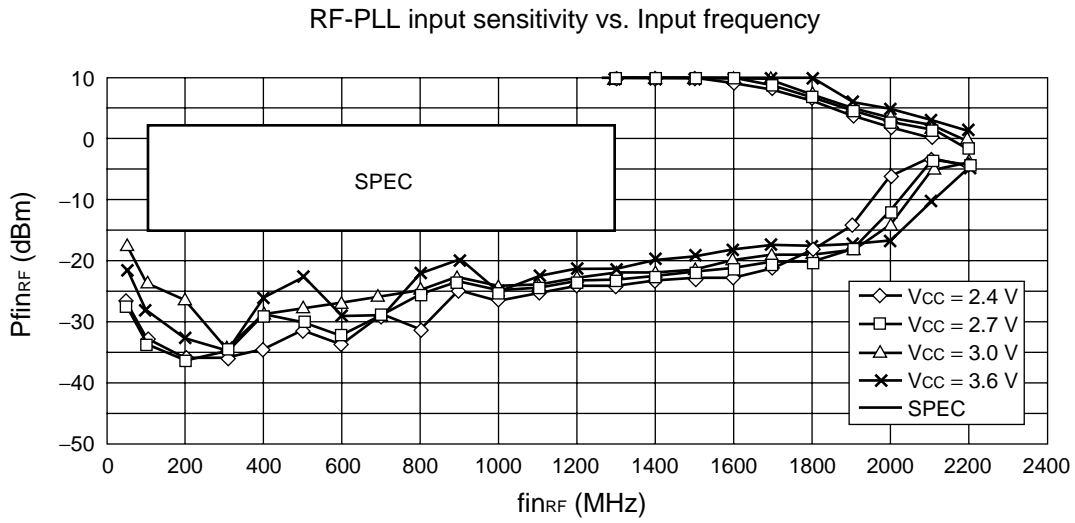

MB15F72UL

2. OSC_{IN} input sensitivity

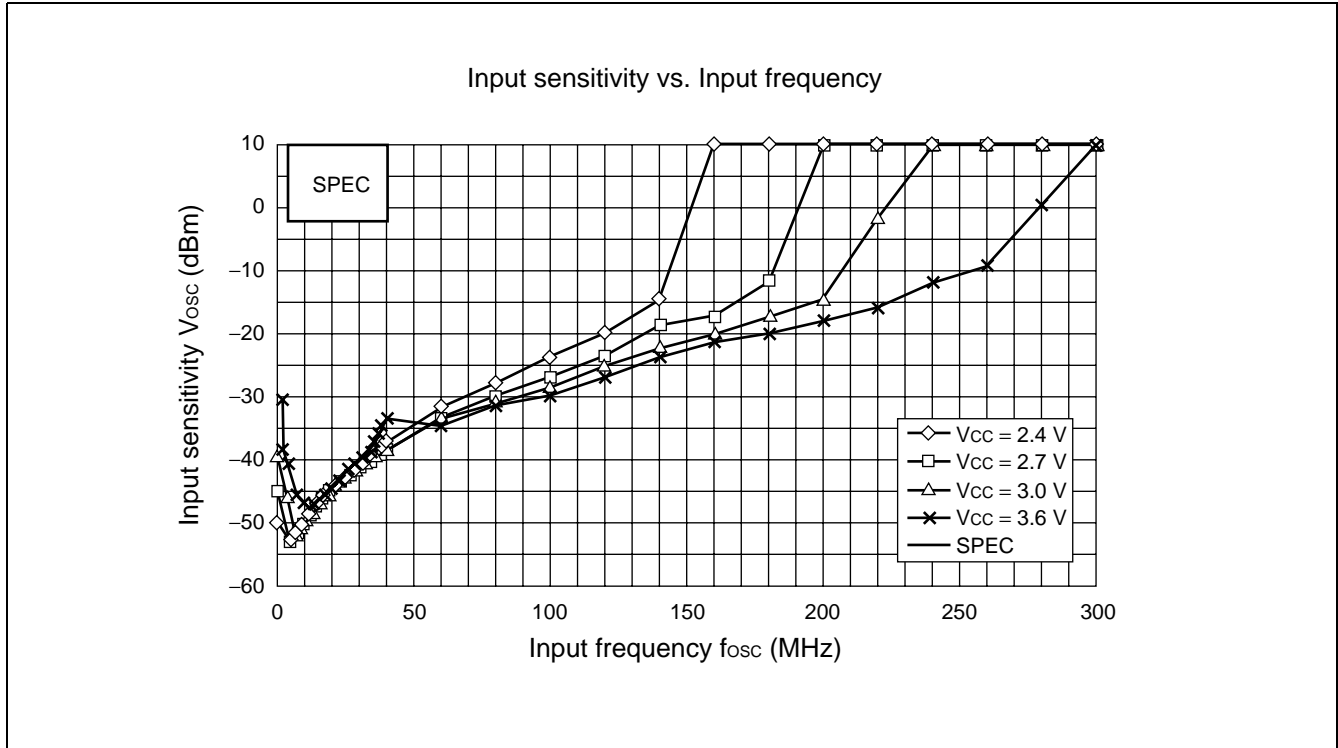

3. RF-PLL Do output current

- 1.5 mA mode

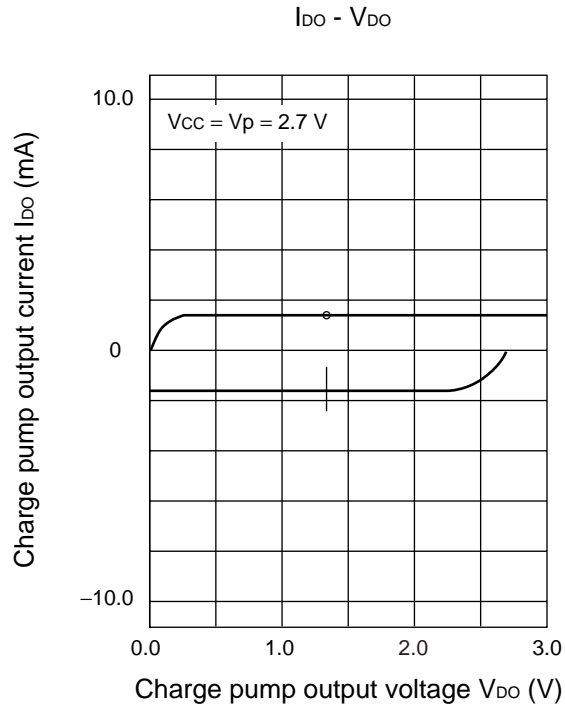

- 6.0 mA mode

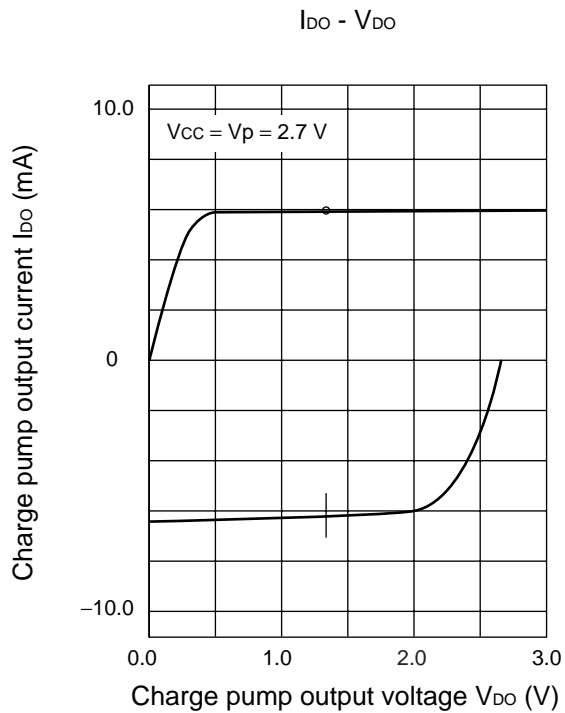

4. IF-PLL Do output current

- 1.5 mA mode

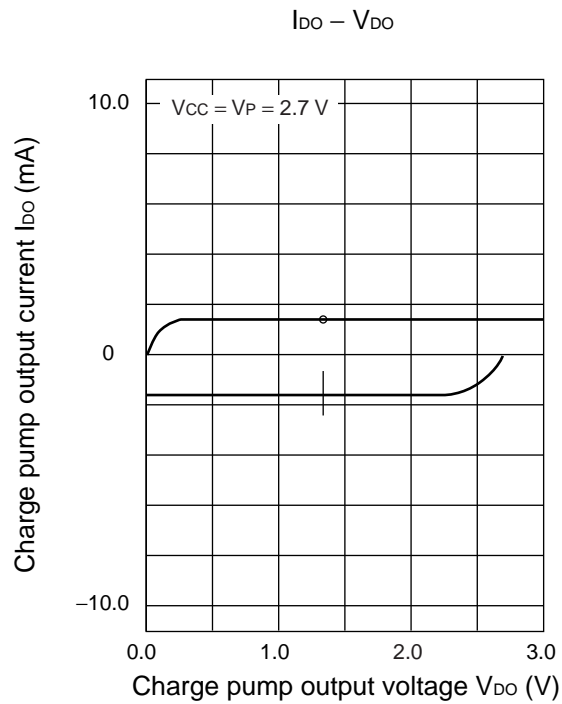

- 6.0 mA mode

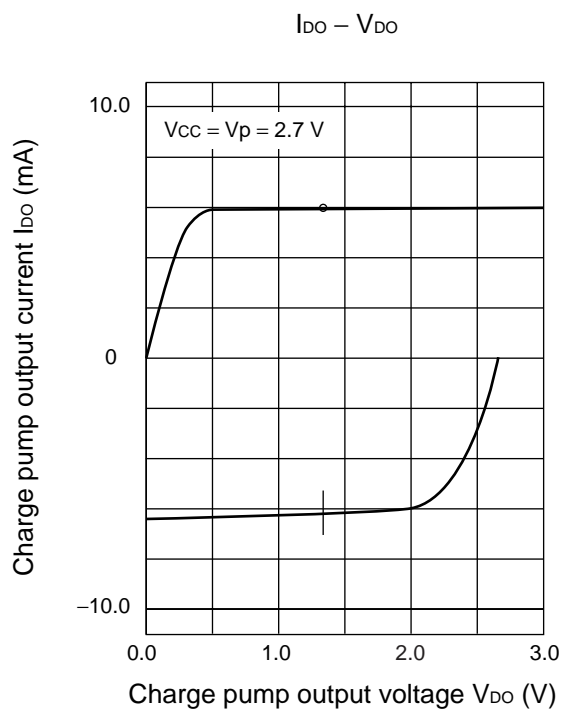

5. fin input impedance

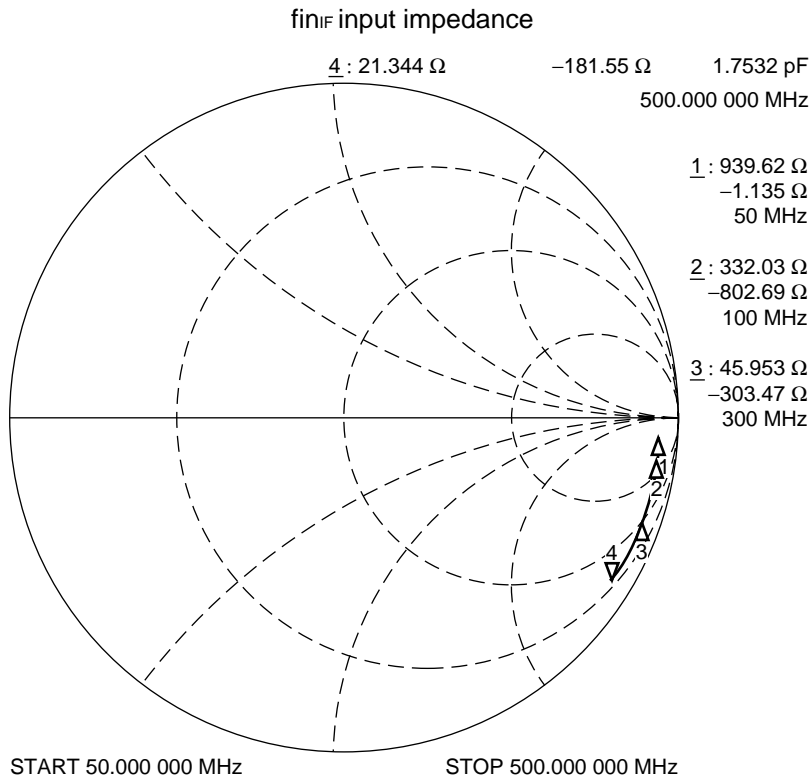
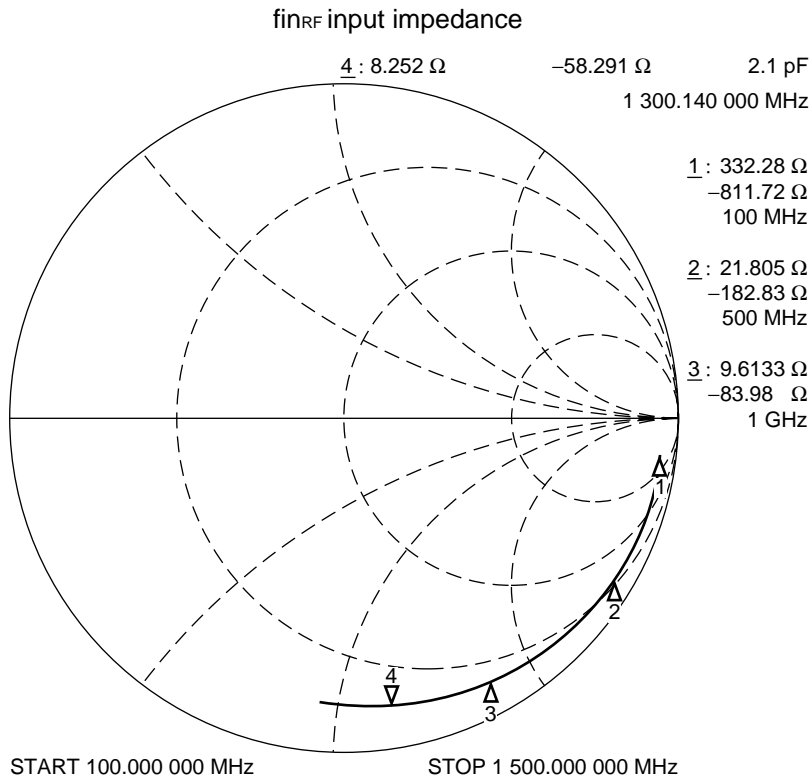

MB15F72UL

6. OSC_{IN} input impedance

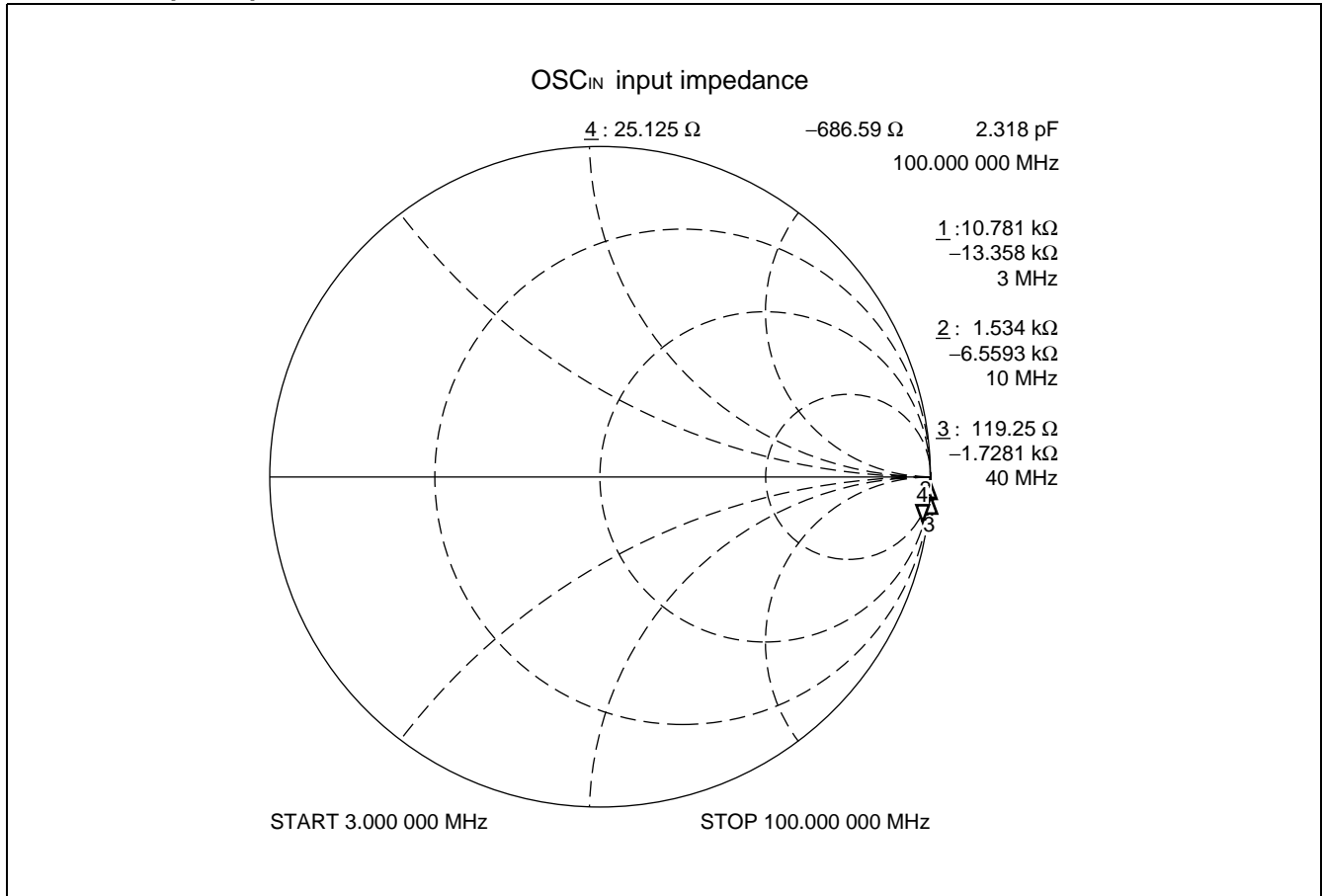

REFERENCE INFORMATION

(for Lock-up Time, Phase Noise and Reference Leakage)

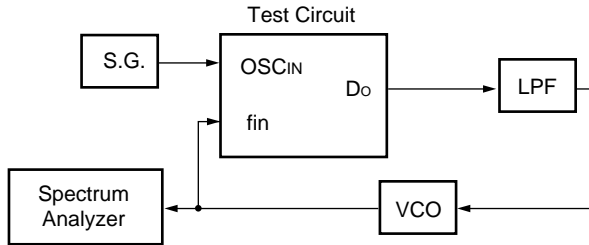

$f_{VCO} = 720.5 \text{ MHz}$ $V_{CC} = 3.0 \text{ V}$
 $K_V = 31$ $V_{VCO} = 3.0 \text{ V}$
 $f_r = 12.5 \text{ kHz}$ $T_a = +25 \text{ }^\circ\text{C}$
 $f_{osc} = 19.2 \text{ MHz}$ $CP : 6 \text{ mA mode}$
 LPF

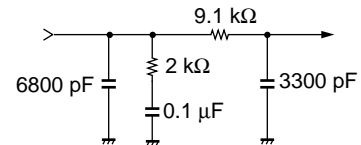

• PLL Reference Leakage

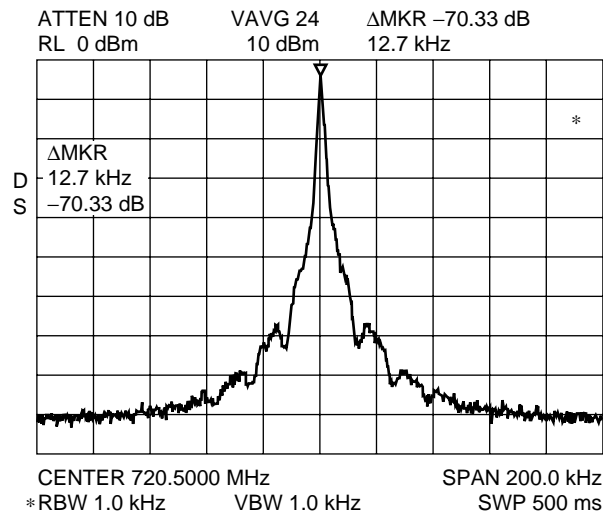

• PLL Phase Noise

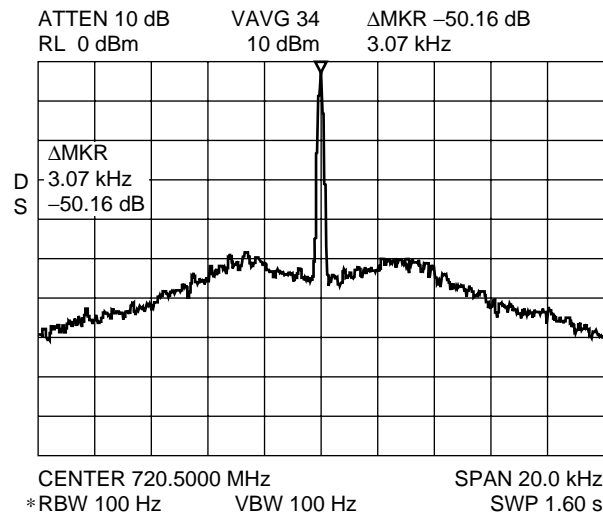

(Continued)

MB15F72UL

(Continued)

• PLL Lock Up time

720.5 MHz → 757.5 MHz within ± 1 kHz
Lch → Hch 2.533 ms

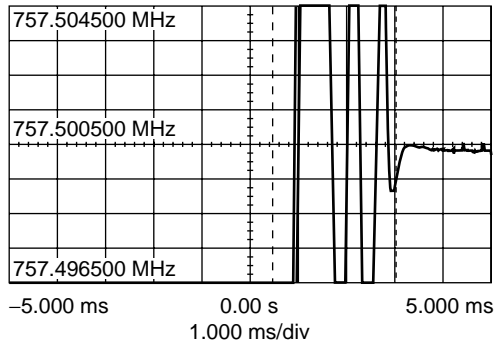

• PLL Lock Up time

757.5 MHz → 720.5 MHz within ± 1 kHz
Hch → Lch 2.511 ms

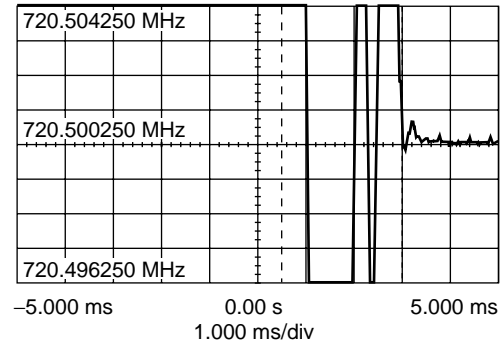

APPLICATION EXAMPLE

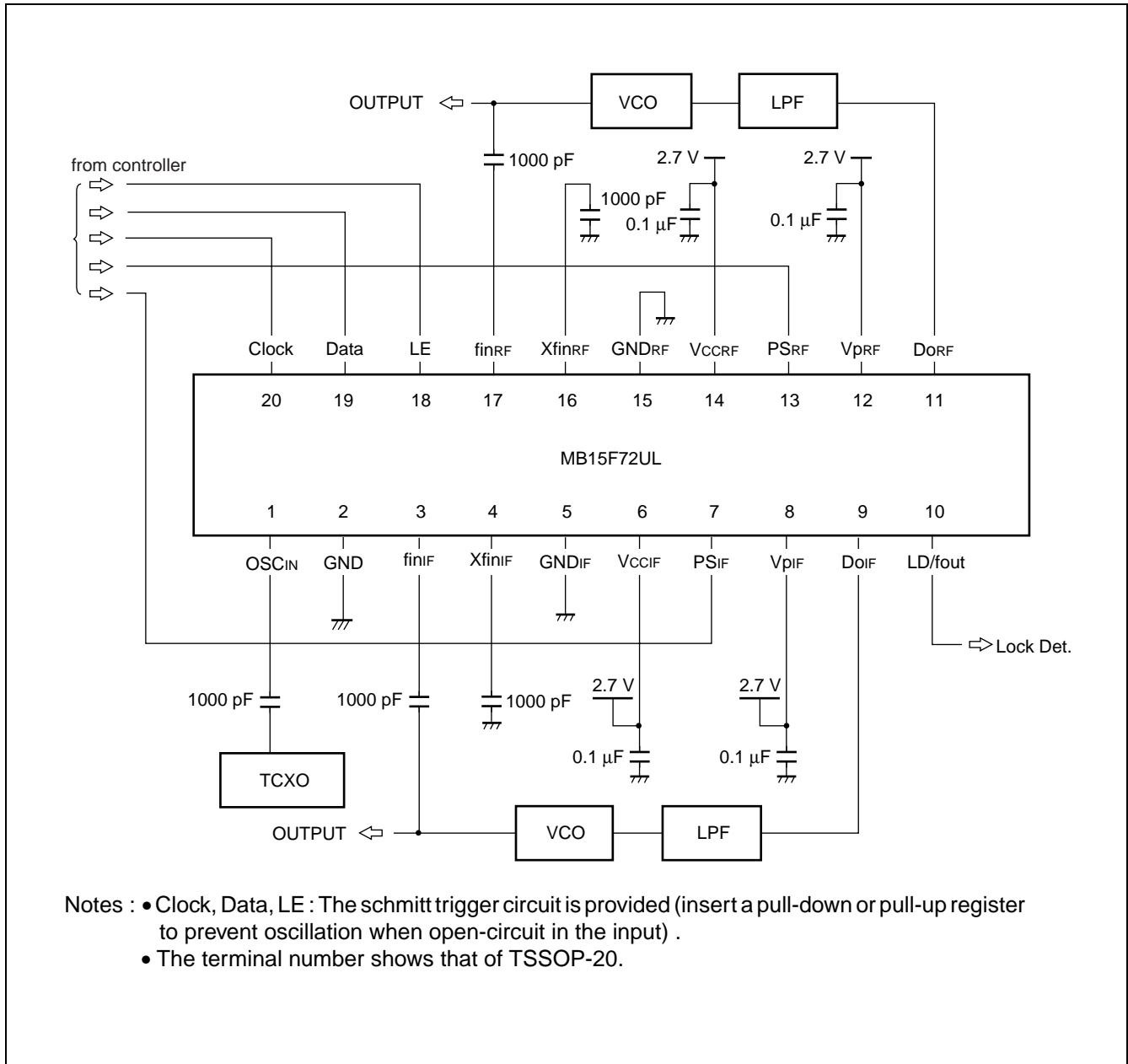

- Notes :
- Clock, Data, LE : The schmitt trigger circuit is provided (insert a pull-down or pull-up register to prevent oscillation when open-circuit in the input) .
 - The terminal number shows that of TSSOP-20.

MB15F72UL

■ USAGE PRECAUTIONS

- (1) V_{CCRF} , V_{PRF} , V_{CCIF} and V_{PIF} must be equal voltage.
Even if either RF-PLL or IF-PLL is not used, power must be supplied to V_{CCRF} , V_{PRF} , V_{CCIF} and V_{PIF} to keep them equal. It is recommended that the non-use PLL is controlled by power saving function.
- (2) To protect against damage by electrostatic discharge, note the following handling precautions :
 - Store and transport devices in conductive containers.
 - Use properly grounded workstations, tools, and equipment.
 - Turn off power before inserting or removing this device into or from a socket.
 - Protect leads with conductive sheet, when transporting a board mounted device.

■ ORDERING INFORMATION

Part number	Package	Remarks
MB15F72ULPFT	20-pin plastic TSSOP (FPT-20P-M06)	
MB15F72ULPVA	20-pad plastic BCC (LCC-20P-M05)	

PACKAGE DIMENSIONS

20-pin plastic TSSOP
(FPT-20P-M06)

Note 1) * : These dimensions do not include resin protrusion.
Note 2) Pins width and pins thickness include plating thickness.

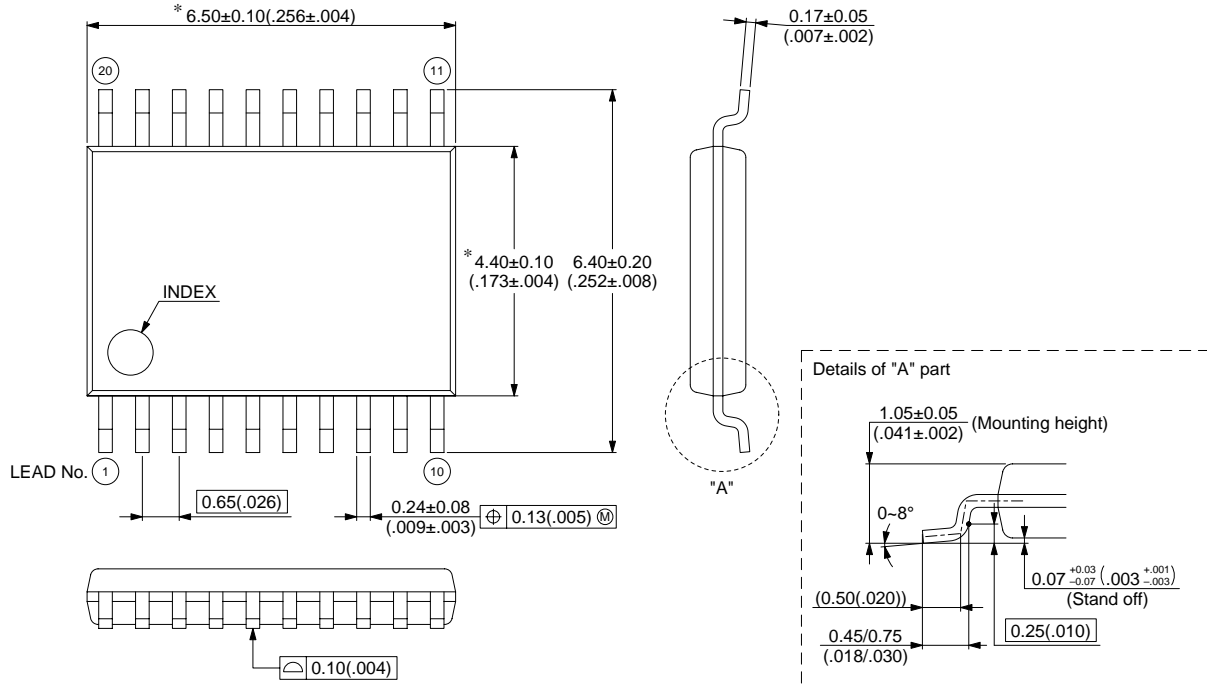

© 1999 FUJITSU LIMITED F20026S-2C-2

Dimensions in mm (inches)

(Continued)

MB15F72UL

(Continued)

20-pad plastic BCC
(LCC-20P-M05)

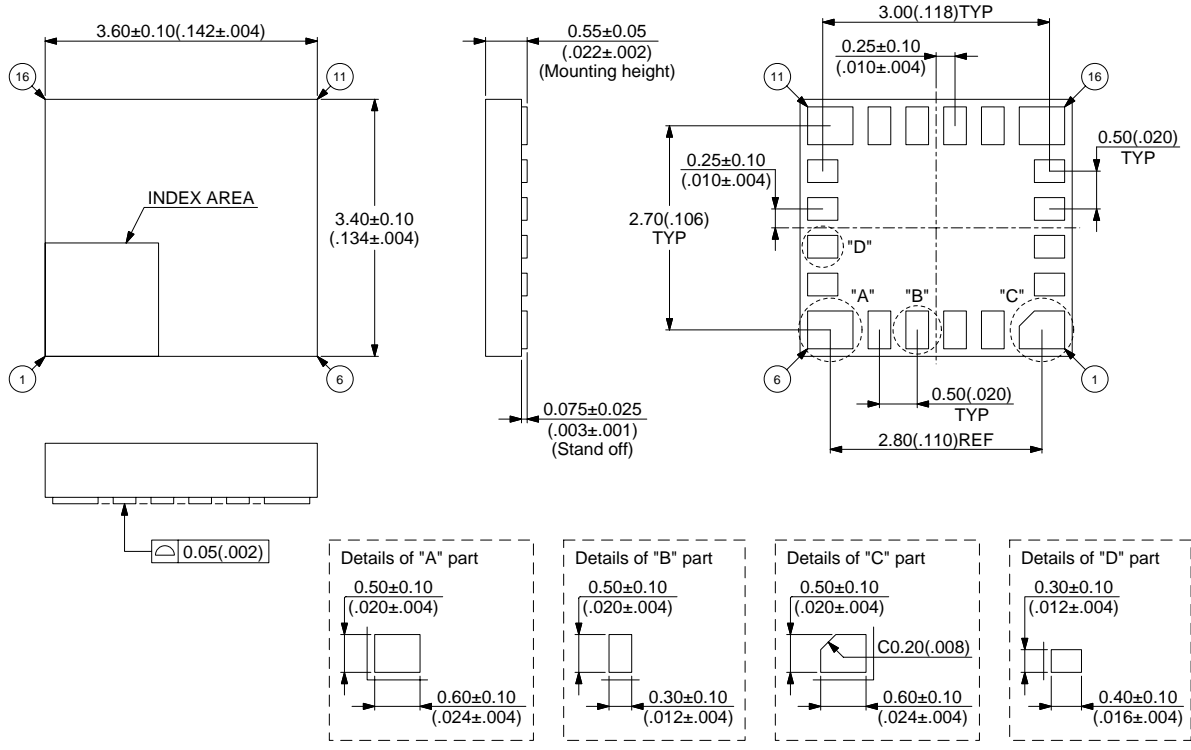

© 2001 FUJITSU LIMITED C20056S-c-2-1

Dimensions in mm (inches)

FUJITSU LIMITED

All Rights Reserved.

The contents of this document are subject to change without notice. Customers are advised to consult with FUJITSU sales representatives before ordering.

The information and circuit diagrams in this document are presented as examples of semiconductor device applications, and are not intended to be incorporated in devices for actual use. Also, FUJITSU is unable to assume responsibility for infringement of any patent rights or other rights of third parties arising from the use of this information or circuit diagrams.

The products described in this document are designed, developed and manufactured as contemplated for general use, including without limitation, ordinary industrial use, general office use, personal use, and household use, but are not designed, developed and manufactured as contemplated (1) for use accompanying fatal risks or dangers that, unless extremely high safety is secured, could have a serious effect to the public, and could lead directly to death, personal injury, severe physical damage or other loss (i.e., nuclear reaction control in nuclear facility, aircraft flight control, air traffic control, mass transport control, medical life support system, missile launch control in weapon system), or (2) for use requiring extremely high reliability (i.e., submersible repeater and artificial satellite).

Please note that Fujitsu will not be liable against you and/or any third party for any claims or damages arising in connection with above-mentioned uses of the products.

Any semiconductor devices have an inherent chance of failure. You must protect against injury, damage or loss from such failures by incorporating safety design measures into your facility and equipment such as redundancy, fire protection, and prevention of over-current levels and other abnormal operating conditions.

If any products described in this document represent goods or technologies subject to certain restrictions on export under the Foreign Exchange and Foreign Trade Law of Japan, the prior authorization by Japanese government will be required for export of those products from Japan.