

Customer Information Sheet

DRAWING No.: M50-360XX42P

IF IN DOUBT - ASK

©

NOT TO SCALE

THIRD ANGLE PROJECTION

ALL DIMENSIONS IN mm

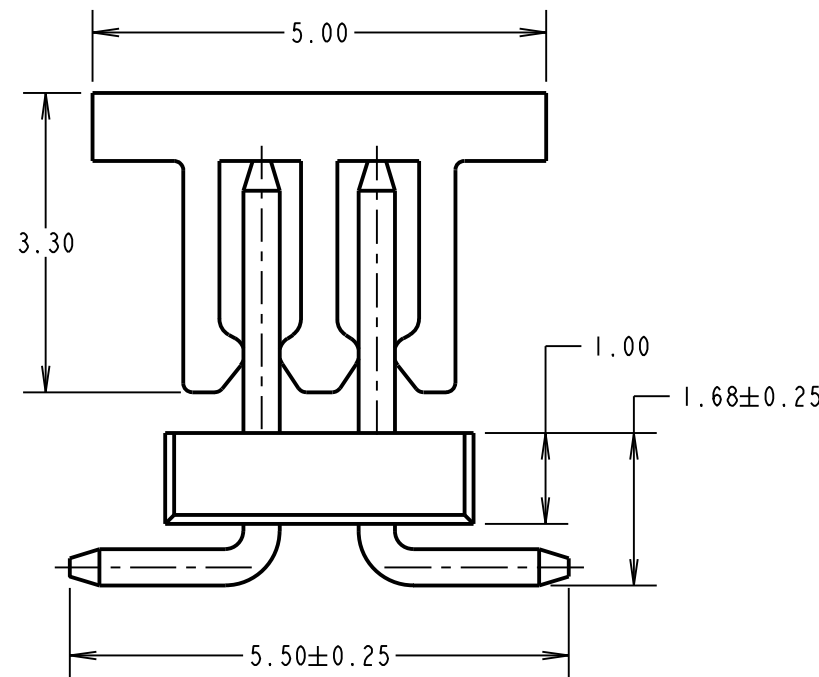
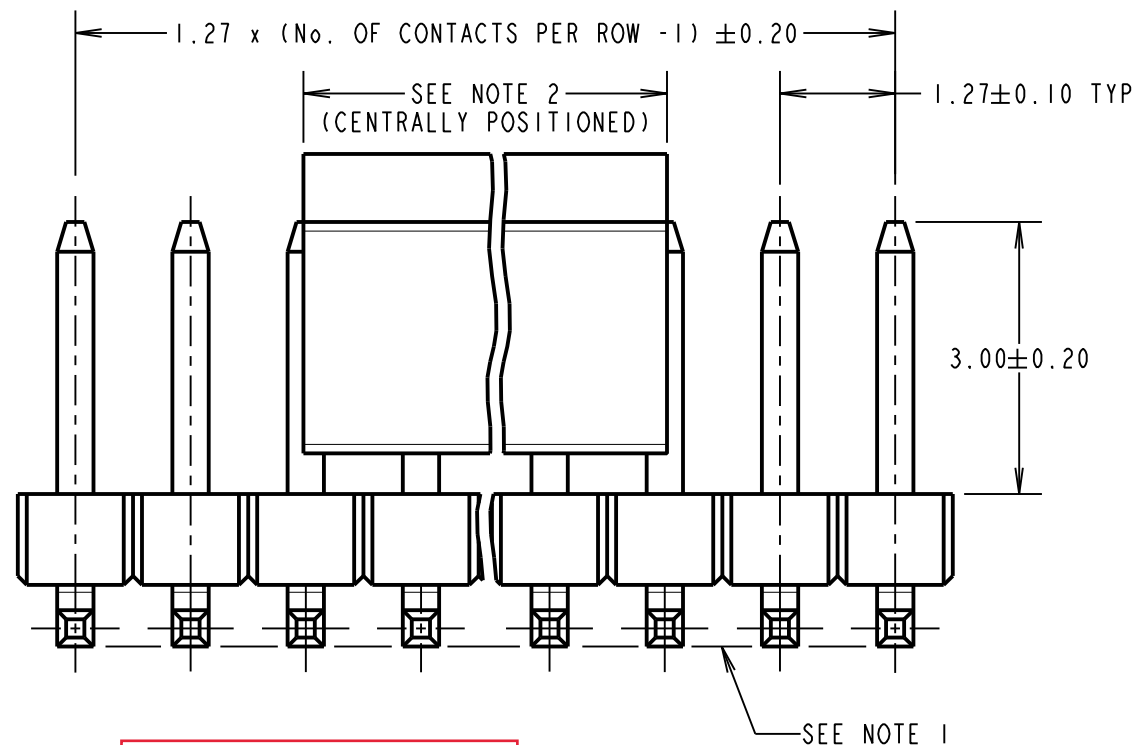
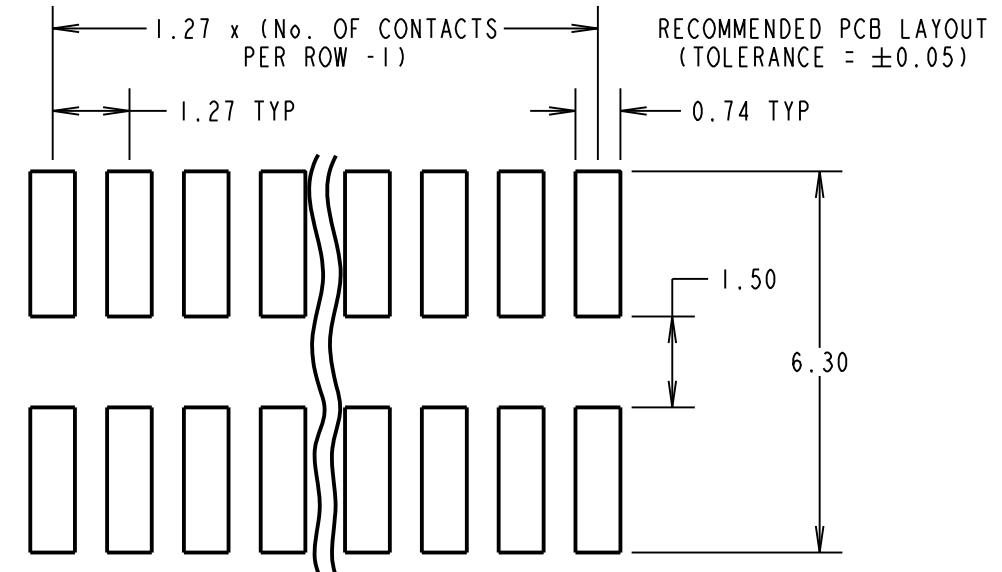
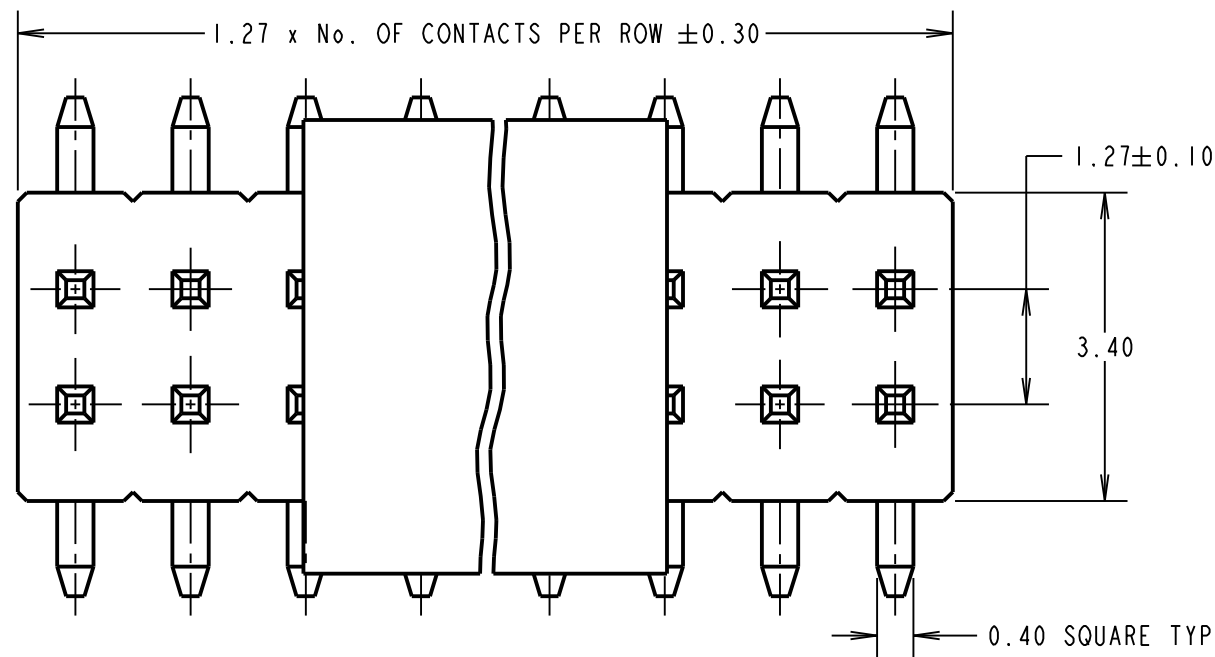

SPECIFICATIONS:

MATERIAL:

MOULDING = HIGH TEMP THERMOPLASTIC, UL94V-0, BLACK

CONTACTS = COPPER ALLOY

FINISH:

CONTACTS = 0.70 TO 1.30 μ NICKEL ALL OVER, 0.08 TO 0.15 μ GOLD ON CONTACT AREA, 2.50 TO 3.00 μ 100% TIN ON TAILS

ELECTRICAL:

CURRENT RATING = 1A

CONTACT RESISTANCE = 20m Ω MAX

INSULATION RESISTANCE = 1000M Ω MIN

DIELECTRIC WITHSTANDING = 1000V AC FOR ONE MINUTE

MECHANICAL:

DURABILITY = 300 CYCLES MIN

ENVIRONMENTAL:

TEMPERATURE RANGE = -40°C TO +105°C

PACKING:

BOX

FOR COMPLETE SPECIFICATION, SEE COMPONENT SPECIFICATION C029XX (LATEST ISSUE)

OBSOLETE

All other size/finish combinations not listed

Active products:

M50-3600542P
M50-3600742P

ORDER CODE:

M50-360XX42P

No. OF CONTACTS PER ROW: _____
02 TO 50

FINISH: _____
42 = SELECTIVE GOLD & 100% TIN OVER NICKEL

NOTES:

- CO-PLANARITY OF TAILS FOR 02 TO 30 CONTACTS PER ROW = 0.15mm, 31 TO 50 CONTACTS PER ROW = 0.20mm.
- PICK AND PLACE CAP LENGTH = 3.60mm FOR 02 TO 05 CONTACTS PER ROW, 6.40mm FOR 06 TO 50 CONTACTS PER ROW.
- ALL TOLERANCES ARE ± 0.15 , UNLESS OTHERWISE STATED.

SB	8	19.03.13	11904
NAME	ISS.	DATE	C/NOTE
APPROVED: S.BENNETT			
CHECKED: S.FLOWER			
DRAWN: J.M.BROOKES			
CUSTOMER REF.:			
ASSEMBLY DRG:			

HARWIN

www.harwin.com
technical@harwin.com

THIS DRAWING AND ANY INFORMATION OR DESCRIPTIVE MATTER SET OUT HEREON ARE CONFIDENTIAL AND COPYRIGHT PROPERTY OF THE HARWIN GROUP AND MUST NOT BE DISCLOSED, LOANED, COPIED OR USED FOR MANUFACTURING, TENDERING OR FOR ANY OTHER PURPOSE WITHOUT THEIR WRITTEN PERMISSION.

TOLERANCES
X = ± 1 mm
X.X = ± 0.25 mm
X.XX = ± 0.10 mm
X.XXX = ± 0.01 mm
ANGLES = $\pm 5^\circ$
UNLESS STATED

MATERIAL:

SEE ABOVE

FINISH:

SEE ABOVE

S/AREA:

mm²

TITLE: 1.27mm PITCH DIL VERTICAL SMT PIN HEADER (WITH PICK & PLACE CAP)

DRAWING NUMBER:

M50-360XX42P

SHT
2 OF 2