

# HONEYWELL

## SS81CA

*See full Datasheet below...*

**onlinecomponents.com**

*THE ONLINE DISTRIBUTOR OF ELECTRONIC COMPONENTS*

**BUY NOW**



**MASTER**<sup>TM</sup>  
ELECTRONICS

**BUY NOW**

masterelectronics.com & onlinecomponents.com  
are **authorized** e-commerce distributors  
of electronic components.

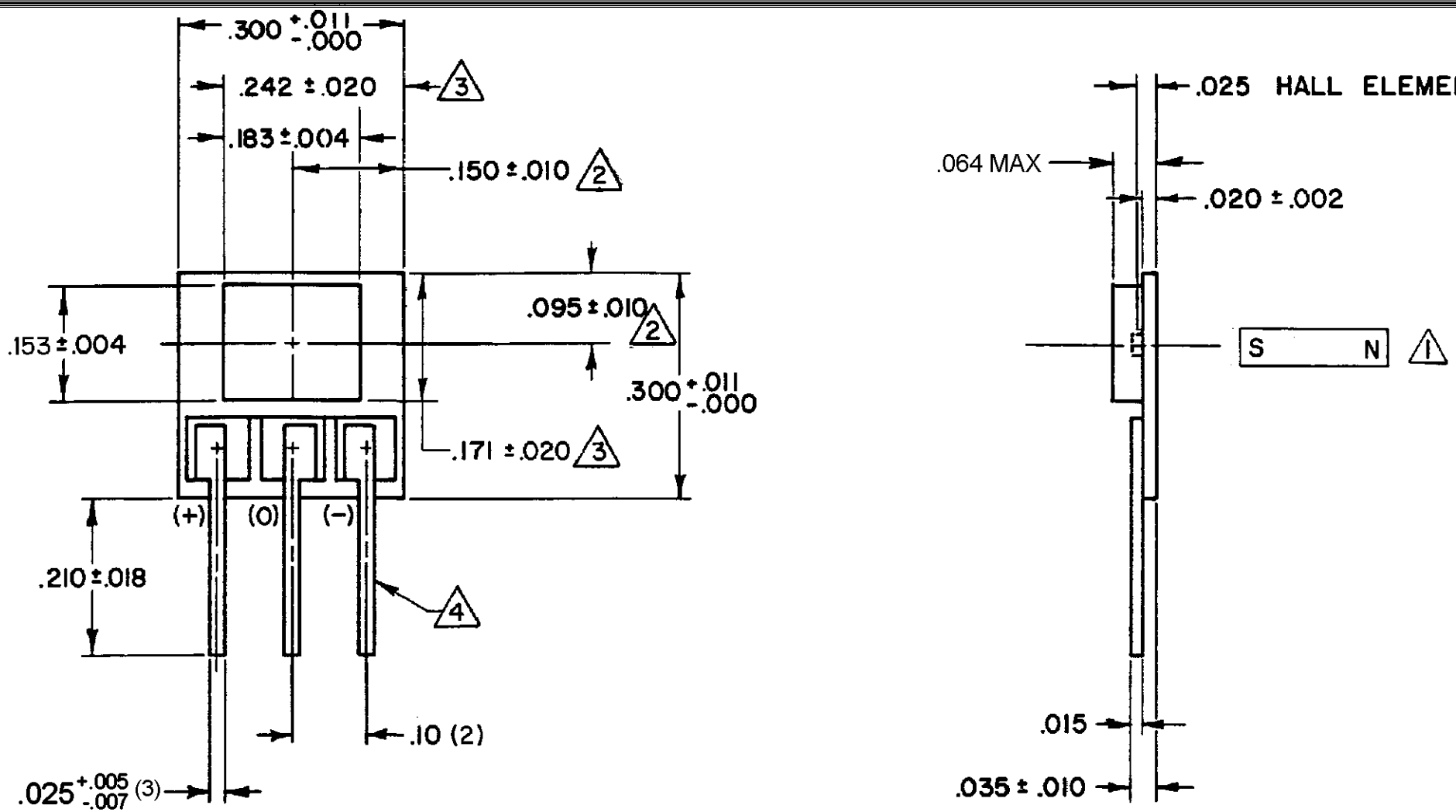

**MAGNETIC CHARACTERISTICS**

TEMP. RANGE	-55°C TO 150°C	-40°C TO 100°C	0°C TO 70°C
OPERATE MAX	190	120	90
OPERATE MIN			
RELEASE MIN	-190	-120	-90
RELEASE MAX			
DIFF MIN	40	40	40

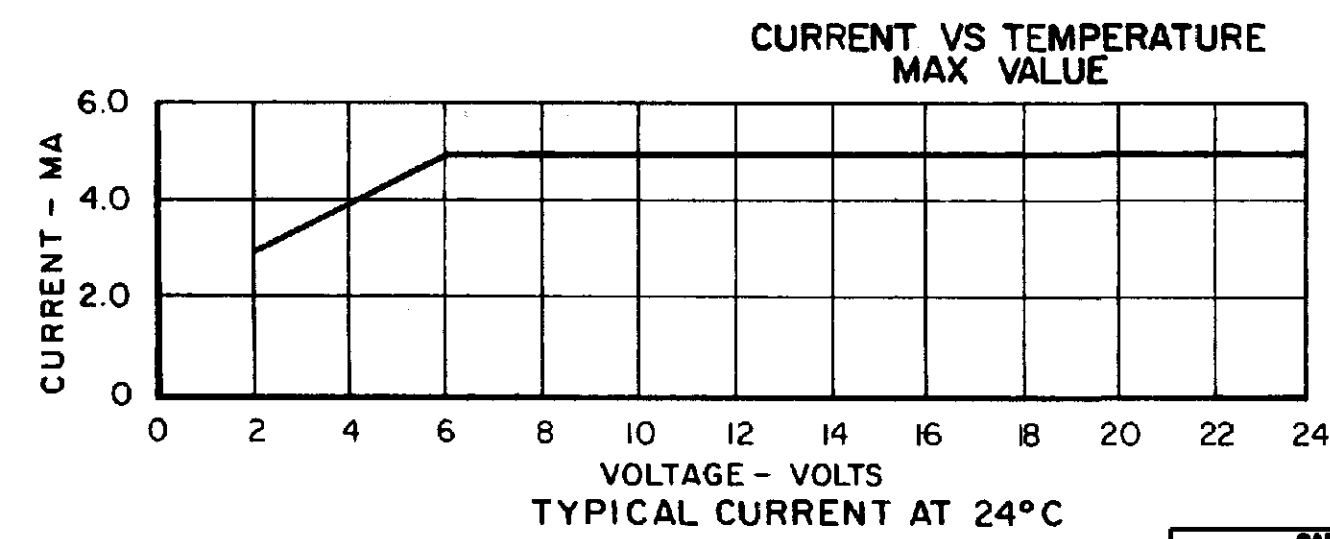
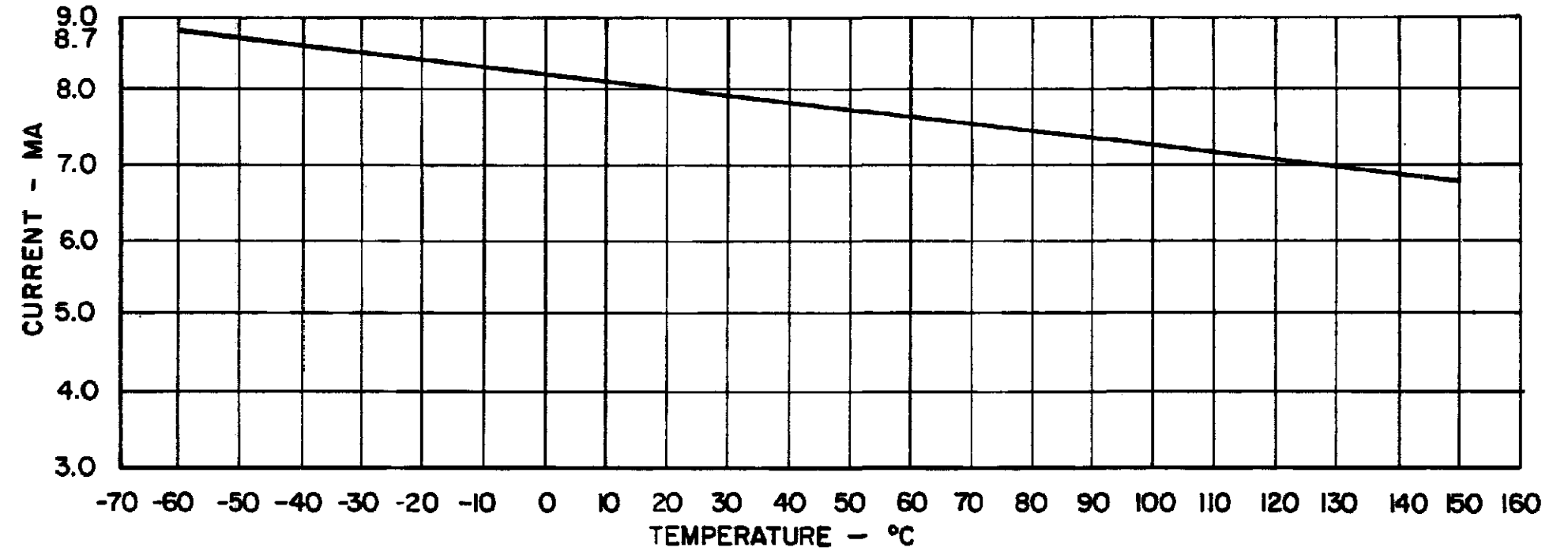
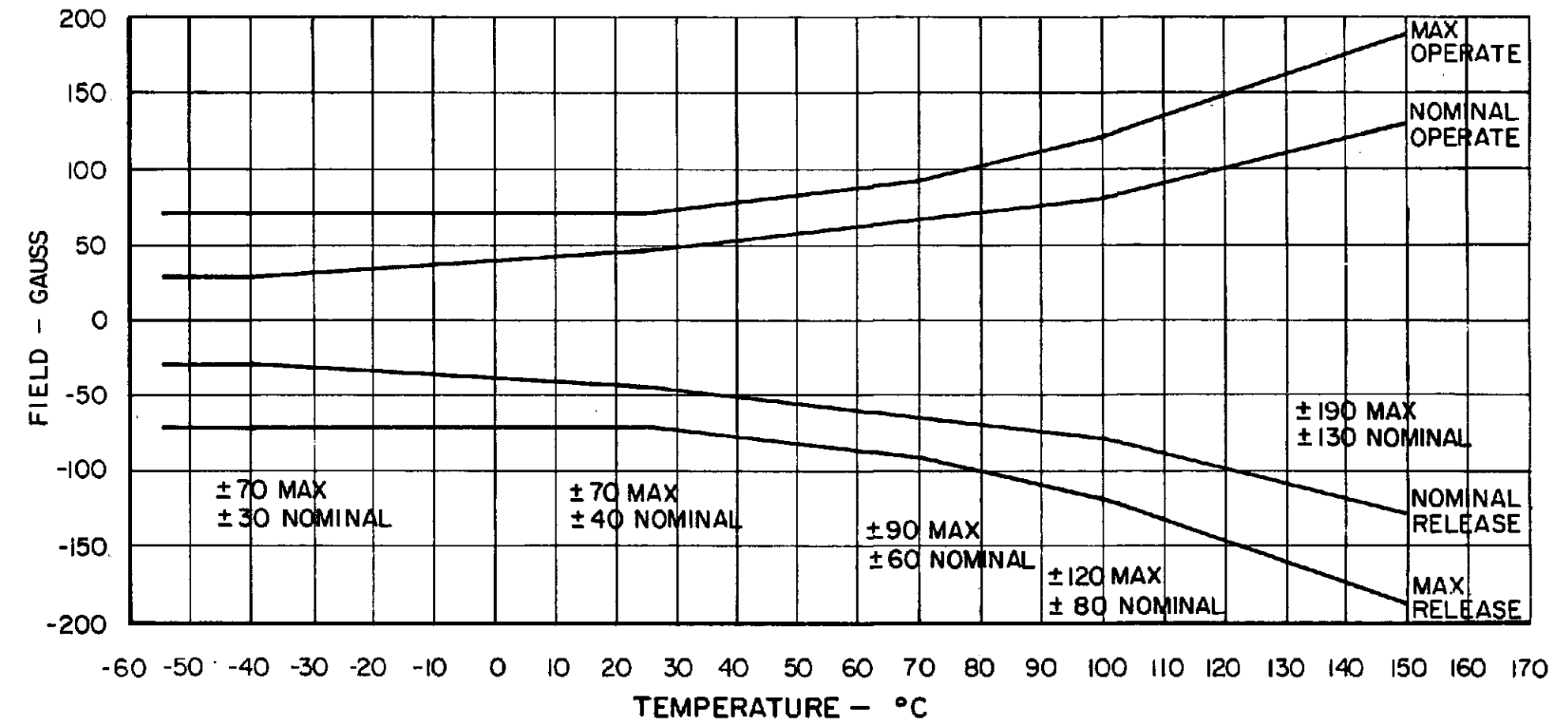

**-55° - 150° C ELECTRICAL CHARACTERISTICS**

	MIN	TYP	MAX	REMARKS
SUPPLY CURRENT			8.7 mA	"OFF" CONDITION 4.5 - 24 VDC
SINK CURRENT			10 mA	
OUTPUT VOLTAGE (OPERATED)		0.15V	0.4 V	SINKING 10 mA MAX
OUTPUT LEAKAGE CURRENT (RELEASED)			10 μA	LEAKAGE INTO SWITCH OUTPUT
OUTPUT SWITCHING TIME (SINKING)				
RISE TIME		0.2 μS	1.5 μS	10% TO 90%
FALL TIME		0.5 μS	1.5 μS	90% TO 10%

**ABSOLUTE MAXIMUM RATING**

SUPPLY VOLTAGE (V <sub>S</sub> )	-34 TO +34 VDC
VOLTAGE EXTERNALLY APPLIED TO OUTPUT	+28.0 VDC MAX WITH SWITCH IN "OFF" CONDITION ONLY -0.5 V MIN WITH SWITCH IN "OFF" OR "ON" CONDITION
OUTPUT CURRENT	20 mA
TEMPERATURE	-55°C TO 160°C
MAGNETIC FLUX	NO LIMIT, THE CIRCUIT CANNOT BE DAMAGED BY MAGNETIC OVERDRIVE

**BLOCK DIAGRAM CURRENT SINKING OUTPUT**

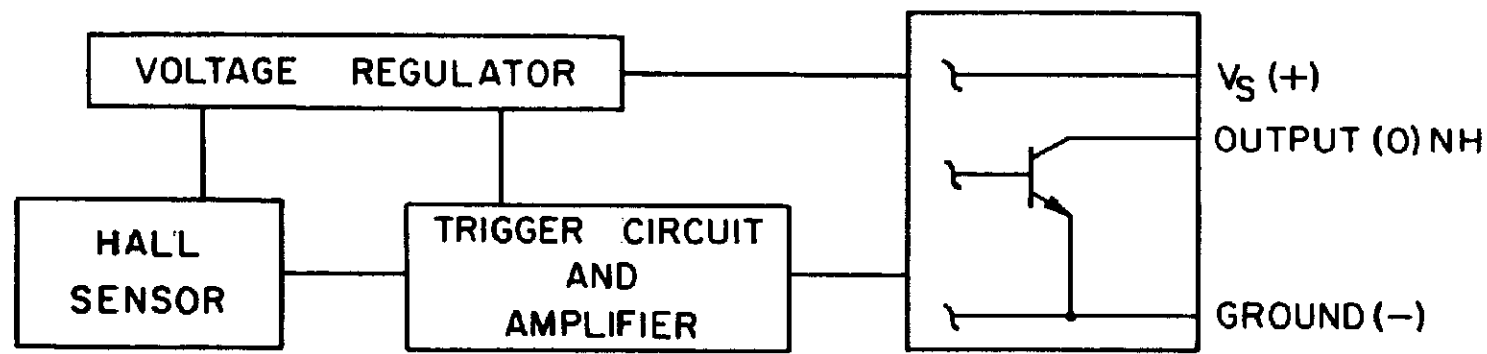

- NOTES**
- 1 TO TEST THE SWITCH AGAINST THE SPECIFIED OPERATING CHARACTERISTICS THE SWITCH MUST BE PLACED IN A UNIFORM MAGNETIC FIELD
  - 2 HALL ELEMENT LOCATION WITH INTEGRATED CIRCUIT PLACEMENT TOLERANCE (IC) ONLY. THE LOCATION OF THE CERAMIC COVER IS NOT SPECIFIED
  - 3 PROTECTIVE CAP PLACEMENT TOLERANCE
  - 4 SOLDER TERMINALS USING 60/40 ROSIN CORE SOLDER EMPLOYING A 750°F CONTROLLED TEMPERATURE 1/8" CHISEL TIP SOLDERING IRON. CAUTION: THE SOLDER TIP SHOULD NEVER BE HELD ON THE TERMINAL FOR OVER 4 SECONDS IN ORDER TO AVOID DELAMINATION OF THE TERMINALS FROM THE CERAMIC
  - 5 ABSOLUTE MAXIMUM RATINGS ARE THE EXTREME LIMITS THAT THE DEVICE WILL WITHSTAND WITHOUT DAMAGE TO THE DEVICE. HOWEVER, THE ELECTRICAL AND MAGNETIC CHARACTERISTICS ARE NOT GUARANTEED AS THE MAXIMUM LIMITS (ABOVE RECOMMENDED OPERATING CONDITIONS) ARE APPROACHED NOR WILL THE DEVICE NECESSARILY OPERATE AT ABSOLUTE MAXIMUM RATING

THIS DRAWING COVERS A PROPRIETARY ITEM AND IS THE PROPERTY OF MICRO SWITCH, A DIVISION OF HONEYWELL. THIS DRAWING IS NOT TO BE COPIED OR USED WITHOUT THE APPROVAL OF MICRO SWITCH.

**MICRO SWITCH**  
a Honeywell Division

**SOLID STATE SWITCH**

CATALOG LISTING  
**SS81CA**

ESD SENSITIVITY:  
CLASS 2

THIRD ANGLE PROJECTION

SCALE **5 : 1**

DO NOT SCALE PRINT

UNLESS OTHERWISE SPECIFIED TOLERANCES ARE

ONE PLACE (.0)	±.030
TWO PLACES (.00)	±.015
THREE PLACES (.000)	±.005
ANGLES	±
WEIGHT	

DRAWING NUMBER: SS81CA  
 RELEASE NO.: PR-12784  
 ISSUE: 8  
 REVISIONS:  
 A 10-19704 DLM 8 MAR 00  
 B 202280 CSL 21 FEB 01  
 C 203955 TSM 21 SEP 01  
 D 0038691 VS 14 APR 08  
 E 0039911 SS 21 MAY 08  
 CHECKED: SAV 8 MAR 00  
 DRAWN: DLM 8 MAR 00  
 RASTER