

Schottky Diode

High Performance Schottky Diode
Low Loss and Soft Recovery
Single Diode

Part number

DSS17-06CR

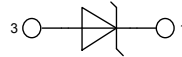

$$\begin{aligned} V_{RRM} &= 600 \text{ V} \\ I_{FAV} &= 17 \text{ A} \\ V_F &= 2.71 \text{ V} \end{aligned}$$

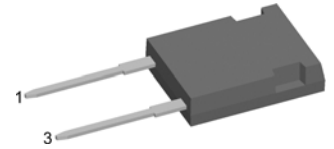

Backside: isolated

 E72873

Features / Advantages:

- Very low V_f
- Extremely low switching losses
- low I_{rm} values
- Improved thermal behaviour
- High reliability circuit operation
- Low voltage peaks for reduced protection circuits
- Low noise switching

Applications:

- Rectifiers in switch mode power supplies (SMPS)
- Free wheeling diode in low voltage converters

Package:

- Housing: ISOPLUS247
- Industry standard outline
- DCB isolated backside
- Isolation Voltage 3000 V
- Epoxy meets UL 94V-0
- RoHS compliant

Ratings

Symbol	Definition	Conditions	Ratings			Unit
			min.	typ.	max.	
V_{RRM}	max. repetitive reverse voltage				600	V
I_R	reverse current	$V_R = 600 \text{ V}$			0.5	mA
		$V_R = 600 \text{ V}$			5	mA
V_F	forward voltage	$I_F = 15 \text{ A}$			3.32	V
		$I_F = 30 \text{ A}$			3.76	V
		$I_F = 15 \text{ A}$			2.71	V
		$I_F = 30 \text{ A}$			3.23	V
I_{FAV}	average forward current	rectangular $d = 0.5$			17	A
V_{F0}	threshold voltage				1.91	V
r_F	slope resistance				33.3	m Ω
R_{thJC}	thermal resistance junction to case				1.40	K/W
T_{VJ}	virtual junction temperature		-55		175	$^{\circ}\text{C}$
P_{tot}	total power dissipation				105	W
I_{FSM}	max. forward surge current	$t = 10 \text{ ms}$ (50 Hz), sine			200	A
C_J	junction capacitance	$V_R = 400 \text{ V}$; $f = 1 \text{ MHz}$		20		pF

Symbol	Definition	Conditions	Ratings			Unit
			min.	typ.	max.	
I_{RMS}	RMS current	per terminal			50	A
R_{thCH}	thermal resistance case to heatsink			0.25		K/W
T_{stg}	storage temperature		-55		150	°C
Weight				6		g
F_C	mounting force with clip		20		120	N
V_{ISOL}	isolation voltage	t = 1 second t = 1 minute	3600 3000			V V
$d_{Spp/App}$	creepage striking distance on surface through air	terminal to terminal	5.5			mm
$d_{Spb/Apb}$	creepage striking distance on surface through air	terminal to backside	5.5			mm

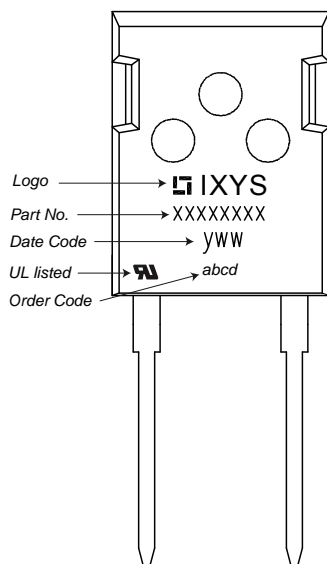
Product Marking

Ordering	Part Name	Marking on Product	Delivering Mode	Base Qty	Code Key
Standard	DSS17-06CR	DSS17-06CR	Tube	30	480266

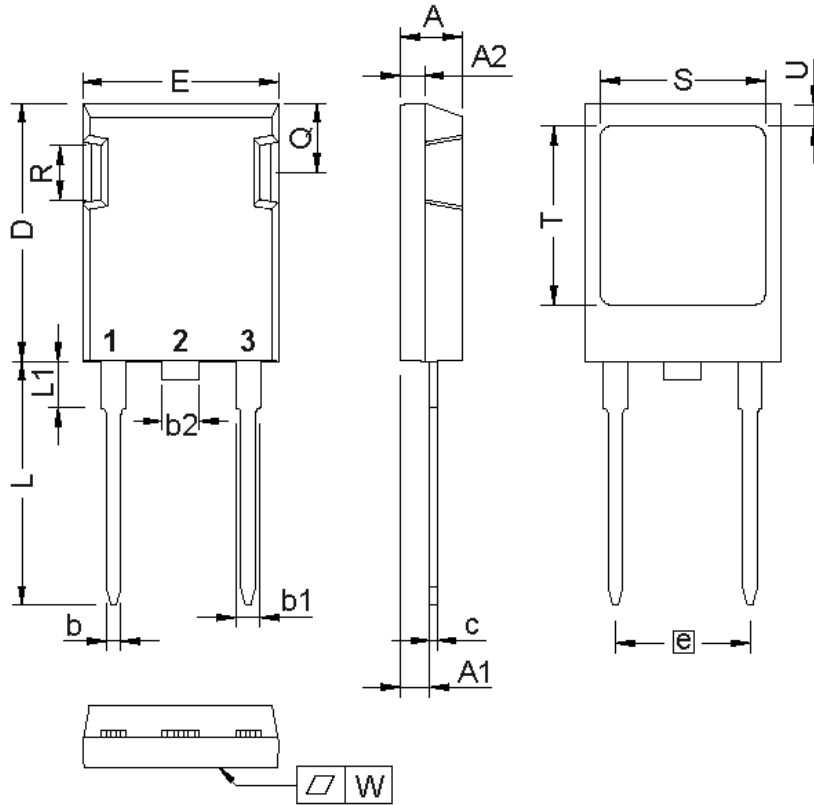
Outlines ISOPLUS247

Dim.	Millimeter		Inches	
	min	max	min	max
A	4.83	5.21	0.190	0.205
A1	2.29	2.54	0.090	0.100
A2	1.91	2.16	0.075	0.085
b	1.14	1.40	0.045	0.055
b1	1.91	2.15	0.075	0.085
b2	2.92	3.20	0.115	0.126
c	0.61	0.83	0.024	0.033
D	20.80	21.34	0.819	0.840
E	15.75	16.13	0.620	0.635
e	10.90 BSC		0.430 BSC	
L	19.81	20.60	0.780	0.811
L1	3.81	4.38	0.150	0.172
L2	0.00	2.54	0.000	0.100
Q	5.59	6.20	0.220	0.244
R	4.32	4.85	0.170	0.191
S	13.21	13.72	0.520	0.540
T	15.75	16.26	0.620	0.640
U	1.65	2.03	0.065	0.080
W	-	0.10	-	0.004

Die konvexe Form des Substrates ist typ. < 0.04 mm über der Kunststoffoberfläche der Bauteilunterseite
 The convex bow of substrate is typ. < 0.04 mm over plastic surface level of device bottom side

Die Gehäuseabmessungen entsprechen dem Typ TO-247 AD gemäß JEDEC außer Schraubloch und L_{max} .
 This drawing will meet all dimensions requirement of JEDEC outline TO-247 AD except screw hole and except L_{max} .

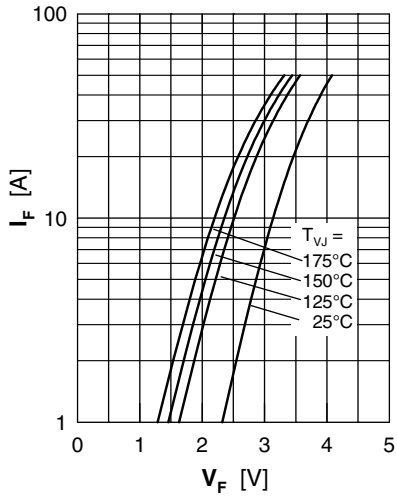

Fig. 1 Maximum forward voltage drop characteristics

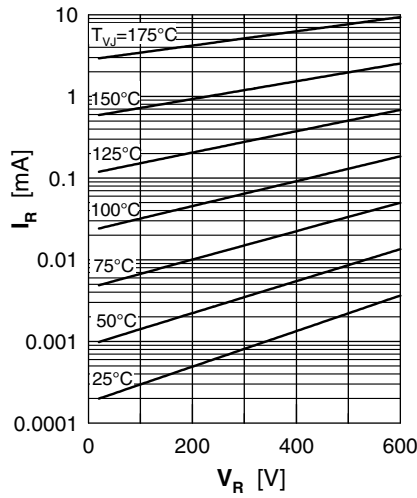

Fig. 2 Typ. reverse current I_R vs. reverse voltage V_R

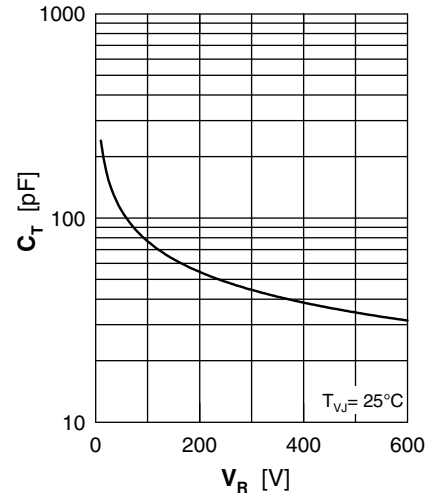

Fig. 3 Typ. junction capacitance C_T vs. reverse voltage V_R

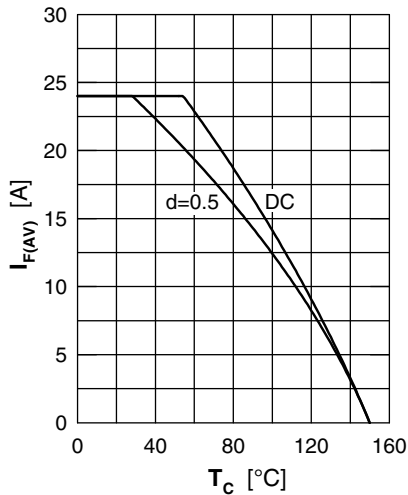

Fig. 4 Average forward current $I_{F(AV)}$ vs. case temperature T_C

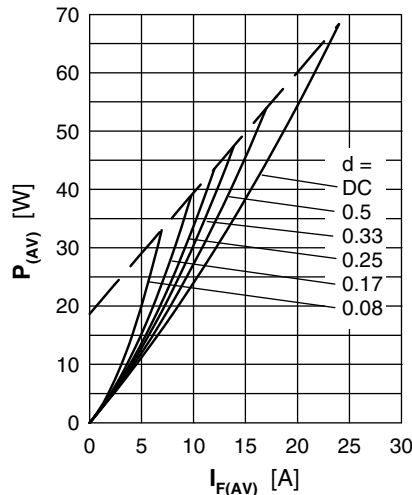

Fig. 5 Forward power loss characteristics

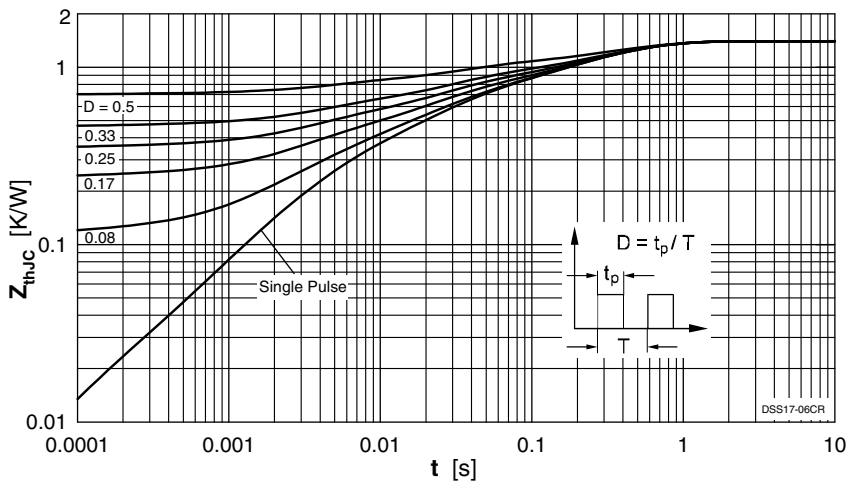

Fig. 6 Transient thermal impedance junction to case at various duty cycles

Note: All curves are per diode