



Precision SMBus-Compatible Remote/Local Temperature Sensors with Overtemperature Alarms

General Description

The MAX6648/MAX6692 are precise, two-channel digital temperature sensors. They accurately measure the temperature of their own die and a remote PN junction, and report the temperature in digital form using a 2-wire serial interface. The remote PN junction is typically the emitter-base junction of a common-collector PNP on a CPU, FPGA, or ASIC.

The 2-wire serial interface accepts standard System Management Bus (SMBus)[™] write byte, read byte, send byte, and receive byte commands to read the temperature data and to program the alarm thresholds. To enhance system reliability, the MAX6648/MAX6692 include an SMBus timeout. A fault queue prevents the $\overline{\text{ALERT}}$ and $\overline{\text{OVERT}}$ outputs from setting until a fault has been detected one, two, or three consecutive times (programmable).

The MAX6648/MAX6692 provide two system alarms: $\overline{\text{ALERT}}$ and $\overline{\text{OVERT}}$. $\overline{\text{ALERT}}$ asserts when any of four temperature conditions are violated: local overtemperature, remote overtemperature, local undertemperature, or remote undertemperature. $\overline{\text{OVERT}}$ asserts when the temperature rises above the value in either of the two $\overline{\text{OVERT}}$ limit registers. The $\overline{\text{OVERT}}$ output can be used to activate a cooling fan, or to trigger a system shutdown.

Measurements can be done autonomously, with the conversion rate programmed by the user, or in a single-shot mode. The adjustable conversion rate allows the user to optimize supply current and temperature update rate to match system needs.

Remote accuracy is $\pm 0.8^\circ\text{C}$ maximum error between $+25^\circ\text{C}$ and $+125^\circ\text{C}$ with no calibration needed. The MAX6648/MAX6692 operate from -55°C to $+125^\circ\text{C}$, and measure temperatures between 0°C and $+125^\circ\text{C}$. The MAX6648 is available in an 8-pin μMAX° package, and the MAX6692 is available in 8-pin μMAX and SO packages.

Applications

- Desktop Computers
- Notebook Computers
- Servers
- Thin Clients
- Workstations
- Test and Measurement
- Multichip Modules

SMBus is a trademark of Intel Corp.

μMAX is a registered trademark of Maxim Integrated Products, Inc.



Maxim Integrated Products 1

For pricing, delivery, and ordering information, please contact Maxim Direct at 1-888-629-4642, or visit Maxim's website at www.maxim-ic.com.

Features

- ◆ Dual Channel Measures Remote and Local Temperature
- ◆ $+0.125^\circ\text{C}$ Resolution
- ◆ High Accuracy $\pm 0.8^\circ\text{C}$ (max) from $+25^\circ\text{C}$ to $+125^\circ\text{C}$ (Remote), and $\pm 2^\circ\text{C}$ (max) from $+60^\circ\text{C}$ to $+100^\circ\text{C}$ (Local)
- ◆ Two Alarm Outputs: $\overline{\text{ALERT}}$ and $\overline{\text{OVERT}}$
- ◆ Two Default $\overline{\text{OVERT}}$ Thresholds Available
MAX6648: $+110^\circ\text{C}$
MAX6692: $+85^\circ\text{C}$
- ◆ Programmable Conversion Rate
- ◆ SMBus-Compatible Interface
- ◆ SMBus Timeout
- ◆ Programmable Under/Overtemperature Alarm Thresholds
- ◆ Compatible with 65nm Process Technology (Y Versions)

Ordering Information

PART	PIN-PACKAGE	MEASURED TEMP RANGE	PKG CODE
MAX6648MUA	8 μMAX	0°C to $+125^\circ\text{C}$	U8-1
MAX6648YMUA	8 μMAX	0°C to $+125^\circ\text{C}$	U8-1
MAX6692MUA	8 μMAX	0°C to $+125^\circ\text{C}$	U8-1
MAX6692MSA	8 SO	0°C to $+125^\circ\text{C}$	S8-4
MAX6692YMUA	8 μMAX	0°C to $+125^\circ\text{C}$	U8-1
MAX6692YMSA	8 SO	0°C to $+125^\circ\text{C}$	S8-4

Note: All devices operate over the -55°C to $+125^\circ\text{C}$ temperature range.

Typical Operating Circuit

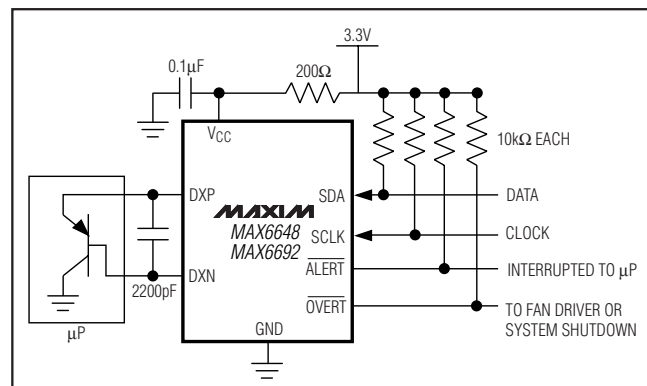

Pin Configuration and Functional Diagram appear at end of data sheet.

Precision SMBus-Compatible Remote/Local Temperature Sensors with Overtemperature Alarms

ABSOLUTE MAXIMUM RATINGS

(All voltages referenced to GND.)

V _{CC}	-0.3V to +6V
DXP.....	-0.3V to (V _{CC} + 0.3V)
DXN.....	-0.3V to +0.8V
SCLK, SDA, ALERT, OVERT.....	-0.3V to +6V
SDA, ALERT, OVERT Current.....	-1mA to +50mA
DXN Current.....	±1mA
Continuous Power Dissipation (T _A = +70°C)	
8-Pin μMAX (derate 5.9mW/°C above +70°C).....	471mW
8-Pin SO (derate 5.9mW/°C above +70°C).....	471mW

ESD Protection (all pins, Human Body Model).....	±2000V
Junction Temperature.....	+150°C
Operating Temperature Range.....	-55°C to +125°C
Storage Temperature Range.....	-65°C to +150°C
Lead Temperature (soldering, 10s).....	+300°C

Stresses beyond those listed under "Absolute Maximum Ratings" may cause permanent damage to the device. These are stress ratings only, and functional operation of the device at these or any other conditions beyond those indicated in the operational sections of the specifications is not implied. Exposure to absolute maximum rating conditions for extended periods may affect device reliability.

ELECTRICAL CHARACTERISTICS

(V_{CC} = 3.0V to 5.5V, T_A = -55°C to +125°C, unless otherwise specified. Typical values are at V_{CC} = 3.3V and T_A = +85°C.) (Note 1)

PARAMETER	SYMBOL	CONDITIONS		MIN	TYP	MAX	UNITS	
Supply Voltage	V _{CC}			3.0		5.5	V	
Temperature Resolution				0.125			°C	
					10		Bits	
Remote Temperature Error		V _{CC} = 3.3V, T _A = +85°C	T _{RJ} = +25°C to +125°C	-0.8		+0.8	°C	
			V _{CC} = 3.3V, +60°C ≤ T _A ≤ +100°C	T _{RJ} = +60°C to +100°C	-1.0			+1.0
				T _{RJ} = 0°C to +125°C	-1.6			+1.6
			V _{CC} = 3.3V, +0°C ≤ T _A ≤ +100°C	T _{RJ} = 0°C to +125°C	-3.0			+3.0
Local Temperature Error		V _{CC} = 3.3V	T _A = +60°C to +100°C	-2.0		+2.0	°C	
			T _A = 0°C to +125°C	-3.0		+3.0		
Local Temperature Error (MAX6648Y/MAX6692Y)		V _{CC} = 3.3V	T _A = +60°C to +100°C		-4.0		°C	
			T _A = 0°C to +125°C		-4.4			
Supply Sensitivity of Temperature Error					±0.2		°C/V	
Undervoltage Lockout (UVLO) Threshold	UVLO	Falling edge of V _{CC} disables ADC		2.4	2.7	2.95	V	
UVLO Hysteresis					90		mV	
Power-On-Reset (POR) Threshold		V _{CC} falling edge			2.0		V	
POR Threshold Hysteresis					90		mV	
Standby Supply Current		SMBus static			3.5	12	μA	
Operating Current		During conversion			0.45	0.8	mA	
Average Operating Current		0.25 conversions per second			40	80	μA	
		2 conversions per second			250	400		
Conversion Time	t _{CONV}	From stop bit to conversion completion		95	125	156	ms	
Conversion Time Error				-25		+25	%	
DXP and DXN Leakage Current		Standby mode				100	nA	

Precision SMBus-Compatible Remote/Local Temperature Sensors with Overtemperature Alarms

ELECTRICAL CHARACTERISTICS (continued)

(V_{CC} = 3.0V to 5.5V, T_A = -55°C to +125°C, unless otherwise specified. Typical values are at V_{CC} = 3.3V and T_A = +85°C.) (Note 1)

PARAMETER	SYMBOL	CONDITIONS	MIN	TYP	MAX	UNITS
Remote-Diode Source Current	I _{RJ}	High level	80	100	120	μA
		Low level	8	10	12	
ALERT, OVERT						
Output Low Voltage		I _{SINK} = 1mA			0.4	V
		I _{SINK} = 4mA			0.6	
Output High Leakage Current		V _{OH} = 5.5V			1	μA
SMBus-COMPATIBLE INTERFACE (SCLK AND SDA)						
Logic Input Low Voltage	V _{IL}				0.8	V
Logic Input High Voltage	V _{IH}	V _{CC} = 3.0V	2.2			V
		V _{CC} = 5.5V	2.6			
Input Leakage Current	I _{LEAK}	V _{IN} = GND or V _{CC}	-1		+1	μA
Output Low-Sink Current	I _{SINK}	V _{OL} = 0.6V	6			mA
Input Capacitance	C _{IN}			5		pF
SMBus-COMPATIBLE TIMING (Note 2)						
Serial Clock Frequency	f _{SCLK}	(Note 3)			100	kHz
Bus Free Time Between STOP and START Condition	t _{BUF}		4.7			μs
START Condition Setup Time			4.7			μs
Repeat START Condition Setup Time	t _{SU:STA}	90% to 90%	50			ns
START Condition Hold Time	t _{HD:STA}	10% of SDA to 90% of SCLK	4			μs
STOP Condition Setup Time	t _{SU:STO}	90% of SCLK to 90% of SDA	4			μs
Clock Low Period	t _{LOW}	10% to 10%	4.7			μs
Clock High Period	t _{HIGH}	90% to 90%	4			μs
Data Setup Time	t _{HD:DAT}	(Note 4)	250			μs
Receive SCLK/SDA Rise Time	t _R				1	μs
Receive SCLK/SDA Fall Time	t _F				300	ns
Pulse Width of Spike Suppressed	t _{SP}		0		50	ns
SMBus Timeout	t _{TIMEOUT}	SDA low period for interface reset	25	37	55	ms

Note 1: All parameters tested at a single temperature. Specifications over temperature are guaranteed by design.

Note 2: Timing specifications guaranteed by design.

Note 3: The serial interface resets when SCLK is low for more than t_{TIMEOUT}.

Note 4: A transition must internally provide at least a hold time to bridge the undefined region (300ns max) of SCLK's falling edge.

Precision SMBus-Compatible Remote/Local Temperature Sensors with Overtemperature Alarms

Typical Operating Characteristics

($V_{CC} = 3.3V$, $T_A = +25^{\circ}C$, unless otherwise noted.)

STANDBY SUPPLY CURRENT vs. SUPPLY VOLTAGE

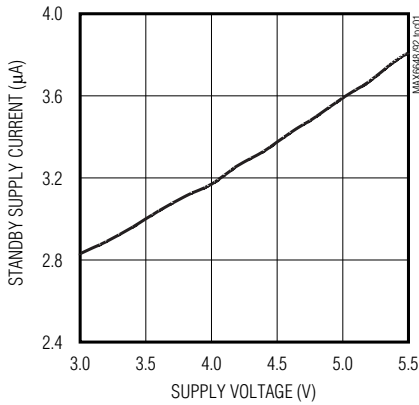

OPERATING SUPPLY CURRENT vs. CONVERSION RATE

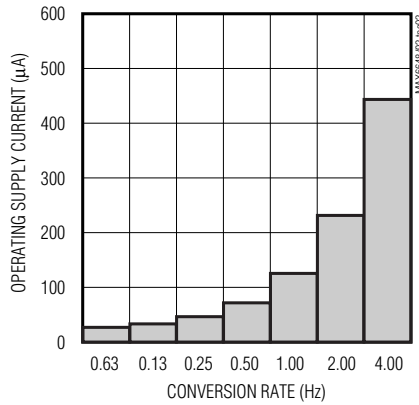

REMOTE TEMPERATURE ERROR vs. REMOTE-DIODE TEMPERATURE

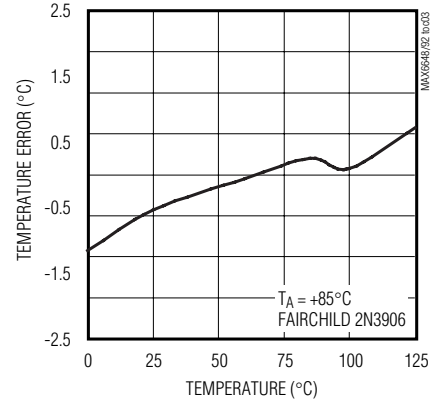

LOCAL TEMPERATURE ERROR vs. DIE TEMPERATURE

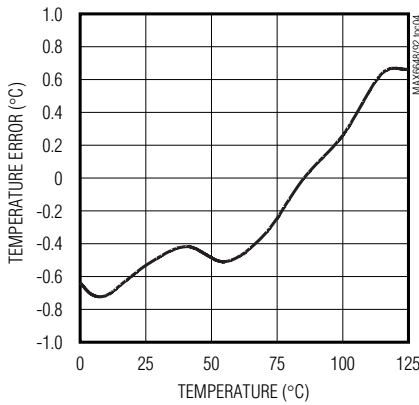

TEMPERATURE ERROR vs. POWER-SUPPLY NOISE FREQUENCY

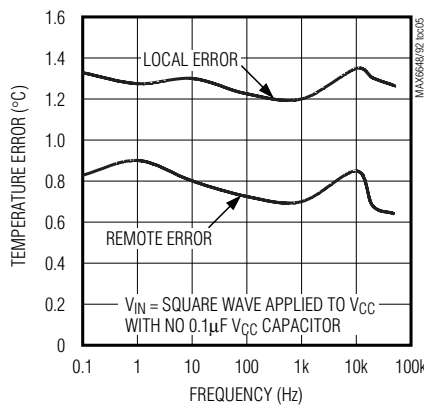

TEMPERATURE ERROR vs. COMMON-MODE NOISE FREQUENCY

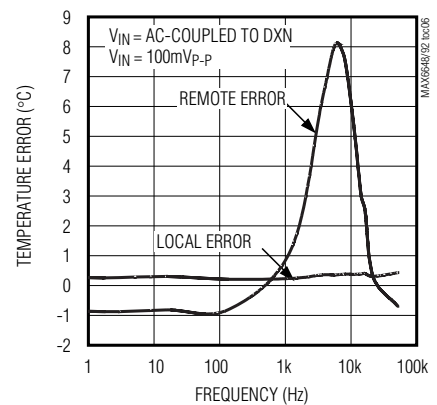

TEMPERATURE ERROR vs. DIFFERENTIAL-MODE NOISE FREQUENCY

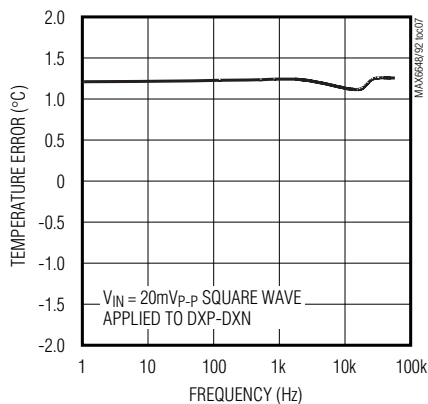

TEMPERATURE ERROR vs. DXP-DXN CAPACITANCE

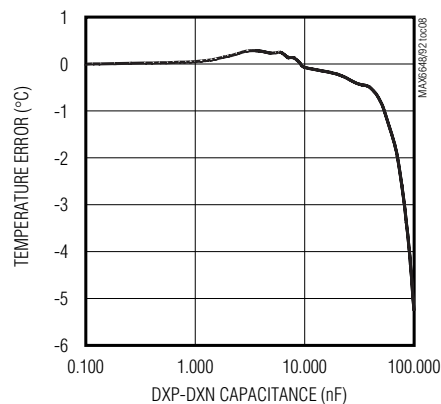

Precision SMBus-Compatible Remote/Local Temperature Sensors with Overtemperature Alarms

Pin Description

PIN	NAME	FUNCTION
1	V _{CC}	Supply Voltage Input, 3V to 5.5V. Bypass V _{CC} to GND with a 0.1μF capacitor. A 200Ω series resistor is recommended but not required for additional noise filtering.
2	DXP	Combined Remote-Diode Current Source and A/D Positive Input for Remote-Diode Channel. DO NOT LEAVE DXP FLOATING ; tie DXP to DXN if no remote diode is used. Place a 2200pF capacitor between DXP and DXN for noise filtering.
3	DXN	Combined Remote-Diode Current Sink and A/D Negative Input. DXN is internally biased to one diode drop above ground.
4	$\overline{\text{OVERT}}$	Overtemperature Alert/Interrupt Output, Open Drain. $\overline{\text{OVERT}}$ is logic low when the temperature is above the software-programmed threshold.
5	GND	Ground
6	$\overline{\text{ALERT}}$	SMBus Alert (Interrupt) Output, Open Drain. $\overline{\text{ALERT}}$ asserts when temperature exceeds user-set limits (high or low temperature). $\overline{\text{ALERT}}$ stays asserted until acknowledged by either reading the status register or by successfully responding to an alert response address, provided that the fault condition no longer exists. See the <i>$\overline{\text{ALERT}}$ Interrupts</i> section.
7	SDA	SMBus Serial-Data Input/Output, Open Drain
8	SCLK	SMBus Serial-Clock Input

Detailed Description

The MAX6648/MAX6692 are temperature sensors designed to work in conjunction with a microprocessor or other intelligence in thermostatic, process-control, or monitoring applications. Communication with the MAX6648/MAX6692 occurs through the SMBus-compatible serial interface and dedicated alert pins. $\overline{\text{ALERT}}$ asserts if the measured local or remote temperature is greater than the software-programmed $\overline{\text{ALERT}}$ high limit or less than the $\overline{\text{ALERT}}$ low limit. $\overline{\text{ALERT}}$ also asserts if the remote-sensing diode pins are shorted or unconnected. The overtemperature alarm, $\overline{\text{OVERT}}$, asserts if the software-programmed $\overline{\text{OVERT}}$ limit is exceeded. $\overline{\text{OVERT}}$ can be connected to fans, a system shutdown, a clock throttle control, or other thermal-management circuitry.

The MAX6648/MAX6692 convert temperatures to digital data either at a programmed rate or in single conversions. Temperature data is represented as 10 bits plus sign, with the LSB equal to 0.125°C. The “main” temperature data registers (at addresses 00h and 01h) are 8-bit registers that represent the data as 7 bits with the final MSB indicating the diode fault status (Table 1). The remaining 3 bits of temperature data are available in the “extended” registers at addresses 11h and 10h (Table 2).

ADC and Multiplexer

The averaging ADC integrates over a 60ms period (each channel, typically), with excellent noise rejection. The multiplexer automatically steers bias currents through the remote and local diodes. The ADC and associated circuitry measure each diode’s forward voltage and compute the temperature based on this voltage. Both channels are automatically converted once the conversion process has started, either in free-running or single-shot mode. If one of the two channels is not used, the device still performs both measurements, and the user can ignore the results of the unused chan-

Table 1. Main Temperature Data Register Format (00h, 01h)

TEMP (°C)	DIGITAL OUTPUT
130	0 111 1111
127	0 111 1111
126	0 111 1111
25	0 001 1001
0	0 000 0000
<0	0 000 0000
-1	0 000 0000
-25	0 000 0000
Diode fault (short or open)	1 000 0000

Precision SMBus-Compatible Remote/Local Temperature Sensors with Overtemperature Alarms

nel. If the remote-diode channel is unused, connect DXP to DXN rather than leaving the pins open.

The DXN input is biased to one V_{BE} above ground by an internal diode to prepare the ADC inputs for a differential measurement. The worst-case DXP-DXN differential input voltage range is 0.25V to 0.95V. Excess resistance in series with the remote diode causes +0.5°C (typ) error per ohm.

A/D Conversion Sequence

A conversion sequence consists of a local temperature measurement and a remote temperature measurement. Each time a conversion begins, whether initiated automatically in the free-running autonomous mode ($\overline{RUN} = 0$) or by writing a one-shot command, both channels are converted, and the results of both measurements are available after the end of a conversion. A BUSY status bit in the status byte indicates that the device is performing a new conversion. The results of the previous conversion are always available, even if the ADC is busy.

Low-Power Standby Mode

Standby mode reduces the supply current to less than 10 μ A by disabling the ADC and timing circuitry. Enter standby mode by setting the \overline{RUN} bit to 1 in the configuration byte register (Table 6). All data is retained in memory, and the SMBus interface is active and listening for SMBus commands. Standby mode is not a shutdown mode. With activity on the SMBus, the device draws more supply current (see *Typical Operating Characteristics*). In standby mode, the MAX6648/MAX6692 can be forced to perform A/D conversions through the one-shot command, regardless of the \overline{RUN} bit status.

If a standby command is received while a conversion is in progress, the conversion cycle is truncated, and the data from that conversion is not latched into a temperature register. The previous data is not changed and remains available.

Supply-current drain during the 125ms conversion period is 500 μ A (typ). Slowing down the conversion rate reduces the average supply current (see *Typical Operating Characteristics*). Between conversions, the conversion rate timer consumes about 25 μ A of supply current. In standby mode, supply current drops to about 3 μ A.

SMBus Digital Interface

From a software perspective, the MAX6648/MAX6692 appear as a set of byte-wide registers that contain temperature data, alarm threshold values, and control bits. A standard SMBus-compatible 2-wire serial interface is used to read temperature data and write control bits and alarm threshold data. These devices respond to the same SMBus slave address for access to all functions.

The MAX6648/MAX6692 employ four standard SMBus protocols: write byte, read byte, send byte, and receive byte (Figures 1, 2, and 3). The shorter receive byte protocol allows quicker transfers, provided that the correct data register was previously selected by a read byte instruction. Use caution when using the shorter protocols in multimaster systems, as a second master could overwrite the command byte without informing the first master.

Temperature data can be read from the read internal temperature (00h) and read external temperature (01h) registers. The temperature data format for these registers is 7 bits plus 1 bit, indicating the diode fault status for each channel, with the LSB representing 1°C (Table 1). The MSB is transmitted first.

An additional 3 bits can be read from the read external extended temperature register (10h), which extends the data to 10 bits plus sign and the resolution to 0.125°C per LSB (Table 2). An additional 3 bits can be read from the read internal extended temperature register (11h), which extends the data to 10 bits (plus 1 bit indicating the diode fault status) and the resolution to 0.125°C per LSB (Table 2).

When a conversion is complete, the main temperature register and the extended temperature register are updated simultaneously. Ensure that no conversions are completed between reading the main register and the extended register, so that both registers contain the result of the same conversion.

To ensure valid extended data, read extended resolution temperature data using one of the following approaches:

- 1) Put the MAX6648/MAX6692 into standby mode by setting bit 6 of the configuration register to 1. Initiate a one-shot conversion using command byte 0Fh. When this conversion is complete, read the contents of the temperature data registers.

Table 2. Extended Resolution Temperature Register Data Format (10h, 11h)

FRACTIONAL TEMP (°C)	DIGITAL OUTPUT
0.000	000X XXXX
0.125	001X XXXX
0.250	010X XXXX
0.375	011X XXXX
0.500	100X XXXX
0.625	101X XXXX
0.750	110X XXXX
0.875	111X XXXX

Precision SMBus-Compatible Remote/Local Temperature Sensors with Overtemperature Alarms

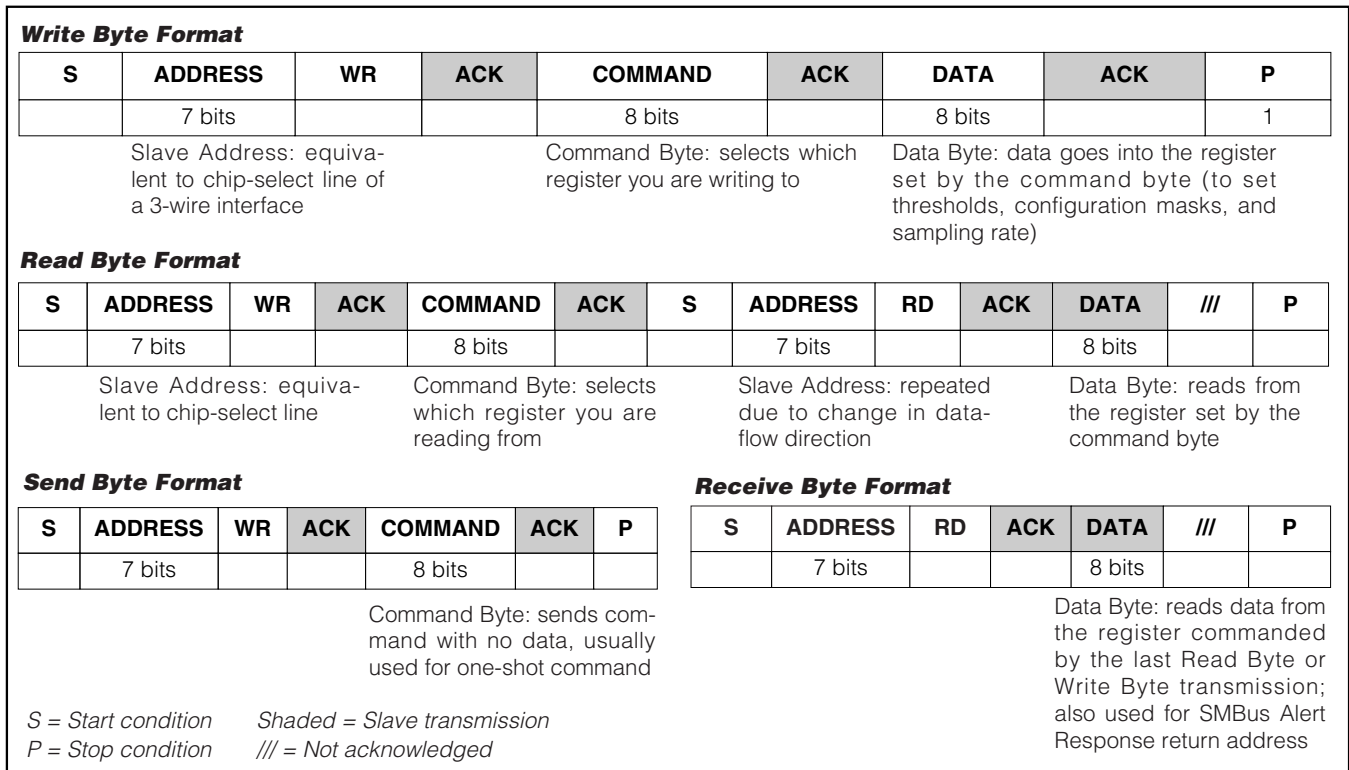

Figure 1. SMBus Protocols

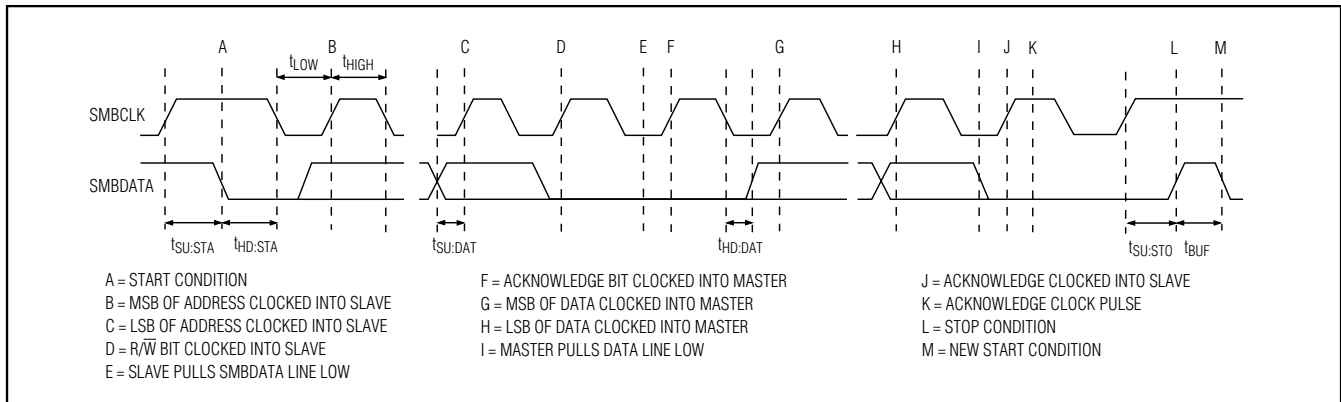

Figure 2. SMBus Write Timing Diagram

2) If the MAX6648/MAX6692 are in run mode, read the status byte. If the BUSY bit indicates that a conversion is in progress, wait until the conversion is complete (BUSY bit set to zero) before reading the temperature data. Following a conversion completion, immediately

read the contents of the temperature data registers. If no conversion is in progress, the data can be read within a few microseconds, which is a sufficiently short period of time to ensure that a new conversion cannot be completed until after the data has been read.

Precision SMBus-Compatible Remote/Local Temperature Sensors with Overtemperature Alarms

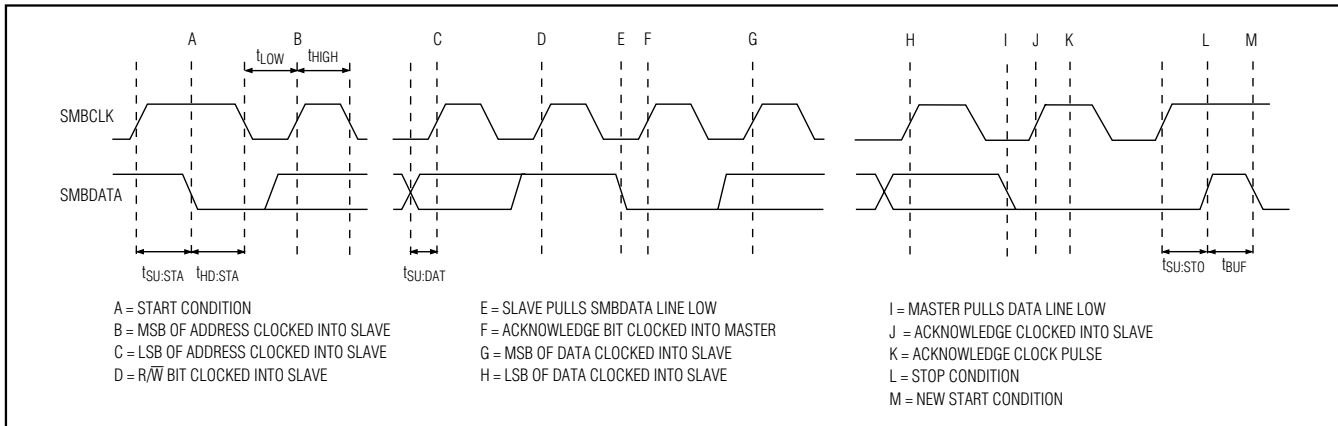

Figure 3. SMBus Read Timing Diagram

Alarm Threshold Registers

Four registers store $\overline{\text{ALERT}}$ threshold values—one high-temperature (T_{HIGH}) and one low-temperature (T_{LOW}) register each for the local and remote channels. If either measured temperature equals or exceeds the corresponding $\overline{\text{ALERT}}$ threshold value, the $\overline{\text{ALERT}}$ interrupt asserts.

The power-on-reset (POR) state of both $\overline{\text{ALERT}}$ T_{HIGH} registers is full scale (0101 0101, or +85°C). The POR state of both T_{LOW} registers is 0000 0000, or 0°C.

Two additional registers store remote and local alarm threshold data corresponding to the $\overline{\text{OVERT}}$ output. The values stored in these registers are high-temperature thresholds. If either of the measured temperatures equals or exceeds the corresponding alarm threshold value, an $\overline{\text{OVERT}}$ output asserts. The POR state of the $\overline{\text{OVERT}}$ threshold is 0110 1110 or +110°C for the MAX6648, and 0101 0101 or +85°C for the MAX6692.

Diode Fault Alarm

A continuity fault detector at DXP detects an open circuit between DXP and DXN, or a DXP short to VCC, GND, or DXN. If an open or short circuit exists, the external temperature register is loaded with 1000 0000. If the fault is an open-circuit fault bit 2 (OPEN) of the status byte, it is set to 1 and the $\overline{\text{ALERT}}$ condition is activated at the end of the conversion. Immediately after POR, the status register indicates that no fault is present. If a fault is present upon power-up, the fault is not indicated until the end of the first conversion.

$\overline{\text{ALERT}}$ Interrupts

The $\overline{\text{ALERT}}$ interrupt occurs when the internal or external temperature reading exceeds a high- or low-temperature limit (user programmed) or when the remote diode is disconnected (for continuity fault detection).

The $\overline{\text{ALERT}}$ interrupt output signal is latched and can be cleared only by either reading the status register or by successfully responding to an alert response address. In both cases, the alert is cleared only if the fault condition no longer exists. Asserting $\overline{\text{ALERT}}$ does not halt automatic conversion. The $\overline{\text{ALERT}}$ output pin is open drain, allowing multiple devices to share a common interrupt line.

The MAX6648/MAX6692 respond to the SMBus alert response address, an interrupt pointer return-address feature (see the *Alert Response Address* section). Prior to taking corrective action, always check to ensure that an interrupt is valid by reading the current temperature.

Fault Queue Register

In some systems, it may be desirable to ignore a single temperature measurement that falls outside the $\overline{\text{ALERT}}$ limits. Bits 2 and 3 of the fault queue register (address 22h) determine the number of consecutive temperature faults necessary to set $\overline{\text{ALERT}}$ (see Tables 3 and 4).

Alert Response Address

The SMBus alert response interrupt pointer provides quick fault identification for simple slave devices that lack the complex, expensive logic needed to be a bus master. Upon receiving an $\overline{\text{ALERT}}$ interrupt signal, the host master can broadcast a receive byte transmission to the alert response slave address (0001 100). Following such a broadcast, any slave device that generated an interrupt attempts to identify itself by putting its own address on the bus.

The alert response can activate several different slave devices simultaneously, similar to the I²C general call. If more than one slave attempts to respond, bus arbitration rules apply, and the device with the lower address code wins. The losing device does not generate an

Precision SMBus-Compatible Remote/Local Temperature Sensors with Overtemperature Alarms

Table 3. Fault Queue Register Bit Definition (22h)

BIT	NAME	POR STATE	FUNCTION
7	RFU	1	Reserved. Always write 1 to this bit.
6 to 3	RFU	0	Reserved. Always write zero to this bit.
2	FQ1	0	Fault queue-length control bit (see Table 4).
1	FQ0	0	Fault queue-length control bit (see Table 4).
0	RFU	0	Reserved. Always write zero to this bit.

acknowledge and continues to hold the $\overline{\text{ALERT}}$ line low until cleared. (The conditions for clearing an $\overline{\text{ALERT}}$ vary, depending on the type of slave device). Successful completion of the read alert response protocol clears the interrupt latch, provided the condition that caused the alert no longer exists.

$\overline{\text{OVERT}}$ Overtemperature Alarm/Warning Outputs

$\overline{\text{OVERT}}$ asserts when the temperature rises to a value stored in one of the $\overline{\text{OVERT}}$ limit registers (19h, 20h). It deasserts when the temperature drops below the stored limit, minus hysteresis. $\overline{\text{OVERT}}$ can be used to activate a cooling fan, send a warning, invoke clock throttling, or trigger a system shutdown to prevent component damage.

Command Byte Functions

The 8-bit command byte register (Table 5) is the master index that points to the various other registers within the MAX6648/MAX6692. The register's POR state is 0000 0000, so a receive byte transmission (a protocol that lacks the command byte) that occurs immediately after POR, returns the current local temperature data.

The MAX6648/MAX6692 incorporate collision avoidance so that completely asynchronous operation is allowed between SMBus operations and temperature conversions.

One-Shot

The one-shot command immediately forces a new conversion cycle to begin. If the one-shot command is received while the MAX6648/MAX6692 are in standby mode ($\overline{\text{RUN}}$ bit = 1), a new conversion begins, after which the device returns to standby mode. If a one-shot

Table 4. Fault Queue Length Bit Definition

FQ1	FQ0	FAULT QUEUE LENGTH (SAMPLES)
0	0	1
0	1	2
1	1	3
1	0	—

conversion is in progress when a one-shot command is received, the command is ignored. If a one-shot command is received in autonomous mode ($\overline{\text{RUN}}$ bit = 0) between conversions, a new conversion begins, the conversion rate timer is reset, and the next automatic conversion takes place after a full delay elapses.

Configuration Byte Functions

The configuration byte register (Table 6) is a read-write register with several functions. Bit 7 is used to mask (disable) interrupts. Bit 6 puts the MAX6648/MAX6692 into standby mode (STOP) or autonomous (RUN) mode.

Status Byte Functions

The status byte register (Table 7) indicates which (if any) temperature thresholds have been exceeded. This byte also indicates whether the ADC is converting and whether there is an open-circuit fault detected in the external sense junction. After POR, the normal state of all flag bits is zero, assuming no alarm conditions are present. The status byte is cleared by any successful read of the status byte, after a conversion is complete and the fault no longer exists. Note that the $\overline{\text{ALERT}}$ interrupt latch is not automatically cleared when the status flag bit indicating the $\overline{\text{ALERT}}$ is cleared. The fault condition must be eliminated before the $\overline{\text{ALERT}}$ output can be cleared.

When autoconverting, if the T_{HIGH} and T_{LOW} limits are close together, it is possible for both high-temp and low-temp status bits to be set, depending on the amount of time between status read operations (especially when converting at the fastest rate). In these circumstances, it is best not to rely on the status bits to indicate reversals in long-term temperature changes. Instead use a current temperature reading to establish the trend direction.

Conversion Rate Byte

The conversion rate register (Table 8) programs the time interval between conversions in free-running autonomous mode ($\overline{\text{RUN}}$ = 0). This variable rate control can be used to reduce the supply current in portable-equipment applications. The conversion rate byte's POR state is 07h or 4Hz. The MAX6648/MAX6692 look

Precision SMBus-Compatible Remote/Local Temperature Sensors with Overtemperature Alarms

Table 5. Command-Byte Bit Assignments

REGISTER	ADDRESS	POR STATE		FUNCTION
RLTS	00h	0000 0000	0°C	Read local (internal) temperature
RRTE	01h	0000 0000	0°C	Read remote (external) temperature
RSL	02h	N/A	—	Read status byte
RCL	03h	0000 0000	—	Read configuration byte
RCRA	04h	0000 0111	—	Read conversion rate byte
RLHN	05h	0101 0101	+85°C	Read local (internal) $\overline{\text{ALERT}}$ high limit
RLLI	06h	0000 0000	0°C	Read local (internal) $\overline{\text{ALERT}}$ low limit
RRHI	07h	0101 0101	+85°C	Read remote (external) $\overline{\text{ALERT}}$ high limit
RRLS	08h	0000 0000	0°C	Read remote (external) $\overline{\text{ALERT}}$ low limit
WCA	09h	N/A	—	Write configuration byte
WCRW	0Ah	N/A	—	Write conversion rate byte
WLHO	0Bh	N/A	—	Write local (internal) $\overline{\text{ALERT}}$ high limit
WLLM	0Ch	N/A	—	Write local (internal) $\overline{\text{ALERT}}$ low limit
WRHA	0Dh	N/A	—	Write remote (external) $\overline{\text{ALERT}}$ high limit
WRLN	0Eh	N/A	—	Write remote (external) $\overline{\text{ALERT}}$ low limit
OSHT	0Fh	N/A	—	One-shot
REET	10h	0000 0000	0°C	Read remote (external) extended temperature
RIET	11h	0000 0000	0°C	Read local (internal) extended temperature
RWOE	19h	0110 1110	+110°C	Read/write remote (external) $\overline{\text{OVERT}}$ limit (MAX6648)
		0101 0101	+85°C	Read/write remote (external) $\overline{\text{OVERT}}$ limit (MAX6692)
RWOI	20h	0101 0101	+85°C	Read/write local (internal) $\overline{\text{OVERT}}$ limit
HYS	21h	0000 1010	10°C	Overtemperature hysteresis
QUEUE	22h	1000 0000	—	Fault queue
—	FEh	0100 1101	—	Read manufacture ID
—	FFh	0101 1001	—	Read revision ID

Table 6. Configuration-Byte Bit Assignments (03h)

BIT	NAME	POR STATE	FUNCTION
7 (MSB)	MASK	0	Masks $\overline{\text{ALERT}}$ interrupts when set to 1.
6	$\overline{\text{RUN}}$	0	Standby mode control bit; if set to 1, standby mode is initiated.
5 to 0	RFU	0	Reserved.

only at the 3 LSBs of this register, so the upper 5 bits are don't care bits, which should be set to zero. The conversion rate tolerance is $\pm 25\%$ at any rate setting.

Valid A/D conversion results for both channels are available one total conversion time (125ms nominal, 156ms maximum) after initiating a conversion, whether conversion is initiated through the $\overline{\text{RUN}}$ bit, one-shot command, or initial power-up. Changing the conversion rate can also affect the delay until new results are available.

Slave Addresses

The MAX6648/MAX6692 have a fixed address of 1001 100. The MAX6648/MAX6692 also respond to the SMBus alert response slave address (see the *Alert Response Address* section).

POR and UVLO

To prevent ambiguous power-supply conditions from corrupting the data in memory and causing erratic behavior, a POR voltage detector monitors VCC and

Precision SMBus-Compatible Remote/Local Temperature Sensors with Overtemperature Alarms

Table 7. Status Register Bit Assignments (02h)

BIT	NAME	POR STATE	FUNCTION
7 (MSB)	BUSY	0	A/D is busy converting when 1.
6	LHIGH	0	Local (internal) high-temperature alarm has tripped when 1; cleared by POR or readout of the status byte if the fault condition no longer exists.
5	LLOW	0	Local (internal) low-temperature alarm has tripped when 1; cleared by POR or readout of the status byte if the fault condition no longer exists.
4	RHIGH	0	Remote (external) high-temperature alarm has tripped when 1; cleared by POR or readout of the status byte if the fault condition no longer exists.
3	RLOW	0	Remote (external) low-temperature alarm has tripped when 1; cleared by POR or readout of the status byte if the fault condition no longer exists.
2	FAULT	0	A 1 indicates DXN and DXP are either shorted or open; cleared by POR or readout of the status byte if the fault condition no longer exists.
1	EOT	0	A 1 indicates the remote (external) junction temperature exceeds the external $\overline{\text{OVERT}}$ threshold.
0	IOT	0	A 1 indicates the local (internal) junction temperature exceeds the internal $\overline{\text{OVERT}}$ threshold.

clears the memory if V_{CC} falls below 2.0V (typ). When power is first applied and V_{CC} rises above 2.0V (typ), the logic blocks begin operating, although reads and writes at V_{CC} levels below 3V are not recommended. A second V_{CC} comparator, the ADC UVLO comparator prevents the ADC from converting until there is sufficient headroom ($V_{CC} = 2.8V$ typ).

Power-Up Defaults

Power-up defaults include:

- Interrupt latch is cleared.
- ADC begins autoconverting at a 4Hz rate.
- Command byte is set to 00h to facilitate quick local temperature receive byte queries.
- Local (internal) T_{HIGH} limit set to +85°C.
- Local (internal) T_{LOW} limit set to 0°C.
- Remote (external) T_{HIGH} limit set to +85°C.
- Remote (external) T_{LOW} limit set to 0°C.
- $\overline{\text{OVERT}}$ internal limit is set to +85°C; every external limit is set to +110°C (MAX6648).
- $\overline{\text{OVERT}}$ limits are set to +85°C (MAX6692).

Applications Information

Table 8. Conversion-Rate Control Byte (04h)

DATA	CONVERSION RATE (Hz)
00h	0.0625
01h	0.125
02h	0.25
03h	0.5
04h	1
05h	2
06h	4
07h	4
08h-FFh	Reserved

Remote-Diode Selection

The MAX6648/MAX6692 can directly measure the die temperature of CPUs and other ICs that have on-board temperature-sensing diodes (see *Typical Operating Circuit*), or they can measure the temperature of a discrete diode-connected transistor.

Effect of Ideality Factor

The accuracy of the remote temperature measurements depends on the ideality factor (n) of the remote “diode”

Precision SMBus-Compatible Remote/Local Temperature Sensors with Overtemperature Alarms

(actually a transistor). The MAX6648/MAX6692 (not the MAX6648Y/MAX6692Y) are optimized for $n = 1.008$, which is the typical value for the Intel® Pentium® III and the AMD Athlon MP model 6. If a sense transistor with a different ideality factor is used, the output data is different. Fortunately, the difference is predictable.

Assume a remote-diode sensor designed for a nominal ideality factor n_{NOMINAL} is used to measure the temperature of a diode with a different ideality factor n_1 . The measured temperature T_M can be corrected using:

$$T_M = T_{\text{ACTUAL}} \left(\frac{n_1}{n_{\text{NOMINAL}}} \right)$$

where temperature is measured in Kelvin.

As mentioned above, the nominal ideality factor of the MAX6648/MAX6692 is 1.008. As an example, assume you want to use the MAX6648/MAX6692 with a CPU that has an ideality factor of 1.002.

If the diode has no series resistance, the measured data is related to the real temperature as follows:

$$T_{\text{ACTUAL}} = T_M \left(\frac{n_{\text{NOMINAL}}}{n_1} \right) = T_M \left(\frac{1.008}{1.002} \right) = T_M (1.00599)$$

For a real temperature of +85°C (358.15 K), the measured temperature is +82.91°C (356.02 K), which is an error of -2.13°C.

Effect of Series Resistance

Series resistance in a sense diode contributes additional errors. For nominal diode currents of 10μA and 100μA, change in the measured voltage is:

$$\Delta V_M = R_S (100\mu\text{A} - 10\mu\text{A}) = 90\mu\text{A} \times R_S$$

Since 1°C corresponds to 198.6μV, series resistance contributes a temperature offset of:

$$\frac{90\frac{\mu\text{V}}{\Omega}}{198.6\frac{\mu\text{V}}{\text{°C}}} = 0.453\frac{\text{°C}}{\Omega}$$

Assume that the diode being measured has a series

resistance of 3Ω. The series resistance contributes an offset of:

$$3\Omega \times 0.453\frac{\text{°C}}{\Omega} = 1.36\text{°C}$$

The effects of the ideality factor and series resistance are additive. If the diode has an ideality factor of 1.002 and series resistance of 3Ω, the total offset can be calculated by adding error due to series resistance with error due to ideality factor:

$$1.36\text{°C} - 2.13\text{°C} = -0.77\text{°C}$$

for a diode temperature of +85°C.

In this example, the effect of the series resistance and the ideality factor partially cancel each other.

For best accuracy, the discrete transistor should be a small-signal device with its collector and base connected together. Table 9 lists examples of discrete transistors that are appropriate for use with the MAX6648/MAX6692.

Table 9. Remote-Sensor Transistor Manufacturers

MANUFACTURER	MODEL NO.
Central Semiconductor (USA)	CMPT3904
Rohm Semiconductor (USA)	SST3904
Samsung (Korea)	KST3904-TF
Siemens (Germany)	SMBT3904

Note: Transistors must be diode connected (base shorted to collector).

The transistor must be a small-signal type with a relatively high forward voltage; otherwise, the A/D input voltage range can be violated. The forward voltage at the highest expected temperature must be greater than 0.25V at 10μA, and at the lowest expected temperature, the forward voltage must be less than 0.95V at 100μA. Large power transistors must not be used. Also, ensure that the base resistance is less than 100Ω. Tight specifications for forward current gain ($50 < \beta < 150$, for example) indicate that the manufacturer has good process controls and that the devices have consistent V_{BE} characteristics.

ADC Noise Filtering

The integrating ADC used has good noise rejection for low-frequency signals such as 60Hz/120Hz power-supply hum. In noisy environments, high-frequency noise reduction is needed for high-accuracy remote mea-

Intel and Pentium are registered trademarks of Intel Corp.

Precision SMBus-Compatible Remote/Local Temperature Sensors with Overtemperature Alarms

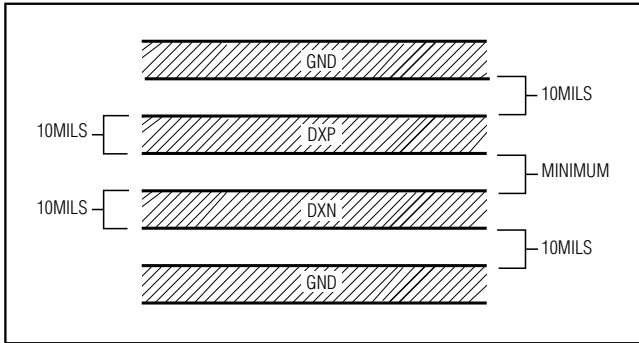

Figure 4. Recommended DXP-DXN PC Traces

surements. The noise can be reduced with careful printed-circuit board (PCB) layout and proper external noise filtering.

High-frequency EMI is best filtered at DXP and DXN with an external 2200pF capacitor. Larger capacitor values can be used for added filtering, but do not exceed 3300pF because larger values can introduce errors due to the rise time of the switched current source.

PCB Layout

Follow these guidelines to reduce the measurement error of the temperature sensors:

- 1) Place the MAX6648/MAX6692 as close as is practical to the remote diode. In noisy environments, such as a computer motherboard, this distance can be 4in to 8in (typ). This length can be increased if the worst noise sources are avoided. Noise sources include CRTs, clock generators, memory buses, and ISA/PCI buses.
- 2) Do not route the DXP-DXN lines next to the deflection coils of a CRT. Also, do not route the traces across fast digital signals, which can easily introduce 30°C error, even with good filtering.
- 3) Route the DXP and DXN traces in parallel and in close proximity to each other, away from any higher voltage traces, such as 12VDC. Leakage currents from PCB contamination must be dealt with carefully since a 20MΩ leakage path from DXP to ground causes about 1°C error. If high-voltage traces are unavoidable, connect guard traces to GND on either side of the DXP-DXN traces (Figure 4).
- 4) Route through as few vias and crossunders as possible to minimize copper/solder thermocouple effects.
- 5) When introducing a thermocouple, make sure that both the DXP and the DXN paths have matching

thermocouples. A copper-solder thermocouple exhibits 3μV/°C, and takes about 200μV of voltage error at DXP-DXN to cause a 1°C measurement error. Adding a few thermocouples causes a negligible error.

- 6) Use wide traces. Narrow traces are more inductive and tend to pick up radiated noise. The 10mil widths and spacing recommended in Figure 4 are not absolutely necessary, as they offer only a minor improvement in leakage and noise over narrow traces. Use wider traces when practical.
- 7) Add a 200Ω resistor in series with VCC for best noise filtering (see *Typical Operating Circuit*).
- 8) Copper cannot be used as an EMI shield; only ferrous materials such as steel work well. Placing a copper ground plane between the DXP-DXN traces and traces carrying high-frequency noise signals does not help reduce EMI.

Twisted-Pair and Shielded Cables

Use a twisted-pair cable to connect the remote sensor for remote-sensor distance longer than 8in, or in very noisy environments. Twisted-pair cable lengths can be between 6ft and 12ft before noise introduces excessive errors. For longer distances, the best solution is a shielded twisted pair like that used for audio microphones. For example, Belden 8451 works well for distances up to 100ft in a noisy environment. At the device, connect the twisted pair to DXP and DXN and the shield to GND. Leave the shield unconnected at the remote sensor.

For very long cable runs, the cable's parasitic capacitance often provides noise filtering, so the 2200pF capacitor can often be removed or reduced in value. Cable resistance also affects remote-sensor accuracy. For every 1Ω of series resistance, the error is approximately 0.5°C.

Thermal Mass and Self-Heating

When sensing local temperature, these devices are intended to measure the temperature of the PCB to which they are soldered. The leads provide a good thermal path between the PCB traces and the die. Thermal conductivity between the die and the ambient air is poor by comparison, making air temperature measurements impractical. Because the thermal mass of the PCB is far greater than that of the MAX6648/MAX6692, the devices follow temperature changes on the PCB with little or no perceivable delay.

When measuring the temperature of a CPU or other IC with an on-chip sense junction, thermal mass has virtually no effect; the measured temperature of the junction

Precision SMBus-Compatible Remote/Local Temperature Sensors with Overtemperature Alarms

Functional Diagram

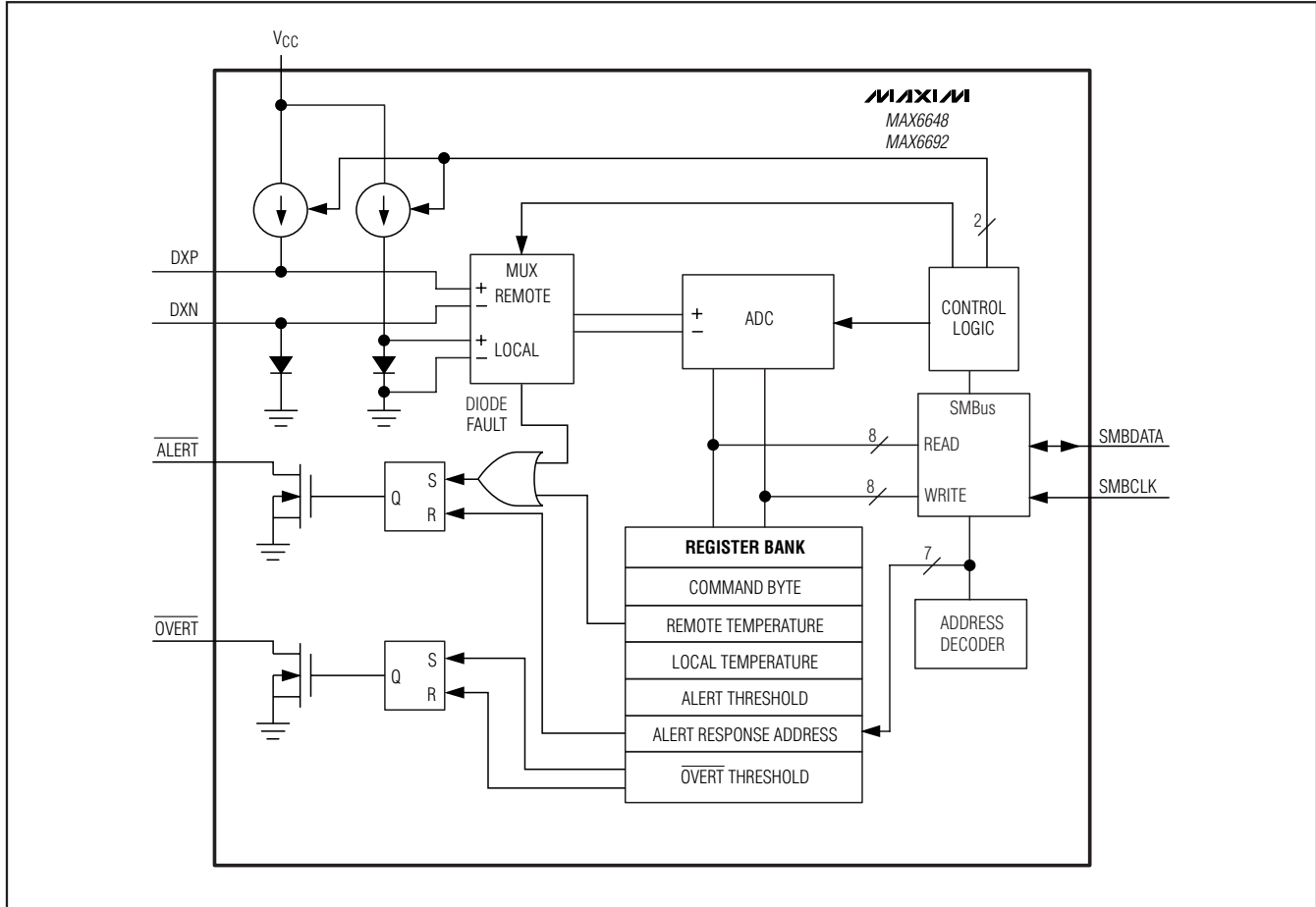

tracks the actual temperature within a conversion cycle. When measuring temperature with discrete remote sensors, smaller packages, such as SOT23s, yield the best thermal response times. Take care to account for thermal gradients between the heat source and the sensor, and ensure that stray air currents across the sensor package do not interfere with measurement accuracy.

Self-heating does not significantly affect measurement accuracy. Remote-sensor self-heating due to the diode current source is negligible. For the local diode, the worst-case error occurs when autoconverting at the

fastest rate and simultaneously sinking maximum current at the ALERT output. For example, with $V_{CC} = 5.0V$, at a 4Hz conversion rate and with ALERT sinking 1mA, the typical power dissipation is:

$$5.0V \times 500\mu A + 0.4V \times 1mA = 2.9mW$$

θ_{J-A} for the 8-pin μ MAX package is about $+221^{\circ}C/W$, so assuming no copper PCB heat sinking, the resulting temperature rise is:

$$\Delta T = 2.9mW \times (+221^{\circ}C/W) = +0.6409^{\circ}C$$

Precision SMBus-Compatible Remote/Local Temperature Sensors with Overtemperature Alarms

Pin Configuration

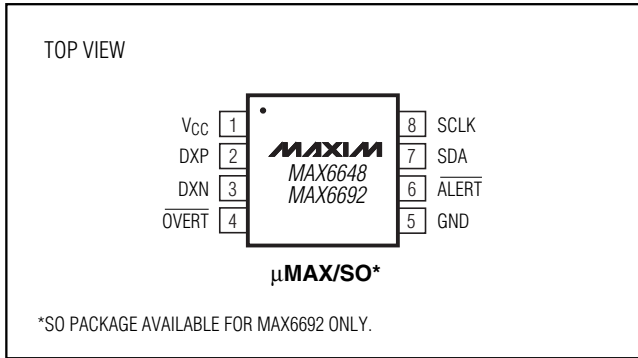

Chip Information

TRANSISTOR COUNT: 14,764
PROCESS: BICMOS

MAX6648/MAX6692

Precision SMBus-Compatible Remote/Local Temperature Sensors with Overtemperature Alarms

Package Information

(The package drawing(s) in this data sheet may not reflect the most current specifications. For the latest package outline information, go to www.maxim-ic.com/packages.)

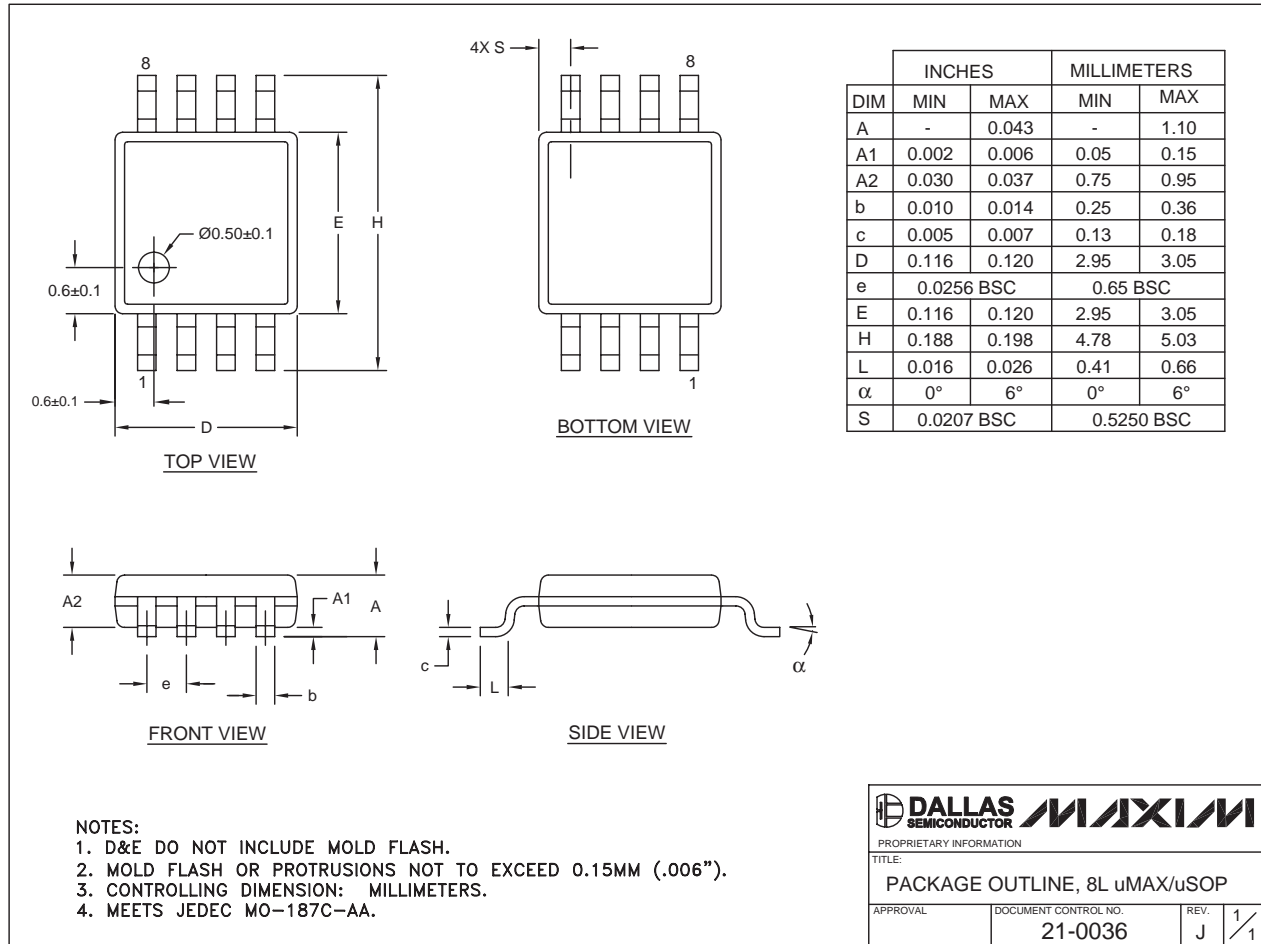

8LUMAXD EFS

Precision SMBus-Compatible Remote/Local Temperature Sensors with Overtemperature Alarms

Package Information (continued)

(The package drawing(s) in this data sheet may not reflect the most current specifications. For the latest package outline information, go to www.maxim-ic.com/packages.)

MAX6648/MAX6692

9LUCSP - 3x3.EPS

DIM	INCHES		MILLIMETERS	
	MIN	MAX	MIN	MAX
A	0.053	0.069	1.35	1.75
A1	0.004	0.010	0.10	0.25
B	0.014	0.019	0.35	0.49
C	0.007	0.010	0.19	0.25
D	0.189	0.197	4.80	5.00
e	0.050	BSC	1.27	BSC
E	0.150	0.157	3.80	4.00
H	0.228	0.244	5.80	6.20
h	0.010	0.020	0.25	0.50
L	0.016	0.050	0.40	1.27
α	0?	8?	0?	8?

NOTES:

1. D&E DO NOT INCLUDE MOLD FLASH.
2. MOLD FLASH OR PROTRUSIONS NOT TO EXCEED .15mm (.006")
3. CONTROLLING DIMENSION: MILLIMETER
4. MEETS JEDEC MS-012 AA.

MAXIM			
<small>PROPRIETARY INFORMATION</small>			
TITLE 8L SOIC OUTLINE			
<small>APPROVAL</small>	<small>DWG</small> 21-0325	<small>REV</small> A	<small>1/1</small>

Precision SMBus-Compatible Remote/Local Temperature Sensors with Overtemperature Alarms

Revision History

REVISION NUMBER	REVISION DATE	DESCRIPTION	PAGES CHANGED
0	—	—	—
1	—	—	—
2	11/05	—	—
3	12/07	Changed max SMBus timeout from 45 to 55; and various style edits.	3, 8, 13, 14

Maxim cannot assume responsibility for use of any circuitry other than circuitry entirely embodied in a Maxim product. No circuit patent licenses are implied. Maxim reserves the right to change the circuitry and specifications without notice at any time.

18 _____ **Maxim Integrated Products, 120 San Gabriel Drive, Sunnyvale, CA 94086 408-737-7600**