

GENERAL DESCRIPTION

The SP339B is an advanced multiprotocol transceiver supporting RS-232, RS-485, and RS-422 serial standards in a 40 pin QFN package. Integrated cable termination and four configuration modes allow all three protocols to be used interchangeably over a single cable or connector with no additional switching components. Full operation requires only four external charge pump capacitors.

The RS-485/422 modes feature one driver and one receiver (1TX/1RX) in both half and full duplex configurations. The RS-232 mode (3TX/5RX) provides full support of all eight signals commonly used with the DB9 RS-232 connector. A dedicated diagnostic loopback mode is also provided.

The high speed drivers operate up to 20Mbps in RS-485/422 modes, and up to 1Mbps in RS-232 mode. All drivers can be slew limited to 250kbps in any mode to minimize electromagnetic interference (EMI).

All transmitter outputs and receiver inputs feature robust electrostatic discharge (ESD) protection to $\pm 15\text{kV}$ IEC-61000-4-2 Air Gap, $\pm 8\text{kV}$ IEC-61000-4-2 Contact, and $\pm 15\text{kV}$ Human Body Model (HBM). Each receiver output has full fail-safe protection to avoid system lockup, oscillation, or indeterminate states by defaulting to logic-high output level when the inputs are open, shorted, or terminated but undriven. No external biasing resistors are required.

The RS-232 receiver inputs include a $5\text{k}\Omega$ pull-down to ground. The RS-485/422 receiver inputs are high impedance ($>96\text{k}\Omega$ when termination is disabled), allowing up to 256 devices on a single communication bus (1/8th unit load).

The SP339B operates from a single power supply, either 3.3V or 5V, with low idle current (2mA typical in all modes). The shutdown mode consumes less than $10\mu\text{A}$ for low power standby operation.

FEATURES

- Rx enabled during Tx short circuit condition
- Pin selectable Cable Termination
- No external resistors required for RS-485/422 termination and biasing
- 3.3V or 5V Single Supply Operation
- Robust ESD Protection on bus pins
 - $\pm 15\text{kV}$ IEC 61000-4-2 (Air Gap)
 - $\pm 8\text{kV}$ IEC 61000-4-2 (Contact)
 - $\pm 15\text{kV}$ Human Body Model (HBM)
- Max Data Rate of 20Mbps in RS-485/422 Modes and up to 1Mbps in RS-232 Modes
- Pin selectable 250kbps Slew Limiting
- 3 Drivers, 5 Receivers RS-232/V.28
- 1 Driver, 1 Receiver RS-485/422
 - Full and Half Duplex Configuration
 - 1/8th Unit Load, up to 256 receivers on bus
- RS-485/422 Enhanced Failsafe for open, shorted, or terminated but idle inputs
- Space saving 6mm x 6mm QFN-40 Package
- Pin compatible with SP339E and SP338E

TYPICAL APPLICATIONS

- Dual Protocol Serial Ports (RS-232 or RS-485/422)
- Industrial Computers
- Industrial and Process Control Equipment
- Point-Of-Sale Equipment
- Networking Equipment
- HVAC Controls Equipment
- Building Security and Automation Equipment

ORDERING INFORMATION⁽¹⁾

PART NUMBER	OPERATING TEMPERATURE RANGE	LEAD-FREE	PACKAGE	PACKAGING METHOD
SP339BER1-L	-40°C to +85°C	Yes ⁽²⁾	40-pin QFN	Tray
SP339BER1-L/TR	-40°C to +85°C		40-pin QFN	Tape and Reel

NOTE:

1. Refer to www.exar.com/SP339B for most up-to-date Ordering Information.
2. Visit www.exar.com for additional information on Environmental Rating.

ABSOLUTE MAXIMUM RATINGS

These are stress ratings only and functional operation of the device at these ratings or any other above those indicated in the operation sections to the specifications below is not implied. Exposure to absolute maximum rating conditions for extended periods of time may affect reliability and cause permanent damage to the device.

Supply Voltage V_{CC}	-0.3V to +6.0V
Receiver Input Voltage (from Ground)	$\pm 18V$
Driver Output Voltage (from Ground)	$\pm 18V$
Short Circuit Duration, TX out to Ground	Continuous
Voltage at TTL Input Pins	-0.3V to ($V_{CC} + 0.5V$)
Storage Temperature Range	-65°C to +150°C
Lead Temperature (soldering, 10s)	+300°C
Power Dissipation 40-pin QFN (derate 17mW/°C above +70°C)	500mW
ESD Ratings	
HBM - Human Body Model (Tx Output & Rx Input pins, R1-R9)	$\pm 15kV$
HBM - Human Body Model (All other pins)	$\pm 4kV$
IEC 61000-4-2 Airgap Discharge (Tx Output & Rx Input pins, R1-R9)	$\pm 15kV$
IEC 61000-4-2 Contact Discharge (Tx Output & Rx Input pins, R1-R9)	$\pm 8kV$

CAUTION:

ESD (ElectroStatic Discharge) sensitive device. Permanent damage may occur on unconnected devices subject to high energy electrostatic fields. Unused devices must be stored in conductive foam or shunts. Personnel should be properly grounded prior to handling this device. The protective foam should be discharged to the destination socket before devices are removed.

PIN DESCRIPTIONS BY MODE (MODE1, MODE0)

Pin	Name	00, Figure 1	01, Figure 2	10, Figure 3	11, Figure 4
1	L1	R1 Output		1	1
2	L2	R2 Output		R1 Output	R1 Output
3	L3	T1 Input		T1 Input	T1 Input
4	L4	T2 Input			
5	L6	R3 Output		1	1
6	L7	T3 Input			
7	L8	R4 Output		1	1
8	L9	R5 Output		1	1
9	VCC	V _{CC}			
10	GND	Ground			
11	SLEW	SLEW = V _{CC} enables 250kbps slew limiting			
12	DIR1			T1 Enable, R1 Disable	T1 Enable
13	N/C	This pin is not used and is not connected internally			
14	MODE0	0	1	0	1
15	MODE1	0	0	1	1
16	N/C	This pin is not used and is not connected internally			
17	TERM			Enables RS-485/422 receiver termination	
18	N/C	This pin is not used and is not connected internally			
19	ENABLE	ENABLE = V _{CC} for operation, ENABLE = 0V for shutdown			
20	VCC	V _{CC}			

PIN DESCRIPTIONS BY MODE (MODE1, MODE0)

Pin	Name	00, Figure 1	01, Figure 2	10, Figure 3	11, Figure 4
21	R9		R5 Input		
22	R8		R4 Input		
23	GND	Ground			
24	R7		T3 Output		
25	R6		R3 Input		
26	GND	Ground			
27	R4		T2 Output		R1 Input B
28	R3		T1 Output		R1 Input A
29	GND	Ground			
30	R2		R2 Input	R1 Input A, T1 Out A	T1 Out A
31	R1		R1 Input	R1 Input B, T1 Out B	T1 Out B
32	VCC	V_{CC} - 1.0 μ F to ground recommended for supply decoupling			
33	VSS	V_{SS} - Charge pump negative supply, 0.1 μ F from ground			
34	C2-	C_{2+} - Charge pump cap 2 negative lead			
35	C1-	C_{1-} - Charge pump cap 1 negative lead			
36	GND	Ground			
37	C1+	C_{1+} - Charge pump cap 1 positive lead, 0.1 μ F			
38	VCC	V_{CC}			
39	C2+	C_{2+} - Charge pump cap 2 positive lead, 0.1 μ F			
40	VDD	V_{DD} - Charge pump positive supply, 0.1 μ F to ground			

SUGGESTED DB9 CONNECTOR PINOUT

DB9 Pin	RS-232	RS-485/422 Full Duplex	RS-485 Half Duplex
1	DCD	TX-	Data-
2	RXD	TX+	Data+
3	TXD	RX+	
4	DTR	RX-	
5	Ground		
6	DSR		
7	RTS		
8	CTS		
9	RI		

ELECTRICAL CHARACTERISTICS

UNLESS OTHERWISE NOTED:

 $V_{CC} = +3.3V \pm 5\%$ or $+5.0V \pm 5\%$, $C1-C4 = 0.1\mu F$; $T_A = T_{MIN}$ to T_{MAX} . Typical values are at $V_{CC} = 3.3V$, $T_A = +25^\circ C$.

SYMBOL	PARAMETERS	MIN.	TYP.	MAX.	UNITS	CONDITIONS
DC CHARACTERISTICS						
I_{CC}	Supply Current (RS-232)		2	8	mA	No load, idle inputs
I_{CC}	Supply Current (RS-485)		2	8	mA	No load, idle inputs
I_{CC}	Vcc Shutdown Current		1	10	μA	ENABLE = 0V
TRANSMITTER and LOGIC INPUT PINS: Pins 3, 4, 6, 11, 12, 14, 15, 17-19						
V_{IH}	Logic Input Voltage High	2.0			V	$V_{CC} = 3.3V$
V_{IH}	Logic Input Voltage High	2.4			V	$V_{CC} = 5.0V$
V_{IL}	Logic Input Voltage Low			0.8	V	
I_{IL}	Logic Input Leakage Current Low			1	μA	Input Low ($V_{IN} = 0V$)
I_{IH}	Logic Input Leakage Current High			1	μA	Input High ($V_{IN} = V_{CC}$), pins 3, 4 and 6
I_{PD}	Logic Input Pull-down Current			50	μA	Input High ($V_{IN} = V_{CC}$), pins 11, 12, 14, 15, 17-19
V_{HYS}	Logic Input Hysteresis		200		mV	
RECEIVER OUTPUTS: Pins 1, 2, 5, 7, 8						
V_{OH}	Receiver Output Voltage High	$V_{CC}-0.6$			V	$I_{OUT} = -1.5mA$
V_{OL}	Receiver Output Voltage Low			0.4	V	$I_{OUT} = 2.5mA$
I_{OSS}	Receiver Output Short Circuit Current		± 20	± 60	mA	$0 \leq V_O \leq V_{CC}$
I_{OZ}	Receiver Output Leakage Current		± 0.1	± 1	μA	$0 \leq V_O \leq V_{CC}$, Receivers disabled

ELECTRICAL CHARACTERISTICS (Continued)
UNLESS OTHERWISE NOTED:
 $V_{CC} = +3.3V \pm 5\%$ or $+5.0V \pm 5\%$, $C1-C4 = 0.1\mu F$; $T_A = T_{MIN}$ to T_{MAX} . Typical values are at $V_{CC} = 3.3V$, $T_A = +25^\circ C$.

SYMBOL	PARAMETERS	MIN.	TYP.	MAX.	UNITS	CONDITIONS
SINGLE-ENDED RECEIVER INPUTS (RS-232)						
V_{IN}	Input Voltage Range	-15		+15	V	
V_{IL}	Input Threshold Low	0.6	1.2		V	$V_{CC} = 3.3V$
		0.8	1.5		V	$V_{CC} = 5.0V$
V_{IH}	Input Threshold High		1.5	2.0	V	$V_{CC} = 3.3V$
			1.8	2.4	V	$V_{CC} = 5.0V$
V_{HYS}	Input Hysteresis		0.3		V	
R_{IN}	Input Resistance	3	5	7	$k\Omega$	$-15V \leq V_{IN} \leq +15V$
SINGLE-ENDED DRIVER OUTPUTS (RS-232)						
V_O	Output Voltage Swing	± 5.0	± 5.5		V	Output loaded with $3k\Omega$ to Gnd
				± 7.0	V	No load output
I_{SC}	Short Circuit Current			± 60	mA	$V_O = 0V$
R_{OFF}	Power Off Impedance	300	10M		Ω	$V_{CC} = 0V$, $V_O = \pm 2V$

ELECTRICAL CHARACTERISTICS (Continued)

UNLESS OTHERWISE NOTED:

 $V_{CC} = +3.3V \pm 5\%$ or $+5.0V \pm 5\%$, $C1-C4 = 0.1\mu F$; $T_A = T_{MIN}$ to T_{MAX} . Typical values are at $V_{CC} = 3.3V$, $T_A = +25^\circ C$.

SYMBOL	PARAMETERS	MIN.	TYP.	MAX.	UNITS	CONDITIONS
DIFFERENTIAL RECEIVER INPUTS (RS-485 / RS-422)						
R_{IN}	Receiver Input Resistance	96			$k\Omega$	TERM = 0V, $-7V \leq V_{IN} \leq +12V$
V_{TH}	Receiver Differential Threshold Voltage	-200	-125	-50	mV	
ΔV_{TH}	Receiver Input Hysteresis		25		mV	$V_{CM} = 0V$
I_{IN}	Receiver Input Current			125	μA	$V_{IN} = +12V$
				-100	μA	$V_{IN} = -7V$
R_{TERM}	Termination Resistance	100	120	155	Ω	TERM = V_{CC} , Figure 5 $-7V \leq V_{CM} \leq +12V$
R_{TERM}	Termination Resistance	100	120	140	Ω	TERM = V_{CC} , Figure 5 $V_{CM} = 0V$
DIFFERENTIAL DRIVER OUTPUTS (RS-485 / RS-422)						
V_{OD}	Differential Driver Output	2		V_{CC}	V	$R_L = 100\Omega$ (RS-422), Figure 6
		1.5		V_{CC}	V	$R_L = 54\Omega$ (RS-485), Figure 6
		1.5		V_{CC}	V	$-7V \leq V_{CM} \leq +12V$, Figure 7
				V_{CC}	V	No Load
ΔV_{OD}	Change In Magnitude of Differential Output Voltage	-0.2		+0.2	V	$R_L = 54\Omega$ or 100Ω , Figure 6
V_{CM}	Driver Common Mode Output Voltage			3	V	$R_L = 54\Omega$ or 100Ω , Figure 6
ΔV_{CM}	Change In Magnitude of Common Mode Output Voltage			0.2	V	$R_L = 54\Omega$ or 100Ω , Figure 6
I_{OSD}	Driver Output Short Circuit Current	-250		250	mA	$-7V \leq V_O \leq +12V$, Figure 8
I_O	Driver Output Leakage Current			100	μA	DIR1 = 0V in Mode 11, or ENABLE = 0V, $V_O = +12V$, $V_{CC} = 0V$ or 5.25V
		-100			μA	DIR1 = 0V in Mode 11, or ENABLE = 0V, $V_O = -7V$, $V_{CC} = 0V$ or 5.25V

TIMING CHARACTERISTICS
UNLESS OTHERWISE NOTED:
 $V_{CC} = +3.3V \pm 5\%$ or $+5.0V \pm 5\%$, $C_1-C_4 = 0.1\mu F$; $T_A = T_{MIN}$ to T_{MAX} . Typical values are at $V_{CC} = 3.3V$, $T_A = +25^\circ C$.

SYMBOL	PARAMETERS	MIN.	TYP.	MAX.	UNITS	CONDITIONS
ALL MODES						
t_{ENABLE}	Enable from Shutdown		1000		ns	
$t_{SHUTDOWN}$	Enable to Shutdown		1000		ns	
RS-232, DATA RATE = 250kbps (SLEW = V_{CC}), ONE TRANSMITTER SWITCHING						
	Maximum Data Rate	250			kbps	$R_L = 3k\Omega$, $C_L = 1000pF$
t_{RHL} , t_{RLH}	Receiver Propagation Delay		100		ns	$C_L = 150pF$, Figure 9
$ t_{RHL}-t_{RLH} $	Receiver Propagation Delay Skew			100	ns	
t_{DHL} , t_{DLH}	Driver Propagation Delay		1400		ns	$R_L = 3k\Omega$, $C_L = 2500pF$, Figure 10
$ t_{DHL}-t_{DLH} $	Driver Propagation Delay Skew			600	ns	
t_{SHL} , t_{SLH}	Transition Region Slew Rate from +3.0V to -3.0V or -3.0V to +3.0V	4		30	V/ μs	$V_{CC} = 3.3V$, $R_L = 3k\Omega$ to $7k\Omega$, $C_L = 150pF$ to $2500pF$, Figure 10
t_{SHL} , t_{SLH}	Transition Region Slew Rate from +3.0V to -3.0V or -3.0V to +3.0V	6		30	V/ μs	$V_{CC} = 3.3V$, $R_L = 3k\Omega$ to $7k\Omega$, $C_L = 150pF$ to $2500pF$, $T_A = 25^\circ C$, Figure 10
RS-232, DATA RATE = 1Mbps (SLEW = 0V), ONE TRANSMITTER SWITCHING						
	Maximum Data Rate	1			Mbps	$R_L = 3k\Omega$, $C_L = 250pF$
t_{RHL} , t_{RLH}	Receiver Propagation Delay		100		ns	$C_L = 150pF$, Figure 9
$ t_{RHL}-t_{RLH} $	Receiver Propagation Delay Skew			100	ns	
t_{DHL} , t_{DLH}	Driver Propagation Delay		300		ns	$R_L = 3k\Omega$, $C_L = 1000pF$, Figure 10
$ t_{DHL}-t_{DLH} $	Driver Propagation Delay Skew			150	ns	
t_{SHL} , t_{SLH}	Transition Region Slew Rate from +3.0V to -3.0V or -3.0V to +3.0V	15		150	V/ μs	$V_{CC} = 3.3V$, $R_L = 3k\Omega$ to $7k\Omega$, $C_L = 150pF$ to $1000pF$, Figure 10
t_{SHL} , t_{SLH}	Transition Region Slew Rate from +3.0V to -3.0V or -3.0V to +3.0V	24		150	V/ μs	$V_{CC} = 3.3V$, $R_L = 3k\Omega$ to $7k\Omega$, $C_L = 150pF$ to $1000pF$, $T_A = 25^\circ C$, Figure 10

TIMING CHARACTERISTICS (Continued)

UNLESS OTHERWISE NOTED:

$V_{CC} = +3.3V \pm 5\%$ or $+5.0V \pm 5\%$, $C1-C4 = 0.1\mu F$; $T_A = T_{MIN}$ to T_{MAX} . Typical values are at $V_{CC} = 3.3V$, $T_A = +25^\circ C$.

SYMBOL	PARAMETERS	MIN.	TYP.	MAX.	UNITS	CONDITIONS
RS-485/RS-422, DATA RATE = 250kbps (SLEW = V_{CC}), ONE TRANSMITTER SWITCHING						
	Maximum Data Rate	250			kbps	$R_L = 54\Omega$, $C_L = 50pF$
t_{RPHL} , t_{RPLH}	Receiver Propagation Delay		50	150	ns	$C_L = 15pF$, Figure 11
$ t_{RPHL} - t_{RPLH} $	Receiver Propagation Delay Skew			20	ns	
t_{DPHL} , t_{DPLH}	Driver Propagation Delay		500	1000	ns	$R_L = 54\Omega$, $C_L = 50pF$, Figure 12
$ t_{DPHL} - t_{DPLH} $	Driver Propagation Delay Skew			100	ns	
t_{DR} , t_{DF}	Driver Rise and Fall Time	300	650	1200	ns	
RS-485/RS-422, DATA RATE = 20Mbps (SLEW = 0V), ONE TRANSMITTER SWITCHING						
	Maximum Data Rate	20			Mbps	$R_L = 54\Omega$, $C_L = 50pF$
t_{RPHL} , t_{RPLH}	Receiver Propagation Delay		50	150	ns	$C_L = 15pF$, Figure 11
$ t_{RPHL} - t_{RPLH} $	Receiver Propagation Delay Skew			10	ns	
t_{DPHL} , t_{DPLH}	Driver Propagation Delay		30	100	ns	$R_L = 54\Omega$, $C_L = 50pF$, Figure 12
$ t_{DPHL} - t_{DPLH} $	Driver Propagation Delay Skew			10	ns	
t_{DR} , t_{DF}	Driver Rise and Fall Time		10	20	ns	
RS-485/RS-422, DATA RATE = 20Mbps (SLEW = 0V), ONE TRANSMITTER SWITCHING						
t_{RZH} , t_{RZL}	Receiver Output Enable Time			200	ns	$C_L = 15pF$, Figure 13
t_{RHZ} , t_{RLZ}	Receiver Output Disable Time			200	ns	
t_{DZH} , t_{DZL}	Driver Output Enable Time			200	ns	$R_L = 500\Omega$, $C_L = 50pF$, Figure 14
t_{DHZ} , t_{DLZ}	Driver Output Disable Time			200	ns	

BLOCK DIAGRAM BY MODE (MODE1, MODE0)

FIGURE 1. MODE 00 - LOOPBACK

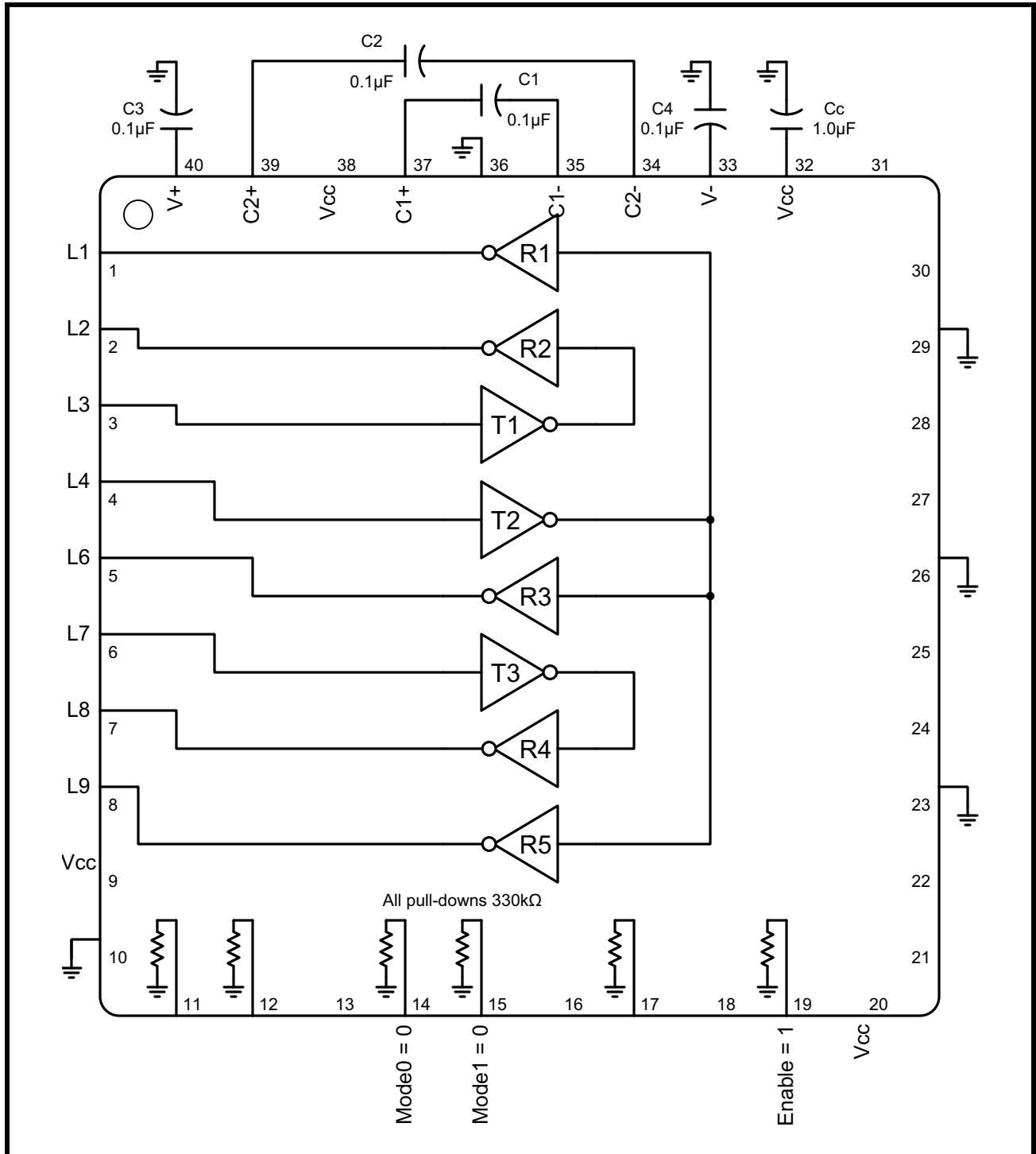

FIGURE 2. MODE 01 - RS-232

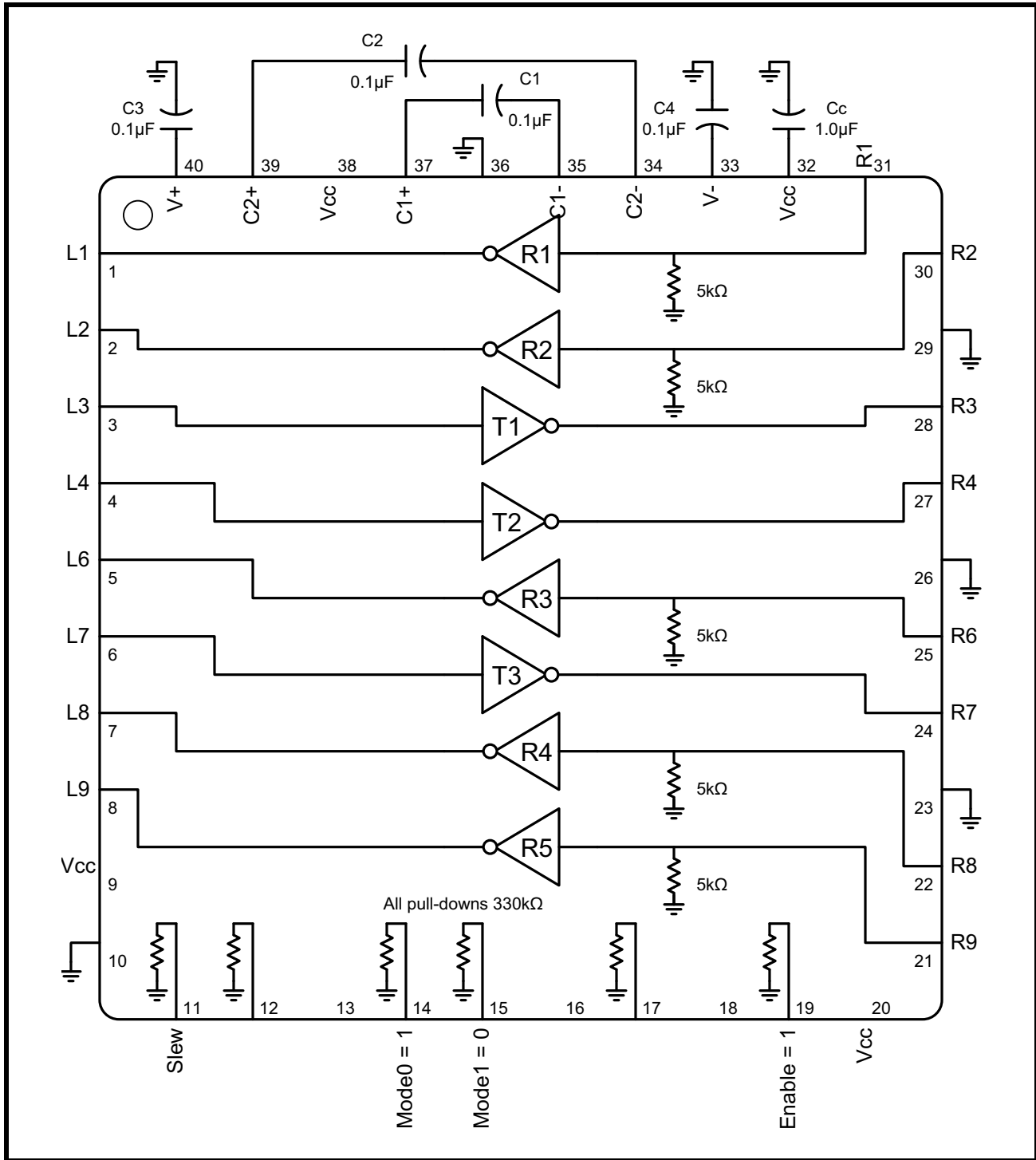

FIGURE 3. MODE 10 - RS-485 HALF DUPLEX

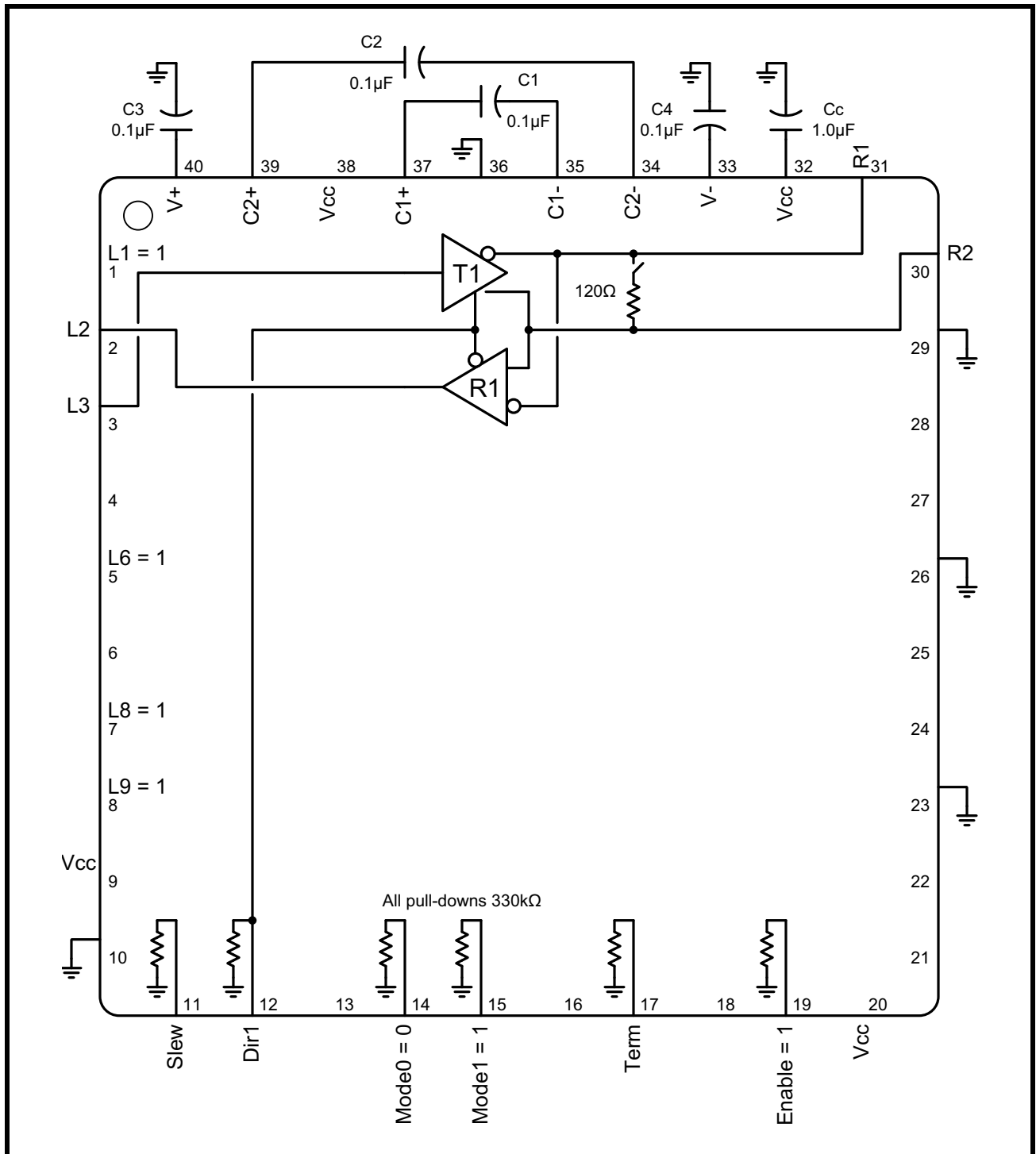
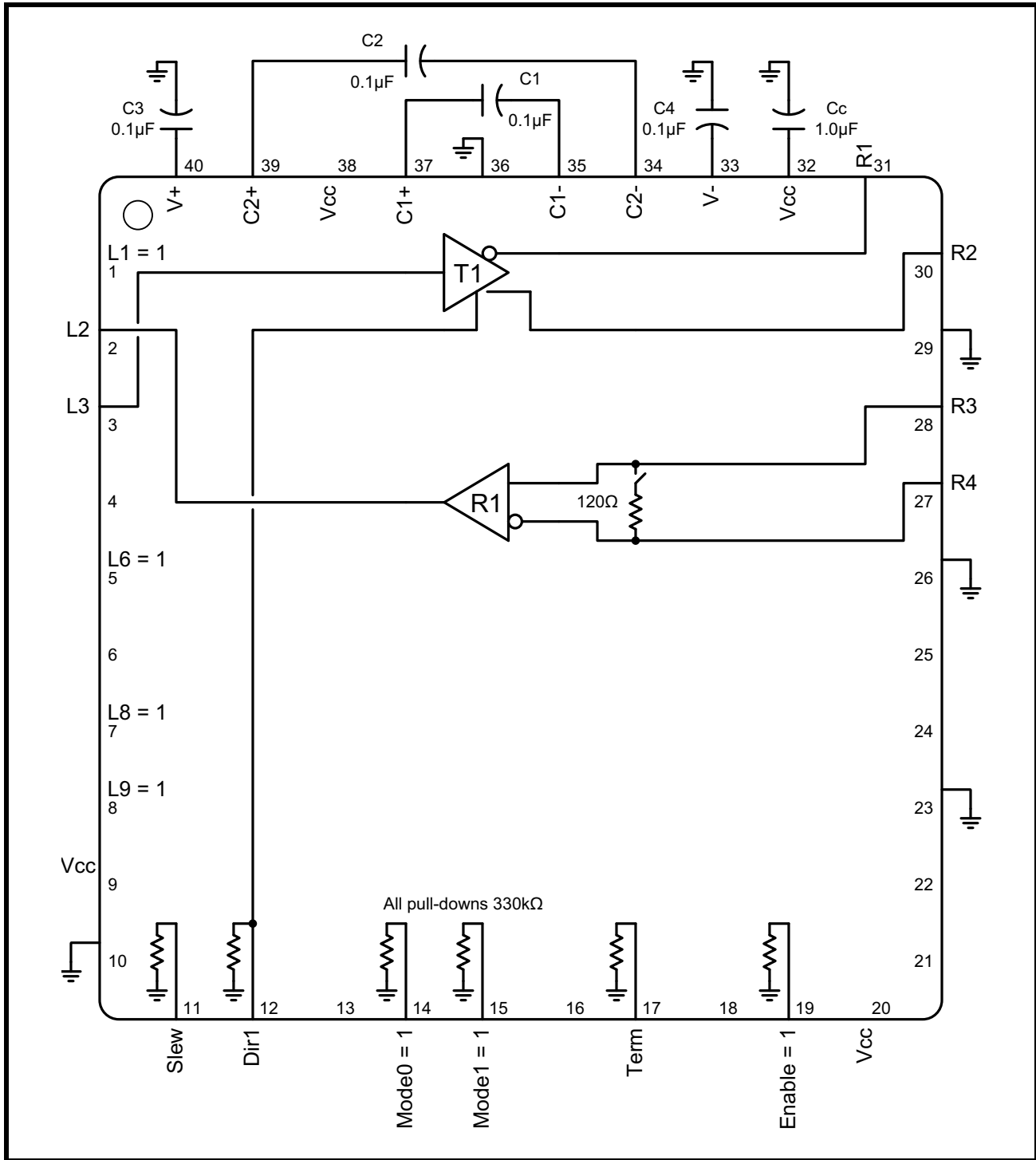

FIGURE 4. MODE 11 - RS-485/422 FULL DUPLEX



TEST CIRCUITS

FIGURE 5. RS-485/422 RECEIVER TERMINATION RESISTANCE

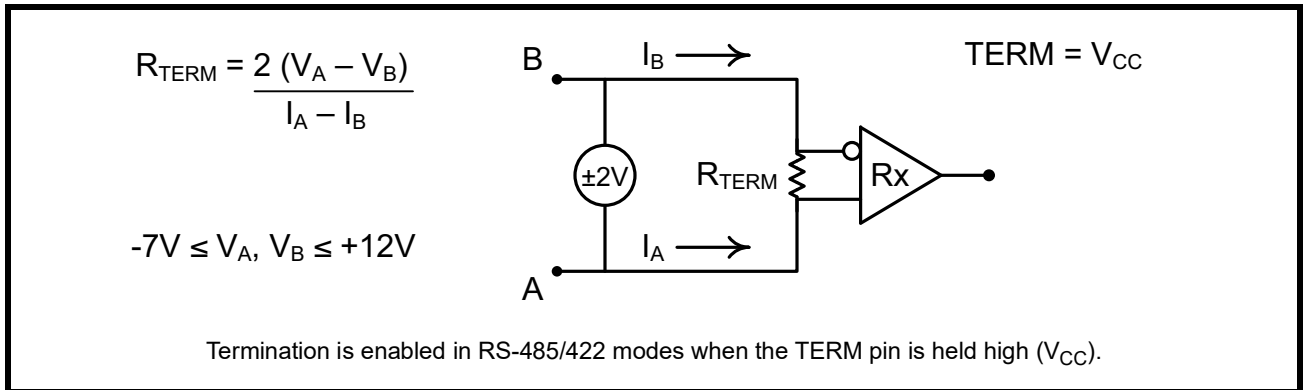

FIGURE 6. RS-485/422 DIFFERENTIAL DRIVER OUTPUT VOLTAGE

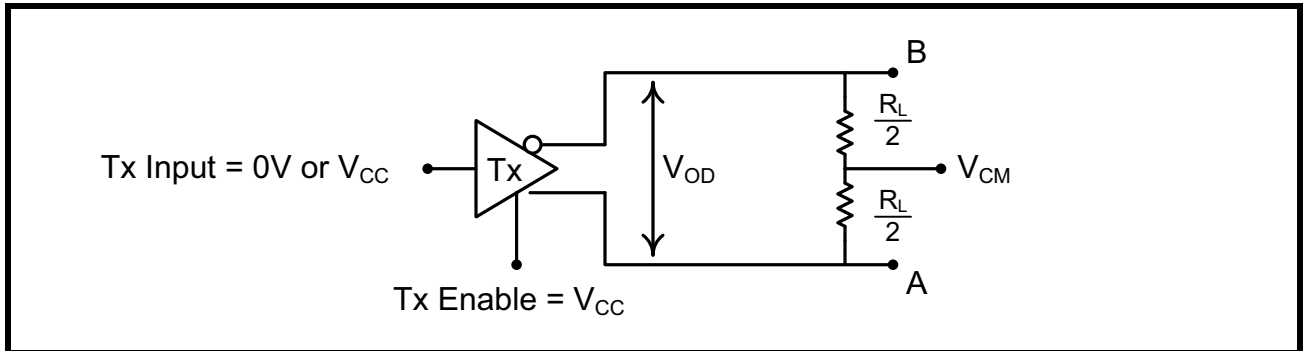

FIGURE 7. RS-485/422 DIFFERENTIAL DRIVER OUTPUT VOLTAGE OVER COMMON MODE

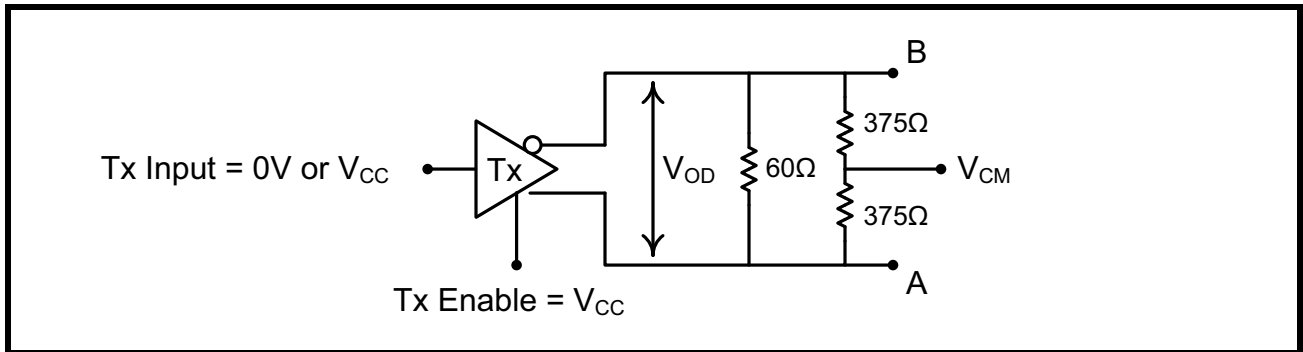

FIGURE 8. RS-485/422 DRIVER OUTPUT SHORT CIRCUIT CURRENT

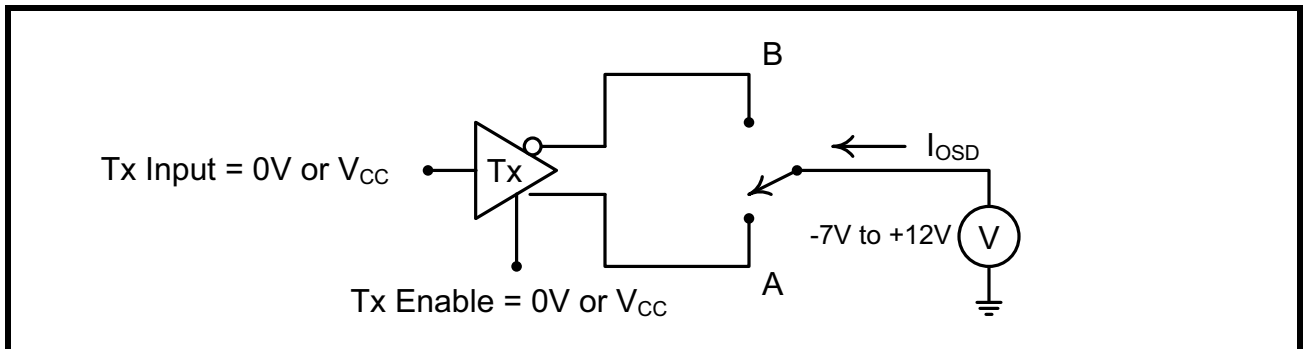

FIGURE 9. RS-232 RECEIVER PROPAGATION DELAY

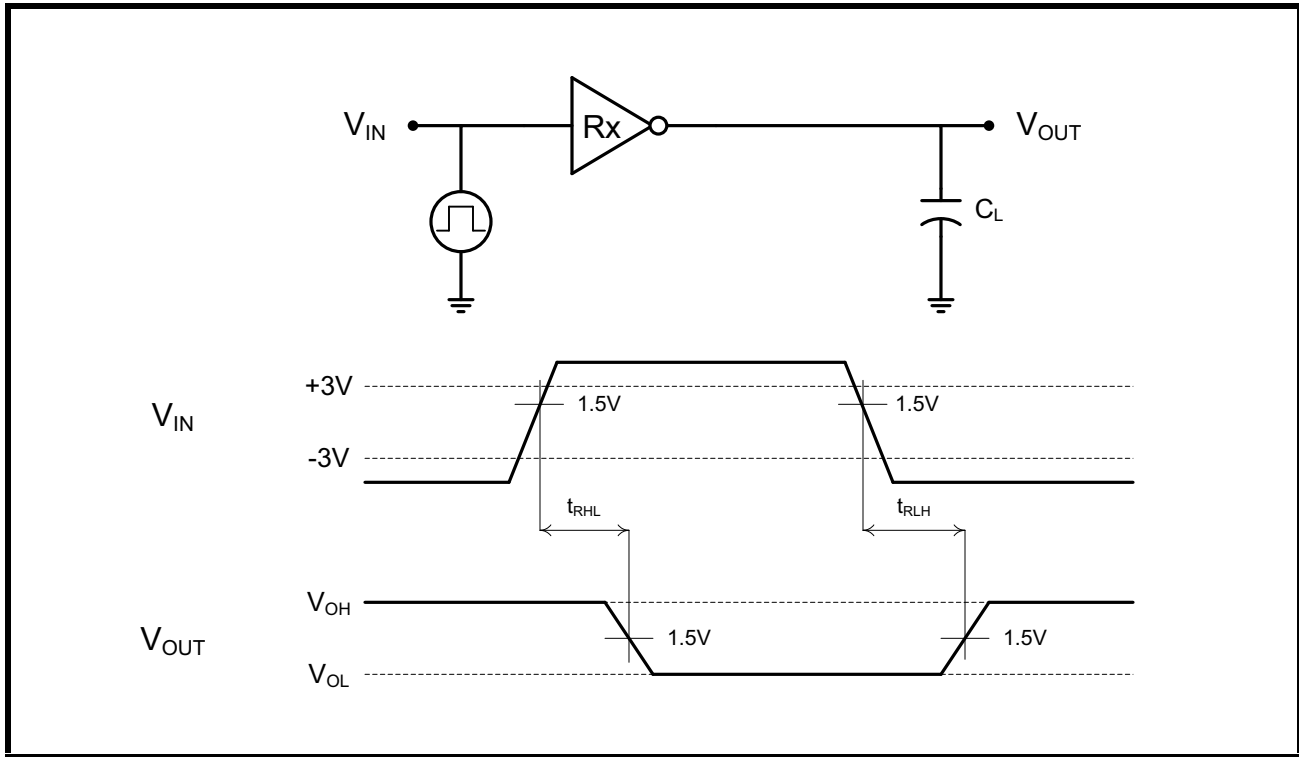

FIGURE 10. RS-232 DRIVER PROPAGATION DELAY

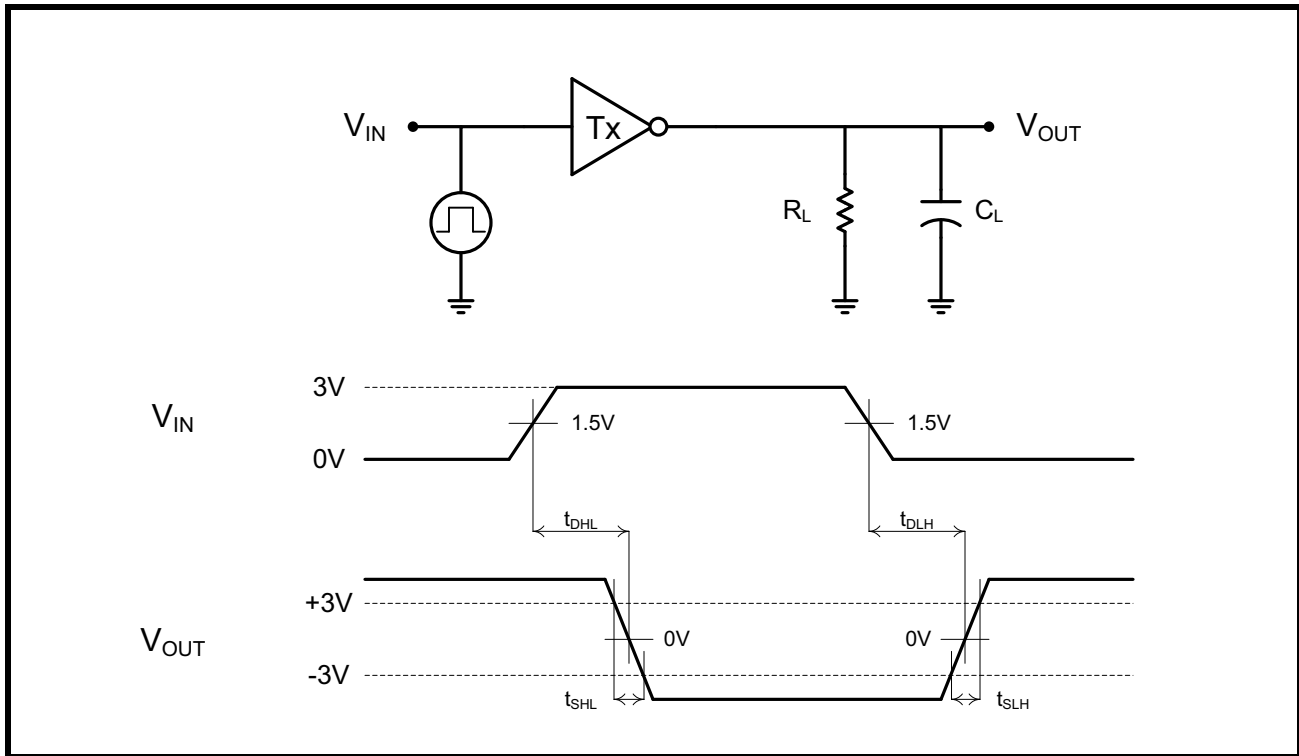

FIGURE 11. RS-485/422 RECEIVER PROPAGATION DELAY

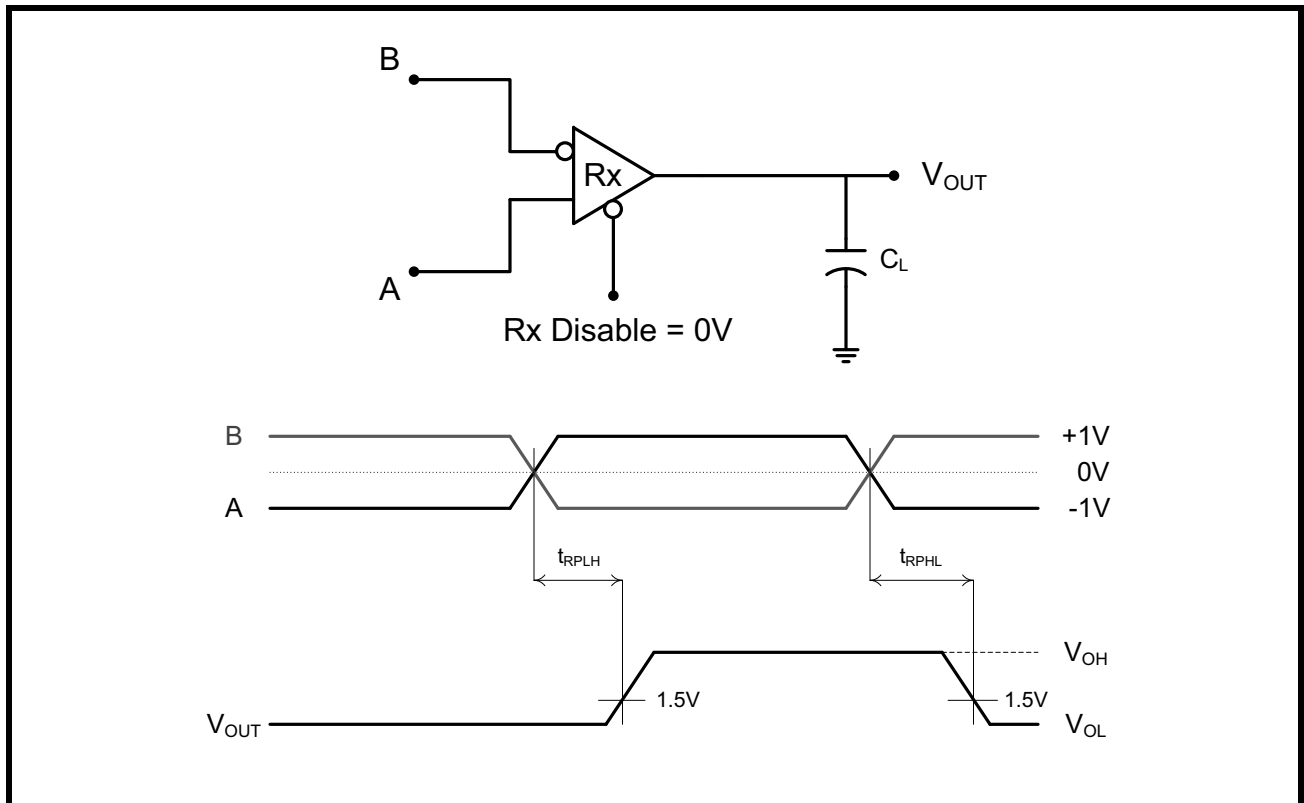

FIGURE 12. RS-485/422 DRIVER PROPAGATION DELAY AND RISE/FALL TIMES

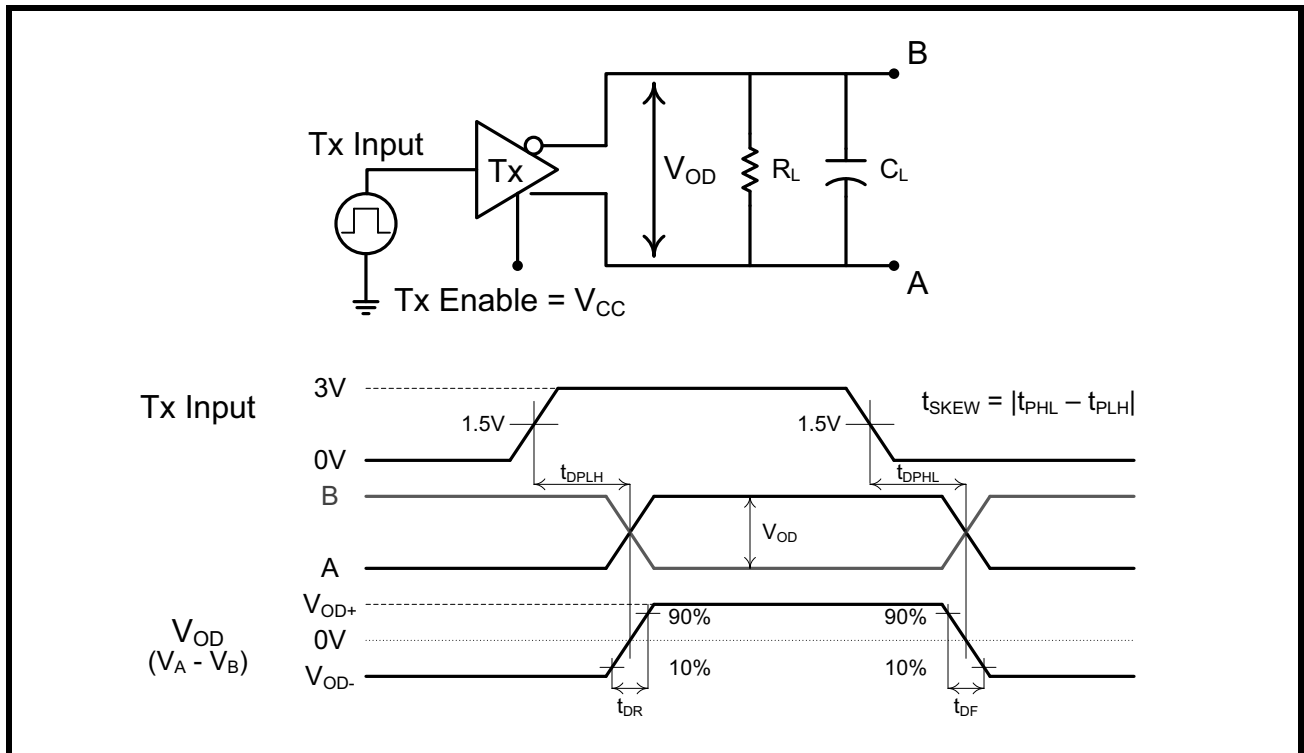

FIGURE 13. RS-485/422 RECEIVER OUTPUT ENABLE/DISABLE TIMES

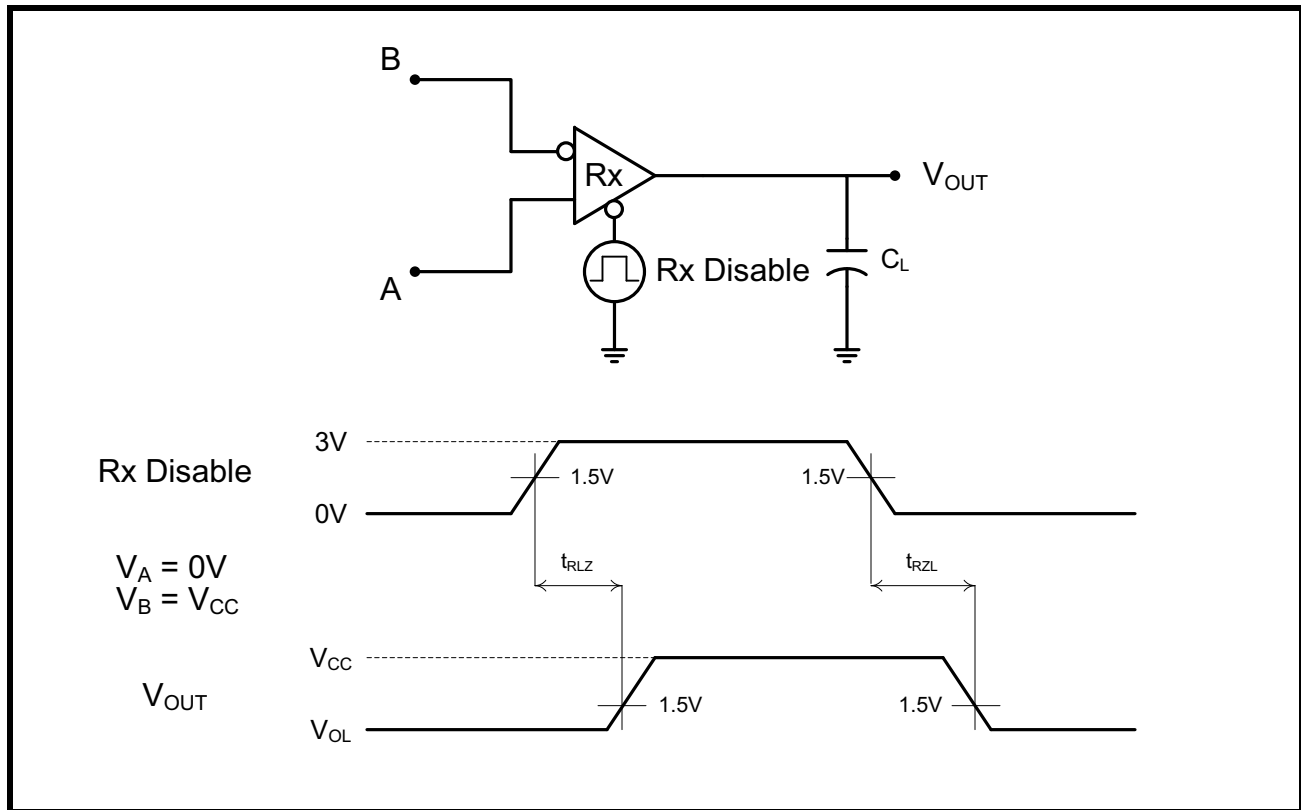
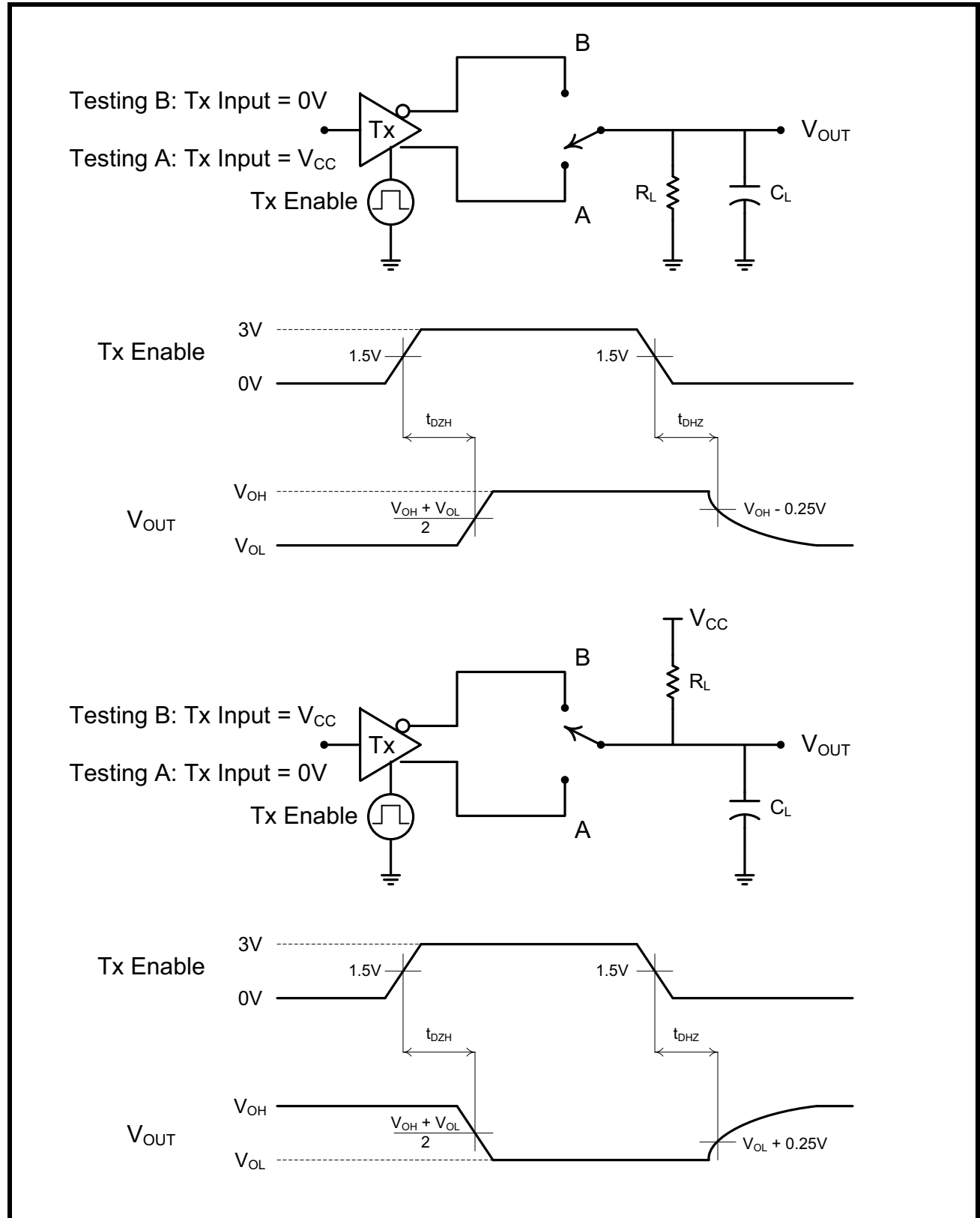

FIGURE 14. RS-485/422 DRIVER OUTPUT ENABLE/DISABLE TIMES



PRODUCT SUMMARY

The SP339B is an advanced multiprotocol transceiver supporting RS-232, RS-485, and RS-422 serial standards in a 40 pin QFN package. Integrated cable termination and four configuration modes allow all three protocols to be used interchangeably over a single cable or connector with no additional switching components. The RS-485/422 modes feature one driver and one receiver (1TX/1RX) in both half and full duplex configurations. The RS-232 mode (3TX/5RX) provides full support of all eight signals commonly used with the DB9 RS-232 connector. A dedicated mode is also available for diagnostic loopback testing.

INTERNALLY SWITCHED CABLE TERMINATION

Enabling and disabling the RS-485/422 termination resistor is one of the largest challenges system designers face when sharing a single connector or pair of lines across multiple serial protocols. A termination resistor may be necessary for accurate RS-485/422 communication, but must be removed when the lines are used for RS-232. SP339B provides an elegant solution to this problem by integrating the termination resistor and switching control, and allowing it to be switched in and out of the circuit with a single pin. No external switching components are required.

ENHANCED FAILSAFE

Ordinary RS-485 differential receivers will be in an indeterminate state whenever the data bus is not being actively driven. The enhanced failsafe feature of the SP339B guarantees a logic-high receiver output when the receiver inputs are open, shorted, or terminated but idle/undriven. The enhanced failsafe interprets 0V differential as a logic high with a minimum 50mV noise margin, while maintaining compliance with the EIA/TIA-485 standard of $\pm 200\text{mV}$. No external biasing resistors are required, further easing the usage of multiple protocols over a single connector.

$\pm 15\text{kV}$ ESD PROTECTION

ESD protection structures are incorporated on all pins to protect against electrostatic discharges encountered during handling and assembly. The bus pins (driver outputs and receiver inputs) have extra protection structures, which have been tested up to $\pm 15\text{kV}$ without damage. These structures withstand high ESD in all states: normal operation, shutdown and powered down.

ESD protection is tested in various ways. MaxLinear uses the following methods to qualify the protection structures designed into SP339B:

- $\pm 15\text{kV}$ using the Human Body Model (HBM)
- $\pm 8\text{kV}$ using IEC 61000-4-2 Contact Discharge
- $\pm 15\text{kV}$ using IEC 61000-4-2 Air Gap Discharge

The IEC 61000-4-2 standard is more rigorous than HBM, resulting in lower voltage levels compared with HBM for the same level of ESD protection. Because IEC 61000-4-2 specifies a lower series resistance, the peak current is higher than HBM. The SP339B has passed both HBM and IEC 61000-4-2 testing without damage.

DIAGNOSTIC LOOPBACK MODE

The SP339B includes a diagnostic digital loop back mode for system testing as shown in [Figure 1](#). The loopback mode connects the TTL driver inputs to the TTL receiver outputs, bypassing the analog driver and receiver circuitry. The analog/bus pins are internally disconnected in this mode.

RECOMMENDED LAND PATTERN AND STENCIL

FIGURE 16. QFN-40 RECOMMENDED PCB LAND PATTERN AND STENCIL

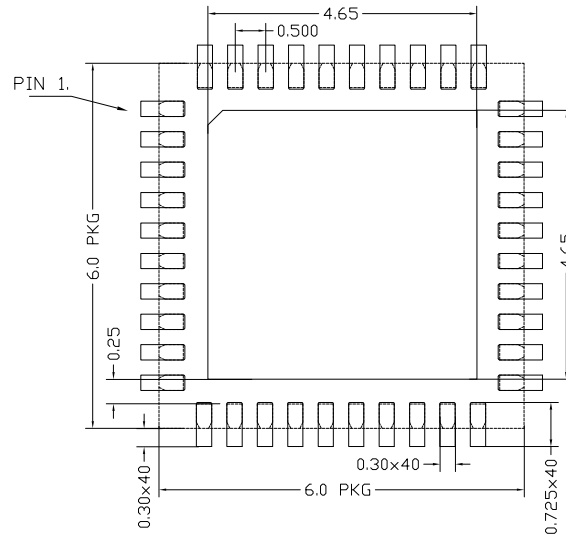

TYPICAL RECOMMENDED LAND PATTERN

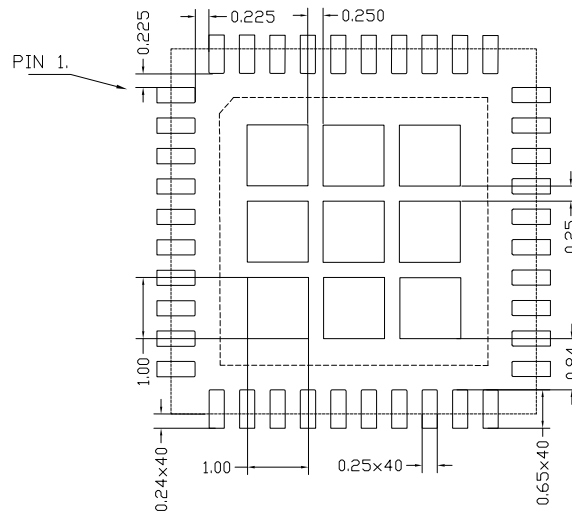

TYPICAL RECOMMENDED STENCIL

Drawing No.: POD-00000041

Revision: B.3

FIGURE 17. PIN 1 ORIENTATION IN TAPE

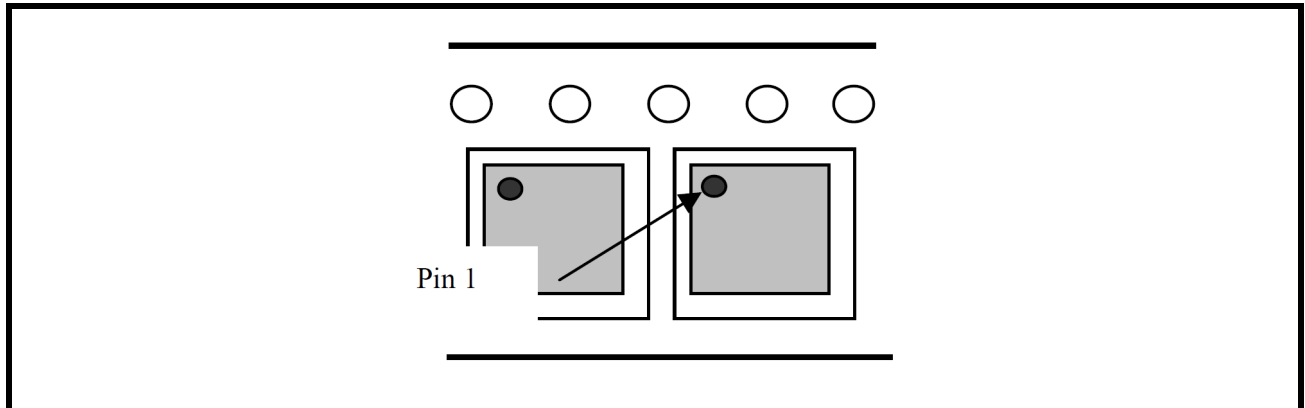

REVISION HISTORY

DATE	REVISION	DESCRIPTION
November 2014	1.0.0	Initial release
February 2018	1.0.1	Update to MaxLinear logo. Update format and Ordering Information. Corrected typo for pin 28, Mode 11 in Pin Description. Moved ESD ratings on page 2.
January 2019	1.0.2	Corrected typo in recommended stencil.

**Corporate Headquarters:**

5966 LaPlace Court
Suite 100
Carlsbad, CA 92008
Tel.:+1 (760) 692-0711
Fax:+1 (760) 444-8598
www.maxlinear.com

The content of this document is furnished for informational use only, is subject to change without notice, and should not be construed as a commitment by MaxLinear, Inc. MaxLinear, Inc. assumes no responsibility or liability for any errors or inaccuracies that may appear in the informational content contained in this guide. Complying with all applicable copyright laws is the responsibility of the user. Without limiting the rights under copyright, no part of this document may be reproduced into, stored in, or introduced into a retrieval system, or transmitted in any form or by any means (electronic, mechanical, photocopying, recording, or otherwise), or for any purpose, without the express written permission of MaxLinear, Inc.

MaxLinear, Inc. does not recommend the use of any of its products in life support applications where the failure or malfunction of the product can reasonably be expected to cause failure of the life support system or to significantly affect its safety or effectiveness. Products are not authorized for use in such applications unless MaxLinear, Inc. receives, in writing, assurances to its satisfaction that: (a) the risk of injury or damage has been minimized; (b) the user assumes all such risks; (c) potential liability of MaxLinear, Inc. is adequately protected under the circumstances.

MaxLinear, Inc. may have patents, patent applications, trademarks, copyrights, or other intellectual property rights covering subject matter in this document. Except as expressly provided in any written license agreement from MaxLinear, Inc., the furnishing of this document does not give you any license to these patents, trademarks, copyrights, or other intellectual property.

MaxLinear, the MaxLinear logo, and any MaxLinear trademarks, MxL, Full-Spectrum Capture, FSC, G.now, AirPHY and the MaxLinear logo are all on the products sold, are all trademarks of MaxLinear, Inc. or one of MaxLinear's subsidiaries in the U.S.A. and other countries. All rights reserved. Other company trademarks and product names appearing herein are the property of their respective owners.

© 2011 - 2019 MaxLinear, Inc. All rights reserved.