



**MICROCHIP**

---

**PICkit™ 3 Starter Kit  
User's Guide**

---

---

**Note the following details of the code protection feature on Microchip devices:**

- Microchip products meet the specification contained in their particular Microchip Data Sheet.
- Microchip believes that its family of products is one of the most secure families of its kind on the market today, when used in the intended manner and under normal conditions.
- There are dishonest and possibly illegal methods used to breach the code protection feature. All of these methods, to our knowledge, require using the Microchip products in a manner outside the operating specifications contained in Microchip's Data Sheets. Most likely, the person doing so is engaged in theft of intellectual property.
- Microchip is willing to work with the customer who is concerned about the integrity of their code.
- Neither Microchip nor any other semiconductor manufacturer can guarantee the security of their code. Code protection does not mean that we are guaranteeing the product as "unbreakable."

Code protection is constantly evolving. We at Microchip are committed to continuously improving the code protection features of our products. Attempts to break Microchip's code protection feature may be a violation of the Digital Millennium Copyright Act. If such acts allow unauthorized access to your software or other copyrighted work, you may have a right to sue for relief under that Act.

---

Information contained in this publication regarding device applications and the like is provided only for your convenience and may be superseded by updates. It is your responsibility to ensure that your application meets with your specifications. MICROCHIP MAKES NO REPRESENTATIONS OR WARRANTIES OF ANY KIND WHETHER EXPRESS OR IMPLIED, WRITTEN OR ORAL, STATUTORY OR OTHERWISE, RELATED TO THE INFORMATION, INCLUDING BUT NOT LIMITED TO ITS CONDITION, QUALITY, PERFORMANCE, MERCHANTABILITY OR FITNESS FOR PURPOSE. Microchip disclaims all liability arising from this information and its use. Use of Microchip devices in life support and/or safety applications is entirely at the buyer's risk, and the buyer agrees to defend, indemnify and hold harmless Microchip from any and all damages, claims, suits, or expenses resulting from such use. No licenses are conveyed, implicitly or otherwise, under any Microchip intellectual property rights.

#### **Trademarks**

The Microchip name and logo, the Microchip logo, dsPIC, FlashFlex, KEELOQ, KEELOQ logo, MPLAB, PIC, PICmicro, PICSTART, PIC<sup>32</sup> logo, rPIC, SST, SST Logo, SuperFlash and UNI/O are registered trademarks of Microchip Technology Incorporated in the U.S.A. and other countries.

FilterLab, Hampshire, HI-TECH C, Linear Active Thermistor, MTP, SEEVAL and The Embedded Control Solutions Company are registered trademarks of Microchip Technology Incorporated in the U.S.A.

Silicon Storage Technology is a registered trademark of Microchip Technology Inc. in other countries.

Analog-for-the-Digital Age, Application Maestro, BodyCom, chipKIT, chipKIT logo, CodeGuard, dsPICDEM, dsPICDEM.net, dsPICworks, dsSPEAK, ECAN, ECONOMONITOR, FanSense, HI-TIDE, In-Circuit Serial Programming, ICSP, Mindi, MiWi, MPASM, MPF, MPLAB Certified logo, MPLIB, MPLINK, mTouch, Omniscent Code Generation, PICC, PICC-18, PICDEM, PICDEM.net, PICkit, PICtail, REAL ICE, rLAB, Select Mode, SQI, Serial Quad I/O, Total Endurance, TSHARC, UniWinDriver, WiperLock, ZENA and Z-Scale are trademarks of Microchip Technology Incorporated in the U.S.A. and other countries.

SQTP is a service mark of Microchip Technology Incorporated in the U.S.A.

GestIC and ULPP are registered trademarks of Microchip Technology Germany II GmbH & Co. & KG, a subsidiary of Microchip Technology Inc., in other countries.

All other trademarks mentioned herein are property of their respective companies.

© 2012, Microchip Technology Incorporated, Printed in the U.S.A., All Rights Reserved.

 Printed on recycled paper.

ISBN: 9781620766064

**QUALITY MANAGEMENT SYSTEM**  
**CERTIFIED BY DNV**  
**== ISO/TS 16949 ==**

*Microchip received ISO/TS-16949:2009 certification for its worldwide headquarters, design and wafer fabrication facilities in Chandler and Tempe, Arizona; Gresham, Oregon and design centers in California and India. The Company's quality system processes and procedures are for its PIC<sup>®</sup> MCUs and dsPIC<sup>®</sup> DSCs, KEELOQ<sup>®</sup> code hopping devices, Serial EEPROMs, microperipherals, nonvolatile memory and analog products. In addition, Microchip's quality system for the design and manufacture of development systems is ISO 9001:2000 certified.*



# MICROCHIP PICKit™ 3 STARTER KIT USER'S GUIDE

## Table of Contents

### Chapter 1. Overview

1.1	Introduction .....	13
1.2	Highlights .....	13
1.3	What's New .....	13
1.4	Included Items .....	13
1.5	The Low Pin Count Board .....	14
1.6	Software Overview .....	15
1.7	Running the Demonstrations .....	15

### Chapter 2. PIC® MCU Architecture

2.1	Introduction .....	17
2.2	Core Basics .....	17
2.3	Data/Program Bus .....	20
2.4	Accumulator .....	20
2.5	Instructions .....	20
2.6	Byte .....	21
2.7	Bit .....	21
2.8	Literal .....	21
2.9	Control .....	22
2.10	Stack Level .....	25
2.11	Memory Organization .....	25
2.12	Program Memory .....	25
2.12.1	Flash Program Memory .....	25
2.12.2	Configuration Words .....	25
2.12.3	Device ID .....	25
2.12.4	Revision ID .....	26
2.12.5	User ID .....	27
2.13	Data Memory .....	27
2.13.1	Core Registers .....	28
2.13.2	Special Function Registers .....	28
2.13.3	General Purpose RAM .....	28
2.13.4	Common RAM .....	28
2.14	Banks .....	28
2.15	Data EEPROM Memory .....	34
2.16	Programming Basics .....	34
2.16.1	MPASM™ Assembler Operation .....	34
2.16.2	XC8 Operation .....	34
2.16.3	Numbers in the Assembler .....	36
2.16.4	Numbers in the XC8 Compiler .....	36

# PICKit™ 3 STARTER KIT USER'S GUIDE

---

2.17	MPASM Assembler Directives .....	36
2.17.1	Banksel .....	36
2.17.2	cblock .....	36
2.17.3	Org (addr) .....	37
2.17.4	End .....	37
2.17.5	Errorlevel .....	37
2.17.6	#include .....	37

## Chapter 3. Lessons

3.1	Lessons .....	40
3.2	Lesson 1: Hello World (Turn on an LED) .....	41
3.2.1	Introduction .....	41
3.2.2	Hardware Effects .....	41
3.2.3	Summary .....	41
3.2.4	New Registers .....	41
3.2.5	New Instructions .....	42
3.2.6	Assembly .....	43
3.2.7	C Language .....	45
3.3	Lesson 2: Blink .....	46
3.3.1	Introduction .....	46
3.3.2	Hardware Effects .....	46
3.3.3	Summary .....	46
3.3.4	New Registers .....	46
3.3.5	New Instructions .....	46
3.3.6	Assembly .....	47
3.3.7	C Language .....	49
3.4	Lesson 3: Rotate .....	50
3.4.1	Introduction .....	50
3.4.2	Hardware Effects .....	50
3.4.3	Summary .....	50
3.4.4	New Registers .....	50
3.4.5	New Instructions .....	50
3.4.6	Assembly .....	51
3.4.7	C Language .....	53
3.5	Lesson 4: Analog-to-Digital Conversion .....	54
3.5.1	Introduction .....	54
3.5.2	Hardware Effects .....	54
3.5.3	Summary .....	54
3.5.4	New Registers .....	54
3.5.5	New Instructions .....	56
3.5.6	Assembly .....	57
3.5.7	C Language .....	57
3.6	Lesson 5: Variable Speed Rotate .....	59
3.6.1	Introduction .....	59
3.6.2	Hardware Effects .....	59
3.6.3	Summary .....	59
3.6.4	New Registers .....	59
3.6.5	New Instructions .....	59
3.6.6	Assembly .....	61
3.6.7	C Language .....	61

3.7	Lesson 6: Debounce .....	62
	3.7.1 Introduction .....	62
	3.7.2 Hardware Effects .....	62
	3.7.3 Summary .....	63
	3.7.4 New Registers .....	63
	3.7.5 New Instructions .....	63
	3.7.6 Assembly .....	63
	3.7.7 PIC18 .....	63
	3.7.8 C Language .....	63
3.8	Lesson 7: Reversible Variable Speed Rotate .....	64
	3.8.1 Introduction .....	64
	3.8.2 Hardware Effects .....	64
	3.8.3 Summary .....	64
	3.8.4 New Registers .....	65
	3.8.5 New Instructions .....	65
	3.8.6 Assembly .....	65
	3.8.7 C Language .....	66
3.9	Lesson 8: Pulse-Width Modulation (PWM) .....	67
	3.9.1 Introduction .....	67
	3.9.2 Hardware Effects .....	67
	3.9.3 Summary .....	67
	3.9.4 New Registers .....	67
	3.9.5 Assembly .....	70
3.10	Lesson 9: Timer0 .....	71
	3.10.1 Introduction .....	71
	3.10.2 Hardware Effects .....	71
	3.10.3 Summary .....	71
	3.10.4 New Registers .....	71
	3.10.5 Assembly .....	72
	3.10.6 C Language .....	72
3.11	Lesson 10: Interrupts and Pull-ups .....	73
	3.11.1 Introduction .....	73
	3.11.2 Hardware Effects .....	73
	3.11.3 Summary .....	73
	3.11.4 New Registers .....	75
	3.11.5 New Instructions .....	76
	3.11.6 Assembly .....	76
	3.11.7 C Language .....	77
3.12	Lesson 11: Indirect Addressing .....	78
	3.12.1 Introduction .....	78
	3.12.2 Hardware Effects .....	78
	3.12.3 Summary .....	78
	3.12.4 New Registers .....	80
	3.12.5 New Instructions .....	80
	3.12.6 Assembly Language .....	81
	3.12.7 C language .....	82
3.13	Lesson 12: Look-up Table .....	83
	3.13.1 Intro .....	83
	3.13.2 Hardware Effects .....	83
	3.13.3 Summary .....	83

# PICKit™ 3 STARTER KIT USER'S GUIDE

---

3.13.4	New Registers .....	83
3.13.5	New Registers .....	85
3.13.6	New Instructions: .....	86
3.13.7	Assembly Language .....	87
3.13.8	C Language .....	90
3.14	Lesson 13: EEPROM .....	92
3.14.1	Introduction .....	92
3.14.2	Hardware Effects .....	92
3.14.3	Summary .....	92
3.14.4	New Registers .....	93
3.14.5	New Instructions .....	93
3.14.6	Assembly Language .....	93
3.14.7	C Language .....	94

## Appendix A. Block Diagram and MPLAB® X Shortcuts

A.1	Useful MPLAB® X Shortcuts .....	96
A.2	Finding Register Names .....	96
A.3	PIC MCU Assembly Coding Practices: .....	96



# MICROCHIP PICKit™ 3 STARTER KIT USER'S GUIDE

## Preface

### NOTICE TO CUSTOMERS

All documentation becomes dated, and this manual is no exception. Microchip tools and documentation are constantly evolving to meet customer needs, so some actual dialogs and/or tool descriptions may differ from those in this document. Please refer to our web site ([www.microchip.com](http://www.microchip.com)) to obtain the latest documentation available.

Documents are identified with a “DS” number. This number is located on the bottom of each page, in front of the page number. The numbering convention for the DS number is “DSXXXXA”, where “XXXX” is the document number and “A” is the revision level of the document.

For the most up-to-date information on development tools, see the MPLAB® IDE online help. Select the Help menu, and then Topics to open a list of available online help files.

### INTRODUCTION

This chapter contains general information that will be useful to know before using the PICKit™ 3 Starter Kit User's Guide. Items discussed in this chapter include:

- Document Layout
- Conventions Used in this Guide
- Warranty Registration
- Recommended Reading
- The Microchip Web Site
- Development Systems Customer Change Notification Service
- Customer Support
- Document Revision History

### DOCUMENT LAYOUT

This document describes how to use the PICKit™ 3 Starter Kit User's Guide as a development tool to emulate and debug firmware on a target board. The manual layout is as follows:

- **Section Chapter 1. “Overview”**
- **Section Chapter 2. “PIC® MCU Architecture”**
- **Section Chapter 3. “Lessons”**
- **Appendix A. “Block Diagram and MPLAB® X Shortcuts”**

# PICKit™ 3 Starter Kit User's Guide

## CONVENTIONS USED IN THIS GUIDE

This manual uses the following documentation conventions:

### DOCUMENTATION CONVENTIONS

Description	Represents	Examples
<b>Arial font:</b>		
Italic characters	Referenced books	<i>MPLAB® IDE User's Guide</i>
	Emphasized text	...is the <i>only</i> compiler...
Initial caps	A window	the Output window
	A dialog	the Settings dialog
	A menu selection	select Enable Programmer
Quotes	A field name in a window or dialog	"Save project before build"
Underlined, italic text with right angle bracket	A menu path	<u><i>File&gt;Save</i></u>
Bold characters	A dialog button	Click <b>OK</b>
	A tab	Click the <b>Power</b> tab
N'Rnnnn	A number in verilog format, where N is the total number of digits, R is the radix and n is a digit.	4'b0010, 2'hF1
Text in angle brackets < >	A key on the keyboard	Press <Enter>, <F1>
<b>Courier New font:</b>		
Plain Courier New	Sample source code	#define START
	Filenames	autoexec.bat
	File paths	c:\mcc18\h
	Keywords	_asm, _endasm, static
	Command-line options	-Opa+, -Opa-
	Bit values	0, 1
	Constants	0xFF, 'A'
Italic Courier New	A variable argument	<i>file.o</i> , where <i>file</i> can be any valid filename
Square brackets [ ]	Optional arguments	mcc18 [options] <i>file</i> [options]
Curly brackets and pipe character: {   }	Choice of mutually exclusive arguments; an OR selection	errorlevel {0 1}
Ellipses...	Replaces repeated text	var_name [, var_name...]
	Represents code supplied by user	void main (void) { ... }

## WARRANTY REGISTRATION

Please complete the enclosed Warranty Registration Card and mail it promptly. Sending in the Warranty Registration Card entitles users to receive new product updates. Interim software releases are available at the Microchip web site.

## RECOMMENDED READING

This user's guide describes how to use the PICkit™ 3 Starter Kit User's Guide. Other useful documents are listed below. The following Microchip documents are available and recommended as supplemental reference resources.

### **Readme for PICkit™ 3 Starter Kit User's Guide**

For the latest information on using PICkit™ 3 Starter Kit User's Guide, read the "Readme for PICkit™ 3 Starter Kit Board User's Guide.txt" file (an ASCII text file) in the Readmes subdirectory of the MPLAB IDE installation directory. The Readme file contains update information and known issues that may not be included in this user's guide.

### **PIC16(L)F1825/29 Data Sheet (DS41440)**

This data sheet summarizes the features of the PIC16F1829.

### **PIC18(L)F1XK22 Data Sheet (DS41365)**

This data sheet summarizes the features of the PIC18F14K22.

### **Readme Files**

For the latest information on using other tools, read the tool-specific Readme files in the Readmes subdirectory of the MPLAB IDE installation directory. The Readme files contain update information and known issues that may not be included in this user's guide.

# PICKit™ 3 Starter Kit User's Guide

---

## THE MICROCHIP WEB SITE

Microchip provides online support via our web site at [www.microchip.com](http://www.microchip.com). This web site is used as a means to make files and information easily available to customers. Accessible by using your favorite Internet browser, the web site contains the following information:

- **Product Support** – Data sheets and errata, application notes and sample programs, design resources, user's guides and hardware support documents, latest software releases and archived software
- **General Technical Support** – Frequently Asked Questions (FAQs), technical support requests, online discussion groups, Microchip consultant program member listing
- **Business of Microchip** – Product selector and ordering guides, latest Microchip press releases, listing of seminars and events, listings of Microchip sales offices, distributors and factory representatives

## DEVELOPMENT SYSTEMS CUSTOMER CHANGE NOTIFICATION SERVICE

Microchip's customer notification service helps keep customers current on Microchip products. Subscribers will receive e-mail notification whenever there are changes, updates, revisions or errata related to a specified product family or development tool of interest.

To register, access the Microchip web site at [www.microchip.com](http://www.microchip.com), click on Customer Change Notification and follow the registration instructions.

The Development Systems product group categories are:

- **Compilers** – The latest information on Microchip C compilers and other language tools. These include the HI-TECH C® C16, MPLAB C18 and MPLAB C30 C compilers; MPASM™ and MPLAB ASM30 assemblers; MPLINK™ and MPLAB LINK30 object linkers; and MPLIB™ and MPLAB LIB30 object librarians.
- **In-Circuit Debuggers** – The latest information on the Microchip in-circuit debugger, MPLAB ICD 2, MPLAB ICD 3, PICKit™ 3.
- **MPLAB® IDE** – The latest information on Microchip MPLAB IDE, the Windows® Integrated Development Environment for development systems tools. This list is focused on the MPLAB IDE, MPLAB SIM simulator, MPLAB IDE Project Manager and general editing and debugging features.
- **Programmers** – The latest information on Microchip programmers. These include the MPLAB PM3 device programmers and PICKit™ 3 development programmers.

## CUSTOMER SUPPORT

Users of Microchip products can receive assistance through several channels:

- Distributor or Representative
- Local Sales Office
- Field Application Engineer (FAE)
- Technical Support

Customers should contact their distributor, representative or field application engineer (FAE) for support. Local sales offices are also available to help customers. A listing of sales offices and locations is included in the back of this document.

Technical support is available through the web site at: <http://support.microchip.com>

## DOCUMENT REVISION HISTORY

### Revision A (October 2012)

- Initial Release of this Document.

# PICKit™ 3 Starter Kit User's Guide

---

NOTES:



---

---

## Chapter 1. Overview

---

---

### 1.1 INTRODUCTION

This chapter introduces the hardware that is included in the kit, as well as a quick start to downloading and installing the accompanying software.

### 1.2 HIGHLIGHTS

This chapter discusses:

- What's New
- Included Items
- The Low Pin Count (LPC) Board Hardware
- Software Overview
- Running the Demonstrations

### 1.3 WHAT'S NEW

This kit is an update to the PICKit™ 2 Starter Kit. Modifications to the previous LPC board (DM164120-1) were made so that the full functionality of the code can be debugged without the need of a debug header. The software has also been rewritten to accommodate new technologies. The following is a list of new features:

1. Software is in both the 'C' and assembler language
2. Extension of the number of lessons and modules covered
3. MPLAB® X support as well as the older MPLAB® 8
4. New PIC16 enhanced mid-range and PIC18 routines
5. Uses the universal XC8 compiler

The following is a list of hardware changes to the LPC board:

1. Potentiometer connected to RA4 (formerly to RA0)
2. Switch connected to RA2 (formerly to RA3)

This new LPC board is still backwards compatible. Bridging the old pins to the new pins will restore functionality.

### 1.4 INCLUDED ITEMS

1. 1x PICKit 3 Programmer
2. 1x Micro USB cable
3. 1x LPC Board (Part Number : DM164130-9)
4. 1x PIC16F1829-I/P
5. 1x PIC18F14K22 -I/P

The 13 lessons can be downloaded from the web.

The PIC16F1829 is a new enhanced mid-range device, which supports more features than the older mid-range PIC16 parts.

# PICkit™ 3 Starter Kit User's Guide

The software associated with the kit supports the PIC16F1829 and PIC18F14K22. The software is intended to run on these two devices, although the software can be easily ported to other devices.

## 1.5 THE LOW PIN COUNT BOARD

Support for 18-pin devices requires some board modifications. 14- and 20-pin PIC devices will have full access to all of the human interface devices. If an 8-pin part is used, then the LEDs will have to be bridged to the necessary pins on the PIC MCU. The switch and potentiometer are already connected to pins that are supported by an 8-pin device. The board provides holes next to the LEDs that can be easily soldered to in order to create any desired hardware changes.

The board is programmable by an In-Circuit Serial Programmer™ (ICSP™), such as a PICkit™ programmer. The board should be supplied with 5V. Figure 1-1 shows the LPC Demo Board.

**FIGURE 1-1: DEMO BOARD HARDWARE LAYOUT**

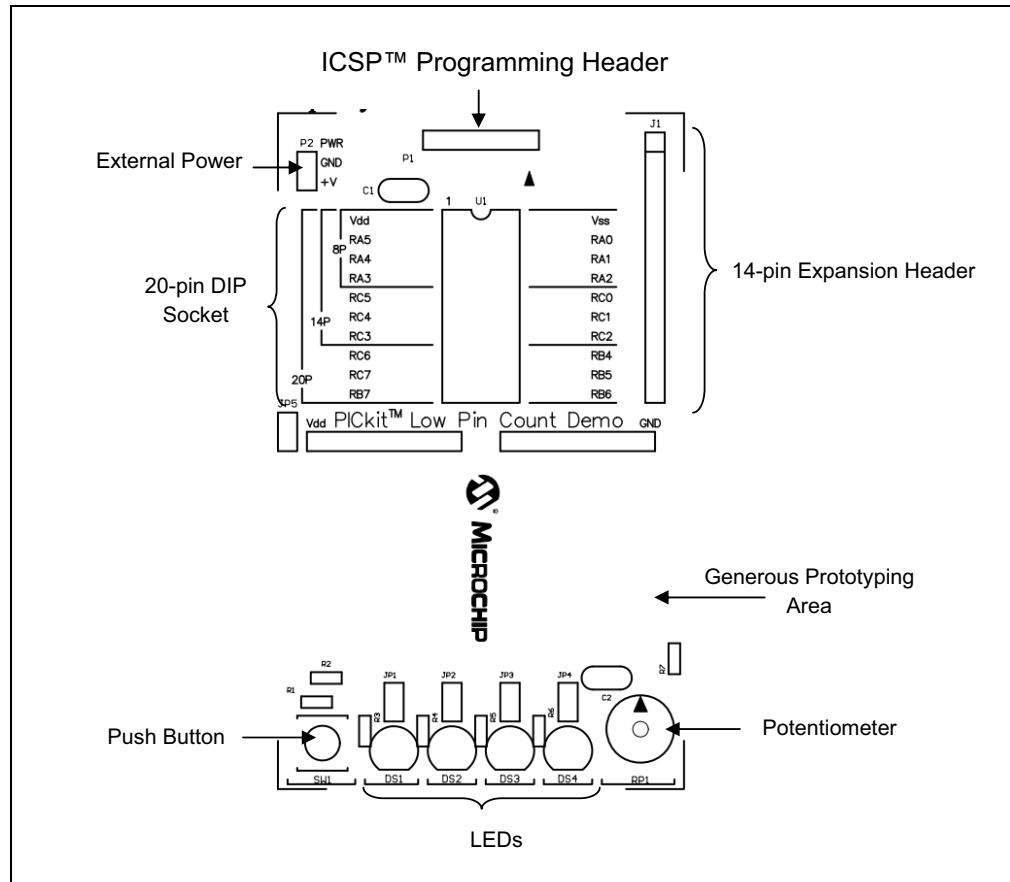

Table 1-1 lists the components that are connected to the two PIC devices that come with the board.

**TABLE 1-1: PIN ASSIGNMENTS**

Device	LEDs <DS4:DS1>	Switch – SW1	Potentiometer – RP1
PIC16F1829	<RC4:RC0>	RA2	RA4
PIC18F14K22	<RC4:RC0>	RA2	RA4

## 1.6 SOFTWARE OVERVIEW

This guide will assume that the reader has a basic knowledge of electronics. The reader does not need to have any programming experience with a PIC MCU before reading, although a basic knowledge of programming and what the difference between a bit and byte will help.

The software is written in both assembly and 'C' in the MPLAB X and MPLAB 8 integrated design environment (IDE). The assembly version is more complex and requires more lines of code, however it is closely tied to the PIC device's hardware and the reader will gain a much better understanding by doing these lessons in parallel with the 'C' routines. The 'C' programming language is a higher level language assembly, hence it provides the reader with an easier to read flow of the program. Each lesson has both versions and are functionally equivalent.

It is recommended that the lessons be followed sequentially, as presented, since most of the lessons build up on one another. Each new program will introduce a new peripheral or concept. This guide is not intended to be read without following along in the code.

The PIC18 and enhanced PIC16 programs will be presented side-by-side and their differences and similarities explained.

## 1.7 RUNNING THE DEMONSTRATIONS

The board comes preprogrammed with a lesson. To use this program, either apply 5V to the power header (P2), or connect a programmer to the programmer header (P1) and apply 5V through the programmer in the IDE. The demo program will blink the four red LEDs in succession. Press the push button (SW1), and the sequence will reverse. Rotate the potentiometer (RP1), and the light sequence will blink at a different rate. This demo program is developed through the first seven lessons in this guide.

# PICkit™ 3 Starter Kit User's Guide

---

NOTES:

## Chapter 2. PIC® MCU Architecture

### 2.1 INTRODUCTION

This chapter describes the architecture of the enhanced mid-range PIC16F1829 (DS41440), as well as the PIC18 (DS41365).

### 2.2 CORE BASICS

Enhanced PIC16 and PIC18 devices use a modified Harvard architecture, meaning the code memory and data memory are independent. This allows faster execution because code instructions and data can be accessed simultaneously. The subsequent instruction is fetched while decoding and executing the current instruction. In [Figure 2-1](#) and [Figure 2-3](#), the reader should notice the separate lines for data bus and program bus. This guide will cover nearly all of the registers and modules as seen in the following figures. The following block diagrams should be referenced while each lesson is being performed in order to understand the interactions.

**FIGURE 2-1: SIMPLIFIED ENHANCED MID-RANGE PIC® MCU BLOCK DIAGRAM**

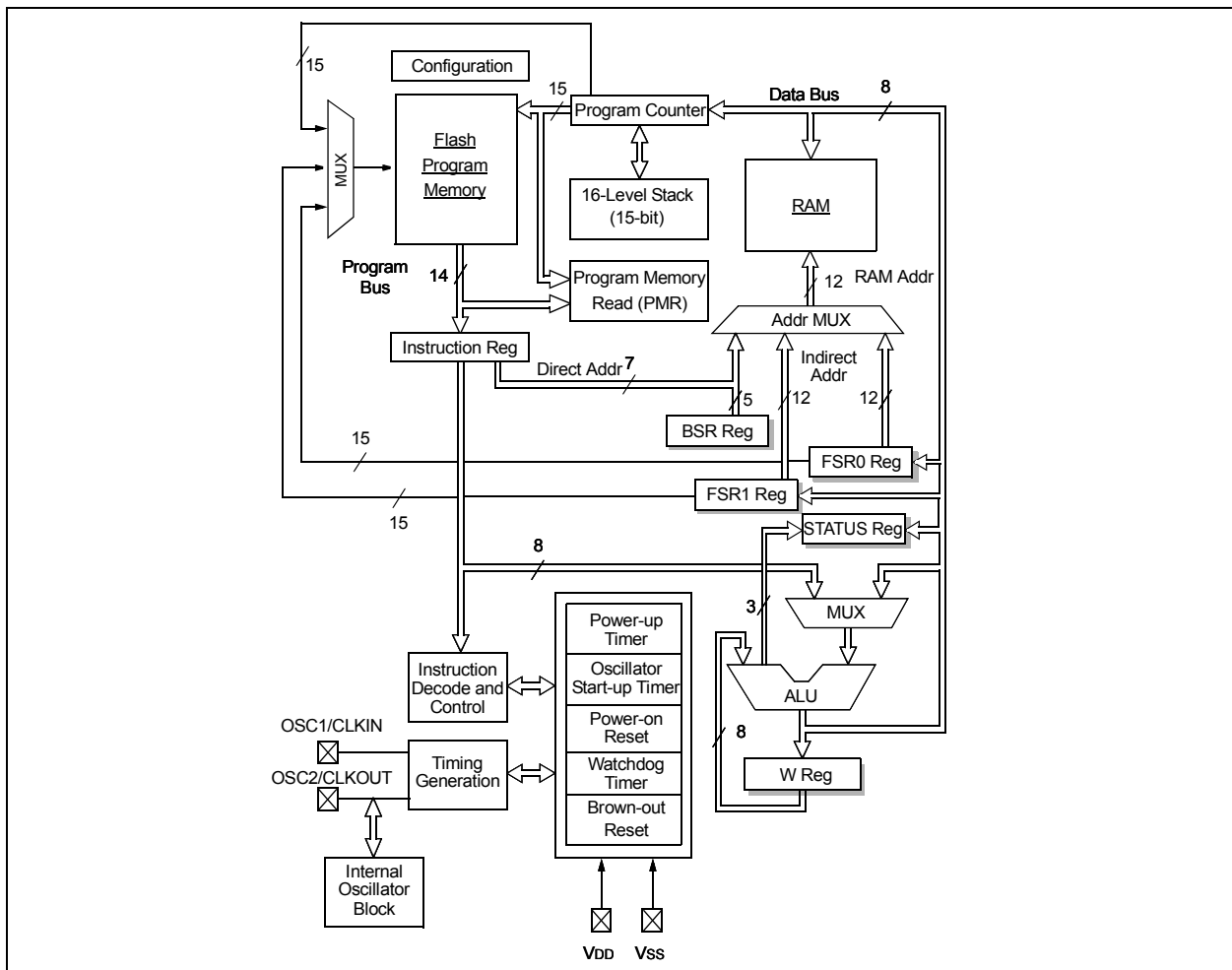

# PICKit™ 3 Starter Kit User's Guide

**FIGURE 2-2: SIMPLIFIED ENHANCED MID-RANGE PIC® MCU DATA BLOCK DIAGRAM**

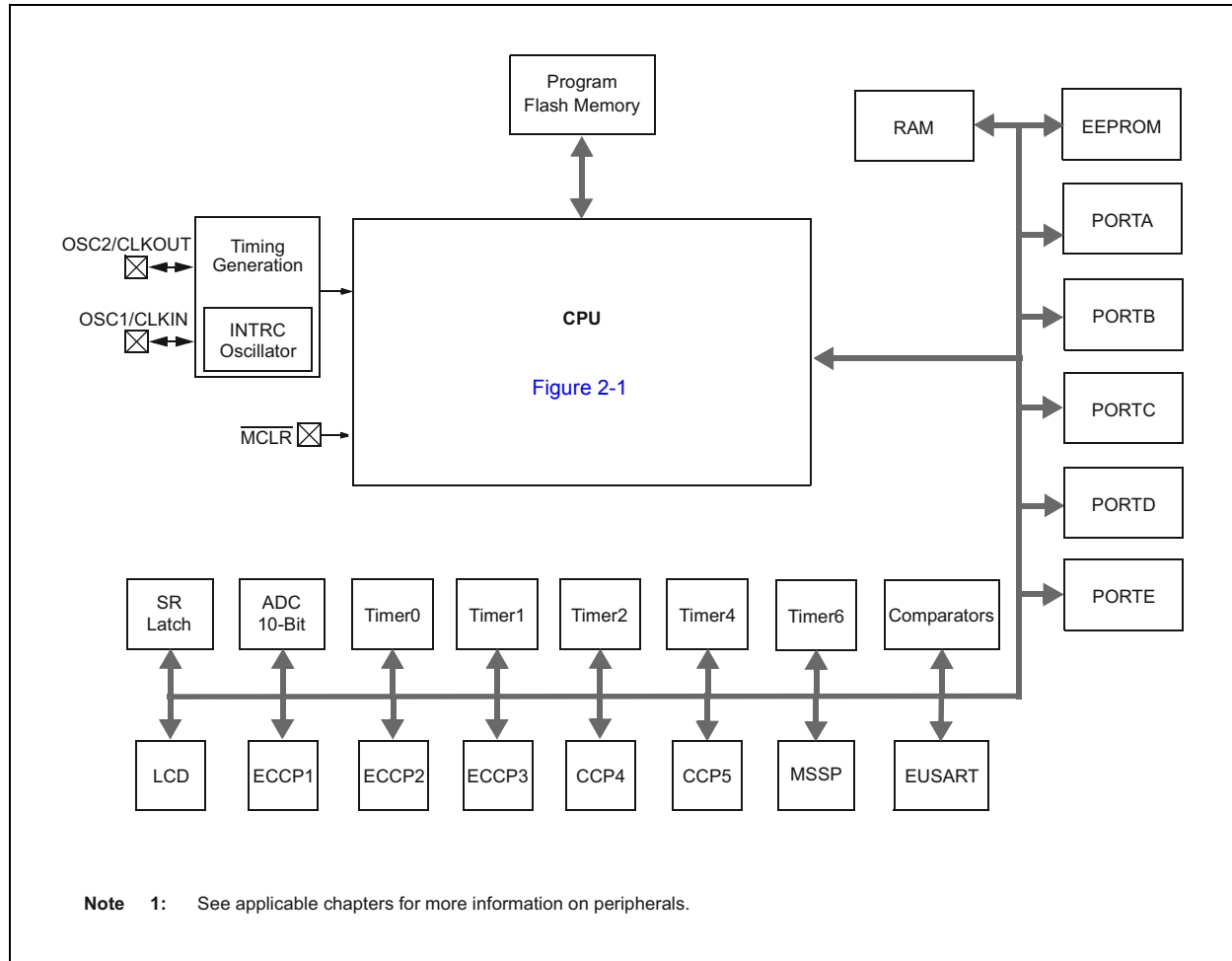

**FIGURE 2-3: SIMPLIFIED PIC18 BLOCK DIAGRAM**

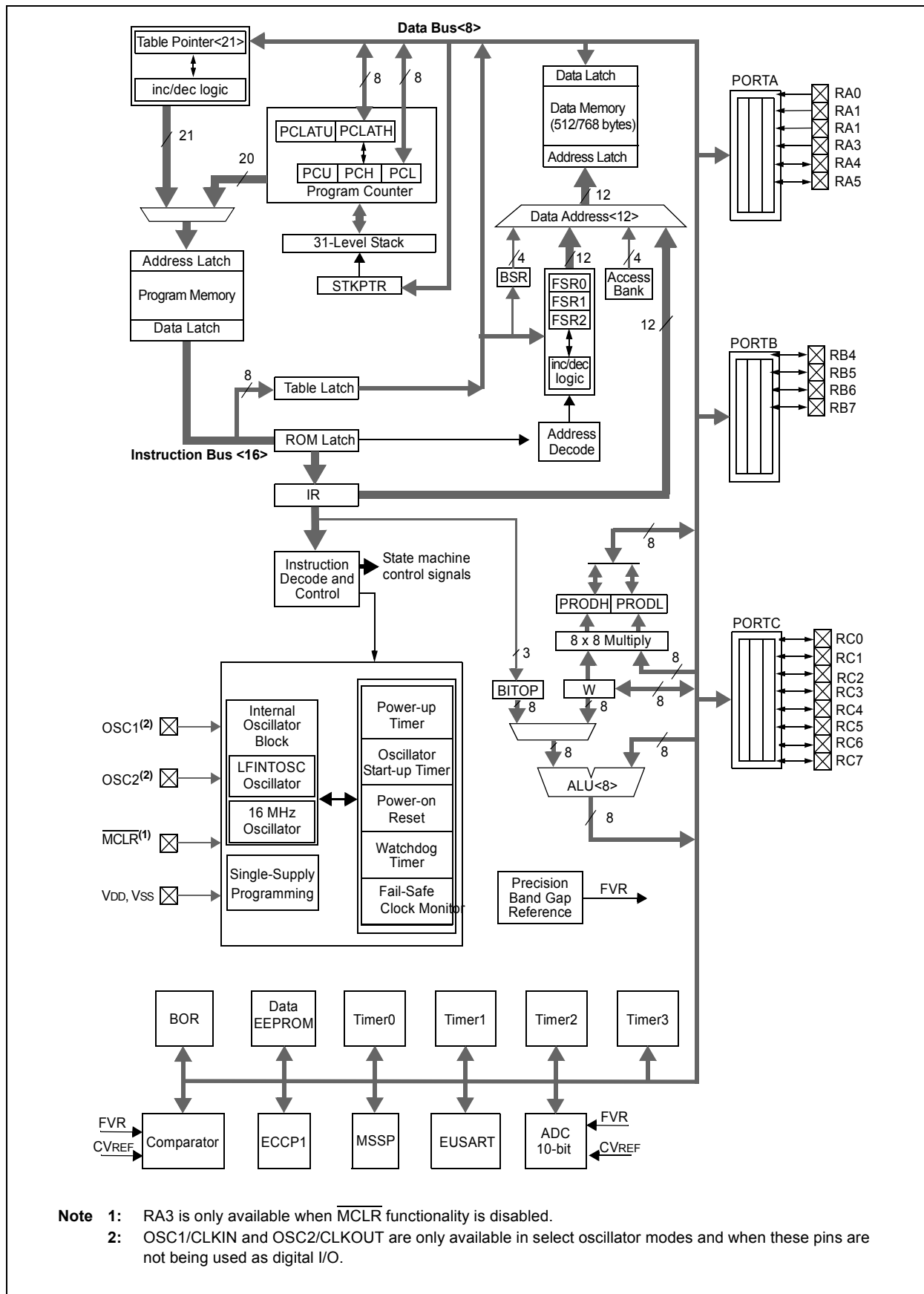

- Note 1:** RA3 is only available when  $\overline{\text{MCLR}}$  functionality is disabled.  
**Note 2:** OSC1/CLKIN and OSC2/CLKOUT are only available in select oscillator modes and when these pins are not being used as digital I/O.

# PICkit™ 3 Starter Kit User's Guide

---

## 2.3 DATA/PROGRAM BUS

The data bus is connected to the outside world via port pins, as well as all of the peripheral registers (timers, ADC, PWM). The program bus connects to the Flash memory where the program is stored. This is where assembled code is programmed to.

## 2.4 ACCUMULATOR

There is only one accumulator – the working register (WREG). The accumulator handles all data bus related tasks, such as mathematical operations. The ALU only deals with 8-bit sized data – hence the categorical names of 8/16/32-bit micros.

## 2.5 INSTRUCTIONS

Instructions tell what the PIC device should do, whether it is shifting a few bits or jumping to a new line in code. They form the very essence of each program in program memory. All enhanced mid-range PIC devices have only 49 instructions. The PIC18 has 75 available instructions. Since there are very few instructions needed to learn, the PIC device can be referred to as a “reduced instruction set computing”, or RISC, processor.

Each instruction will be explained in detail as they are introduced in each lesson. For now, the basis of what makes up each instruction will be explained.

One instruction cycle consists of four clock cycles. This means that if the PIC MCU is running at 4 MHz, each instruction will take one microsecond, as seen in [Equation 2-1](#).

### EQUATION 2-1: INSTRUCTION TIME

$$T(\text{clock cycle}) = \frac{1}{F_{OSC}}$$
$$4 * T = \frac{4}{F_{OSC}} = \frac{4}{4 \text{ MHz}} = 1 \mu s$$

All instructions are executed in a single instruction cycle, unless a conditional test is true, or the program counter (PC) is changed. In these cases, the execution takes two instruction cycles, with the additional instruction cycle executed as a `NOOP` (do nothing), see [Example 2-1](#).

### EXAMPLE 2-1:

```
BTFSF    PORTA, RA0
```

This takes two instruction cycles only if pin RA0 is set (active-high), since the skip operation affects the PC.

The PIC18 has a larger word size than the enhanced PIC16 architecture. The PIC18 has a 16-bit wide word containing the operation code (opcode) and all required operands. The enhanced PIC16 has a 14-bit wide word. An opcode is interpreted by the processor and is unique to each instruction.

The opcodes are broken into four formats:

1. Byte oriented
2. Bit oriented
3. Literal
4. Control

## 2.6 BYTE

All byte instructions on the enhanced PIC16 contain a 6-bit opcode, 7-bit file address, and a destination bit. All PIC18 byte instructions contain a 6-bit opcode, 8-bit file address, a destination bit, and a RAM access bit. The sum of all the bit field sizes confirms that the PIC16 enhanced core does indeed have a 14-bit wide word size for instructions. Likewise, the same can be seen for the PIC18 for its 16-bit wide word length.

The RAM access bit (a) on the PIC18 is set when the user wishes to use the Bank Select Register (BSR) for manually selecting the bank. The PIC16 user will always need to make sure that they are in the correct bank by using the 'banksel' directive. This is explained in the first few lessons.

The destination bit (d) specifies whether the result will be stored in WREG or back in the original file register. When 'd' is zero, the result is placed in the WREG register. Otherwise, the result is placed in the file register.

The file register (f) specifies which register to use. This can be a Special Function Register (SFR) or General Purpose Register (GPR).

### EXAMPLE 2-2:

```
ADDWF data, f
```

This adds the contents of WREG and data, with the result being saved back to the file register data.

The PIC18 can move data from one file register directly to another file register, circumventing the WREG. All file moves in the enhanced PIC16 architecture must go through the WREG.

## 2.7 BIT

Bit instructions operate on a specific bit within a file register. These instructions may set or clear a specific bit within a file register. They may also be used to test a specific bit within a file register. All bit instructions on the enhanced PIC16 contain a 4-bit opcode, 7-bit file address, and a 3-bit bit address. All PIC18 byte instructions contain a 4-bit opcode, 8-bit file address, 3-bit bit address and a RAM access bit.

### EXAMPLE 2-3:

```
BSF PORTA, RA0
```

This sets pin RA0 in the PORTA register.

## 2.8 LITERAL

Literal operations contain the data operand within the instruction. Both architectures use an 8-bit intermediate value. The rest of the bits are reserved for the opcode.

### EXAMPLE 2-4:

```
MOVLW 'A'
```

This moves the ASCII value of 'A' (0x41) into WREG.

## 2.9 CONTROL

Instructions that dictate what address the PC will select in program memory are called control instructions. This would include `call`, `goto`, and `branch`. Each has a unique word length. Please refer to the “**Instruction Set Summary**” chapter in any PIC device data sheet for more information.

**FIGURE 2-4: ENHANCED PIC16 GENERAL FORMAT FOR INSTRUCTIONS**

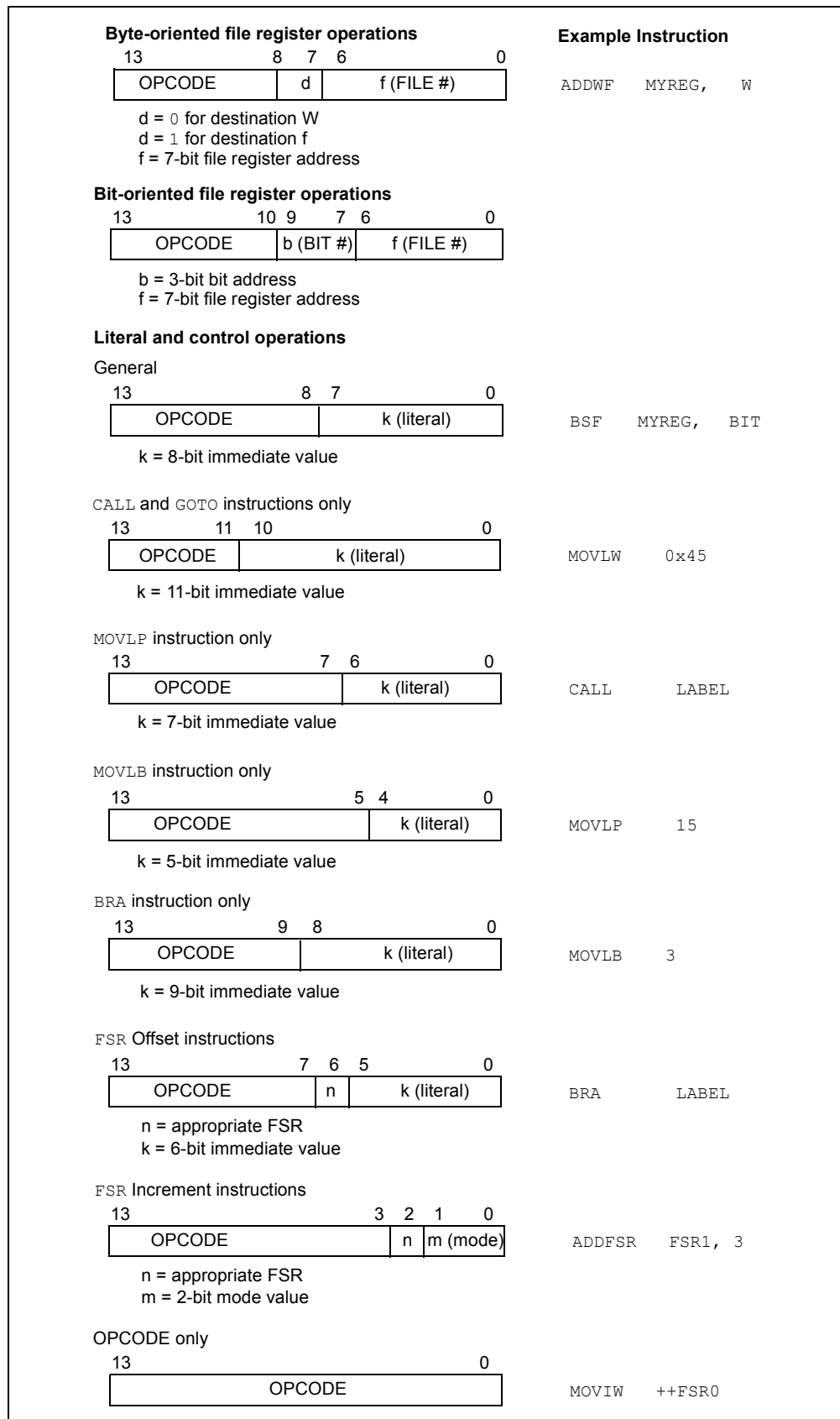

# PICkit™ 3 Starter Kit User's Guide

**FIGURE 2-5: PIC18 GENERAL FORMAT FOR INSTRUCTIONS**

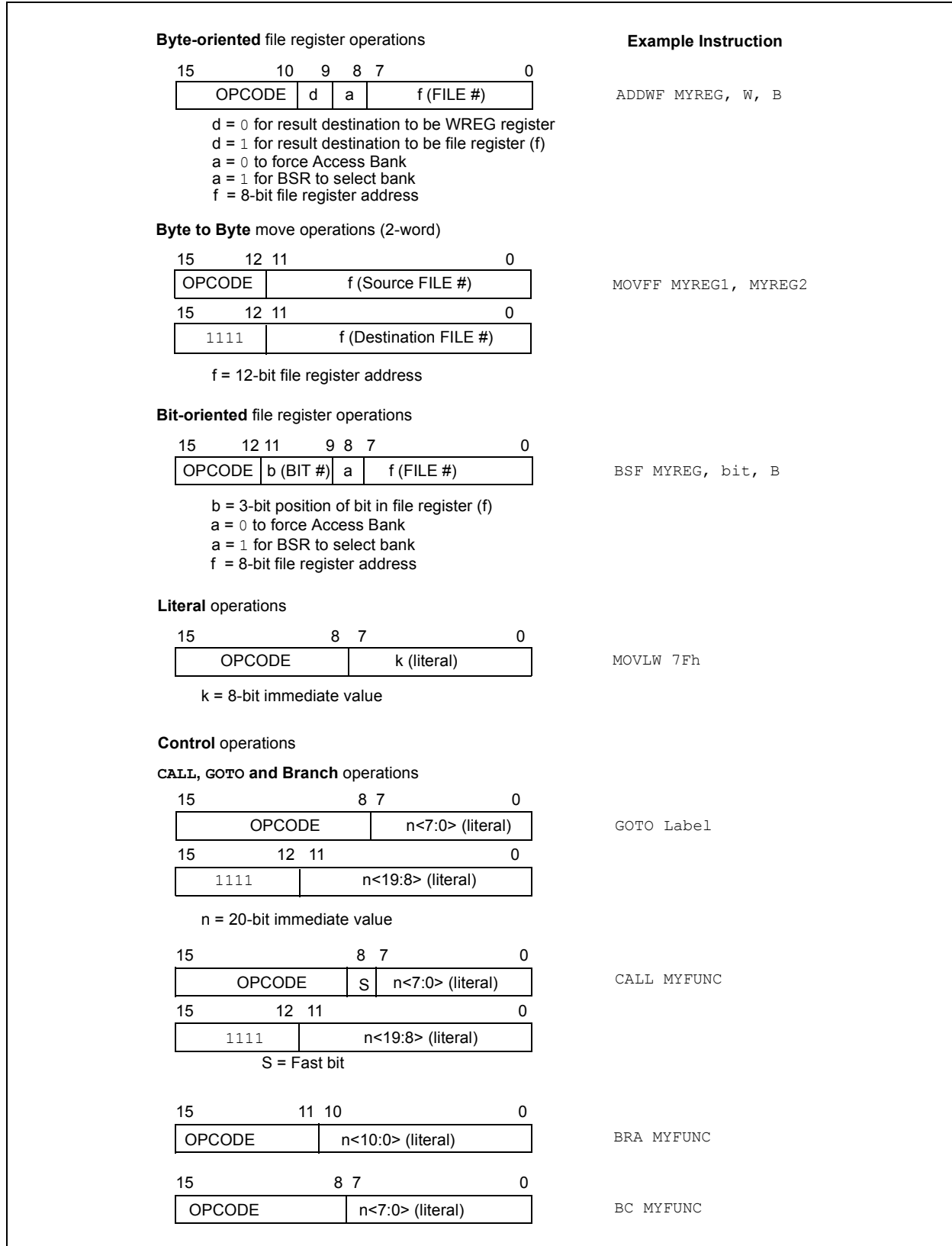

There are some subtle differences between the block diagrams in [Figure 2-1](#) and [Figure 2-3](#). This document will point out a few of the important ones.

## 2.10 STACK LEVEL

The PIC18 has a deeper stack level of 31, whereas the enhanced core has 16. A deeper stack allows the PIC device to make more calls in the software before returning to the original address where the first call was made.

A `call` or `goto` modifies the program counter to point to a different place in code. Without these, the code would execute from the top to the bottom. The lessons will show the significance of this.

The call stack is used to save the return address before going to a new position in program memory.

As a frame of reference, some of the baseline parts (PIC10/12) devices have a call stack that is only two levels deep. It is quite a challenge to create modular code with a limited stack depth.

## 2.11 MEMORY ORGANIZATION

There are three sections of memory in the PIC16 enhanced mid-range and PIC18 devices:

1. Program Memory
2. Data RAM
3. Data EEPROM

## 2.12 PROGRAM MEMORY

There are five sections of program memory:

1. Flash Program Memory
2. Configuration Words
3. Device ID
4. Revision ID
5. User ID

### 2.12.1 Flash Program Memory

All enhanced mid-range and PIC18 devices use Flash memory for programming. Flash allows the PIC device to be erased and written to hundreds of thousands of times.

### 2.12.2 Configuration Words

There are several Configuration Word bits, or fuses, that allow different configurations at run-time. Oscillator selections, memory protection, low-voltage detection, etc., are some examples of configuration options. Each device has different configuration options. Enhanced mid-range Configuration bits are read-only during code execution. PIC18 can read all and write most Configuration bits during code execution. The Configuration bits are programmed in a special way, as seen in the lesson source files.

### 2.12.3 Device ID

The Device ID contains the read-only manufacture's ID for the PIC MCU. The PIC16F1829 ID is stored in DEVICEID and the PIC18F14K22 is stored in DEVID1 and DEVID2.

# PICKit™ 3 Starter Kit User's Guide

## 2.12.4 Revision ID

There are five bits in each PIC MCU that indicate the silicon revision of the PIC device. These bits are read-only and found in the DEVID register. There are usually multiple revisions of silicon for each PIC device. The errata document, which points out any errors and their temporary work-arounds, should be read alongside the data sheet.

The PIC18 has a program bus that is 21 bits wide, whereas the enhanced core is only 15 bits wide. A larger program bus infers that the program memory is larger, since it allows the core to locate a higher address value. The enhanced core program counter is capable of addressing 32K x 14 program memory space as seen in [Figure 2-6](#).

**FIGURE 2-6: ENHANCED MID-RANGE PROGRAM MEMORY MAP AND CALL STACK**

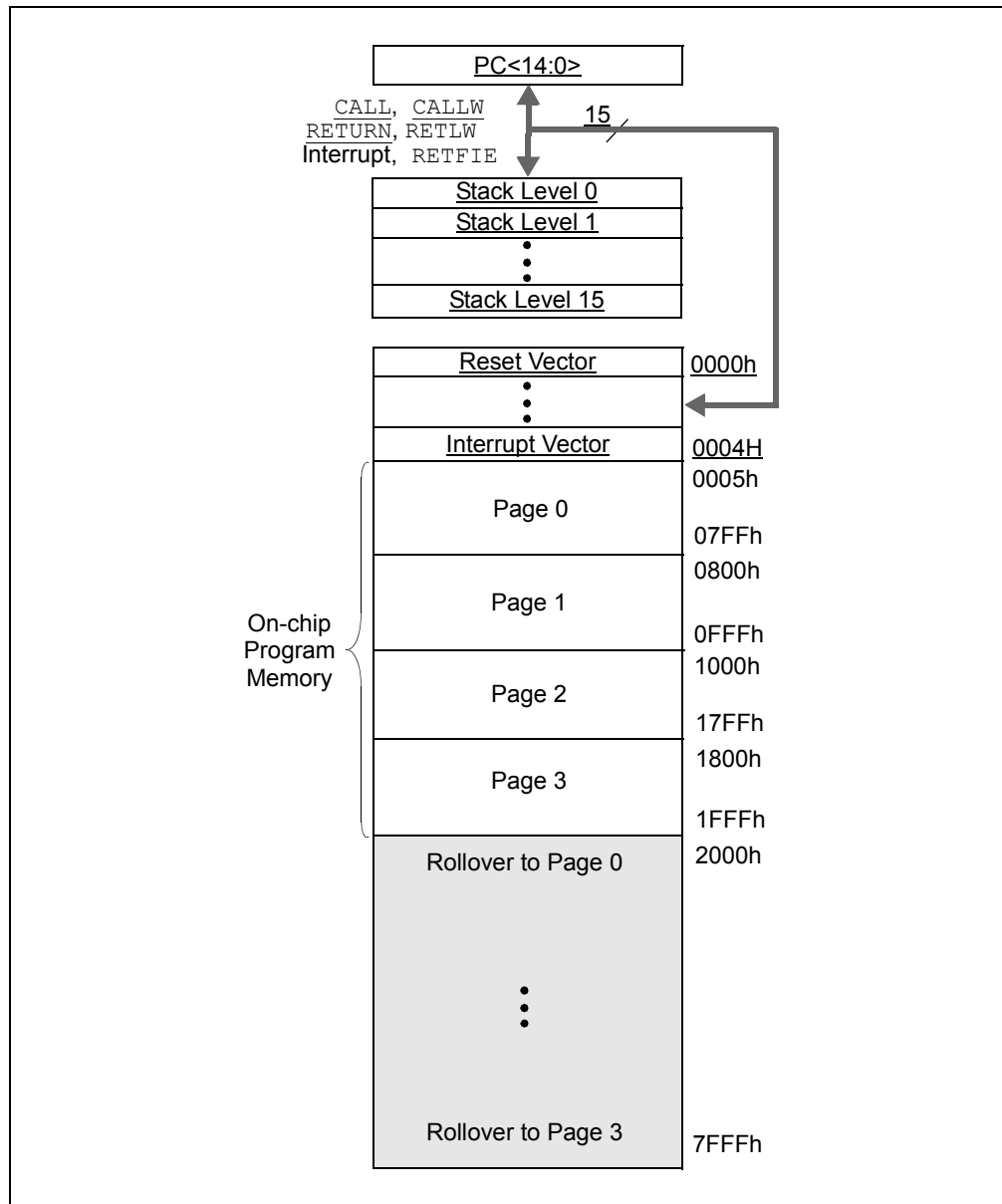

PIC18 devices are capable of addressing a 2-Mbyte program memory space, as seen in [Figure 2-7](#). PIC18 devices also have two interrupt vectors, whereas the enhanced PIC devices only have one. A stark difference is that the PIC18 has no concept of pages, whereas the enhanced core has its program memory split into different pages.

Changing pages is necessary in the enhanced core when changing execution from one page to another. None of the lessons for the enhanced PIC16 occupy more than one page and, therefore, page changes are not necessary. If the code does overflow into another page, the assembler will give a warning, indicating that a `pagesel` may be required.

**FIGURE 2-7: PIC18 PROGRAM MEMORY MAP AND CALL STACK**

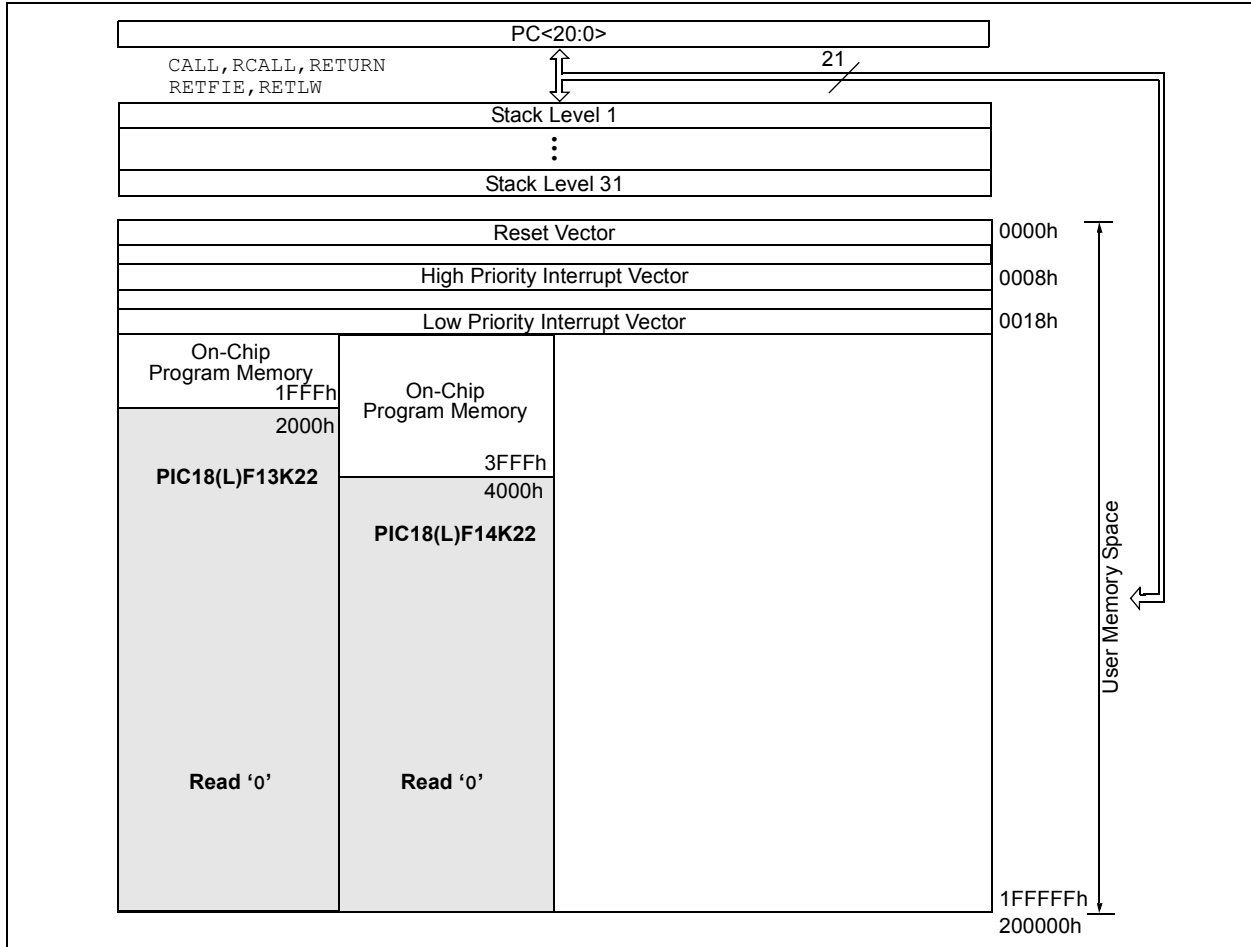

## 2.12.5 User ID

These four memory locations are designated as ID locations where the programmer can store checksum or other code identification numbers. These are readable and writable during normal execution.

## 2.13 DATA MEMORY

The data memory layout of the two device families is perhaps the most significant. Data memory on both families can be split into four types:

1. Core Registers
2. Special Function Registers
3. General Purpose RAM
4. Common RAM

## 2.13.1 Core Registers

The core registers contain the registers that directly affect the basic operation of the PIC device, repeated at the top of every data memory bank. Here are three examples of the 12 core registers:

1. STATUS
2. WREG
3. INTCON

The STATUS register contains the arithmetic status of the ALU. The WREG register is used to move bits in and out of registers. The INTCON register contains the various enable and flag bits that would cause the PIC MCU to jump to the Interrupt Vector.

## 2.13.2 Special Function Registers

The Special Function Registers provide access to the peripheral functions in the device. The Special Function Registers occupy 20 bytes immediately after the core registers of every data memory bank (addresses x0Ch/x8Ch through x1Fh/x9Fh) on the enhanced mid-range core. The PIC18 enhanced core has all of its SFRs in Access RAM, which is discussed in **Section 2.14 “Banks”**.

## 2.13.3 General Purpose RAM

GPRs are used for data storage and scratchpad operations in the user's application. Think of this as RAM that can be used for your program, but the correct bank must be selected before using. For the enhanced mid-range PIC devices, there are up to 80 bytes of GPR that follow immediately after the SFR space in each data memory bank.

## 2.13.4 Common RAM

There are 16 bytes of common RAM accessible from all banks in the enhanced core. The PIC18 architecture has something similar called Access RAM, which contains up to 96 bytes.

## 2.14 BANKS

The PIC18F14K22 data memory is divided into 16 banks that contain 256 bytes each. The PIC16F1829 data memory is partitioned in 32 memory banks with 128 bytes in each bank. For the PIC16 enhanced mid-range, each bank consists of:

1. 12 core registers
2. 20 Special Function Registers (SFR)
3. Up to 80 bytes of General Purpose RAM (GPR)
4. 16 bytes of shared RAM (accessible by any bank)

[Figure 2-8](#) shows the above information on the enhanced PIC16.

**FIGURE 2-8: ENHANCED MID-RANGE BANKED MEMORY PARTITIONING**

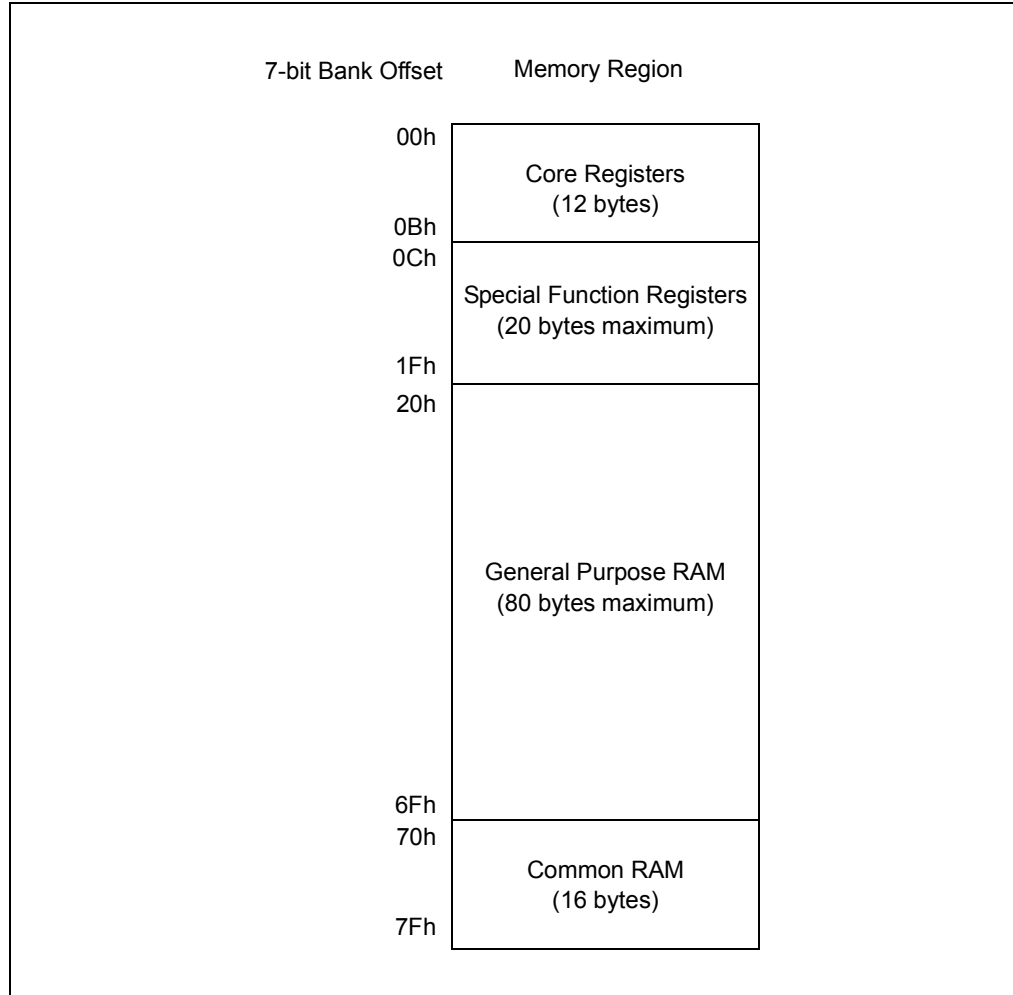

Addresses 70h-7Fh are shared by all of the banks. This is useful for storing a few bytes of RAM without the need to switch banks each time the byte is used. [Figure 2-9](#) shows the first eight banks on the PIC16F1829. Notice how the top 12 core registers are accessible from every bank, as are the 16 bytes of common RAM.

**FIGURE 2-9: PIC16F1829 MEMORY MAP – THE CORRECT BANK MUST BE SELECTED BEFORE WRITING/READING FROM A REGISTER**

BANK 0		BANK 1		BANK 2		BANK 3		BANK 4		BANK 5		BANK 6		BANK 7	
000h	INDF0	080h	INDF0	100h	INDF0	180h	INDF0	200h	INDF0	280h	INDF0	300h	INDF0	380h	INDF0
001h	INDF1	081h	INDF1	101h	INDF1	181h	INDF1	201h	INDF1	281h	INDF1	301h	INDF1	381h	INDF1
002h	PCL	082h	PCL	102h	PCL	182h	PCL	202h	PCL	282h	PCL	302h	PCL	382h	PCL
003h	STATUS	083h	STATUS	103h	STATUS	183h	STATUS	203h	STATUS	283h	STATUS	303h	STATUS	383h	STATUS
004h	FSR0L	084h	FSR0L	104h	FSR0L	184h	FSR0L	204h	FSR0L	284h	FSR0L	304h	FSR0L	384h	FSR0L
005h	FSR0H	085h	FSR0H	105h	FSR0H	185h	FSR0H	205h	FSR0H	285h	FSR0H	305h	FSR0H	385h	FSR0H
006h	FSR1L	086h	FSR1L	106h	FSR1L	186h	FSR1L	206h	FSR1L	286h	FSR1L	306h	FSR1L	386h	FSR1L
007h	FSR1H	087h	FSR1H	107h	FSR1H	187h	FSR1H	207h	FSR1H	287h	FSR1H	307h	FSR1H	387h	FSR1H
008h	BSR	088h	BSR	108h	BSR	188h	BSR	208h	BSR	288h	BSR	308h	BSR	388h	BSR
009h	WREG	089h	WREG	109h	WREG	189h	WREG	209h	WREG	289h	WREG	309h	WREG	389h	WREG
00Ah	PCLATH	08Ah	PCLATH	10Ah	PCLATH	18Ah	PCLATH	20Ah	PCLATH	28Ah	PCLATH	30Ah	PCLATH	38Ah	PCLATH
00Bh	INTCON	08Bh	INTCON	10Bh	INTCON	18Bh	INTCON	20Bh	INTCON	28Bh	INTCON	30Bh	INTCON	38Bh	INTCON
00Ch	PORTA	08Ch	TRISA	10Ch	LATA	18Ch	ANSELA	20Ch	WPUA	28Ch	—	30Ch	—	38Ch	INLVLA
00Dh	PORTB <sup>(1)</sup>	08Dh	TRISB <sup>(1)</sup>	10Dh	LATB <sup>(1)</sup>	18Dh	ANSELB <sup>(1)</sup>	20Dh	WPUB <sup>(1)</sup>	28Dh	—	30Dh	—	38Dh	INLVLB <sup>(1)</sup>
00Eh	PORTC	08Eh	TRISC	10Eh	LATC	18Eh	ANSELC	20Eh	WPUC	28Eh	—	30Eh	—	38Eh	INLVLC
00Fh	—	08Fh	—	10Fh	—	18Fh	—	20Fh	—	28Fh	—	30Fh	—	38Fh	—
010h	—	090h	—	110h	—	190h	—	210h	—	290h	—	310h	—	390h	—
011h	PIR1	091h	PIE1	111h	CM1CON0	191h	EEADR1	211h	SSP1BUF	291h	CCPR1L	311h	CCPR3L	391h	IOCAP
012h	PIR2	092h	PIE2	112h	CM1CON1	192h	EEADR2	212h	SSP1ADD	292h	CCPR1H	312h	CCPR3H	392h	IOCAN
013h	—	093h	—	113h	CM2CON0	193h	EEDATL	213h	SSP1MSK	293h	CCP1CON	313h	CCP3CON	393h	IOCAF
014h	—	094h	—	114h	CM2CON1	194h	EEDATH	214h	SSP1STAT	294h	PWM1CON	314h	—	394h	IOCBP <sup>(1)</sup>
015h	TMR0	095h	OPTION_REG	115h	CMOUT	195h	EECON1	215h	SSP1CON	295h	CCP1AS	315h	—	395h	IOCBN <sup>(1)</sup>
016h	TMR1L	096h	PCON	116h	BORCON	196h	EECON2	216h	SSP1CON2	296h	PSTR1CON	316h	—	396h	IOCBF <sup>(1)</sup>
017h	TMR1H	097h	WDTCON	117h	FVRCON	197h	—	217h	SSP1CON3	297h	—	317h	—	397h	—
018h	T1CON	098h	OSCTUNE	118h	DACCON0	198h	—	218h	—	298h	CCPR2L	318h	CCPR4L	398h	—
019h	T1GCON	099h	OSCCON	119h	DACCON1	199h	RCREG	219h	SSP2BUF <sup>(1)</sup>	299h	CCPR2H	319h	CCPR4H	399h	—
01Ah	TMR2	09Ah	OSCSTAT	11Ah	SRCON0	19Ah	TXREG	21Ah	SSP2ADD <sup>(1)</sup>	29Ah	CCP2CON	31Ah	CCP4CON	39Ah	CLKRCON
01Bh	PR2	09Bh	ADRESL	11Bh	SRCON1	19Bh	SPBRGL	21Bh	SSP2MSK <sup>(1)</sup>	29Bh	PWM2CON	31Bh	—	39Bh	—
01Ch	T2CON	09Ch	ADRESH	11Ch	—	19Ch	SPBRGH	21Ch	SSP2STAT <sup>(1)</sup>	29Ch	CCP2AS	31Ch	—	39Ch	MDCON
01Dh	—	09Dh	ADCON0	11Dh	APFCON0	19Dh	RCSTA	21Dh	SSP2CON <sup>(1)</sup>	29Dh	PSTR2CON	31Dh	—	39Dh	MDSRC
01Eh	CPSCON0	09Eh	ADCON1	11Eh	APFCON1	19Eh	TXSTA	21Eh	SSP2CON2 <sup>(1)</sup>	29Eh	CCPTMRS	31Eh	—	39Eh	MDCARL
01Fh	CPSCON1	09Fh	—	11Fh	—	19Fh	BAUDCON	21Fh	SSP2CON3 <sup>(1)</sup>	29Fh	—	31Fh	—	39Fh	MDCARH
020h	—	0A0h	—	120h	—	1A0h	—	220h	—	2A0h	—	320h	—	3A0h	—
06Fh	General Purpose Register 96 Bytes	0EFh	General Purpose Register 80 Bytes	16Fh	General Purpose Register 80 Bytes	1EFh	General Purpose Register 80 Bytes	26Fh	General Purpose Register 80 Bytes	2EFh	General Purpose Register 80 Bytes	36Fh	General Purpose Register 80 Bytes	3EFh	General Purpose Register 80 Bytes
070h		0F0h		170h		1F0h		270h		2F0h		370h		3F0h	
07Fh	—	0FFh	Accesses 70h – 7Fh	17Fh	Accesses 70h – 7Fh	1FFh	Accesses 70h – 7Fh	27Fh	Accesses 70h – 7Fh	2FFh	Accesses 70h – 7Fh	37Fh	Accesses 70h – 7Fh	3FFh	Accesses 70h – 7Fh

**Legend:** ■ = Unimplemented data memory locations, read as '0'.

**Note 1:** Available only on PIC16(L)F1829.

When using the PIC16F1829 in assembly, the reader will be constantly referring back to [Figure 2-9](#) to make sure that the right bank is selected before writing to an SFR.

For PIC18 devices, the banking situation was streamlined so that the user does not have to switch banks when using the access SFRs. The data memory is configured with an Access Bank, which allows users to access a mapped block of memory without specifying a Bank Select Register (BSR). The Access Bank consists of the first 96 bytes of memory in Bank 0 and the last 160 bytes of memory in Bank Block 15. This lower half is known as the “Access RAM” and is composed of GPRs. The upper half is where the device’s SFRs are mapped (Bank 15). When going through the assembly lessons, the reader will notice the absence of bank switching. [Figure 2-10](#) and [Figure 2-11](#) show this improved mapping scheme.

# PICKit™ 3 Starter Kit User's Guide

**FIGURE 2-10: PIC18F14K22 DATA MEMORY MAP**

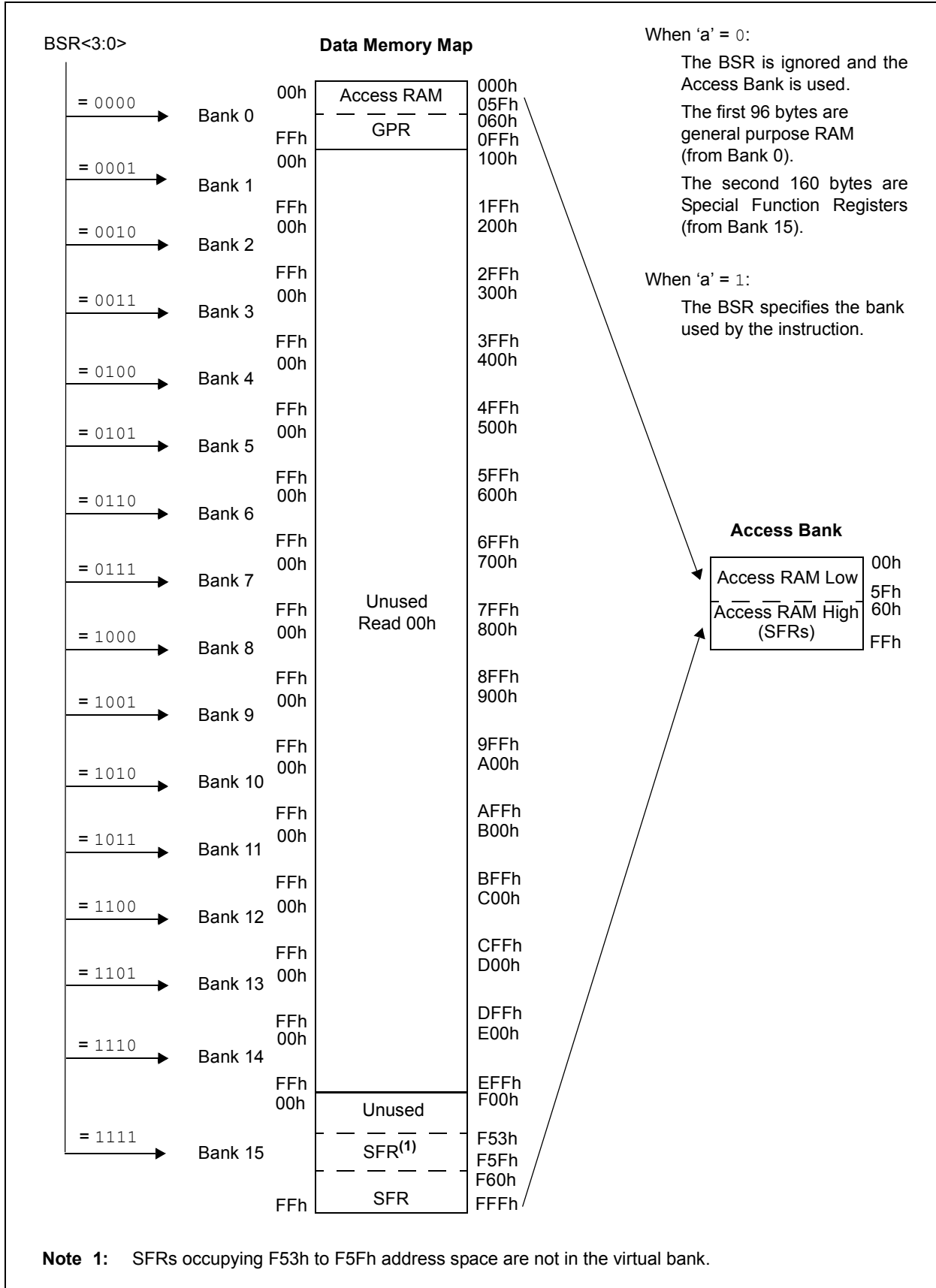

**FIGURE 2-11: PIC18F14K22 SPECIAL FUNCTION REGISTER MAP – ALL OF THESE ARE IN BANK 15 WHICH IS INCLUDED IN THE “ACCESS RAM”**

Address	Name	Address	Name	Address	Name	Address	Name	Address	Name
FFFh	TOSU	FD7h	TMR0H	FAFh	SPBRG	F87h	__ <sup>(2)</sup>	F5Fh	__ <sup>(2)</sup>
FFEh	TOSH	FD6h	TMR0L	FAEh	RCREG	F86h	__ <sup>(2)</sup>	F5Eh	__ <sup>(2)</sup>
FFDh	TOSL	FD5h	T0CON	FADh	TXREG	F85h	__ <sup>(2)</sup>	F5Dh	__ <sup>(2)</sup>
FFCh	STKPTR	FD4h	__ <sup>(2)</sup>	FACH	TXSTA	F84h	__ <sup>(2)</sup>	F5Ch	__ <sup>(2)</sup>
FFBh	PCLATU	FD3h	OSCCON	FABh	RCSTA	F83h	__ <sup>(2)</sup>	F5Bh	__ <sup>(2)</sup>
FFAh	PCLATH	FD2h	OSCCON2	FAAh	__ <sup>(2)</sup>	F82h	PORTC	F5Ah	__ <sup>(2)</sup>
FF9h	PCL	FD1h	WDTCON	FA9h	EEADR	F81h	PORTB	F59h	__ <sup>(2)</sup>
FF8h	TBLPTRU	FD0h	RCON	FA8h	EEDATA	F80h	PORTA	F58h	__ <sup>(2)</sup>
FF7h	TBLPTRH	FCFh	TMR1H	FA7h	EECON2 <sup>(1)</sup>	F7Fh	ANSELH	F57h	__ <sup>(2)</sup>
FF6h	TBLPTRL	FCEh	TMR1L	FA6h	EECON1	F7Eh	ANSEL	F56h	__ <sup>(2)</sup>
FF5h	TABLAT	FCDh	T1CON	FA5h	__ <sup>(2)</sup>	F7Dh	__ <sup>(2)</sup>	F55h	__ <sup>(2)</sup>
FF4h	PRODH	FCCh	TMR2	FA4h	__ <sup>(2)</sup>	F7Ch	__ <sup>(2)</sup>	F54h	__ <sup>(2)</sup>
FF3h	PRODL	FCBh	PR2	FA3h	__ <sup>(2)</sup>	F7Bh	__ <sup>(2)</sup>	F53h	__ <sup>(2)</sup>
FF2h	INTCON	FCAh	T2CON	FA2h	IPR2	F7Ah	IOCB		
FF1h	INTCON2	FC9h	SSPBUF	FA1h	PIR2	F79h	IOCA		
FF0h	INTCON3	FC8h	SSPADD	FA0h	PIE2	F78h	WPUB		
FEFh	INDF0 <sup>(1)</sup>	FC7h	SSPSTAT	F9Fh	IPR1	F77h	WPUA		
FEEh	POSTINC0 <sup>(1)</sup>	FC6h	SSPCON1	F9Eh	PIR1	F76h	SLRCON		
FEDh	POSTDEC0 <sup>(1)</sup>	FC5h	SSPCON2	F9Dh	PIE1	F75h	__ <sup>(2)</sup>		
FEC	PREINC0 <sup>(1)</sup>	FC4h	ADRESH	F9Ch	__ <sup>(2)</sup>	F74h	__ <sup>(2)</sup>		
FEBh	PLUSW0 <sup>(1)</sup>	FC3h	ADRESL	F9Bh	OSCTUNE	F73h	__ <sup>(2)</sup>		
FEAh	FSR0H	FC2h	ADCON0	F9Ah	__ <sup>(2)</sup>	F72h	__ <sup>(2)</sup>		
FE9h	FSR0L	FC1h	ADCON1	F99h	__ <sup>(2)</sup>	F71h	__ <sup>(2)</sup>		
FE8h	WREG	FC0h	ADCON2	F98h	__ <sup>(2)</sup>	F70h	__ <sup>(2)</sup>		
FE7h	INDF1 <sup>(1)</sup>	FBFh	CCPR1H	F97h	__ <sup>(2)</sup>	F6Fh	SSPMASK		
FE6h	POSTINC1 <sup>(1)</sup>	FBEh	CCPR1L	F96h	__ <sup>(2)</sup>	F6Eh	__ <sup>(2)</sup>		
FE5h	POSTDEC1 <sup>(1)</sup>	FBDh	CCP1CON	F95h	__ <sup>(2)</sup>	F6Dh	CM1CON0		
FE4h	PREINC1 <sup>(1)</sup>	FBCh	VREFCON2	F94h	TRISC	F6Ch	CM2CON1		
FE3h	PLUSW1 <sup>(1)</sup>	FBBh	VREFCON1	F93h	TRISB	F6Bh	CM2CON0		
FE2h	FSR1H	FBAh	VREFCON0	F92h	TRISA	F6Ah	__ <sup>(2)</sup>		
FE1h	FSR1L	FB9h	PSTRCON	F91h	__ <sup>(2)</sup>	F69h	SRCON1		
FE0h	BSR	FB8h	BAUDCON	F90h	__ <sup>(2)</sup>	F68h	SRCON0		
FDFh	INDF2 <sup>(1)</sup>	FB7h	PWM1CON	F8Fh	__ <sup>(2)</sup>	F67h	__ <sup>(2)</sup>		
FDEh	POSTINC2 <sup>(1)</sup>	FB6h	ECCP1AS	F8Eh	__ <sup>(2)</sup>	F66h	__ <sup>(2)</sup>		
FDDh	POSTDEC2 <sup>(1)</sup>	FB5h	__ <sup>(2)</sup>	F8Dh	__ <sup>(2)</sup>	F65h	__ <sup>(2)</sup>		
FDCh	PREINC2 <sup>(1)</sup>	FB4h	__ <sup>(2)</sup>	F8Ch	__ <sup>(2)</sup>	F64h	__ <sup>(2)</sup>		
FDBh	PLUSW2 <sup>(1)</sup>	FB3h	TMR3H	F8Bh	LATC	F63h	__ <sup>(2)</sup>		
FDAh	FSR2H	FB2h	TMR3L	F8Ah	LATB	F62h	__ <sup>(2)</sup>		
FD9h	FSR2L	FB1h	T3CON	F89h	LATA	F61h	__ <sup>(2)</sup>		
FD8h	STATUS	FB0h	SPBRGH	F88h	__ <sup>(2)</sup>	F60h	__ <sup>(2)</sup>		

**Legend:** = Unimplemented data memory locations, read as '0'.

**Note 1:** This is not a physical register.

**2:** Unimplemented registers are read as '0'.

All of the SFRs in Figure 2-9 are in Bank 15 and do not require banking since this bank is covered by the Access Bank. Switching banks in the enhanced mid-range core requires two instructions, so this could potentially save a great number of instructions in the overall program.

## 2.15 DATA EEPROM MEMORY

The data EEPROM is a nonvolatile memory array, separate from both the data RAM, and program memory, which is used for long-term storage of program data. The EEPROM is not directly mapped in either the register file or program memory space, but is indirectly addressed through special SFRs. The EEPROM is readable and writable during normal operation.

The PIC16F1829 and PIC18F14K22 have 256 bytes of EEPROM on board.

The EEPROM is rated for high erase/write cycle endurance. A byte write automatically erases the location and writes the new data. Please see **Section 3.14 “Lesson 13: EEPROM”** for more information.

## 2.16 PROGRAMMING BASICS

This section will briefly discuss essential assembler and ‘C’ basics. There are better suited tutorials on ‘C’ programming on the web if the user wishes to learn more.

This guide uses the XC8 compiler v.1.00 for both the PIC16F1829 and PIC18F14K22. Later versions of the compiler will also work. Looking at the XC8 user's guide would be a very good start. One of the great benefits of using ‘C’ is that it is very portable and will build in most compilers with no problem.

The assembly is not compiled, but rather assembled by a utility called MPASM. This guide uses MPASM assembler v5.43, which is a universal assembler for all PIC1X devices.

A key advantage of using a high-level language (such as C) is that the programmer does not need to understand the architecture of the microprocessor being used. Knowledge of the architecture is left to the compiler which will take the ‘C’ and compile it into assembly. When using assembly, the programmer must use the PIC device's instruction set and understand the memory map. A positive benefit of assembly is not only the knowledge gained, but also the code size will be considerably smaller.

### 2.16.1 MPASM™ Assembler Operation

All of the lessons written in are absolute code. This means that everything that the assembler needs is contained in the source files. This process is shown below.

**FIGURE 2-12: MPASM ASSEMBLER OPERATION**

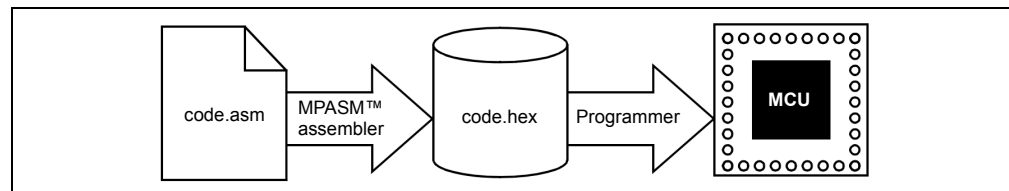

When a source file is assembled in this manner, all variables and routines used in the source file must be defined within that source file, or in files that have been explicitly included by that source file. If assembly proceeds without errors, a hex file will be generated that contains the executable machine code for the targeted PIC device. This file can then be used by the debugger to test code execution, and by a device programmer to program the microcontroller.

### 2.16.2 XC8 Operation

The compiler does all of the translation involved, which is needed to take the high-level code down to a level in which the PIC device understands. [Figure 2-13](#) explains how this is done.

**FIGURE 2-13: XC8 OPERATION**

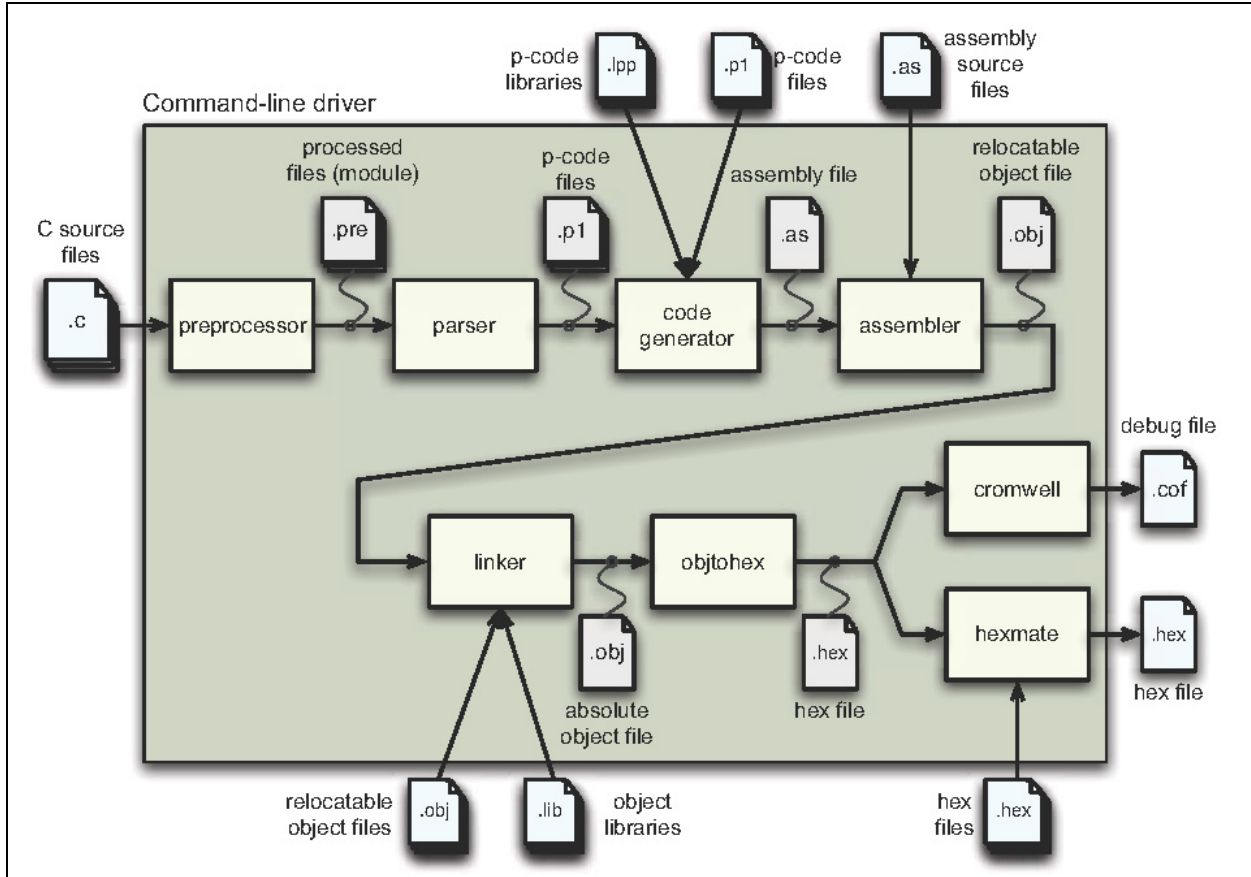

Notice how the output is the same for both the compiler/assembler – a hex file. The assembly that the compiler generates can be seen in the disassembly window inside of the MPLAB® IDE.

**FIGURE 2-14: DISASSEMBLY FIGURE**

```

36:
37:          OSCCON = 0b00100010; //500KHz clock speed
3F8A 0E22    MOVLW 0x22
3F8C 6ED3    MOVWF 0xfd3, ACCESS
38:          TRISC = 0; //all LED pins are outputs
3F8E 0E00    MOVLW 0
3F90 6E94    MOVWF 0xf94, ACCESS
39:          LATC = 0;
3F92 0E00    MOVLW 0
3F94 6E8B    MOVWF 0xf8b, ACCESS
    
```

Figure 2-14 shown above shows part of the disassembly of lesson 5. The 'C', which is indented, is easier to understand and write. The assembly underneath it contains twice as much code, and includes the PIC MCU specific instructions to achieve the desired result of the 'C' above it.

## 2.16.3 Numbers in the Assembler

Unless otherwise specified, the assembler assumes any numeric constants in the program are hexadecimal (base 16). Binary (base 2), octal (base 8), decimal (base 10), and ASCII coding are also supported.

**TABLE 2-1: NUMBERS IN THE ASSEMBLER**

Radix	Format	Example
Hexadecimal	# or 0x# or H'#'	12 or 0x12 or H'12'
Decimal	.# or D'#' Octal or O'#'	.12 or D'12' Octal or O'12'
Binary	B'#'	B'00010010'
ASCII	A'#' or '#'	A'c' or 'c'

## 2.16.4 Numbers in the XC8 Compiler

Unless otherwise specified, the compiler assumes any numeric constants in the program are decimal (base 10).

**TABLE 2-2: NUMBERS IN THE COMPILER**

Radix	Format	Example
Hexadecimal	0x#	0x12
Decimal	#	12
Binary	0b#	0b00010010
ASCII	'#'	'c'

## 2.17 MPASM ASSEMBLER DIRECTIVES

Directives are assembler commands that appear in the source code, but are not usually translated directly into opcodes. They are used to control the assembler: its input, output, and data allocation.

Many of the assembler directives have alternate names and formats. These may exist to provide backward compatibility with previous assemblers from Microchip, and to be compatible with individual programming practices.

All of the directives for the MPASM assembler can be found inside the IDE under [Help->Help Contents](#)

### 2.17.1 Banksel

```
banksel label
```

This directive is an instruction to the assembler and linker to generate bank selecting code to set the bank to the bank containing the designated *label*. The programmer should always use this directive instead of setting the BSR directly, to avoid the possibility of human error.

### 2.17.2 cblock

#### EXAMPLE 2-5:

```
cblock [address]
Variable
endc
```

This is used to define a block of variables starting at address *address*.

## 2.17.3 `Org (addr)`

`Org` tells the assembler where to start generating code at `addr`. Normally, the lessons would start code at address `0x0000`.

## 2.17.4 `End`

`End` tells the assembler to stop assembling. There must be one at the end of the program. It does not necessarily have to be at the end of the file, but nothing after the end statement will be assembled.

## 2.17.5 `Errorlevel`

This is used to suppress warnings that the assembler may give. It is vital that the programmer understand the message before hiding them from the output window.

### EXAMPLE 2-6:

```
"MESSAGE 302 – Operand Not in Bank 0, check to ensure bank bits are correct"
```

## 2.17.6 `#include`

### EXAMPLE 2-7:

```
include "include_file"  
#include <include_file>
```

The specified file is read in as source code. The effect is the same as if the entire text of the included file were inserted into the file at the location of the include statement.

The angled brackets (`< >`) indicate that the file can be found in the library folder of the assembler. Double quotes (`" "`) indicate that the include file is in the current working directory. The exact locations can be changed in the IDE.

# PICKit™ 3 Starter Kit User's Guide

---

NOTES:



## Chapter 3. Lessons

All of the following 13 lessons will include important code snippets, as well as new registers and instructions for each PIC MCU. Each lesson introduces either a new peripheral or feature. There may be slight differences between the PIC16 and PIC18 in each lesson, but the differences are pointed out and explained. The enhanced PIC16 is explained first, followed by the PIC18. There are sometimes minimal differences between the two and, when none exist, a statement of “none” will appear in the PIC18 section(s).

Subsequent lessons inherit these differences, however they are explained only in their first appearance. This is why it will be vital that the lessons are done in sequence. These differences are mostly in the assembly, not in the ‘C’ programs due to the nature of the language. It is strongly recommended that the assembly be done alongside the ‘C’ version for each lesson.

The lessons follow this folder structure:

1. <architecture>
  - a. <language>
    - i. <lesson>
      1. <lesson>.X (MPLABX project)
      2. Mplab8 (MPLAB 8.x project)
      3. <lesson> . <language> (source file)

For example:

2. PIC16
  - a. Assy
    - i. 01 Hello World
      1. Hello\_world.X (MPLABX project)
      2. Mplab8 (MPLAB 8.x project)
      3. Hello\_world.asm
  - b. C
    - i. 01 Hello World
      1. Hello\_world.X (MPLABX project)
      2. Mplab8 (MPLAB 8.x project)
      3. Hello\_world.c

A single source file is shared between both projects, meaning that any changes to the file while using MPLAB® X will be reflected in the MPLAB® 8 project as well. It is encouraged that the new IDE, MPLAB X, be used. Only the source file should be edited and nothing else in the project folders.

Please see the getting started videos that are linked to on the Start Page inside of the MPLAB X IDE. Refer to the MPLAB® IDE Quick Start Guide (DS51281) (<http://ww1.microchip.com/downloads/en/DeviceDoc/51281d.pdf>) as a getting started guide for MPLAB 8.XX.

### 3.1 LESSONS

#	Lesson	New Modules			New Concepts	New Registers			New Instructions		
		ALU	Latch	Port		TRISC	PORTC	LATC	BSF	BCF	CLRF
1	Hello World	ALU	Latch	Port	Basics of PIC MCU programming	TRISC	PORTC	LATC	BSF	BCF	CLRF
2	Blink	1. GPR 2. SRF 3. ACCESS RAM 4. Oscillator			1. Delay 2. I/O 3. Banking	OSCCON			MOVLW	DECFSZ	GOTO
									MOVWF	BRA	BTG
3	Rotate				Bit Check	STATUS			BTFSC	LSRF	RRCF
4	Analog-to-Digital	ADC			Bit shift	ANSEL	ADCON0/1/2		SWAPF		
5	Variable Speed Rotate	Hardware Stack			Functions				CALL	RETURN	XORWF
									TSTFSZ	RCALL	
6	Debounce				Preprocessor Macros						
7	Reversible Variable Speed Rotate				Modular Code				RLNCF		
8	Pulse-Width Modulation	ECCP			1. PWM resolution 2. PWM frequency 3. Modulation	CCPxCON	PRx	TxCON	ANDLW		
						CCPTMRS		CCPRxL			
9	Timer0	Timer0			Timers	OPTION_REG		T0CON			
10	Interrupts and Pull-ups	1. Interrupt Vector (High/Low) 2. Weak pull-up			1. Usefulness of interrupts	IOCAN		IOCA		RETFIE	
						IOCAF		RCON			
						WPUA					
11	Indirect Addressing	Virtual registers			1. Pointers	INDFx		FSRx		INCF	
12	Look-up Table	Program Memory Read			1. Memory conservation 2. Self Read 3. State Machine	EEADRx	EEDATx	EECON1	MOVIW	RETLW	BRW
						PCL		PCLATH		TBLRD*	
						TBLPTR		TABLAT			
13	EEPROM	Nonvolatile Memory			Low Power	EECON2			SLEEP		

## 3.2 LESSON 1: HELLO WORLD (TURN ON AN LED)

### 3.2.1 Introduction

The first lesson shows how to turn on an LED.

### 3.2.2 Hardware Effects

DS1 will light up and stay lit indefinitely.

### 3.2.3 Summary

The LEDs are connected to input-output pins (I/O) RC0 through RC3. First, the I/O pin must be configured for an output. In this case, when one of these pins is driven high (RC0 = 1), the LED will turn on. These two logic levels are derived from the power pins of the PIC MCU. Since the PIC device's power pin (VDD) is connected to 5V and the source (VSS) to ground (0V), a '1' is equivalent to 5V, and a '0' is 0V.

### 3.2.4 New Registers

#### 3.2.4.1 BOTH

**TABLE 3-1: NEW REGISTERS FOR BOTH DEVICES**

Register	Purpose
LATC	Data Latch
PORTC	Holds the status of all pins on PORTC
TRISC	Determines if pin is input (1) or output (0)

#### 3.2.4.2 LATC

The data latch (LATx registers) is useful for read-modify-write operations on the value that the I/O pins are driving. A write operation to the LATx register has the same effect as a write to the corresponding PORTx register. A read of the LATC register reads of the values held in the I/O port latches.

#### 3.2.4.3 PORTC

A read of the PORTC register reads the actual I/O pin value. Writes should be performed on the LAT register instead of on the port directly.

#### 3.2.4.4 TRISC

This register specifies the data direction of each pin connected to PORTC.

**TABLE 3-2: TRIS DIRECTION**

TRIS value	Direction
1	input
0	output

An easy way to remember this is that the number '1' looks like the letter 'I' for input, and the number '0' looks like the letter 'O' for output.

The reader should always write to the latch and read from the port.

## 3.2.5 New Instructions

All of the instructions for the enhanced mid-range or PIC18 can be studied in detail in the “**Instruction Set Summary**” chapter in each corresponding PIC® microcontroller data sheet. This document will briefly explain the importance of each.

### 3.2.5.1 BOTH

**TABLE 3-3: NEW INSTRUCTIONS FOR BOTH DEVICES**

Instruction	English	Purpose
bsf	Bit Set	Make the bit a '1' (5V)
bcf	Bit Clear	Make the bit a '0' (0V)
clrf	Clear File Register	Force the register to all 0's

#### 3.2.5.2 bsf

Set a bit in register.

#### EXAMPLE 3-1:

```
bsf LATC, 0
```

**Before Instruction:**

```
RC0 = 0
```

**After Instruction:**

```
RC0 = 1
```

#### 3.2.5.3 bcf

Clear a bit in register.

#### EXAMPLE 3-2:

```
bcf LATC, 0
```

**Before Instruction:**

```
RC0 = 1
```

**After Instruction:**

```
RC0 = 0
```

#### 3.2.5.4 clrf

This clears an entire register. It is useful during initialization to turn off all attached peripherals such as LEDs.

#### EXAMPLE 3-3:

```
clrf LATC
```

**Before Instruction:**

```
LATC = b'11011000'
```

**After Instruction:**

```
LATC = b'00000000'
```

## 3.2.6 Assembly

### 3.2.6.1 ENHANCED MID-RANGE

#### EXAMPLE 3-4:

```
#include <p16F1829.inc>
__CONFIG _CONFIG1, (_FOSC_INTOSC & _WDTE_OFF & _PWRTE_OFF & _MCLRE_OFF &
_CP_OFF & _CPD_OFF & _BOREN_ON & _CLKOUTEN_OFF & _IESO_OFF & _FCMEN_OFF);
__CONFIG _CONFIG2, (_WRT_OFF & _PLLEN_OFF & _STVREN_OFF & _LVP_OFF);

errorlevel -302 ;suppress the 'not in bank0' warning

ORG 0
Start:
banksel TRISC ; select bank1
bcf TRISC,0 ; make IO Pin C0 an output
banksel LATCH ; select bank2
clrf LATCH ; init the LATCH by turning off everything
bsf LATCH,0 ; turn on LED C0 (DS1)
goto $ ; sit here forever!

end
;
```

```
;
```

This starts a comment. Any text on this line following the semicolon is ignored by the assembler. Be sure to place lots of these in your code for readability.

```
#include <p16xxxx.inc>
```

The `p16F1829.inc` defines all of the PIC device-specific SFRs as well as other memory addresses. This should always be the first line of your program after any header comments and before the `__CONFIG` directive.

```
__CONFIG
```

This sets the processor's Configuration bits. Before this directive is used, the processor must be declared! Refer to the PIC16F1829 data sheet for the description of each Configuration Word used here. The most important of these is the 'MCLRE\_OFF', which turns off master clear on RA3.

```
Errorlevel -302
```

This suppresses the printing of the warning: "MESSAGE 302 – Operand not in Bank 0, check to ensure bank bits are correct".

```
Org xx
```

This sets the program origin for subsequent code at the address `xx`. If no `org` is specified, code generation will begin at address 0.

```
Start:
```

This is a label. Labels are assigned the same memory address as the opcode immediately following the label. Labels can, and should be, used in your code to specify the destination for `call`, `goto` and `branch` instructions.

```
Banksel TRISC
```

# PICkit™ 3 Starter Kit User's Guide

This is a very important directive that is used the most in the enhanced mid-range core. This is an instruction to the assembler and linker to generate bank selecting code to set the bank to the one containing the TRISC register. In our case, that is Bank 1. This takes one instruction cycle.

```
bcf    TRISC, 0
```

This allows pin RC0 to be an output. A '1' in the register configures the pin for an input and a '0' for output.

```
clrf  LATC
```

It is good practice to initialize all output registers to '0'. It is not guaranteed that all registers will be cleared on Reset.

```
bsf    LATC, 0
```

This turns on DS1 on PortC0.

```
goto  $
```

This merely tells the assembler to go to the current instruction, which it will do indefinitely.

## 3.2.6.2 PIC18

### EXAMPLE 3-5:

```
#include <p18F14K22.inc>

;Config settings
CONFIG IESO = OFF, PLEN = OFF, FOSC = IRC, FCMEN = OFF, PCLKEN = OFF
CONFIG BOREN = SBORDIS, BORV = 19, PWRTEN = OFF, WDTEN = OFF
CONFIG MCLRE = OFF, HFOFST = OFF, DEBUG = OFF, STVREN = ON
CONFIG XINST = OFF, BBSIZ = OFF, LVP = OFF
CONFIG CP0 = OFF, CP1 = OFF
CONFIG CPD = OFF, CPB = OFF
CONFIG WRT0 = OFF, WRT1 = OFF
CONFIG WRTB = OFF, WRTC = OFF, WRTD = OFF
CONFIG EBTR0 = OFF, EBTR1 = OFF
CONFIG EBTRB = OFF

errorlevel -302          ;suppress the 'not in bank0' warning

ORG 0
Start:
    bcf    TRISC,0        ;make IO Pin C0 an output
    clrf  LATC           ;init the LATCH by turning off everything
    bsf   LATC,0         ;turn on LED C0 (DS1)
    goto  $              ;sit here forever!

end
```

The Configuration Words and the CONFIG directive are different here. The PIC18 has more feature-rich configurations. Please see the PIC18F14K22 data sheet for more information on what each Configuration Word does.

The most important different distinction here is the lack of having to change banks. All of the SFRs are in the Access Bank and do not require a banksel statement.

## 3.2.7 C Language

The reader should notice that the PIC16 and PIC18 source code for the 'C' language is very similar.

### 3.2.7.1 ENHANCED MID-RANGE

#### EXAMPLE 3-6:

```
#include <htc.h>                //PIC hardware mapping

//config bits that are part-specific for the PIC16F1829
__CONFIG(FOSC_INTOSC & WDTE_OFF & PWRTE_OFF & MCLRE_OFF & CP_OFF & CPD_OFF &
BOREN_ON & CLKOUTEN_OFF & IESO_OFF & FCMEN_OFF);
__CONFIG(WRT_OFF & PLLEN_OFF & STVREN_OFF & LVP_OFF);

//Every program needs a `main` function
void main(void) {
    TRISbits.TRISC0 = 0;        //using pin as output
    LATC = 0;                   //init to zero
    LATCbits.LATC0 = 1;        //turn on the LED by writing to the latch
    while(1) continue;        //sit here forever doing nothing
}
```

```
//
```

This starts a comment. Any of the following text on this line is ignored by the compiler. Be sure to place lots of these in your code for readability.

```
#include <htc.h>
```

The *htc.h* file will automatically load the correct header file for the selected processor, which is selected when first creating a project.

```
__CONFIG
```

This programs the Configuration Words. See the data sheet for more specific information on these.

```
void main(void)
```

Every 'C' program needs, and starts in, the `main` function.

```
LATCbits.LATC0 = 1
```

The `LATCbits` is a structure defined in the included file (*htc.h*). The program only needs to select DS1, which is located at pin RC0. This could also have been done: `LATC |= 0b00000001`. This performs an "or-equals" operation which will preserve all of the pins except C0. If the "or" operation was omitted: `LATC = 0b00000001`, then all of the bits except C0 will be cleared.

```
while (1) continue;
```

This `while` statement will always evaluate to be true, and the `continue` statement merely stays in the current loop. It will sit here forever. The `continue` statement is not required for correct operation.

Notice how few lines were needed to replicate the same behavior as the assembly version.

## 3.2.7.2 PIC18

There is nothing different from the PIC16 version, except for the Configuration Words. For more information, see the PIC18F14K22 data sheet.

## 3.3 LESSON 2: BLINK

### 3.3.1 Introduction

This lesson blinks the same LED used in the previous lesson (DS1). This may seem trivial, but it requires a deep understanding on how the PIC MCU executes each instruction if using the assembly version.

### 3.3.2 Hardware Effects

DS1 blinks at a rate of approximately 1.5 seconds.

### 3.3.3 Summary

One way to create a delay is to spend time decrementing a value. In assembly, the timing can be accurately programmed since the user will have direct control on how the code is executed. In 'C', the compiler takes the 'C' and compiles it into assembly before creating the file to program to the actual PIC MCU (HEX file). Because of this, it is hard to predict exactly how many instructions it takes for a line of 'C' to execute.

MPLAB X and MPLAB 8.xx both have options on viewing the disassembly in a 'C' project. After a successful build of the program, the instructions that the compiler created can be viewed.

### 3.3.4 New Registers

#### 3.3.4.1 BOTH

**TABLE 3-4: NEW REGISTERS FOR BOTH DEVICES**

Register	Purpose
OSCCON	Sets the Processor speed

#### 3.3.4.1.1 OSCCON

This register should always be written to in every program. It is important to set the processor speed so that the delay loops are accurate. If it is not written to, like in the first lesson, then the frequency will default to 500 kHz if using the PIC16F1829, and 1 MHz if using the PIC18F14K22. This varies between devices.

### 3.3.5 New Instructions

#### 3.3.5.1 BOTH DEVICES

**TABLE 3-5: NEW INSTRUCTIONS FOR BOTH DEVICES**

Instruction	English	Purpose
<code>movlw</code>	Move literal into WREG	Move bytes around
<code>movwf</code>	Move literal from WREG into register	Move bytes around
<code>decfsz</code>	Decrement the register – skip next line if zero	Useful for delay loops
<code>bra label</code>	Relative to the label	Makes code modular
<code>goto label</code>	Unconditional	Make code modular

#### 3.3.5.1.1 `movlw`

An 8-bit literal, or rather constant, is loaded into the Working Register (W)

```
movlw 0x5A
```

**After instruction:** W = 0x5A

# PICkit™ 3 Starter Kit User's Guide

In assembly, this is the most common instruction. Data is typically moved into WREG, where operations can be performed or moved into another register.

## 3.3.5.1.2 `movwf`

Similar to `movlw`, data is moved from WREG to another register.

### EXAMPLE 3-7:

```
movwf OPTION_REG
```

#### Before Instruction:

```
OPTION_REG = 0xFF
```

```
W = 0x4F
```

#### After Instruction:

```
OPTION_REG = 0x4F
```

```
W = 0x4F
```

## 3.3.5.1.3 `decfsz`

Use this to decrement a register by one. If the register is '0' after decrementing, then the next instruction is skipped. This is useful for delay loops.

## 3.3.5.1.4 `bra/goto`

These two instructions are used to jump to a new section of code. A (BRA) is a relative jump from where the program counter is currently at. For the enhanced core, the counter can access  $-256 \leq n \leq 255$  locations in program memory. The PIC18 BRA can access  $-1024 \leq n \leq 1023$  locations in program memory. Notice how the value is signed. A branch is nice since it can jump across page boundaries on the enhanced mid-range core.

The `goto` is an unconditional jump and can access every location in the current page on the enhanced mid-range. The PIC18 can access all program memory with a `goto`. The downside of this is that it requires two words of programming memory. This means that each `goto` instruction in PIC18 requires twice as much space than the BRA.

In PIC18, when the destination is within 1024 program locations, a relative should be used instead of a `GOTO`. In enhanced mid-range, the relative branch offers an advantage only when crossing back and forth between pages.

## 3.3.5.2 PIC18

TABLE 3-6: NEW INSTRUCTIONS FOR PIC18

Instruction	English	Purpose
<code>btg</code>	Toggle Bit	Blink LED

### 3.3.5.2.1 `BTG`

This will invert the value of a bit in the target register.

## 3.3.6 Assembly

### 3.3.6.1 ENHANCED MID-RANGE

### EXAMPLE 3-8:

```
movlw    b'00111000'    ;set cpu clock speed
movwf    OSCCON
```

This configures the PIC MCU to run at 500 kHz. The working register (WREG) is used to move bytes into the register. Upon default, if this register was not written to, the PIC16F1829 would also run at 500 kHz. Other PIC devices are different, however, so this should always be written to in the first few lines of code. The PIC MCU will now execute with each instruction taking eight microseconds, as seen in [Equation 3-1](#):

### EQUATION 3-1: DELAY SPEED

$$Instruction\ time = \frac{1}{F_{OSC}} = \frac{1}{\frac{500kHz}{4}} = 8\ \mu S$$

In order to make the LED blink, the program needs some way of turning on the LED, waiting for a set amount of time, and then turning it off for the same period. This can be achieved by using the on-board RAM.

### EXAMPLE 3-9:

```
cblock 0x70      ;shared memory location that is accessible from all banks
Delay1          ; Define two file registers for the delay loop in shared memory
Delay2
endc
```

Remember that `CBLOCK` allocates user memory. The number after `CBLOCK` is the address of where to put the memory. `0x70` is the address of shared memory across all banks in the enhanced mid-range core. Only 16 bytes can be saved here. Now the program does not need to change banks when using any of these variables. The rest of the lessons will be using variables stored here on the PIC16 and in access RAM for the PIC18. Two variables will be stored here to write the following delay loop.

### EXAMPLE 3-10:

```
bsf    LATC, 0      ; turn LED on
OndelayLoop:
decfsz Delay1,f     ; Waste time.
bra    OndelayLoop ; The Inner loop takes 3 instructions per loop * 256 loops = 768
instructions
decfsz Delay2,f     ; The outer loop takes an additional 3 instructions per lap * 256 loops
bra    OndelayLoop ; (768+3) * 256 = 197376 instructions / 125K instructions per second =
1.579 ;sec.
bcf    PORTC,0      ; Turn off LED C0 - NOTE: do not need to switch banks with 'banksel'
since ;bank0 is still selected
OffDelayLoop:
decfsz Delay1,f     ; same delay as above
bra    OffDelayLoop
decfsz Delay2,f
bra    OffDelayLoop
bra    MainLoop    ; Do it again...
```

The `bra` Loop backs up and repeats. This loop takes three instruction times; one for the decrement and two for the `bra`, and the counter will force it to go around 256 times, which takes a total of 768 instruction times to execute. Even that is still too fast for the eye to see. It can be slowed down even more by adding a second loop around this one. The inner loop still takes 768 cycles plus three for the outer loop, but now it is executed another  $(768+3) * 256 = 197376$  instructions/125K instructions per second = 1.579s.

`goto` and `bra` instructions take two instructions due to the pipelined design of the processor. The processor fetches the next instruction while executing the current instruction. When a program occurs, the already fetched instruction located after the `goto` or `bra` is not executed. Instead, a `NOP` is executed while the instruction located at the destination is fetched.

# PICkit™ 3 Starter Kit User's Guide

---

The variables, `Delay1` and `Delay2` will rollover from 0 to 255. This is why it is unnecessary to assign a value to the `Delay1` and `Delay2` variables before decrementing.

## 3.3.6.2 PIC18

While the Enhanced Core has its 16 bytes of general purpose RAM that is shared between all banks, the PIC18 has its equivalent at locations `0x00`→`0x5F`. It gives the user access to 96 bytes, which the user can access without specifying the bank.

### EXAMPLE 3-11:

```
cblock 0x00 ; Access RAM
Delay1      ; Define two file registers for the delay loop in shared memory
Delay2
endc
```

## 3.3.7 C Language

### 3.3.7.1 BOTH

Delay loops in 'C' that are based solely on a variable counter result in an unpredictable delay time. The compiler essentially breaks down your code into assembly before being programmed onto the PIC MCU. Depending on how efficient the compiler is and how well the program is written will determine the length of time the loop takes. A library function for a delay loop is the preferred method.

For completion, this lesson includes both ways. The commented out section at the end of the code in this lesson uses the accurate delay function that is bundled in with the XC8 compiler. Subsequent lessons will use the built-in delay macro.

### EXAMPLE 3-12:

```
#define _XTAL_FREQ 500000 //Used by the HI-TECH delay_ms(x) macro
```

In order to take advantage of this highly accurate routine, the PIC MCU processor speed must be defined.

### EXAMPLE 3-13:

```
delay = 7500;
while (1) {
    while(delay-- != 0)continue; //each instruction is 8us (1/(500KHz/4))
    LATCbits.LATC0 ^= 1; //toggle the LED
    delay = 7500; //assign a value since it is at 0 from the
                  delay loop
```

A variable, `delay`, is created and then decremented before toggling an LED. The ^ XORs the pin with '1' to create the toggling affect. If the optimization of the compiler is heightened or lowered, the delay will increase or decrease since the compiler produces different code for each optimization level.

## 3.4 LESSON 3: ROTATE

### 3.4.1 Introduction

Rotate the lit LED between the four available LEDs.

### 3.4.2 Hardware Effects

LEDs rotate from right to left.

### 3.4.3 Summary

This lesson will introduce shifting instructions as well as bit-oriented skip operations to move the LED display.

### 3.4.4 New Registers

#### 3.4.4.0.1 BOTH

**TABLE 3-7: NEW REGISTERS FOR BOTH DEVICES**

Register	Purpose
STATUS	Used to check ALU status

#### 3.4.4.0.2 STATUS

The STATUS register is automatically updated in hardware after every arithmetic operation. This is used to check for the following conditions:

1. Zero
2. Digit Carry
3. Carry
4. Overflow
5. Negative

The **Instruction Set Summary** section in each PIC microcontroller data sheet will indicate what instructions affect which bit(s).

### 3.4.5 New Instructions

#### 3.4.5.1 BOTH

**TABLE 3-8: NEW INSTRUCTIONS FOR BOTH DEVICES**

Instruction	English	Purpose
<code>btfsc</code>	Skip next line if bit is clear	If/Else statements

#### 3.4.5.1.1 BTFSC

This tests a specific bit in a specific register. If it is clear (value of '0'), then the next instruction is skipped. This is useful for performing `IF-ELSE` statements.

# PICkit™ 3 Starter Kit User's Guide

## 3.4.5.2 ENHANCED MID-RANGE

**TABLE 3-9: NEW INSTRUCTIONS FOR ENHANCED MID-RANGE**

Instruction	English	Purpose
lsrcf	Logical shift right	Shift bits to the right

## 3.4.5.3 PIC18

**TABLE 3-10: NEW INSTRUCTIONS FOR PIC18**

Instruction	English	Purpose
rrcf	Rotate right through carry	Shift bits to the right

### 3.4.5.3.1 lsrcf/rrcf

The difference between a logical shift and a shift through carry is that a logical shift right will shift in a '0' from the left. The latter will shift whatever was in the carry bit to the left most bit. They both shift the LSb into the carry bit. For example:

**FIGURE 3-1: LOGIC SHIFT TO THE RIGHT**

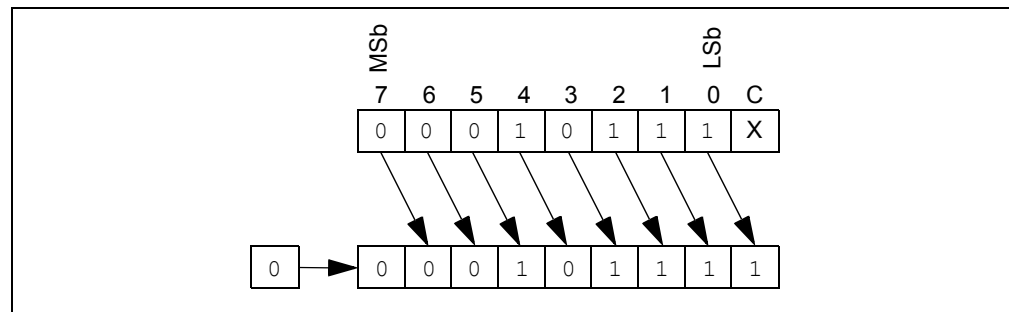

**FIGURE 3-2: ROTATE RIGHT THROUGH CARRY**

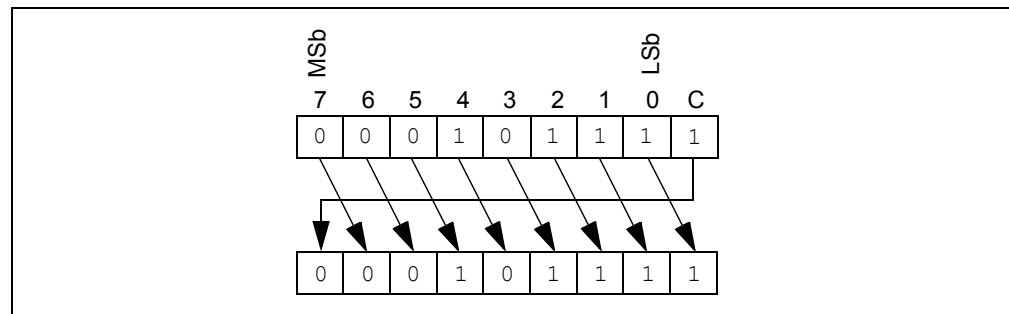

If a bit is shifted into a carry, it is crucial that the designer clear it before a next rotate is performed since the bit will then be shifted into the register, unless of course, that is what is intended.

## 3.4.6 Assembly

### 3.4.6.1 ENHANCED MID-RANGE

**EXAMPLE 3-14:**

```

Rotate:
  lsrcf  LATC,F      ;shift the LEDs and turn on the next LED to the right
  btfsc  STATUS,C    ;did the bit rotate into the carry (i.e. was DS1 just lit?)
  bsf    LATC, 3     ;yes, it did and now start the sequence over again by turning on DS4
  goto   MainLoop   ;repeat this program forever
    
```

DS1 is connected to RC0 and DS2 to RC1 and so forth. A shift to the right would actually be turning on the LEDs from right to left. This can be better explained in the following figures.

**TABLE 3-11: PIN TO LED MAPPING**

LATC								
Bit #	MSb (7)	6	5	4	3	2	1	LSb (0)
LED	—	—	—	—	DS4	DS3	DS2	DS1

Start of program begins with lighting up DS4;

**TABLE 3-12: LED ROTATE**

LATC								
Bit #	MSb (7)	6	5	4	3	2	1	LSb (0)
LED	—	—	—	—	DS4	DS3	DS2	DS1
value	0	0	0	0	1	0	0	0

After the delay, a logic shift to the right is performed:

**TABLE 3-13: LED ROTATE**

LATC								
Bit #	MSb (7)	6	5	4	3	2	1	LSb (0)
LED	—	—	—	—	DS4	DS3	DS2	DS1
value	0	0	0	0	0	1	0	0

Now DS3 is lit. The carry bit now contains whatever was previously in `LATCbits.LATC0`. In this case, it was '0'. The program then checks if the carry bit was set. This will only be true if DS1 was previously lit, and then an `lshrf` was performed. Now, the carry bit would be set and the following line would be executed.

**EXAMPLE 3-15:**

```
bsf LATC, 3 ;yes, it did and now start the sequence over again by turning on DS4
```

Now the program will restart the sequence by relighting DS4. It is important to note that the MSb, bit 7, will ALWAYS be cleared. This is due to the nature of the `lshrf` instruction.

**3.4.6.2 PIC18**

The PIC18 does not have the same logical shift instruction as the enhanced mid-range.

**EXAMPLE 3-16:**

```
Rotate:
  rrcf LATC,f ;rotate the LEDs (through carry) and turn on the next LED to the right
  btfs STATUS,C ;did the bit rotate into the carry (i.e. was DS1 just lit?)
  goto MainLoop ;nope, repeat this program forever
  bsf LATC, 3 ;yes, it did and now start the sequence over again by turning on DS4
  bcf STATUS, C ;clear the carry
  goto MainLoop ;repeat this program forever
```

The PIC18 can rotate through carry or not. If not, the LSb would simply be loaded into the MSb. The program needs to use the carry bit to test if it rotated the LED out of the displayable range, much like in the PIC16. The only difference is now the carry bit MUST be cleared when it rotates out of the display. If it is not cleared, the program will light up DS3 as intended, but soon all LEDs will be lit since LATCbits.LATC7 will be set, and then subsequent rotations will move it down onto the visible range of <RC3:RC0>.

## 3.4.7 C Language

### 3.4.7.1 BOTH

The 'C' version is much simpler and easier to understand. The program delays for 500 ms, shifts the LATC register to the right, and then checks if the carry bit in LATC is set. If so, the program will set RC3 in anticipation of the next rotate.

#### EXAMPLE 3-17:

```
__delay_ms(500); //delay 500ms
LATC >> = 1;    //shift to the right by 1
if(STATUSbits.C) //when the last LED is lit, restart the pattern
    LATCbits.LATC3 = 1;
```

It is important to note that the above shift is a logical shift since it is an unsigned register. The STATUS register is still updated after the shift. The shift in [Example 3-17](#) incorporates one of the many short-hand notations of 'C', as described in [Example 3-18](#).

#### EXAMPLE 3-18:

```
LATC >> = 1;
This is equivalent as:
LATC = LATC >> 1;
Or rather:
lshf LATC,F ;shift the LEDs and turn on the next LED to the right
```

## 3.5 LESSON 4: ANALOG-TO-DIGITAL CONVERSION

### 3.5.1 Introduction

This lesson shows how to configure the ADC, run a conversion, read the analog voltage controlled by the potentiometer (RP1) on the board, and display the high order four bits on the display.

### 3.5.2 Hardware Effects

The top four MSBs of the ADC are mirrored onto the LEDs. Rotate the potentiometer to change the display.

### 3.5.3 Summary

Both PIC devices have an on-board Analog-to-Digital Converter (ADC) with 10 bits of resolution on any of 11 channels. The converter can be referenced to the device's VDD or an external voltage reference. The lesson references it to VDD. The result from the ADC is represented by a ratio of the voltage to the reference.

#### EQUATION 3-2:

$ADC = (V/V_{REF}) * 1023$
<p>Converting the answer from the ADC back to voltage requires solving for V.</p>
$V = (ADC/1023) * V_{REF}$

Figure 1-1 (Section 1.4 “Included Items”) shows the wiper on the potentiometer is connected to pin RA0.

Here’s the checklist for this lesson:

1. Configure the ADC pin as an analog input.
2. Select clock scaling.
3. Select channel, result justification, and VREF source.

### 3.5.4 New Registers

#### 3.5.4.1 BOTH

**TABLE 3-14: NEW REGISTERS FOR BOTH DEVICES**

Register	Purpose
ANSELX	Determines if the pin is digital or analog.
ADCON0	Selects ADC channel – Enables module – Contains the “I’m done with conversion” bit

#### 3.5.4.1.1 ANSEL:

The ANSEL register determines whether the pin is a digital (1 or 0) or analog (varying voltage) I/O. I/O pins configured as analog input have their digital input detectors disabled and, therefore always read ‘0’ and allow analog functions on the pin to operate correctly. The state of the ANSELX bits have no effect on digital output functions. When setting a pin to an analog input, the corresponding TRIS bit must be set to Input mode in order to allow external control of the voltage on the pin.

This lesson sets RA0 as an analog input, since the POT will vary the voltage.

# PICkit™ 3 Starter Kit User's Guide

The PIC18F14K22 has a slightly different ANSEL register, but the functionality is the same. The top row of each register screen shot in every PIC microcontroller data sheet and in this document indicates more information on the functionality of each bit, such as its default state. The bit `ANSA0`, is read/writable, and will default to an analog input both on Power-on Reset (POR) and Brown-out Reset (BOR). A BOR will happen if the supply voltage sags below the threshold determined by the Configuration Words.

## 3.5.4.1.2 ADCON0

ADCON0 controls the ADC operation. Bit 0 turns on the ADC module. Bit 1 starts a conversion and bits <6:2> select which channel the ADC will read.

For purposes of this lesson, the ADC must be turned on with RA4 selected as the input channel. Choose the internal voltage reference and 8TOSC conversion clock. The ADC needs about 5  $\mu$ s, after changing channels, to allow the ADC sampling capacitor to settle. Finally, the conversion can be started by setting the GO bit in ADCON0. The GO bit also serves as the DONE flag. That is, the ADC will clear the GO bit in hardware when the conversion is complete. The result is then available in ADRESH:ADRESL.

The Most Significant four bits of the result are copied and displayed on the LEDs driven by PORTC.

**TABLE 3-15: ADC RESULT THAT IS LEFT JUSTIFIED – BITS IN BLUE ARE MIRRORED TO LATC. BIT 6 CONTROLS DS1, BIT 7 CONTROLS DS2, AND SO FORTH.**

Reg	ADRESH								ADRESL	
Bit #	10	8	7	6	5	4	3	2	1	(LSb) 0

## 3.5.4.2 PIC16

**TABLE 3-16: NEW REGISTERS FOR ENHANCED MID-RANGE**

Register	Purpose
ADCON1	Result format – Speed – Reference voltage

## 3.5.4.3 PIC18

**TABLE 3-17: NEW REGISTERS FOR PIC18**

Register	Purpose
ADCON1	Reference voltage
ADCON2	Result format – Speed

### 3.5.4.3.1 ADCON1:

ADCON1 for the PIC16 and ADCON2 for the PIC18 select the ratio between processor clock speed and conversion speed. This is important because the ADC needs at least 1.6  $\mu$ s conversion time per bit. Accuracy degrades if the clock speed is too high or too slow. As the processor clock speed increases, an increasingly large divider is necessary to maintain the conversion speed.

ADFM bit <7> selects whether the ten result bits are right or left justified. The program will left justify the result so that the two LSbs are contained in ADRESL and the top eight in ADRESH. The program, however, will only use the top four MSbs in ADRESH.

The ADNREG/ADPREG bits select the ADC reference, which may be either VDD or a separate reference voltage on VREF.

## 3.5.5 New Instructions

### 3.5.5.1 BOTH

**TABLE 3-18: NEW INSTRUCTIONS FOR BOTH DEVICES**

Instruction	English	Purpose
SWAPF	Swapf WREG with register	Swap nibbles

#### 3.5.5.1.1 swapf

This allows nibbles to be switched. A nibble consists of four bits and a byte contains two nibbles. For example:

**EXAMPLE 3-19:**

```
movlw    b'01100110'
```

**TABLE 3-19: BEFORE SWAPF**

Registers	Value
WREG	B'01100110'

ADC is performed. ADRESH is full with ADC result of b'10100011'.

**TABLE 3-20: BEFORE SWAPF**

Registers	Value
ADRESH	B'10100011'

**EXAMPLE 3-20:**

```
swapf    ADRESH, w ; now perform the swapf and save in WREG, leaving
                    ADRESH intact
```

**TABLE 3-21: AFTER SWAPF**

Registers	After swapf
WREG	B'0011-1010'
ADRESH	B'1010-0011'

**FIGURE 3-3: SWAPF DIAGRAM**

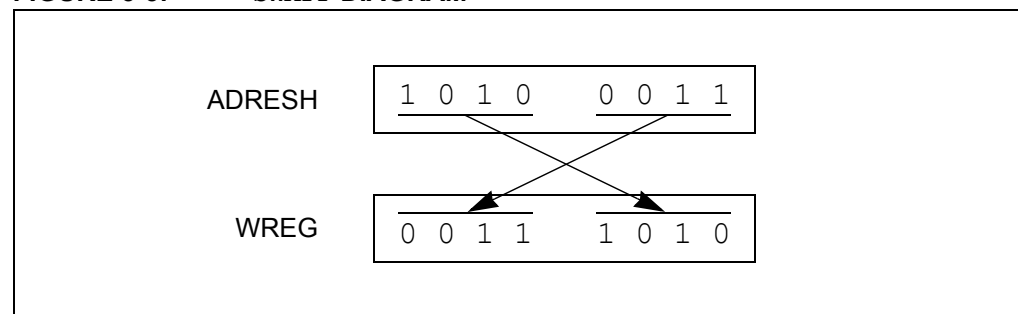

# PICkit™ 3 Starter Kit User's Guide

## 3.5.6 Assembly

### 3.5.6.1 ENHANCED MID-RANGE

```
;Start the ADC
nop                ;required ADC delay of 8uS => (1/(Fosc/4)) = (1/(500KHz/4)) = 8uS
banksel    ADCON0
bsf        ADCON0, GO ;start the ADC
btfsc     ADCON0, GO ;this bit will be cleared when the conversion is complete
goto      $-1       ;keep checking the above line until GO bit is clear

;Grab Results and write to the LEDs
swapf     ADRESH, w ;Get the top 4 MSBs (remember that the ADC result is LEFT justified!)
banksel   LATC
movwf     LATC      ;move into the LEDs
bra       MainLoop
```

It is important to note that the ADC result is left justified. This allows the `swapf` instruction to move the top four MSBs onto LATC.

#### EXAMPLE 3-21:

```
goto      $-1       ;keep checking the above line until GO bit is clear
```

The dollar sign represents the current value of the address counter. The `$-1` tells the assembler to make the destination of the `goto` one less than the current address, in other words, the previous instruction.

#### 3.5.6.2 PIC18:

#### EXAMPLE 3-22:

```
goto      $-2       ;keep checking the above line until GO bit is clear
```

Notice how it is `$-2` instead of `'1'`. This is a very important difference. PIC18 instruction words are two bytes long, and program memory in the PIC18 is byte addressable. The previous instruction is two bytes back in address space. PIC18 instructions always have an even numbered address.

## 3.5.7 C Language

### 3.5.7.0.1 Both Devices:

#### EXAMPLE 3-23:

```
__delay_us(5);      //wait for ADC charging cap to settle
GO = 1;
while (GO) continue; //wait for conversion to be finished
LATC = (ADRESH >> 4); //grab the top 4 MSBs
```

Here, the ADRESH register is shifted to the right by four spaces. For an unsigned variable, shifts are logical. For example:

TABLE 3-22: ADRESH BEFORE SHIFT

ADRESH – before shift								
Bit #	MSb (7)	6	5	4	3	2	1	LSb (0)
value	0	1	0	1	1	1	0	1

```
ADRESH >> 4; //grab the top 4 MSBs
```

**TABLE 3-23: TEMPORARY WORKSPACE REGISTER AFTER SHIFT**

ADRESH – after shift								
Bit #	MSb (7)	6	5	4	3	2	1	LSb (0)
value	0	0	0	0	0	1	0	1

Now LATC can be assigned to the temporary workspace register, since all of the LEDs are on pins <RC3:RC0>. The rest of the bits in PORTC can be ignored.

Most of the LEDs will not turn on when the POT is turned clockwise, because the top four MSBs are being grabbed, meaning that there needs to be a great swing in voltage change to affect the topmost MSBs. As an added exercise, try using the lower nibble (bits 0 through 3) and assign them to LATC. The LEDs will change more frequently.

# PICKit™ 3 Starter Kit User's Guide

## 3.6 LESSON 5: VARIABLE SPEED ROTATE

### 3.6.1 Introduction

This lesson combines all of the previous lessons to produce a variable speed rotating LED display that is proportional to the ADC value. The ADC value and LED rotate speed are inversely proportional to each other.

### 3.6.2 Hardware Effects

Rotate the POT counterclockwise to see the LEDs shift faster.

### 3.6.3 Summary

A crucial step in this lesson is to check if the ADC value is 0. If it does not perform the zero check, and the ADC result is zero, the LEDs will rotate at an incorrect speed. This is an effect of the delay value underflowing from 0 to 255.

FIGURE 3-4: PROGRAM FLOW

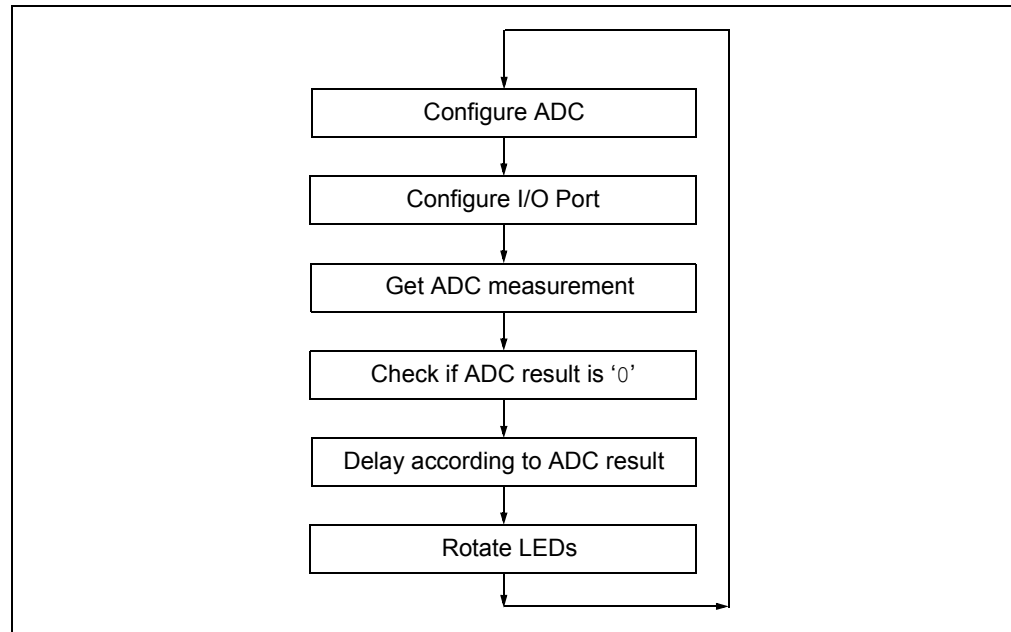

### 3.6.4 New Registers

None

### 3.6.5 New Instructions

3.6.5.1 BOTH

TABLE 3-24: NEW INSTRUCTIONS FOR BOTH DEVICES

Instruction	English	Purpose
<code>call label</code>	Call a subroutine	Modular code
<code>return</code>	Return to previous call statement	Modular code
<code>xorwf</code>	XOR register with WREG	Toggle a register

#### 3.6.5.1.1 `call`

The `call` is equivalent to adding functions in 'C'. They are convenient since they allow the designer to create subroutines which can then be called from a main function. This improves the memory use efficiency and readability of your program.

Calls use one stack level. Remember that the PIC18 has a stack size of 31 levels, whereas the enhanced core has 16 levels. Anytime a `call` is performed, the return address will be pushed to the stack, then the program counter will go to the location in program memory where the `label` is located.

It is important to note that stack depth should not be exceeded. For instance, performing 17 embedded call statements on the PIC16F1829 without returning at least once will cause a Stack Overflow.

On the PIC18, a `call` instruction takes up two words of program space, however, a PIC18 `call` can be anywhere in the program space. On the enhanced mid-range, a `call` must first set the page select bits if the `call` is to be outside the currently selected page.

### 3.6.5.1.2 `return`

A `return` restores the program counter to the last address that was saved into the stack, and the Stack Pointer moves to the previous `call` in the list counter. The PC will now be at the instruction immediately following the `call`. A Stack Underflow will be caused if the program executes a `return` statement with no prior `call`.

In any case, the programmer can use the STVREN Configuration bit to cause a Reset if a Stack Underflow/Overflow occurs. Both the `call` and `return` instructions take two cycles.

### 3.6.5.1.3 `xorwf`

`XORWF` is used in this lesson to check if the ADC result is zero. Here is the truth table of the XOR:

**TABLE 3-25: XOR TRUTH TABLE**

Input		Output
A	B	
0	0	0
0	1	1
1	0	1
1	1	0

### EXAMPLE 3-24:

```
movlw    d'0'           ;load wreg with '0'
xorwf    Delay2, w      ;XOR wreg with the ADC result and save in wreg
btfss   STATUS, Z       ;if the ADC result is NOT '0', then simply return to MainLoop
```

This performs an exclusive-OR of the Delay2 register with '0' to check if Delay2 has a value of '0'. If so, the Z bit in the STATUS register will be set, since the answer is '0'.

### 3.6.5.2 PIC18

**TABLE 3-26: NEW INSTRUCTIONS FOR PIC18**

Instruction	English	Purpose
<code>tstfsz</code>	Test if a register is empty	Quick check if zero (IF statement)
<code>rcall</code>	Relative call	Modular code

#### 3.6.5.2.1 `TSTFSZ`

This is a quick test if a register is '0' or not. Use this instruction on the PIC18 instead of the `XORWF` used on the PIC16, since this saves a few instructions. For example:

# PICKit™ 3 Starter Kit User's Guide

## EXAMPLE 3-25:

```
tstfsz    Delay2    ;if the ADC result is NOT '0', then simply return to MainLoop
return    ;return to MainLoop
```

If Delay2 is '0', then the `return` instruction will not be executed, and instead skipped.

### 3.6.5.2.2 rcall

A relative call should be used if the location to jump to is within 1K of the current location of the Program Counter. The reason is that `rcall` consumes only one word of program spaces, whereas a regular `call` takes two words.

## 3.6.6 Assembly

### 3.6.6.1 BOTH

## EXAMPLE 3-26:

```
MainLoop:
  call    A2d          ;get the ADC result
                    ;top 8 MSBs are now in the working register (Wreg)
  movwf   Delay2      ;move ADC result into the outer delay loop
  call    CheckIfZero ;if ADC result is zero, load in a value of '1' or else
                    ;the delay loop will decrement starting at 255
  call    DelayLoop   ;delay the next LED from turning ON
  call    Rotate      ;rotate the LEDs

  bra    MainLoop     ;do this forever
```

The main loop is now more readable than before. There are separate modules, or functions for the ADC, delay loop, and rotate. Be sure to `return` after a `call`, and not a `goto`.

The `CheckIfZero` is necessary so that the delay loop does not rollover to 255 from 0. If this `call` is omitted and the ADC result is '0', then the LEDs will rotate very slowly.

## 3.6.7 C Language

This implementation is much easier to understand.

## EXAMPLE 3-27:

```
__delay_ms(50); //delay for AT LEAST 50ms
while (delay-- != 0) __delay_ms(2); //decrement the 8 MSBs of the ADC and delay
                                   2ms for each
```

The routine will delay at least 50 ms when the ADC result is zero. For each increment of the returned ADC value, the loop will pause for 2 ms.

This lesson also introduces function calls.

```
delay = adc(); //grab the top 8 MSBs
```

This is the equivalent of implementing a `call` in assembly. The program counter will go to where this ADC function is in program space and execute code. It will then return a single value and assign it to `delay`.

A key note is that any function that is instantiated after the `main` function must have a prototype.

```
unsigned char adc(void); //prototype
```

## 3.7 LESSON 6: DEBOUNCE

### 3.7.1 Introduction

Mechanical switches play an important and extensive role in practically every computer, microprocessor and microcontroller application. Mechanical switches are inexpensive, simple and reliable. In addition, switches can be very noisy. The apparent noise is caused by the closing and opening action that seldom results in a clean electrical transition. The connection makes and breaks several, perhaps even hundreds, of times before the final switch state settles.

The problem is known as switch bounce. Some of the intermittent activity is due to the switch contacts actually bouncing off each other. Imagine slapping two billiard balls together. The hard non-resilient material does not absorb the kinetic energy of motion. Instead, the energy dissipates over time and friction in the bouncing action against the forces pushing the billiard balls together. Hard metal switch contacts react in much the same way. Also, switch contacts are not perfectly smooth. As the contacts move against each other, the imperfections and impurities on the surfaces cause the electrical connection to be interrupted. The result is switch bounce.

The consequences of uncorrected switch bounce can range from being just annoying to catastrophic. For example, imagine advancing the TV channel, but instead of getting the next channel, the selection skips one or two. This is a situation a designer should strive to avoid.

Switch bounce has been a problem even before the earliest computers. The classic solution involved filtering, such as through a resistor-capacitor circuit, or through resetting table shift registers. These methods are still effective, but they involve additional cost in material, installation and board real estate.

**FIGURE 3-5: SWITCH DEBOUNCING**

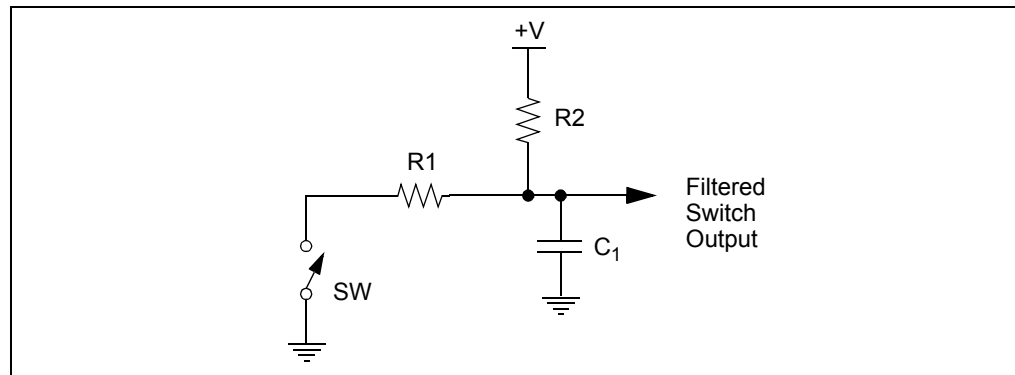

One of the simplest ways to switch debounce is to sample the switch until the signal is stable or continue to sample the signal until no more bounces are detected. How long to continue sampling requires some investigation. However, 5 ms is usually plenty long, while still reacting fast enough that the user will not notice.

The switch on the LPC Demo Board does not bounce much, but it is good practice to debounce all switches in the system.

### 3.7.2 Hardware Effects

When the switch is held down, DS1 will be lit. When the switch is not held down, all LEDs are OFF.

# PICkit™ 3 Starter Kit User's Guide

---

## 3.7.3 Summary

This lesson uses a simple software delay routine to avoid the initial noise on the switch pin. The code will delay for only 5 ms, but should overcome most of the noise. The required delay amount differs with the switch being used. Some switches are worse than others.

This lesson also introduces the `#define` preprocessing symbol in both 'C' and assembly. Hard coding pin locations is bad practice. Values that may be changed in the future should always be defined once in preprocessing. Imagine if another user wanted to use these lessons in a different PIC device and all of the pins changed! This would require going into the code and finding every instance of any pin reference.

### EXAMPLE 3-28:

```
#define SWITCH PORTA, 3 ;pin where SW1 is connected..NOTE: always READ from  
                        the PORT and WRITE to the LATCH  
#define LED LATCH, 0 ;DS1
```

Now all that is needed is to change this one line and it will be reflected everywhere it is used.

```
bsf LATCH, 0 ;turn on the LED
```

```
bsf LED ;turn on the LED
```

The preprocessor will substitute `LATCH, 0` every time the `LED` identifier is seen. This is done before the code is assembled/compiled, or rather processed, hence the name preprocessor.

## 3.7.4 New Registers

Nothing new.

## 3.7.5 New Instructions

Nothing new.

## 3.7.6 Assembly

### 3.7.6.1 ENHANCED MID-RANGE

### EXAMPLE 3-29:

```
MainLoop:  
  banksel PORTA ;get into Bank0  
  btfsc SWITCH ;defined above...notice how the PORT is being read and not the LATCH  
  bra LedOff ;switch is not pressed - turn OFF the LED  
  bra Debounce ;switch is held down, pin needs to be debounced
```

There is only one important main difference in this lesson from previous ones. Notice how the port is being read, and not the latch, when the program is checking the switch. If `LATCH` is substituted in where `PORTC` is, the switch will never be detected. Remember to read from the port and write to the latch. Read-modify-write operations on the `LATCH` register will read and write the latched output value for `PORTC`.

## 3.7.7 PIC18

Nothing new.

## 3.7.8 C Language

Nothing new.

## 3.8 LESSON 7: REVERSIBLE VARIABLE SPEED ROTATE

### 3.8.1 Introduction

This lesson combines all of the previous lessons in using the button to reverse the direction of rotation when the button is pressed. The speed of rotation is controlled using the potentiometer.

### 3.8.2 Hardware Effects

LEDs will rotate at a speed that is proportional to the ADC value. The switch will toggle the direction of the LEDs.

### 3.8.3 Summary

The program needs to keep track of rotation direction and new code needs to be added to rotate in the other direction. Lesson 5 rotates right and checks for a '1' in the carry bit to determine when to restart the sequence. In Lesson 7, the program needs to rotate both ways and check for a '1' in bit 4 of the display when rotating to the left. When the '1' shows up in bit 4 of LATC, it will be re-inserted into bit 0.

**FIGURE 3-6: PROGRAM FLOW FOR LESSON 7**

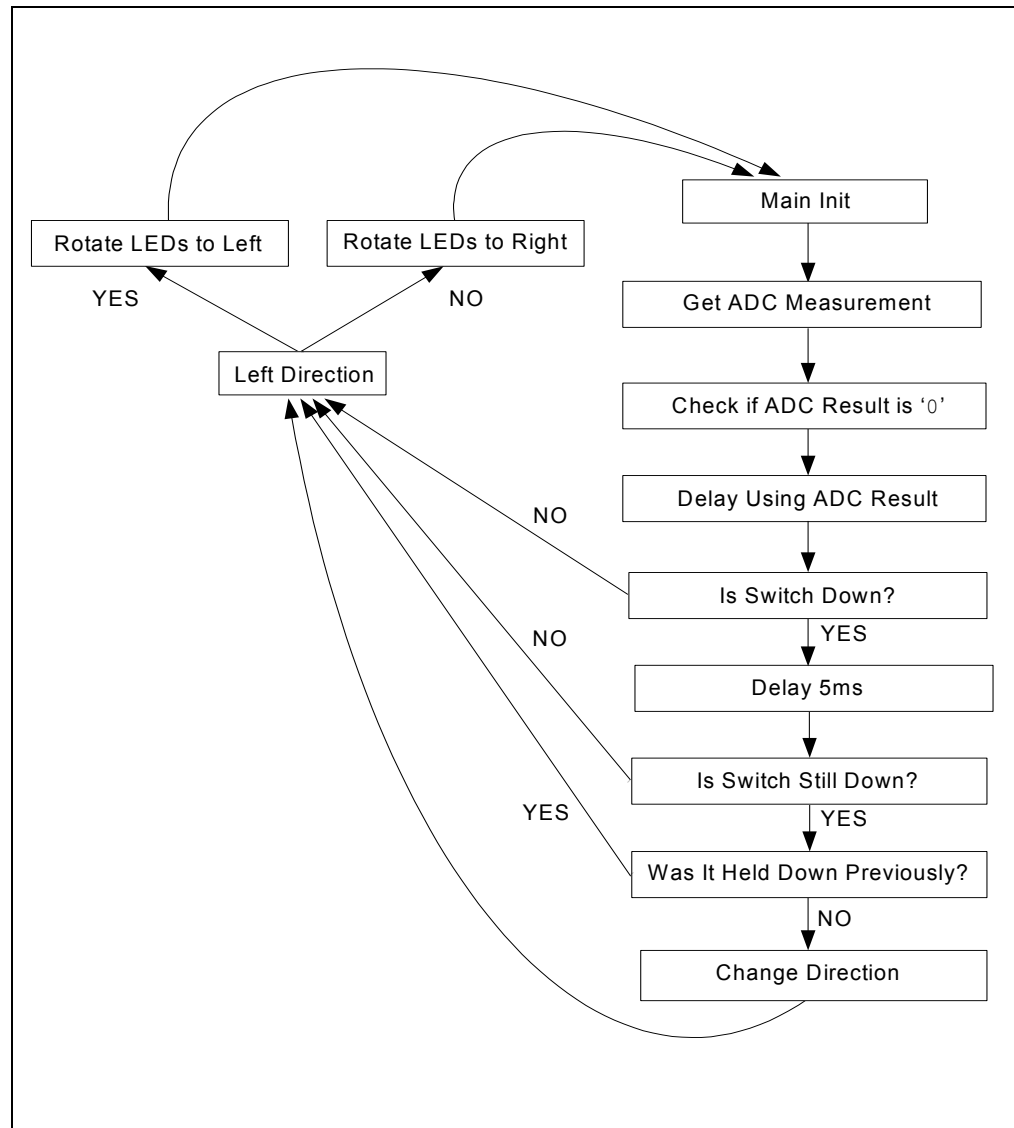

# PICkit™ 3 Starter Kit User's Guide

The debounce routine is more in-depth in this lesson because we need to keep in mind of the scenario of the switch being held down for long periods of time. If SW1 is held down, the LEDs would change direction rapidly, making the display look like it is out of control. The above flowchart will only change direction on the first indication of a solid press and then ignore the switch until it is released and pushed again. The switch must be pressed for at least the time it takes for the program to check the switch in its loop. Since the PIC MCU is running at 500 kHz, this will seem instantaneous.

## 3.8.4 New Registers

None.

## 3.8.5 New Instructions

### 3.8.5.1 PIC18

TABLE 3-27:

Instruction	English	Purpose
RLNCF	Rotate left with no carry	Shift bits to the left

#### 3.8.5.1.1 `rlncf`

This rotates bits to the left without using the carry bit. The LSb simply becomes the previous MSb. This is usually referred to as a circular shift.

FIGURE 3-7: ROTATE LEFT WITHOUT CARRY

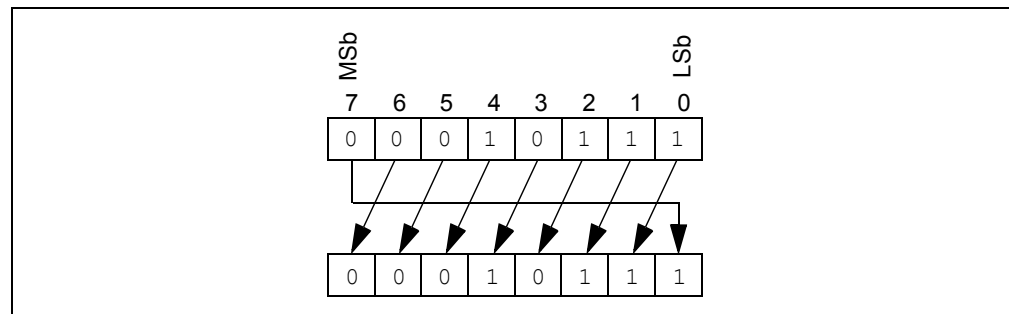

## 3.8.6 Assembly

### 3.8.6.1 ENHANCED MID-RANGE

#### EXAMPLE 3-30:

```
RotateRight:
    lslf    LATC, f        ;logical shift left
    btfsc  LATC, 4        ;did it rotate out of the LED display?
    bsf    LATC, 0        ;yes, put in bit 0
    bra    MainLoop
```

Instead of using the carry bit to check if the LEDs are out of display range, the latch is shifted to the left and LATC4 is checked. LATC4 is not connected to anything and if this is ever set, it means that DS4 was just lit and now DS1 needs to be lit to repeat the pattern. The PIC18 version is similar, but instead uses `rlncf` instead of `lslf`.

#### 3.8.6.2 PIC18

The PIC18 always has to make sure that the carry bit is cleared once it is checked, otherwise more than one LED may become lit.

## EXAMPLE 3-31:

```
RotateLeft:
    bcf     STATUS, C    ;clear the carry
    rrcf   LATC, f      ;rotate the LEDs (through carry) and turn on the next LED to the right
    btfss  STATUS, C    ;did the bit rotate into the carry (i.e. was DS1 just lit?)
    bra    MainLoop
    bsf    LATC, 3      ;yes, it did and now start the sequence over again by turning on DS4
    bcf    STATUS, C    ;clear the carry
    bra    MainLoop    ;repeat this program forever
```

## 3.8.7 C Language

### 3.8.7.1 BOTH

This version utilizes global variables. Unlike local variables, global variables have no function scope, meaning that they are visible to every function within the same source file where it is declared. It is good practice to uniquely identify global variables such as preceding each variable with an underscore.

```
unsigned char _previous_state = SWITCH_UP; //global variable
```

This byte is modified in the `check_switch` function, and the result is returned to the main loop.

## EXAMPLE 3-32:

```
void main(void) {
    unsigned char delay;
    unsigned char direction;
    .....
}
unsigned char check_switch(void) {
    ...
    ..
}
```

Notice how the bytes, `delay` and `direction`, were declared inside of `main`. These cannot be modified anywhere outside of `main`. Also, notice how `check_switch` returns an unsigned char byte to the main loop. In 'C', only one variable can be returned.

## 3.9 LESSON 8: PULSE-WIDTH MODULATION (PWM)

### 3.9.1 Introduction

This lesson does not rely on any of the previous lessons, but does use the same coding techniques and information learned thus far.

In this lesson, a PIC MCU generates a PWM signal that lights an LED with the POT thereby controlling the brightness.

### 3.9.2 Hardware Effects

Rotating the POT will adjust the brightness of a single LED.

### 3.9.3 Summary

Pulse-Width Modulation (PWM) is a scheme that provides power to a load by switching quickly between fully on and fully off states. The PWM signal resembles a square wave where the high portion of the signal is considered the on state and the low portion of the signal is considered the off state. The high portion, also known as the pulse width, can vary in time and is defined in steps. A longer, high on time will illuminate the LED brighter. The frequency or period of the PWM does not change. A larger number of steps applied, which lengthens the pulse width, also supplies more power to the load. Lowering the number of steps applied, which shortens the pulse width, supplies less power. The PWM period is defined as the duration of one complete cycle or the total amount of on and off time combined.

PWM resolution defines the maximum number of steps that can be present in a single PWM period. A higher resolution allows for more precise control of the pulse width time and, in turn, the power that is applied to the load. In this lesson, the program will be using 10 bits of resolution – the maximum allowed.

The term duty cycle describes the proportion of the on time to the off time and is expressed in percentages, where 0% is fully off and 100% is fully on. In this situation, a lower duty cycle corresponds to less power applied and a higher duty cycle corresponds to more power applied.

### 3.9.4 New Registers

#### 3.9.4.1 BOTH

**TABLE 3-28: NEW REGISTERS FOR BOTH DEVICES**

Register	Purpose
CCPXCON	Setup of the “compare-capture-PWM” module
PRX	The PWM period is specified by the PRx register of Timer2/4/6
CCPTMRS	Selects what timer module is used in association with the PWM
CCPRXL	Upper 8 bits (MSb) of PWM
TXCON	Timer control register

#### 3.9.4.1.1 All

The PIC16F1829 has two CCP modules and this lesson will use CCP2, while the PIC18F14K22 only has one CCP module, so it will use CCP1.

It is recommended that the reader refer to the Capture/Compare/PWM section in the data sheet to learn about each register above. This lesson will briefly cover how to setup a single PWM.

[Figure 3-8](#) summarizes how the PWM waveform is setup:

**FIGURE 3-8: PWM ANALYSIS**

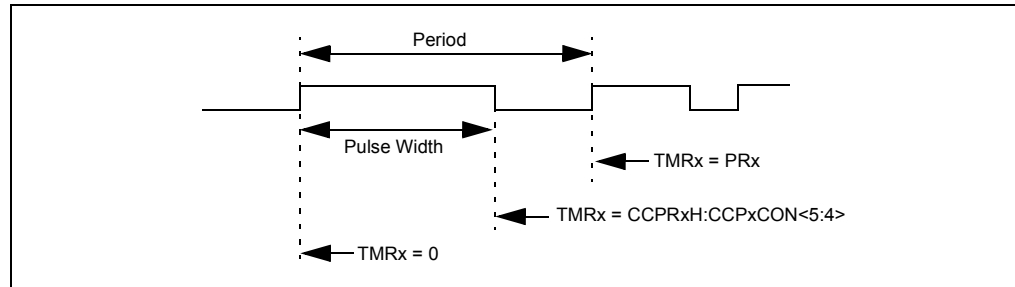

The PWM period is specified by the PRx register. Timer 2/4/6 is used to count up to the value in CCPRxH combined with two LSbs in CCPxCON. CCPRxL is used to load CCPRxH. One can think of CCPRxL as a buffer which can be read or written to, but CCPRxH is read-only. When the timer is equal to PRx, the following three events occur on the next increment cycle:

1. TMRx is cleared
2. The CCPx pin is set
3. The PWM duty cycle is latched from CCPRxL into CCPRxH

The following steps should be executed in the order shown when configuring the CCP module for standard PWM operation:

1. Select the Timer2/4/6 resource to be used for PWM generation by setting the CxTSEL<1:0> bits in the CCPTMRS register.
2. Disable the CCPx pin output driver by setting the associated TRIS bit.
3. Load the PRx register with the PWM period value.
4. Configure the CCP module for the PWM mode by loading the CCPxCON register with the appropriate values
5. Load the CCPRxL register and the DCxBx bits of the CCPxCON register, with the PWM duty cycle value.
6. Configure and start Timer2/4/6:
  - a) Clear the TMRxIF interrupt flag bit of the PIRx register.
  - b) Configure the TxCKPS bits of the TxCON register with the Timer prescale value.
  - c) Enable the Timer by setting the TMRxON bit of the TxCON register.
7. Enable PWM output pin.

This lesson uses a frequency of 486 Hz. Anything over ~60 Hz will eliminate any noticeable flicker.

**EXAMPLE 3-33:**

$$;PWM \text{ Period} = [PR2 + 1] * 4 * T_{osc} * T2CKPS = [255 = 6 + 1] * 4 * (1/500kHz) * 1$$

The designer should also consider the PWM resolution.

**EQUATION 3-3: PWM RESOLUTION**

$$Resolution = \frac{\log[4(PR_x + 1)]}{\log(2)} \text{ bits}$$

Two conditions must hold true for this lesson:

1. 10 bits of resolution
2. No flicker in LED

# PICKit™ 3 Starter Kit User's Guide

Both devices are using some features of the enhanced PWM module. The PIC16 will operate the CCP module in single output since the CCP2 P2A pin connects directly to DS4. The PIC18 will operate the CCP module in Full-Bridge mode in order to modulate P1D on DS3.

Maximum resolution is achieved when the PRx register is set to 0xFF, or rather 255, the maximum value an 8-bit number can hold.

Below is a scope capture of the PWM signal when the LED is dimly lit. As one can see, the Period is around ~2 ms, with the pulse width being only few hundred us wide.

**FIGURE 3-9: SMALL PULSE WIDTH**

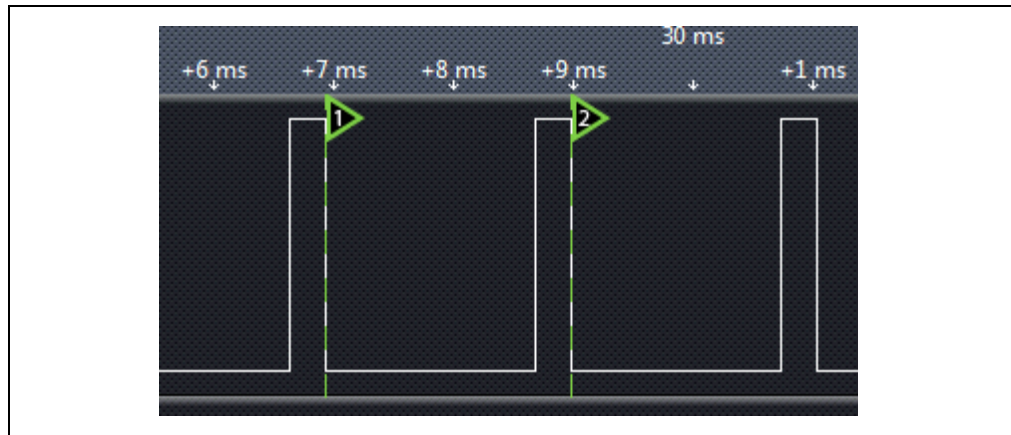
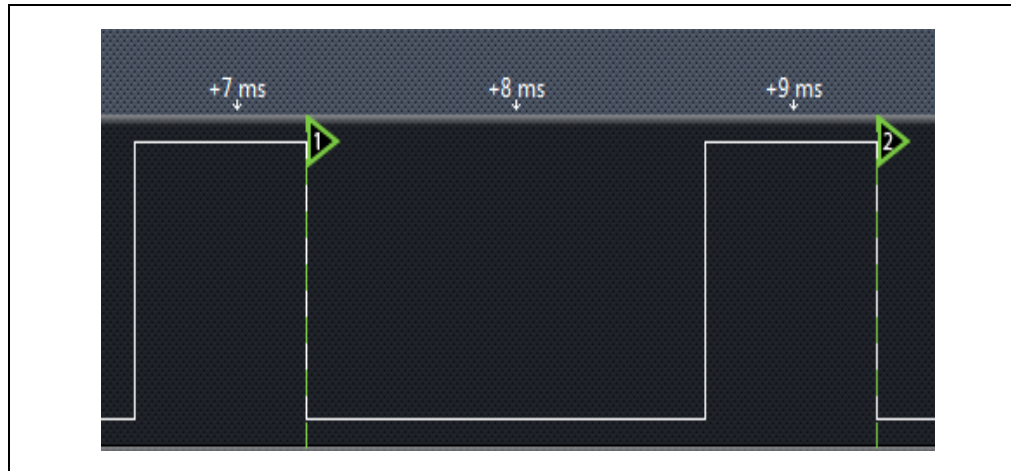

Figure 3-10 shows when the dial is turned 30% clockwise. Notice how the pulse width is greater than that shown in Figure 3-9, and that the frequency did not change.

**FIGURE 3-10: GREATER PULSE WIDTH**



**TABLE 3-29:**

Instruction	English	Purpose
andlw	And a literal with WREG	Masking values

## 3.9.5 Assembly

### 3.9.5.1 ENHANCED MID-RANGE

#### EXAMPLE 3-34:

```

call    A2d           ;begin the Analog to Digital conversion
                    ;ADRESH and ADRESL are now both full of the ADC result!
movf    ADRESH, w    ;Get the top 8 MSbs (remember that the ADC result is LEFT justified!)
banksel CCP2L
movwf   CCP2L

```

This fills the eight MSBs in the PWM register. The next few lines can be commented out and still provide the same perceived output. This is because the two LSBs do not play a significant role in terms of duty cycle resolution. This lesson uses all ten bits for completeness.

#### EXAMPLE 3-35:

```

;to fill all 10 bits of the duty cycle, the 2 LSBs will be put into the
;Duty Cycle Bits (DC2B) of the CCP2CON register which are bits 5 and 4.
;So we need to shift these LSB into place and OR them with CCP2CON
; in order to save the control settings above and fill these last bits in
banksel  ADRESL
                    ;ADRESL = b'xx000000' where 'xx' are the 2 LSBs from the
                    ;ADC result
lsrf    ADRESL, f   ;ADRESL = b'0xx00000'
lsrf    ADRESL, f   ;ADRESL = b'00xx0000'
movf    ADRESL, w   ;now move into wreg
banksel  CCP2CON
xorwf   CCP2CON, w  ;move the 2 LSBs into place without disturbing the rest of
                    ;CCP2CON settings

andlw   B'00110000'
xorwf   CCP2CON, f

bra     MainLoop    ;do this forever

```

In [Example 3-35](#), the program shifts the ADRESL register, which contains the two LSBs from the ADC result. Bits <5:0> are always cleared while bits <7:6> contain part of the ADC result. The PIC MCU will simply shift this register to the right twice so that they are in bits <5:4>. Notice how the result of the shift is saved in ADRESL and NOT in WREG. In the next three instructions: the first XOR clears bits that are the same and sets bits that are different. The result is in WREG. The next AND function clears all control bits in WREG, so they do not change in the final step. The final XOR changes the bits that changed and leaves everything else untouched. The result is saved to the CCP2CON register. A `movwf` or `iorwf` would not work, since it would not preserve the settings applied in the initialization.

#### 3.9.5.2 PIC18

The PIC18 substitutes the `rrncf` instruction with the `lsrf` instruction above, although a `rrcf` would also work.

#### 3.9.5.3 C LANGUAGE

Nothing new.

## 3.10 LESSON 9: TIMER0

### 3.10.1 Introduction

This lesson will produce the same output as **3.4 “Lesson 3: Rotate”**. The only difference is that this version uses Timer0 to provide the delay routine.

### 3.10.2 Hardware Effects

LEDs rotate from right to left, similar to Lesson 3.

### 3.10.3 Summary

Timer0 is a counter implemented in the processor. It may be used to count instruction cycles or external events, that occur at or below the instruction cycle rate.

In the PIC18, Timer0 can be used as either an 8-bit or 16-bit counter, or timer. The enhanced mid-range core implements only an 8-bit counter.

This lesson configures Timer0 to count instruction cycles and to set a flag when it rolls over. This frees up the processor to do meaningful work rather than wasting instruction cycles in a timing loop.

Using a counter provides a convenient method of measuring time or delay loops as it allows the processor to work on other tasks rather than counting instruction cycles.

### 3.10.4 New Registers

#### 3.10.4.0.1 Enhanced Mid-range

**TABLE 3-30: ENHANCED MID-RANGE NEW REGISTER**

Register	Purpose
OPTION_REG	Timer0 and pull-up/INT configuration

## 3.10.4.0.2 OPTION\_REG

This register controls Timer0 settings as well as some miscellaneous features, such as weak pull-ups, which will be used in later lessons.

## 3.10.4.1 PIC18

**TABLE 3-31: NEW REGISTERS FOR PIC18**

Register	Purpose
T0CON	Timer0 configuration

### 3.10.4.1.1 T0CON

The T0CON register and OPTION\_REG are similar with respect to the prescaler settings and Timer0 assignment bits. The enhanced mid-range Timer0 is always enabled, so there is no need to enable it. The weak pull-ups and INT detection are performed in separate registers on the PIC18.

Timer0 will generate an interrupt when the TMR0 register overflows from 0xFF to 0x00 (if in 8-bit mode for the PIC18). The TMR0IF interrupt flag bit of the INTCON register is set every time the TMR0 register overflows, regardless of whether or not the Timer0 interrupt is enabled. The TMR0IF bit can only be cleared in software. The Timer0 interrupt enable is the TMR0IE bit of the INTCON register.

## 3.10.5 Assembly

### 3.10.5.1 PIC16

**EXAMPLE 3-36:**

```

btfss    INTCON, TMR0IF ;did TMR0 roll over yet?
bra      $-1             ;wait until TMR0 overflows and sets TMR0IF
bcf      INTCON, TMR0IF ;must clear flag in software

;rotate the LEDs
.....

```

The `MainLoop` label of the program will simply wait for the timer to overflow. When it does, it will clear the flag and shift the LEDs. The flag **MUST** be cleared in software. If this lesson is compared with Lesson 3, the reader should notice a reduction in code, and that it is easier to follow. Timers greatly simplify delay loops and are great for events that need precise timing.

### 3.10.5.2 PIC18

The only differences are that the initialization is slightly different and the relative branch uses “\$-2”.

## 3.10.6 C Language

Nothing new.

## 3.11 LESSON 10: INTERRUPTS AND PULL-UPS

### 3.11.1 Introduction

This lesson introduces interrupts and how they are useful. It also introduces internal weak pull-ups that are available on most PIC devices. This lesson expands on the previous lessons, but mostly Lessons 9 and 3.

### 3.11.2 Hardware Effects

LEDs rotate at a constant speed and the switch reverses their direction.

### 3.11.3 Summary

Two new concepts are introduced: interrupts and weak pull-ups.

#### 3.11.3.1 INTERRUPTS

The interrupt feature allows certain events to preempt normal program flow. This means that the microcontroller can be configured to be aware of its surroundings. Routines can be run upon some external event. Firmware is used to determine the source of the interrupt and act accordingly. All interrupts can be configured to wake the MCU from Sleep mode.

Most of the peripherals can generate an interrupt. Some of the I/O pins may be configured to generate an interrupt when they change state. When a peripheral needs service, it sets its interrupt flag. Each interrupt flag is ANDed with its enable bit and then these are ORed together to form a master interrupt. This master interrupt is ANDed with the Global Interrupt Enable (GIE). The enable bits allow the PIC microcontroller to limit the interrupt sources to certain peripherals. See the Interrupt Logic Figure in the PIC microcontroller data sheet for a drawing of the interrupt logic. Below is a simplified diagram.

**FIGURE 3-11: SUMMARY OF INTERRUPT FLOW**

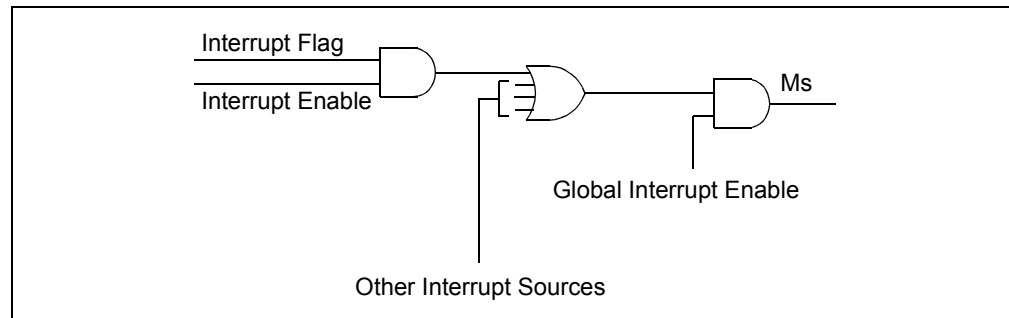

The PIC18 has a slightly different structure to accommodate interrupt priority. The enhanced mid-range core has only one interrupt vector. This means that whenever an interrupt occurs, the program counter goes to the interrupt service address, specifically address 0x0004. The PIC18 allows most interrupt sources to be assigned a high or low priority level. The high priority vector is at 0x0008 and the low at 0x0018. A high priority interrupt event will interrupt a low priority that may be in progress. This lesson will not utilize priority interrupts and will instead make use of the mid-range compatibility feature by clearing the IPEN bit. Both devices will now service from only one vector.

When an interrupt is responded to, the Global Interrupt Enable (GIE) bit is cleared to disable further interrupts. The return address is pushed onto the stack and the PC is loaded with the interrupt vector address. Both the enhanced mid-range and PIC18 devices perform automatic context saving for the WREG, STATUS, and BSR registers. The FSR and PCLATH registers are saved only in the enhanced mid-range devices. The PIC18 requires a `retfie, fast` instruction execution to restore the context.

The firmware within the Interrupt Service Routine (ISR) should determine the source of the interrupt by polling the interrupt flag bits. The serviced interrupt flag bits must be cleared before exiting the ISR to avoid repeated interrupts. Because the GIE bit is cleared, any interrupt that occurs while executing the ISR will be recorded through its interrupt flag, but will not cause the processor to redirect to the interrupt vector until the `retfie` instruction is executed, thereby enabling the GIE bit.

### 3.11.3.2 WEAK PULL-UPS

Both the enhanced mid-range and PIC18 devices in this tutorial are able to provide internal pull-up resistors on some pins. This can greatly reduce the need of external hardware. When enabled, simply disconnect the jumper, JP5, to see the effect. JP5 connects the power supply voltage (VDD) to the wiper on the potentiometer and to the pull-up resistor connected to the switch.

**FIGURE 3-12: WEAK PULL-UP DIAGRAM**

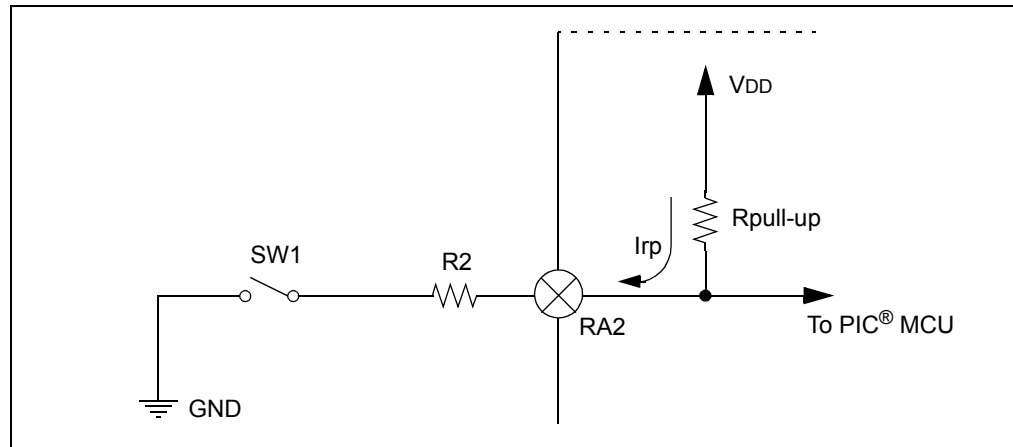

As seen in [Figure 3-12](#), by enabling the weak pull-up on a pin, the pin will always read a '1' if no other external circuitry is connected to RA2. In this demo, there is a resistor connected to the switch, which is then connected to ground. When the switch is pressed, the voltage on RA2 is no longer VDD, but rather close to 0V, or ground.

The pull-up resistor is not given a value in the electrical specifications, but rather the current,  $I_{pur}$ . For the PIC16F1829, this is typically 140  $\mu$ A. When the switch is closed, given the typical current spec, the voltage on RA2 becomes:

**EQUATION 3-4:**

$$V = I * R$$

$$V_{A3} = 140 * 10^{-6} * 2k = 28mV$$

It is called a “weak” pull-up since it does not bring the pin to VDD quickly. A stronger pull-up would have a low resistance and bring the pin quickly up to VDD. If there is a fair amount of capacitance on the pin, the pin may take a while to register as logic-high to the PIC MCU. Since it is a weak pull-up, the designer can easily override this internal setting by using an external resistor, typically in the range of 1k-10k, to change the pin's state.

## 3.11.4 New Registers

### 3.11.4.1 BOTH

**TABLE 3-32: NEW REGISTERS FOR BOTH DEVICES**

Register	Purpose
WPUA	Weak pull-up enable

This enables the individual internal pull-up circuitry for each pin on PORTA.

### 3.11.4.2 ENHANCED MID-RANGE

**TABLE 3-33: NEW REGISTERS FOR ENHANCED MID-RANGE**

Register	Purpose
IOCAN	Interrupt-on-change PORTA negative edge
IOCAF	Interrupt-on-change PORTA flags

#### 3.11.4.2.1 IOCAN/IOCAF

The PIC16F1829 can detect rising and falling edge interrupts. IOCAN contains the negative edge detection enable bits and IOCAF contains the interrupt flags. This lesson enables the switch input as an interrupt-on-change pin through IOCAN and clears all the flags in IOCAF inside the ISR.

This lesson uses the interrupt-on-change peripheral, which causes the PIC MCU to go to address 0x0004 (interrupt vector), when RA2 changes from a high-to-low state.

**FIGURE 3-13: RISING/FALLING EDGES**

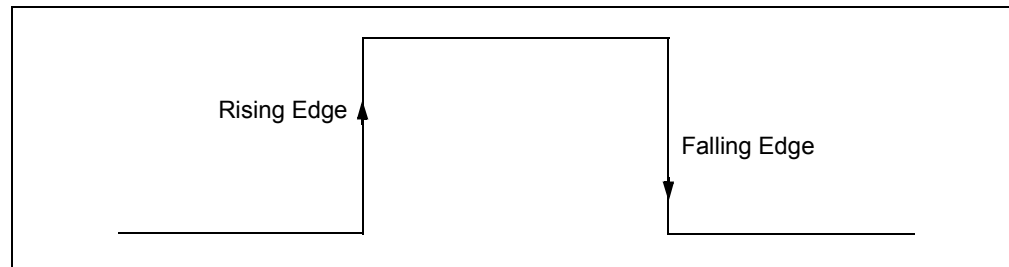

### 3.11.4.3 PIC18

**TABLE 3-34: NEW REGISTERS FOR PIC18**

Register	Purpose
IOCA	Interrupt-on-change PORTA (both edges)
RCON	Detects what caused the interrupt

#### 3.11.4.3.1 IOCA

The PIC18F14K22 does not have a negative and positive edge trigger, but rather just one that detects both. More software is needed to determine which edge occurred.

#### 3.11.4.3.2 RCON

The RCON register is used to detect what caused the PIC MCU to reset as well as enable/disable priority interrupts. This lesson shows how to use this register to disable priority interrupts.

## 3.11.5 New Instructions

### 3.11.5.1 BOTH

**TABLE 3-35: NEW INSTRUCTIONS FOR BOTH DEVICES**

Instruction	English	Purpose
<code>retfie</code>	Return from interrupt	Return to normal execution

#### 3.11.5.1.1 `retfie`

The `retfie` instruction exits the ISR by popping the previous address from the stack and setting the GIE bit. The PIC18 requires the `retfie, fast` instruction to restore the saved context, whereas the enhanced mid-range does not have this distinction.

## 3.11.6 Assembly

### 3.11.6.1 BOTH

**EXAMPLE 3-37:**

```
MainLoop:
    bra    MainLoop    ;can spend rest of time doing something critical here
```

By using interrupts, the main loop can spend time doing other things such as crunching numbers or writing to an LCD. The program no longer needs to wait for the flag to become set to continue like the previous lesson did. This example code will simply branch to `MainLoop` indefinitely, doing nothing while waiting for the interrupt.

### 3.11.6.2 ENHANCED MID-RANGE

**EXAMPLE 3-38:**

```
Org 0x0                ;Reset Vector starts at 0x0000
bra    Start           ;main code execution
ORG    0x0004          ;Interrupt Vector starts at address 0x0004
goto   ISR
```

This jumps to the ISR routine. Notice how the `goto` statement is directly after the interrupt vector address.

**EXAMPLE 3-39:**

```
;Enter here if an interrupt has occurred
;First, check what caused the interrupt by checking the ISR flags
;This lesson only has 2 flags to check
ISR:
    banksel    IOCAF        ;bank7
    btfsc     IOCAF, 3      ;check the interrupt-on-change flag
    bra       Service_SW1   ;switch was pressed
    bra       Service_TMR0  ;Timer0 overflowed
```

Inside the ISR, the cause of the interrupt is determined. Once determined, one of the services that must be completed is clearing the interrupt flag so that the ISR can be successfully left. The `retfie` instruction exits the ISR by restoring the saved context, re-enables the GIE bit and returns to the instruction following the last instruction executed when the interrupt occurred.

# PICkit™ 3 Starter Kit User's Guide

---

## EXAMPLE 3-40:

```
#ifndef PULL_UPS
    banksel   WPUA
    bsf       WPUA, 2           ;enable the weak pull-up for the switch
    banksel   OPTION_REG
    bcf       OPTION_REG, NOT_WPUEN ;enable the global weak pull-up bit
    ;this bit is active HIGH, meaning it must be cleared for it to be enabled
#endif
```

The `#ifndef` is a preprocessor directive, which will look to see if the directive, in this case `PULL_UPS`, is defined. If so, the code between the `#ifndef` and `#endif` will be assembled. These two lines activate the weak pull-up resistor on pin RA2.

### 3.11.6.3 PIC18

The PIC18 does not differentiate between rising and falling edges. Therefore, the same debounce routine and flowchart in Lesson 7 ([Figure 3-6](#)) will be used.

## EXAMPLE 3-41:

```
Org 0x0000           ;Reset Vector starts at 0x0000
bra      Start       ;main code execution

Org 0x0008           ;High Priority Interrupt Vector starts at address 0x0008
goto     ISR
```

When priority interrupts are disabled, all interrupts occur at address 0x0008.

## EXAMPLE 3-42:

```
#ifndef PULL_UPS
    bsf       WPUA, 2           ;enable the weak pull-up for the switch
    bcf       INTCON2, NOT_RABPU ;enable the global weak pull-up bit
    ;this bit is active HIGH, meaning it must be cleared for it to be enabled
#endif
```

Same as the PIC16, except that the registers and bit names are changed slightly.

### 3.11.7 C Language

The enhanced core can have only one interrupt vector defined. This is done by creating a function with the `interrupt` keyword:

```
void interrupt ISR(void)
```

This is a special name and is reserved only for the ISR. The PIC18 can have two, but this lesson uses only one as shown above.

## 3.12 LESSON 11: INDIRECT ADDRESSING

### 3.12.1 Introduction

This lesson covers a very important topic of indirect addressing. The code uses indirect addressing to implement a moving average filter. This lesson adds a moving average filter to the Analog-to-Digital code in Lesson 4. The moving average keeps a list of the last ADC values (n) and averages them together. The filter needs two parts: A circular queue and a function to calculate the average.

Twisting the potentiometer changes the value read by the Analog-to-Digital converter. The filtered value is then sent to the LED display.

The filter averages the last eight readings. Choosing a power of two for the number of samples allows division by simple rotates instead of a general purpose divide routine. Rather than summing the array every time, it is faster to keep a running sum, then subtract out the oldest value in the queue and add in the new value.

**FIGURE 3-14: MOVING AVERAGE WITH INDIRECT ADDRESSING**

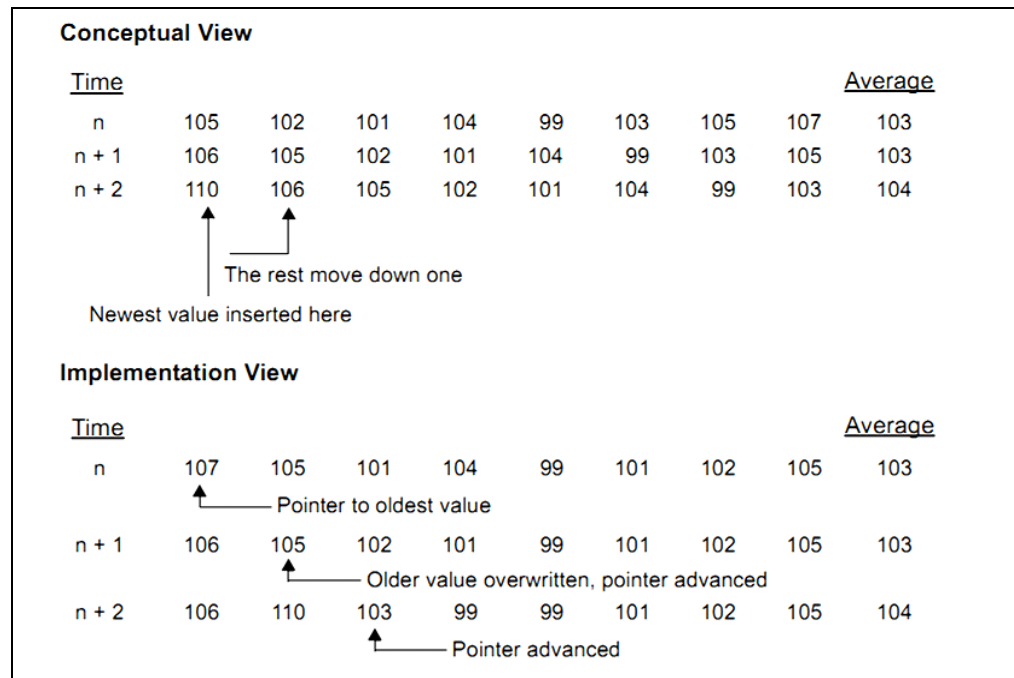

### 3.12.2 Hardware Effects

This lesson provides the same outcome as Lesson 4. The user rotates the POT to see the LEDs rotate. The top four MSBs of the ADC value are reflected onto the LEDs.

### 3.12.3 Summary

While the program memory can be addressed in only one way – through the program counter – information in the data memory space can be addressed in several ways. For most instructions, the addressing mode is fixed. Other instructions may use up to three modes, depending on which operands are used and whether or not the extended instruction set is enabled.

The addressing modes are:

1. Inherent
2. Literal
3. Direct
4. Indirect

### 3.12.3.1 INHERENT AND LITERAL

Many PIC device control instructions do not need any argument at all; they either perform an operation that globally affects the device or they operate implicitly on one register. This addressing mode is known as Inherent Addressing. Examples include `SLEEP` and `RESET`, which are used in the EEPROM lesson.

Other instructions work in a similar way but require an additional explicit argument in the opcode. This is known as Literal Addressing mode because they require some literal value as an argument. Examples include `addlw`, `movlb`, `call`, and `goto`.

### 3.12.3.2 DIRECT ADDRESSING

Direct addressing specifies all or part of the source and/or destination address of the operation within the opcode itself. The options are specified by the arguments accompanying the instruction. In the core PIC device instruction set, bit-oriented and byte-oriented instructions use some version of direct addressing by default. All of these instructions include a 7-bit (8-bit for PIC18) literal address in their Least Significant Byte. This address specifies either a register address in one of the banks of data RAM or a location in the Access Bank (if using the PIC18) as the data source for the instruction.

The destination of the operation's results is determined by the destination bit 'd'. When 'd' is '1', the results are stored back in the source register, overwriting its original contents. When 'd' is '0', the results are stored in the WREG register.

### 3.12.3.3 INDIRECT ADDRESSING

Indirect addressing allows the user to access a location in data memory without giving a fixed address in the instruction. This is done by using File Select Registers (FSRs) as pointers to the locations which are to be read or written. Since the FSRs are themselves located in RAM as Special File Registers, they can also be directly manipulated under program control. This makes FSRs very useful in implementing data structures, such as tables and arrays in data memory. The registers for indirect addressing are also implemented with Indirect File Operands (INDFs) that permit automatic manipulation of the pointer value with auto-incrementing, auto-decrementing or offsetting with another value.

The INDFn registers are not physical registers. These can be thought of as "virtual" registers: they are mapped in the SFR space, but are not physically implemented. Reading or writing to a particular INDF register actually accesses its corresponding FSR register pair. A read from INDF1, for example, reads the data at the address indicated by FSR1H:FSR1L.

## 3.12.4 New Registers

### 3.12.4.1 BOTH

**TABLE 3-36: NEW REGISTERS FOR BOTH DEVICES**

Register	Purpose
INDFx	Virtual indirect register
FSRx	Holds target address of virtual register

#### 3.12.4.1.1 INDFx/FSRx

Because indirect addressing on both the PIC18 and enhanced mid-range core use the full address range, data RAM banking is not necessary. The FSR registers on the PIC18 form a 12-bit address while the enhanced mid-range forms a 16-bit address. This means that the PIC18 FSR provides access to the whole data memory range, while the enhanced mid-range gives access to all of the memory banks including read-only access program memory.

**FIGURE 3-15: ENHANCED MID-RANGE INDIRECT/DIRECT ADDRESSING**

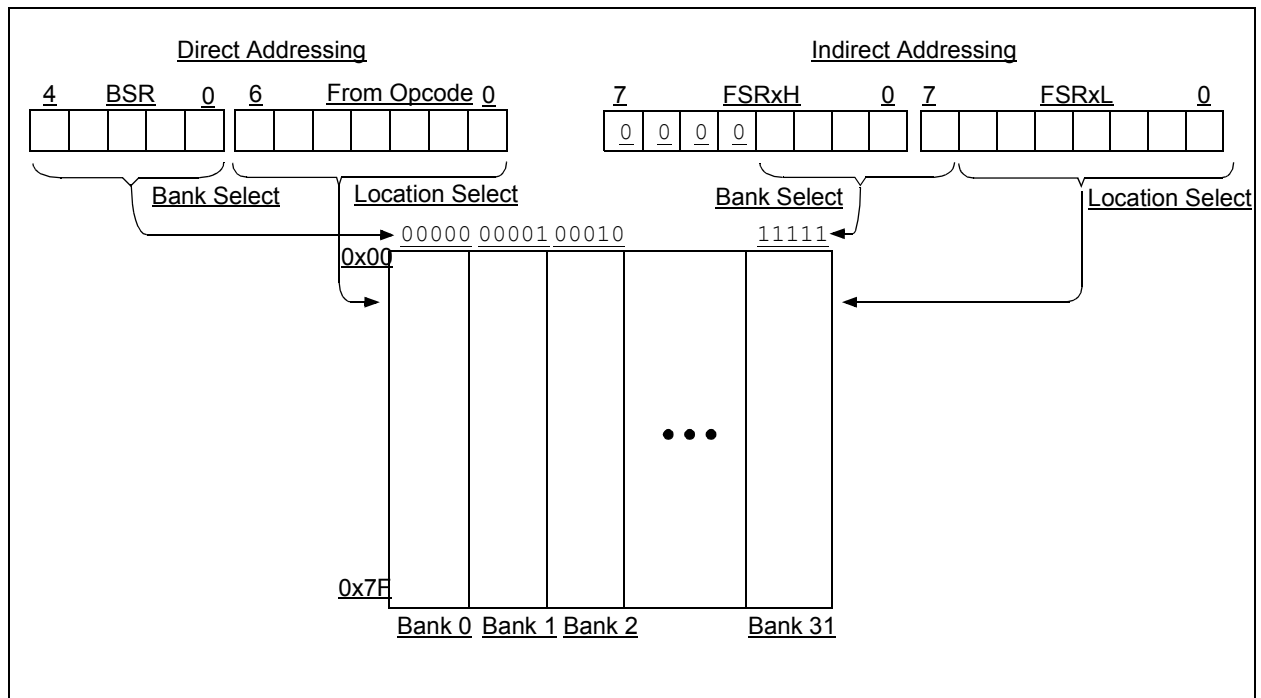

## 3.12.5 New Instructions

### 3.12.5.1 BOTH

**TABLE 3-37: NEW INSTRUCTIONS FOR BOTH DEVICES**

Instruction	English	Purpose
<code>incf</code>	Increment	Add a value of one

#### 3.12.5.1.1 `incf`

This increments a file register by a value of one.

# PICKit™ 3 Starter Kit User's Guide

## 3.12.6 Assembly Language

### 3.12.6.1 BOTH

#### EXAMPLE 3-43:

```
FilterInit:
  movlw   low Queue   ;point to the Queue holding the ADC values
  movwf   FSR0L
  movlw   high Queue
  movwf   FSR0H
```

Here, FSR0 is pointed towards the Queue location. [Figure 3-16](#) explains the code in [Figure 3-43](#). It is important to note that FSR0 is two bytes wide in order to address locations in program memory across multiple pages.

**FIGURE 3-16: BEFORE FILTERINIT IS CALLED**

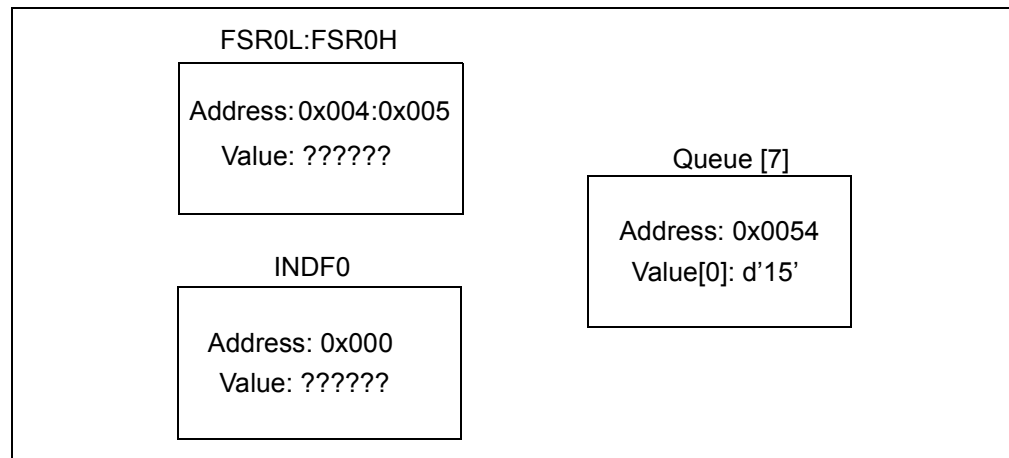

**FIGURE 3-17: AFTER FILTERINIT IS CALLED**

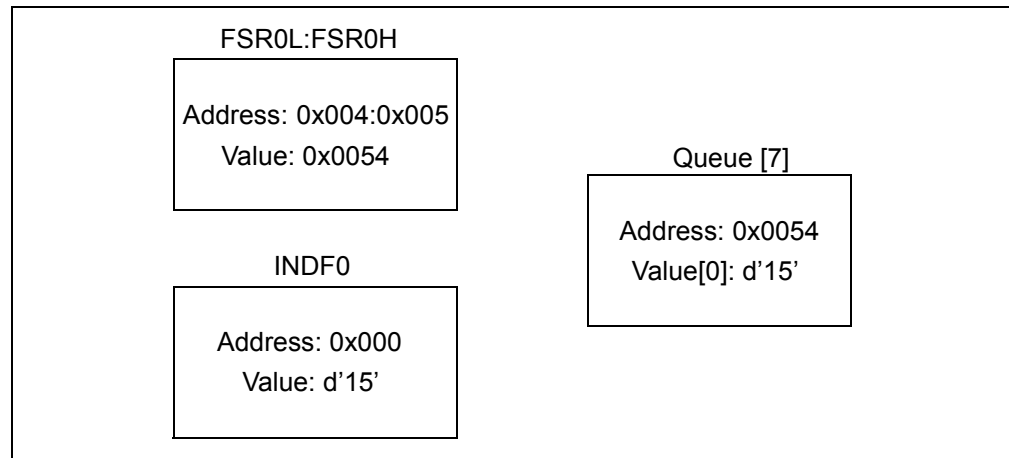

After `FilterInit` is called, the FSR0 register is pointing towards the first byte in queue. The INDF0 register can now be read/written to. Any affects on the INDF0 register will affect the value at the assigned address in the FSR0 register. An increment of FSR0 will point to the next byte in the Queue register. In this case, it is the second ADC reading.

```
rrcf RunningSum,w ; divide by 2 and copy to a version we can corrupt
```

A rotate or shift to the right is a quick method to divide by two.

## EQUATION 3-5:

```
Before Rotate right: b'00001010' = d'10'
After Rotate right:  b'00000101' = d'5'
```

### 3.12.7 C language

#### 3.12.7.1 BOTH

Pointers in 'C' are constructed by using the `INDF/FSR` pair on the PIC16/PIC18 to achieve the effect.

#### EXAMPLE 3-44:

```
while (1) {
    ptr_queue = &queue;                //point to the first byte in this array
                                        (RESET the pointer)
    for (i = NUM_READINGS; i != 0; i--){
        LATC = (average(ptr_queue) >> 4 ); //only want the 4 MSbs for 4 LEDs
        ptr_queue++;
    }
}
```

Similar to the assembly version, the main loop starts by resetting the pointer by pointing (referencing) to the first byte in the queue. Then, an ADC reading is taken and saved in the queue. LATC is then assigned the average of the queue. Remember that 'queue' is eight bytes wide, so it can hold eight samples of the ADC result (two LSbs of the result are not saved).

#### EXAMPLE 3-45:

```
unsigned char average(unsigned char *ptr) {
    unsigned char adc_value;

    _sum -= *ptr;                //subtract the current value out of the sum
    adc_value = adc();
    *ptr = adc_value;            //assign ADC value to the queue
    _sum += adc_value;           //add to the sum
    return (_sum/NUM_READINGS); //compute the average
}
```

The `average` function has the pointer to queue as a parameter. The `_sum` is a global variable which retains its value outside of this function. The current value in the running sum is subtracted. The asterisk means that its value is being used (dereferencing). A new ADC value is taken and added back into the running sum and the queue. The average reading is then returned to the main loop to be shifted onto the LED display.

There is a great deal of information about pointers for the 'C' language on the web. It is recommended that the reader look there for additional information.

## 3.13 LESSON 12: LOOK-UP TABLE

### 3.13.1 Intro

It is sometimes useful to implement a table to convert from one value to another. Expressed in a high-level language it might look like this:

#### EQUATION 3-6:

$$y = \text{function}(x);$$

That is, for every value of  $x$ , the function returns the corresponding  $y$  value. Look-up tables are a fast way to convert an input to meaningful data because the transfer function is pre-calculated and “looked up”, rather than calculated on the fly. A function that converts hexadecimal numbers to the ASCII equivalent is one such example.

The great benefit of using a look-up table is that abundant Flash memory is used to store constant values in lieu of the more limited RAM space. This allows greater flexibility and expands the memory capability of the program.

### 3.13.2 Hardware Effects

Gray coded binary will be reflected on the LEDs in accordance with the POT reading.

### 3.13.3 Summary

This lesson shows multiple ways to access program memory. The table simply converts from regular binary code to the gray code equivalent. Gray codes are frequently used in encoder applications to avoid wild jumps between states.

Binary encoders are typically implemented an opaque disk sensed by light sensors. Due to different threshold levels on different bits, bits may change at slightly different times, yielding momentary invalid results. Gray code prevents invalid transitions, because only one bit changes from one sequence to the next. The current code is correct until it transitions to the next.

The algorithm to convert between binary and Gray code is fairly complex. For a small number of bits, the table look-up is smaller and faster.

### 3.13.4 New Registers

#### 3.13.4.1 BOTH

**TABLE 3-38: NEW REGISTERS FOR BOTH DEVICES**

Register	Purpose
PCL	Program Counter (PC) Least Significant Byte
PCLATH	Write Buffer for the higher 7 bits of the Program Counter (8 bits for PIC18)

The PC addresses bytes in the program memory. Recall that the enhanced PIC16 has a Program Counter size of 15 bits and the PIC18 has a Program Counter of 21 bits. The two devices share the offset implementation rather closely still.

#### 3.13.4.1.1 PCL:

The low byte, known as the PCL register, is both readable and writable. The high byte, or PCH register is not directly readable or writable. Updates to this register are performed through the PCLATH register.

For the PIC18, the PC contains another register called PCU. This register contains the PIC18's PC<20:16> bits; it is also not directly readable or writable. Updates to the PCU register are performed through the PCLATU register.

## 3.13.4.1.2 PCLATH:

The contents of PCLATH and PCLATU (if using the PIC18) are transferred to the program counter by any operation that writes PCL. Similarly, the upper two bytes of the program counter are transferred to PCLATH and PCLATU by an operation that reads PCL. This is useful for the computed offsets to the PC that are used in this lesson.

For the PIC18, the PC increments by two to address sequential instructions in program memory. The PC increments by one in the enhanced mid-range core. This can be seen in previous lessons' assembly where there was a dollar sign (\$) with an offset literal. The enhanced core assembly uses a \$-1 to go back one valid program instruction in program memory. Likewise, the PIC18 uses a \$-2.

**FIGURE 3-18: FIVE SITUATIONS FOR THE LOADING OF THE PC ON THE ENHANCED MID-RANGE CORE**

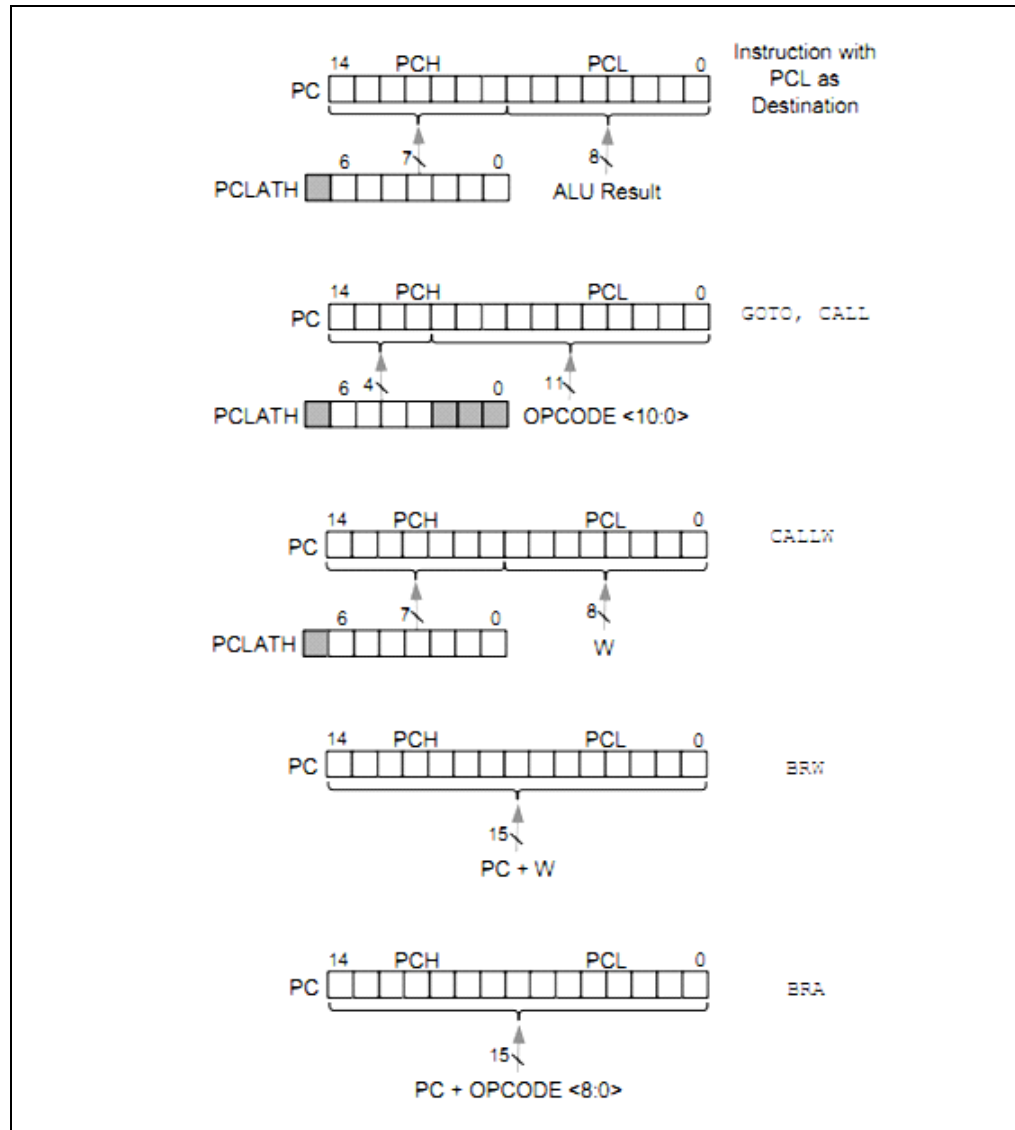

## 3.13.5 New Registers

### 3.13.5.1 ENHANCED MID-RANGE

**TABLE 3-39: NEW REGISTERS FOR ENHANCED MID-RANGE**

Register	Purpose
EEADR <sub>x</sub>	Address to read/write in program or EEPROM memory
EEDAT <sub>x</sub>	2-byte word that holds 14-bit data for read/write
EECON1	Control register for memory access

Flash program memory is also writable during normal operation. This is commonly referred to as “Self-modifying code” or “Self-write”. This is achievable by implementing a modified Harvard architecture.

#### 3.13.5.1.1 EEADR<sub>x</sub>/EEDAT<sub>x</sub>

When accessing the program memory block, the EEDATH:EEDATL register pair forms a 2-byte word that holds the 14-bit data for read/write, and the EEADRL and EEADRH registers form a 2-byte word that holds the 15-bit address of the program memory location being accessed.

#### 3.13.5.1.2 EECON1

Control bit EEPGD determines if the access will be a program or data memory access. When clear, any subsequent operations will operate on the EEPROM memory. When set, any subsequent operations will operate on the program memory. On Reset, EEPROM is selected by default.

Control bits RD and WR initiate read and write, respectively. These bits cannot be cleared, only set, in software. They are cleared in hardware at completion of the read or write operation. The inability to clear the WR bit in software prevents the accidental, premature termination of a write operation.

The WREN bit, when set, will allow a write operation to occur. On power-up, the WREN bit is clear.

### 3.13.5.2 PIC18

**TABLE 3-40: NEW REGISTERS FOR PIC18**

Register	Purpose
TBLPTR	Points to a byte address in program space
TABLAT	Holds 8-bit data from program space

#### 3.13.5.2.1 TBLPTR

The Table Pointer (TBLPTR) points to a byte address in program space. Executing TBLRD places the byte pointed to into TABLAT. In addition, TBLPTR can be modified automatically for the next table read operation.

The TBLPTR is comprised of three SFR registers: Table Pointer Upper Byte, Table Pointer High Byte and Table Pointer Low Byte (TBLPTRU:TBLPTRH:TBLPTRL). These three registers join to form a 22-bit wide pointer.

#### 3.13.5.2.2 TABLAT

The Table Latch (TABLAT) is an 8-bit register mapped into the SFR space. The Table Latch register is used to hold 8-bit data during data transfers between program memory and data RAM.

## 3.13.6 New Instructions:

### 3.13.6.1 BOTH:

**TABLE 3-41: NEW INSTRUCTIONS FOR BOTH DEVICES**

Instruction	English	Purpose
<code>retlw</code>	Return with literal in WREG	Table look-ups

#### 3.13.6.1.1 `retlw`

The WREG register is loaded with the 8-bit literal specified as 8 bits in the instruction word. The program counter is then loaded from the top of the stack (the return address). Recall that the PIC MCU utilizes a **modified** Harvard architecture. It is modified because it allows the contents of the instruction memory to be accessed as if it were data.

### 3.13.6.2 ENHANCED MID-RANGE

**TABLE 3-42: NEW INSTRUCTIONS FOR ENHANCED MID-RANGE**

Instruction	English	Purpose
<code>moviw</code>	Move INDFx to WREG	Shorthand <code>movlw</code> with increment/decrement
<code>brw</code>	Relative with WREG	Local jump table

#### 3.13.6.2.1 `moviw`

This instruction is used to move data between WREG and one of the indirect registers (INDFn). Before/after this move, the pointer (FSRn) is updated by pre/post incrementing/decrementing it.

Recall that the INDFn registers are not physical registers. Any instruction that accesses an INDFn register actually accesses the register at the address specified by the FSRn. FSRn is limited to the range 0000h-FFFFh. Incrementing/decrementing it beyond these bounds will cause it to wrap around.

#### 3.13.6.2.2 `brw`

The `brw`, relative branch, instruction adds an offset to the PC. `brw` allows relocatable code and codes that cross page boundaries. This adds the contents of WREG (unsigned) to the PC. Since the PC will have incremented to fetch the next instruction, the new address will be  $PC + 1 + (WREG)$ . The designer does not need to worry about program memory boundaries being crossed when using this.

### 3.13.6.3 PIC18:

**TABLE 3-43: NEW INSTRUCTIONS FOR PIC18**

Instruction	English	Purpose
<code>tblrd*</code>	Table Read	Table look-up data retrieval

#### 3.13.6.3.1 `tblrd`

This instruction is used to read the contents of program memory. To address the program memory, a three-byte pointer called Table Pointer is used. All three bytes of Table Pointer must be setup before executing the `tblrd*` instruction.

**FIGURE 3-19: TABLE POINTER USED TO READ ONE BYTE OF DATA – ANSWER IS REFLECTED IN ‘TABLAT’**

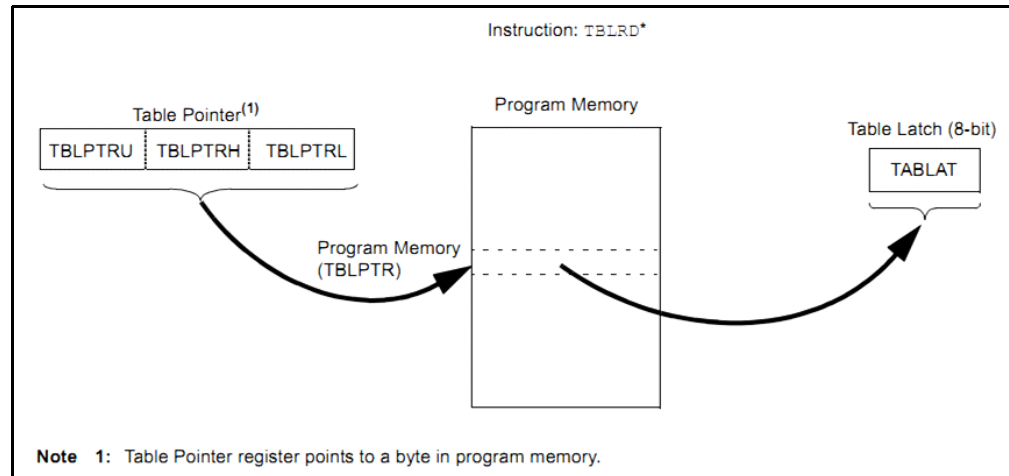

### 3.13.7 Assembly Language

#### 3.13.7.1 ENHANCED MID-RANGE

There are three methods of accessing constants in program memory:

1. Computed `goto`
2. Indirect Addressing
3. Table Reads

The code will implement 3 different ways to utilize these methods:

1. Computed `goto`
  - a) **Program Counter**
  - b) **BRW instruction**
2. Indirect Addressing
  - a) **FSR/INDF**
3. Table Reads
  - a) **EECON/EEADAT/EEADR SFRs**

The third method can return the full 14 bits of the program memory words while the first two only return an 8-bit byte. This lesson demonstrates all three methods, but utilizes only the lower 8-bits of the data retrieved by method three.

##### 3.13.7.1.1 Program Counter

Calling the look-up table has a limitation: if the table falls across a 256-byte page boundary, or the index into the table exceeds the table bounds, then it will jump to a location out of the table.

Good programming practices dictate a few additional instructions for our example: first, since the table is only sixteen entries, make sure a number no larger than 16 is passed in. The simplest way to do this is to logically AND the contents of WREG before modifying PCL:

```
ANDLW 0x0F
```

More complex error recovery schemes may be appropriate, depending on your application.

In addition, there are some nuances to be aware of, should the table cross a 256-word boundary. The Program Counter is 15 bits wide, but only the lower eight bits are represented in PCL. The remaining five bits are stored in PCLATH. However, an overflow of

the lower eight bits is not automatically carried over into PCLATH. Because of this, be sure to check the Carry flag in the STATUS register immediately after the table offset addition, so that the PCLATH can be modified accordingly.

## EXAMPLE 3-46:

```

;Using the Program Counter (PC) directly
movlw   high TableStart   ; get high order part of the beginning of the table
movwf   PCLATH
movlw   low TableStart    ; load starting address of table
addwf   temp,w            ; add offset from ADC conversion
btfsc   STATUS,C          ; did it overflow?
incf    PCLATH,f          ; yes: increment PCLATH
movwf   PCL               ; modify PCL

```

### 3.13.7.1.2 brw instruction

Once the ADC value is loaded into WREG, the Program Counter can be modified in a somewhat more indirect method than above. The program counter will be offset by the value in the working register. This is the most efficient method for small tables.

## EXAMPLE 3-47:

```

EnhancedMethod:
    brw                               ;jumps ahead by the amount currently in wreg
TableStart:
    retlw    b'0000'                  ; 0
.....

```

### 3.13.7.1.3 Indirect Addressing

The FSRx/INDFx pair can be used nicely in this example. Any large table look-ups should follow this method.

The below code loads the starting address of the gray code table. Then, the ADC value is added into FSR0 as the offset, which points to the corresponding gray code value.

## EXAMPLE 3-48:

```

movlw   high TableStart ; get high order part of the beginning of the table
movwf   FSR0H
movlw   low TableStart  ; get lower order part of the table
addwf   temp, w         ; add offset from ADC conversion
btfsc   STATUS, C       ; did it overflow?
incf    FSR0H, f        ; yes: increment high byte
movwf   FSR0L           ; modify lower byte
moviw   FSR0++          ; move the value that FSR0 is pointing to into wreg
return                                ; grey code now in wreg, return to MainLoop

```

### 3.13.7.1.4 Table Reads

This method uses special SFRs that are used strictly for Flash program memory reads/writes. Writing to program memory is more complex and restrictive, but reading a single word from program memory is straightforward.

# PICKit™ 3 Starter Kit User's Guide

## EXAMPLE 3-49:

```
banksel    EEADRL          ; bank 3
movlw     high TableStart ;
movwf     EEADRH          ; Store MSb of address
movlw     low TableStart  ;
addwf     temp, w
btfsc    STATUS, C
incf     EEADRH, f
movwf     EEADRL          ; Store LSb of address

bcf      EECON1, CFGS     ; Do not select Configuration Space
bsf      EECON1, EEPGD    ; Select Program Memory
bcf      INTCON, GIE      ; Disable interrupts
bsf      EECON1, RD       ; Initiate read
nop      ; Executed
nop      ; Ignored
bsf      INTCON, GIE      ; Restore interrupts
movf     EEDATL, w       ; Get LSb of word
return

;movwf   PROG_DATA_LO    ; Store in user location
;movf    EEDATH,W         ; Get MSb of word
;movwf   PROG_DATA_HI    ; Store in user location
```

This code reads a single byte in program memory. Only the lower eight bits are used. First, the high address of the table is loaded into EEADRH. The lower address is not assigned immediately, but rather after adding the offset (ADC result) into the address first. This is to ensure that the added offset to the low address will not cause an undetected overflow (255->0).

### 3.13.7.2 PIC18

The PIC18 supports two methods to access constants in program memory:

1. Computed `GOTO`
2. Table Reads

The code will implement two different ways to utilize these methods:

1. Computed `GOTO`
  - Program Counter
2. Table Reads
  - `tblrd` instruction

The PIC18 can also use the `EECON/EEDAT/EEADR` SFRs for table reads. Please see the enhanced core implementation in assembly for more information.

In order to read and write program memory, there are two operations that allow the processor to move bytes between the program memory space and the data RAM:

- Table Read (`tblrd`)
- Table Write (`tblwt`)

This lesson will only perform table reads and hence use the `tblrd` instruction.

The program memory space is 16 bits wide, while the data RAM space is 8 bits wide. Table reads and table writes move data between these two memory spaces through an 8-bit register (`TABLAT`).

The table read operation retrieves one byte of data directly from program memory and places it into the `TABLAT` register.

## 3.13.7.3 PROGRAM COUNTER

Like the Enhanced Core implementation, the differences being that PCLATU is used to address the full 21 bits, and that the ADC value is multiplied by two, because the 16-bit PIC18 instructions are byte-addressable on the even addresses.

### EXAMPLE 3-50:

```
;Using the Program Counter (PC) directly
movlw    upper TableStart    ; move upper part
movwf    PCLATU
movlw    high TableStart     ; get high order part of the beginning of the table
movwf    PCLATH
movlw    low TableStart      ; load starting address of table
rlcf     temp, f             ; multiply by 2 by shifting to the left (remember
                             ; that the PIC18 has 16bit program counter)
addwf    temp,w              ; add offset from ADC conversion
btfsc    STATUS,C            ; did it overflow?
incf     PCLATH,f            ; yes: increment PCLATH
movwf    PCL                 ; modify PCL
```

## 3.13.7.4 TABLE READ

This code is identical to the above using the Program Counter except that it is using the TBLPTR registers and not the program counter directly. Also, note how a multiply by two is performed on the temporary register where the ADC result is stored. This is only necessary when the data is stored in the lower bytes of the program words. When data is stored as bytes, then the multiply by two for table access is unnecessary, because program memory is byte-addressable. Any single rotate to the left performs a multiple of two and a rotate to the right is a division of two.

### EXAMPLE 3-51:

```
movlw    upper TableStart    ; Load TBLPTR with the base
movwf    TBLPTRU              ; address of the word
movlw    high TableStart
movwf    TBLPTRH
movlw    low TableStart
rlcf     temp, f              ;multiply by 2 by shifting to the left
addwf    temp, w
btfsc    STATUS, C
incf     TBLPTRH, f
movwf    TBLPTRL
```

Once properly configured, a read can be performed.

### EXAMPLE 3-52:

```
READ_WORD:
tblrd*           ; read into TABLAT
movf    TABLAT, w ; get data
return
```

The code returns to the main loop with the gray code in WREG.

## 3.13.8 C Language

### 3.13.8.1 BOTH

Like usual, the 'C' implementation is rather easy and much more readable.

A look-up table is achieved by creating an array and declaring it as a constant, so that the compiler places it into program space and not data space.

# PICkit™ 3 Starter Kit User's Guide

## EXAMPLE 3-53:

```
const unsigned char gray_code[] = { //lookup table for binary->gray code
    0b0000,0b0001,0b0011,0b0010,0b0110,
    0b0111,0b0101,0b0100,0b1100,0b1101,
    0b1111,0b1110,0b1010,0b1011,0b1001,
    0b1000
};
```

For PIC18 devices, the compiler will recognize the “char” type as a byte and assign two byte addressable data points per program memory word. Notice the data space difference if this ‘const’ keyword is forgone.

## FIGURE 3-20: DECLARED AS A CONSTANT

Memory Summary:						
Program space	used	7Eh	( 126)	of	4000h bytes	( 0.8%)
Data space	used	1h	( 1)	of	1A0h bytes	( 0.2%)

## FIGURE 3-21: NOT DECLARED AS A CONSTANT

Memory Summary:						
Program space	used	9Ch	( 156)	of	4000h bytes	( 1.0%)
Data space	used	11h	( 17)	of	1A0h bytes	( 4.1%)

The compiler placed 16 more bytes into data space (as it should) when the `const` keyword was omitted. With the keyword in place, notice how only one byte of RAM is used. This one byte is used in `main`, `adc_value`, which holds the top eight Most Significant bits.

Notice how much more space there is in program memory than in data memory. Sixteen bytes of RAM accounts for 4% of the total available space while adding the array into Flash only adds an additional 2% of used space.

The main loop then uses the ADC value as the offset into the array which will return the correct gray code equivalent.

## EXAMPLE 3-54:

```
while(1){
    adc_value = adc();           //get the ADC value from the POT
    adc_value >> = 4;           //save only the top 4 MSBs
    LATC = gray_code[adc_value]; //convert to Gray Code and display on the LEDs
}
```

## 3.14 LESSON 13: EEPROM

### 3.14.1 Introduction

This lesson provides code for writing and reading a single byte onto the on-board EEPROM. EEPROM is nonvolatile memory, meaning that it does not lose its value when power is shut off. This is unlike RAM, which will lose its value when no power is applied. The EEPROM is useful for storing variables that must still be present during no power. It is also convenient to use if the entire RAM space is used up. Both the PIC16F1829 and the PIC18F14K22 have 256 bytes of EEPROM available. Writes and reads to the EEPROM are relatively quick, and are much faster than program memory operations.

### 3.14.2 Hardware Effects

Press the switch to save the LED pattern, and then disconnect the power. When power is then applied again, the program will start with that same LED pattern lit.

### 3.14.3 Summary

When the lesson is first programmed, no LEDs will light up, even with movement of the POT. When the switch is pressed, the LED corresponding to the ADC reading at that instant will be lit, and the PIC MCU will go to Sleep until the switch is pressed again. Each press of the switch saves the ADC value into EEPROM. The PIC MCU uses interrupts to wake-up from Sleep, take an ADC reading, save to EEPROM, and then goes back to Sleep.

**FIGURE 3-22: PROGRAM FLOW**

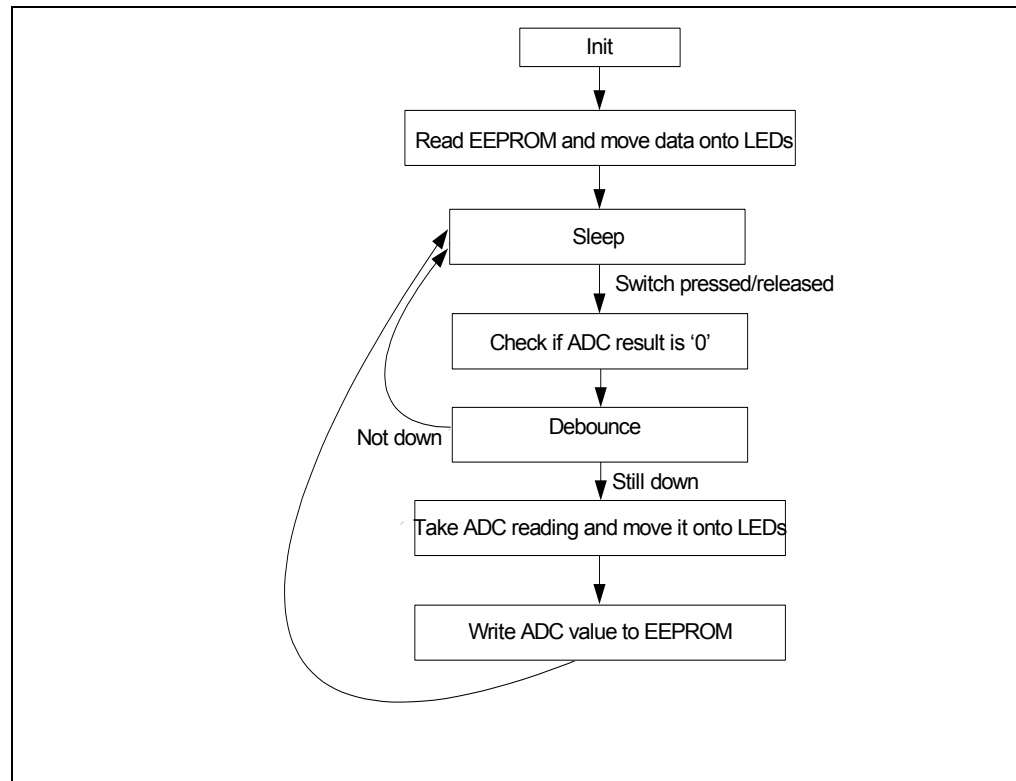

## 3.14.4 New Registers

### 3.14.4.1 BOTH

**TABLE 3-44: NEW REGISTERS FOR BOTH DEVICES**

Register	Purpose
EECON2	Performs the required write sequence

#### 3.14.4.1.1 EECON2

In order to write to EEPROM, a special sequence must be performed on EECON2. This register is only used for EEPROM writes and nothing else.

## 3.14.5 New Instructions

### 3.14.5.1 BOTH

**TABLE 3-45: NEW INSTRUCTIONS FOR BOTH DEVICES**

Instruction	English	Purpose
SLEEP	Go to Sleep	Low-power operation

#### 3.14.5.1.1 SLEEP

When the `SLEEP` instruction is executed, the processor is put into Sleep mode with the oscillator stopped. While sleeping, the processor consumes minimal current (uA levels). During Sleep, some peripherals and interrupts continue to operate.

Upon entering Sleep mode, the following conditions exist:

1. CPU clock is disabled.
2. 31 kHz LFINTOSC is unaffected and peripherals that operate from it may continue operation in Sleep.
3. Timer1 external oscillator is unaffected, and peripherals that operate from it may continue operation in Sleep.
4. ADC is unaffected, if the dedicated FRC clock is selected.
5. I/O ports maintain the status they had before.
6. `SLEEP` was executed (driving high, low or high-impedance).
7. Resets other than WDT are not affected by Sleep mode.

The reader should refer to individual peripheral chapters for more details on peripheral operation during Sleep.

The interrupt-on-change that both devices utilize in this lesson will wake the processor from Sleep to perform the EEPROM write and ADC reading.

## 3.14.6 Assembly Language

### 3.14.6.1 BOTH

The code only reads and writes one byte from EEPROM. The address, 0x00, is defined in the first few lines of the program. Much like the previous lesson, EECON1/EEADRL/EEDAT is used throughout for all memory writes/reads.

An EEPROM write requires that a unique sequence is written to the EECON2 virtual register.

**EXAMPLE 3-55:**

```
;REQUIRED SEQUENCE for EEPROM write
movlw    0x55
movwf    EECON2
movlw    0xAA
movwf    EECON2
bsf      EECON1, WR      ;begin write
```

When the WR bit is set, it remains set until the write to EEPROM is complete.

### 3.14.7 C Language

#### 3.14.7.1 BOTH

There are two functions that the XC8 compiler provides, which greatly simplify EEPROM reads and writes.

**EXAMPLE 3-56:**

```
eeeprom_read(<addr>)
eeeprom_write(<addr>, <value>);
```

Use this to read and write single bytes from EEPROM.

# PICKit™ 3 Starter Kit User's Guide

---

NOTES:

## Appendix A. Block Diagram and MPLAB® X Shortcuts

FIGURE A-1: LOW PIN COUNT BOARD SCHEMATIC

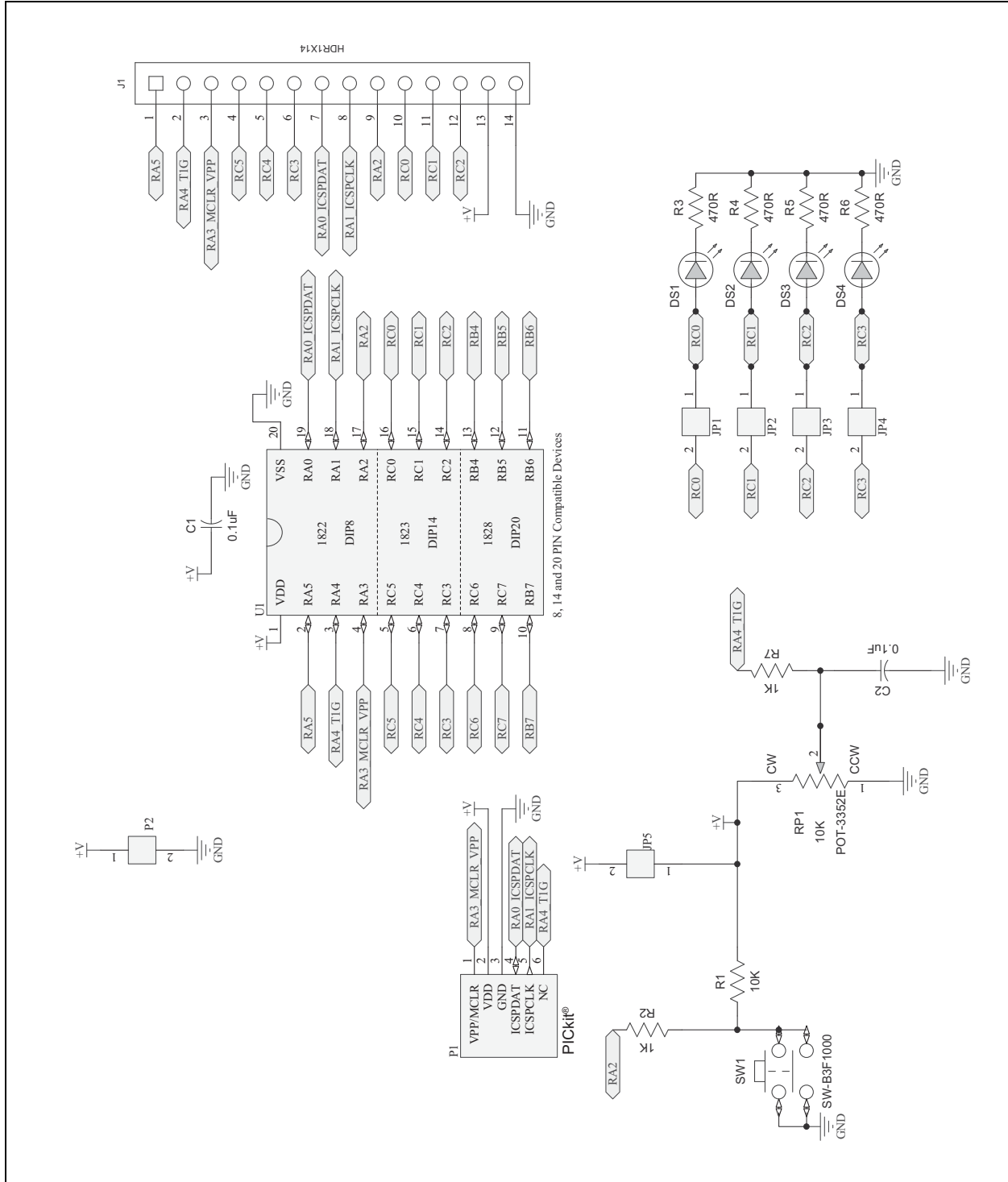

# PICkit™ 3 Starter Kit User's Guide

---

## A.1 USEFUL MPLAB® X SHORTCUTS

MPLAB X provides several new features to the MPLAB IDE. It is based on the existing development platform, Netbeans. The following is a list of useful shortcuts available while developing code:

1. ALT+SHIFT+'F'
    - a) Auto Format code
  2. CTRL+E
    - a) Delete the currently selected line and move up the next
  3. CTRL+SEMICOLON
    - a) Append a semicolon to the end of the currently selected line
  4. CTR+SHIFT+UP
    - a) Copy the selected line to a new line below it
    - b) Supports multiple lines via highlighting
- Custom macros can be created by going to *edit->start macro recording*
  - Hover over any function call and hold CTRL to go to that function definition.

Visit [netbeans.com](http://netbeans.com) to learn more shortcuts. The forums will provide a great deal of help as well.

## A.2 FINDING REGISTER NAMES

All of the register definitions are defined in a header file that must be included at the top of each source file. For these lessons, the expected system directory locations are as follows:

Assembler (MPASM):

1. C:\Program Files\Microchip\MPASM Suite\P18F14K22.inc
  2. C:\Program Files\Microchip\MPASM Suite\P16F1829.inc
- XC8
1. C:\Program Files\microchip\xc8\v1.00\include\pic16f1829.h
  2. C:\Program Files\microchip\xc8\v1.00\include\pic18f14K22.h

## A.3 PIC MCU ASSEMBLY CODING PRACTICES:

In general, assembly should be commented profusely due to the complexity and obscurity of the language.

- Write to the latch, read from the port.
- Use bit operations (*bcf/bsf*) when modifying important parts that should be emphasized instead of a simple *movlw*.
- Put the Interrupt Service Routine (ISR) as the last function.
- Assembler directives should be in lowercase:  
`res, org, #define, #include, banksel, ...`
- Labels should be descriptive and should have a colon.
- Do not hard code addresses. Use `clblock/endc` (non-linker) or `#pragma udata sections` (linker) to allow assembler or linker to assign variable addresses.

## EXAMPLE A-1:

```
Bad:
    #define flowRate 0x20
    flowRate equ 0x20
Good:
    Cblock 0x20
        flowRate
        flowTotal
    endc
```

# PICKit™ 3 Starter Kit User's Guide

---

NOTES:

# PICKit™ 3 Starter Kit Board User's Guide

---

---

NOTES:



# MICROCHIP

## Worldwide Sales and Service

### AMERICAS

**Corporate Office**  
2355 West Chandler Blvd.  
Chandler, AZ 85224-6199  
Tel: 480-792-7200  
Fax: 480-792-7277  
Technical Support:  
<http://www.microchip.com/support>  
Web Address:  
[www.microchip.com](http://www.microchip.com)

**Atlanta**  
Duluth, GA  
Tel: 678-957-9614  
Fax: 678-957-1455

**Boston**  
Westborough, MA  
Tel: 774-760-0087  
Fax: 774-760-0088

**Chicago**  
Itasca, IL  
Tel: 630-285-0071  
Fax: 630-285-0075

**Cleveland**  
Independence, OH  
Tel: 216-447-0464  
Fax: 216-447-0643

**Dallas**  
Addison, TX  
Tel: 972-818-7423  
Fax: 972-818-2924

**Detroit**  
Farmington Hills, MI  
Tel: 248-538-2250  
Fax: 248-538-2260

**Indianapolis**  
Noblesville, IN  
Tel: 317-773-8323  
Fax: 317-773-5453

**Los Angeles**  
Mission Viejo, CA  
Tel: 949-462-9523  
Fax: 949-462-9608

**Santa Clara**  
Santa Clara, CA  
Tel: 408-961-6444  
Fax: 408-961-6445

**Toronto**  
Mississauga, Ontario,  
Canada  
Tel: 905-673-0699  
Fax: 905-673-6509

### ASIA/PACIFIC

**Asia Pacific Office**  
Suites 3707-14, 37th Floor  
Tower 6, The Gateway  
Harbour City, Kowloon  
Hong Kong  
Tel: 852-2401-1200  
Fax: 852-2401-3431

**Australia - Sydney**  
Tel: 61-2-9868-6733  
Fax: 61-2-9868-6755

**China - Beijing**  
Tel: 86-10-8569-7000  
Fax: 86-10-8528-2104

**China - Chengdu**  
Tel: 86-28-8665-5511  
Fax: 86-28-8665-7889

**China - Chongqing**  
Tel: 86-23-8980-9588  
Fax: 86-23-8980-9500

**China - Hangzhou**  
Tel: 86-571-2819-3187  
Fax: 86-571-2819-3189

**China - Hong Kong SAR**  
Tel: 852-2401-1200  
Fax: 852-2401-3431

**China - Nanjing**  
Tel: 86-25-8473-2460  
Fax: 86-25-8473-2470

**China - Qingdao**  
Tel: 86-532-8502-7355  
Fax: 86-532-8502-7205

**China - Shanghai**  
Tel: 86-21-5407-5533  
Fax: 86-21-5407-5066

**China - Shenyang**  
Tel: 86-24-2334-2829  
Fax: 86-24-2334-2393

**China - Shenzhen**  
Tel: 86-755-8203-2660  
Fax: 86-755-8203-1760

**China - Wuhan**  
Tel: 86-27-5980-5300  
Fax: 86-27-5980-5118

**China - Xian**  
Tel: 86-29-8833-7252  
Fax: 86-29-8833-7256

**China - Xiamen**  
Tel: 86-592-2388138  
Fax: 86-592-2388130

**China - Zhuhai**  
Tel: 86-756-3210040  
Fax: 86-756-3210049

### ASIA/PACIFIC

**India - Bangalore**  
Tel: 91-80-3090-4444  
Fax: 91-80-3090-4123

**India - New Delhi**  
Tel: 91-11-4160-8631  
Fax: 91-11-4160-8632

**India - Pune**  
Tel: 91-20-2566-1512  
Fax: 91-20-2566-1513

**Japan - Osaka**  
Tel: 81-66-152-7160  
Fax: 81-66-152-9310

**Japan - Yokohama**  
Tel: 81-45-471-6166  
Fax: 81-45-471-6122

**Korea - Daegu**  
Tel: 82-53-744-4301  
Fax: 82-53-744-4302

**Korea - Seoul**  
Tel: 82-2-554-7200  
Fax: 82-2-558-5932 or  
82-2-558-5934

**Malaysia - Kuala Lumpur**  
Tel: 60-3-6201-9857  
Fax: 60-3-6201-9859

**Malaysia - Penang**  
Tel: 60-4-227-8870  
Fax: 60-4-227-4068

**Philippines - Manila**  
Tel: 63-2-634-9065  
Fax: 63-2-634-9069

**Singapore**  
Tel: 65-6334-8870  
Fax: 65-6334-8850

**Taiwan - Hsin Chu**  
Tel: 886-3-5778-366  
Fax: 886-3-5770-955

**Taiwan - Kaohsiung**  
Tel: 886-7-536-4818  
Fax: 886-7-330-9305

**Taiwan - Taipei**  
Tel: 886-2-2500-6610  
Fax: 886-2-2508-0102

**Thailand - Bangkok**  
Tel: 66-2-694-1351  
Fax: 66-2-694-1350

### EUROPE

**Austria - Wels**  
Tel: 43-7242-2244-39  
Fax: 43-7242-2244-393

**Denmark - Copenhagen**  
Tel: 45-4450-2828  
Fax: 45-4485-2829

**France - Paris**  
Tel: 33-1-69-53-63-20  
Fax: 33-1-69-30-90-79

**Germany - Munich**  
Tel: 49-89-627-144-0  
Fax: 49-89-627-144-44

**Italy - Milan**  
Tel: 39-0331-742611  
Fax: 39-0331-466781

**Netherlands - Drunen**  
Tel: 31-416-690399  
Fax: 31-416-690340

**Spain - Madrid**  
Tel: 34-91-708-08-90  
Fax: 34-91-708-08-91

**UK - Wokingham**  
Tel: 44-118-921-5869  
Fax: 44-118-921-5820

11/29/11