

## IN THIS ISSUE

### PAGE 1

[dsPIC® DSCs for SMPS and Digital Power Conversion](#)

### PAGE 2

[Microchip Ships 500,000<sup>th</sup> Development Tool](#)

### PAGE 3

[MATLAB®, Simulink® and Real-Time Workshop® Software Plug-ins Added to MPLAB IDE Version 7.51](#)

### PAGE 4

[High-performance 8-bit MCUs with High Levels of Integration at 3V for Cost-sensitive Applications](#)

### PAGE 5

[Join Microchip at ESC!](#)

### PAGE 6

[General-purpose, Small PIC® MCU Family Expands](#)

### PAGE 7

[Bit Bashing: Transformerless Power Supply Design with High-voltage MCUs](#)

### PAGE 8

[Communication is Vital: Excerpt from Driving Excellence](#)

### PAGE 9

[New MCP3909 Energy-measurement IC and Reference Design](#)

### PAGE 10

[Production Programming through microchipDIRECT](#)

[Software for Sale: Download Capability through microchipDIRECT](#)

### PAGE 11

[Microchip Around Town](#)

### PAGE 12

[What's New in Microchip Literature?](#)

### PAGE 13

[Web Site Highlights](#)

## Looking to bring the benefits of digital power conversion – including higher power density, lower cost features and accelerated innovation – to your product?

**Microchip's dsPIC® Digital Signal Controllers (DSCs) for Switch Mode Power Supplies (SMPS) and digital power conversion target applications in AC/DC power supplies, power factor correction, DC/DC converters, uninterruptible power supplies, power inverters, digital lighting and advanced battery chargers.**

By using digital loop control to implement power-conversion products, you can realize many benefits for your design and business, including the ability to perform the power-conversion control via reprogrammable software with the performance and features of the Microchip DSC solutions. Benefits include:

### Increased Power Density

- Reduce system size via component count and size reduction
- Smaller Heatsinks via improved efficiency
- Smaller Magnetics via advanced switching techniques

### Lower Cost, Improved Time to Market & Ease of Manufacturing

- Feature-rich designs with fewer components
- Power factor correction performed by DSC software
- Complexity designing for component tolerance/drift reduced
- Fewer hardware platforms support varied end products through software
- Manufacturing-line tuning eliminated – component tolerance issues reduced
- End-of-line configuration possible (load limits, communication protocols, etc.)
- Improved self-test capability simplifies/speeds product testing

### New, Cost-Effective Features

- Adapt to changing load (capacitive, inductive, resistive, current demands)
- Better transient response specifications – not limited to linear techniques
- Managed voltage transitions eliminate “overspecified” components

### Improved Reliability

- Supplies can be restricted from operating out of specification
- Fewer components help reliability
- Lower cost redundancy options

### Protect Intellectual Property

- Key innovative IP implemented in secured Flash software



### GOING DIGITAL THE EASY WAY!

Learn the technical aspects of digital power conversion and SMPS design with hands-on training and FREE web seminars from Microchip. Get a better understanding about how the dsPIC DSCs can be used to implement digital power conversion products. Visit our web site for more details!

### WIN STUFF IN OUR DIGITAL POWER CONTEST

Complete the online Digital Power Contest Entry Form and **ENTER TO WIN** a **dsPIC DSC SMPS Development System**. This \$350.00 prize (awarded weekly) includes:

- dsPICDEM™ SMPS Buck Development Board (DM300023)
- MPLAB® ICD 2 module (DV164007)
- Digital multimeter

We are also giving away an Apple® iPod® mobile digital media player to one lucky grand prize winner!

With your completed entry form, you will receive a \$50 discount off our **dsPICDEM™ SMPS Buck Development Board** (DM300023) to help you get started with your SMPS and power-conversions designs.

For more information, visit [www.microchip.com/SMPS](http://www.microchip.com/SMPS)

# Microchip Technology Ships 500,000<sup>th</sup> Development Tool!

## Australia's Ness Security Products receives 500,000<sup>th</sup> development tool shipped from Microchip!

Microchip development tools are software and hardware components used to design applications with Microchip devices. Our tools are used by embedded design engineers looking to simplify code development while reducing design-software costs. Microchip's recent announcement that it shipped its five billionth PIC<sup>®</sup> MCU to Chinese power-meter maker Jiangsu Linyang Electronics – as that **there is one development tool for every 10,000 devices delivered worldwide.**

***“Shipping our 500,000<sup>th</sup> development tool demonstrates our commitment to driving improvement and innovation. This milestone represents the continued success of our 8-bit PIC microcontrollers and analog products, as well as overwhelming enthusiasm for our 16-bit family of dsPIC<sup>®</sup> Digital Signal Controllers (DSCs) and PIC24 microcontrollers. We are continuing to deliver the best valued tools and best technical support in the industry.”***

– Mitch Little, vice president of Worldwide Sales and Applications at Microchip



The 500,000<sup>th</sup> development tool shipped is the MPLAB<sup>®</sup> PM3 Universal Device Programmer. This tool is easy to use and operates with a PC or as a stand-alone unit to program Microchip's entire line of PIC microcontrollers as well as the latest dsPIC DSCs. This universality continues Microchip's practice of providing tools that are applicable across product family lines.

Included with the MPLAB PM3 Universal Device Programmer is the highly popular, and free, MPLAB Integrated Development Environment (IDE). With this tool, new design activities are simpler to launch, faster to market and can leverage the MPLAB IDE's unified, easy-to-use interface, which accommodates a generous array of software and hardware components.

“From evaluation kits, programmers, in-circuit debuggers to state-of-the art in-circuit emulators that run full speed with tomorrow's highest speed technologies, the development tools from Microchip offer simplicity, power and affordability,” said Derek Carlson, vice president of Development Tools at Microchip Technology. “Microchip stands alone among semiconductor companies by offering a low-cost, universal, and truly integrated development environment for 8- and 16-bit microcontrollers, and 16-bit digital signal controllers, ranging from 6-pin to over 100-pin devices.”

Microchip's 55,000 customers in more than 65 countries would agree. Creed Huddleston, president of Real-Time by Design, LLC, and author of the new book *Intelligent Sensor Design Using the Microchip dsPIC<sup>®</sup> DSC*, utilizes Microchip tools in his daily work as an embedded design consultant. Huddleston observes that, “the primary reason for using Microchip development tools is that they are readily available, inexpensive and there are user forums available to get help when the inevitable questions or problems arise. Microchip does a great job of providing low-cost and highly valued tools.”

For more information about Microchip's development tool, please visit [www.microchip.com/developmenttools](http://www.microchip.com/developmenttools)

[RETURN TO FRONT PAGE](#)

# MATLAB®, Simulink® and Real-Time Workshop® Software Plug-ins Added to MPLAB IDE Version 7.51

## Microchip's popular MPLAB® Integrated Development Environment (IDE) now features a free plug-in for The MathWorks MATLAB®, Simulink® and Real-time Workshop® Embedded Coder modeling and code-generation programs.

The MathWorks is the world's leading developer of technical computing and Model-Based Design software for engineers and scientists in industry, government, and education. With an extensive product set based on MATLAB and Simulink, The MathWorks provides software and services to solve challenging problems and accelerate innovation in automotive, aerospace, communications, financial services, biotechnology, electronics, instrumentation, process, and other industries. The MathWorks was founded in 1984 and employs more than 1,600 people worldwide, with headquarters in Natick, Massachusetts.

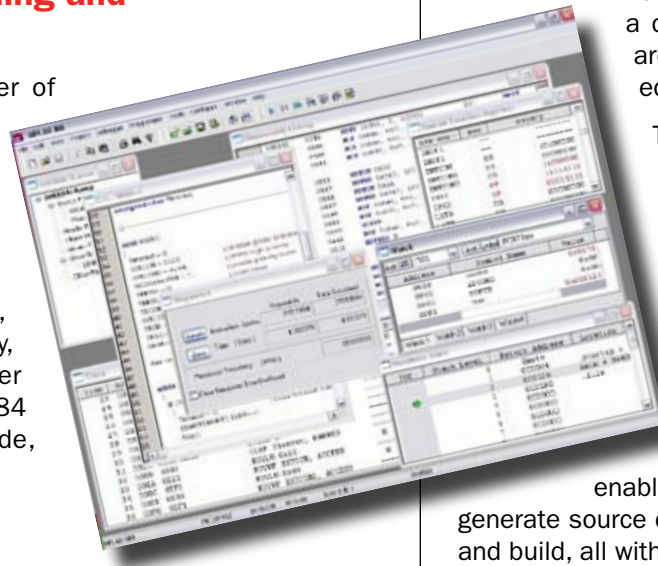

MATLAB is a high-level technical computing language and interactive environment for algorithm development, data visualization, data analysis, and numeric computation. Simulink is a platform for multi-domain simulation and Model-Based Design of dynamic systems. With Simulink, designers can quickly create, model and maintain a detailed block diagram of the system, using a comprehensive set of predefined blocks. MATLAB and Simulink are used by engineers and scientists in industry, government and education.

The MPLAB IDE is a free, feature-rich, integrated toolset for the development of embedded applications employing Microchip's PIC® microcontrollers and dsPIC® digital signal controllers. The MPLAB IDE runs as a 32-bit application on the Microsoft Windows® operation system, is easy to use, and includes a host of free software components for fast application development and super-charged debugging. The MPLAB IDE also serves as a single, unified graphical user interface for additional Microchip and third party software and hardware development tools. MATLAB and Simulink plug-ins debut in the current version of the MPLAB IDE, version 7.51, and enables designers to select Simulink software models, automatically generate source code, and include the files in MPLAB IDE projects for compilation and build, all within the familiar, easy-to-use MPLAB IDE graphical user interface.

"The integration between MATLAB, Simulink and the MPLAB IDE will dramatically increase the productivity of production organizations using Model-Based Design with Microchip's hardware," said Tom Erkinen, Embedded Applications manager of The MathWorks, Inc. "With push-button automation, engineers can now generate code from their executable specification models, compile it and download the code to their embedded processor for on-target rapid prototyping or production deployment."

"Wielding the power of MATLAB and Simulink from the MPLAB IDE desktop further empowers the designer of embedded designs using Microchip devices," said Derek Carlson, vice president of Microchip Development Tools. "This collaboration is a significant addition to our tool suite for Microchip's 16-bit microcontrollers, and sets the stage for future cooperative efforts."

## Learn about MPLAB IDE with Online Seminars!

See the Microchip Web Seminars for up-to-date information on using Microchip products. The archive section contains the Introduction to MPLAB IDE Web Seminar for a tutorial that will get you started quickly with MPLAB projects. A seminar entitled Tips and Tricks in MPLAB IDE identifies many of the latest features to make code development even easier. The Visual Device Initializer is demonstrated in a VDI Seminar. There is also an Overview of Microchip Development Tools Seminar, and a walk-through of the powerful features of the simulator and stimulus generator in the MPLAB SIM Seminar. Visit [www.microchip.com/webseminars](http://www.microchip.com/webseminars) for more details.

For additional information, visit at [www.microchip.com/MPLAB](http://www.microchip.com/MPLAB)

[RETURN TO FRONT PAGE](#)

## Looking for an 8-bit MCU that's ideal for low-cost, 3V applications that require flexible serial communication with four serial ports: double synchronous serial ports (I<sup>2</sup>C™ and SPI™) and double asynchronous serial ports?

The PIC18 J-series products are high-performance 8-bit microcontrollers with high levels of integration at 3V for cost-sensitive applications. Microchip has a broad 8-bit microcontroller portfolio that provides solutions for customers demanding high performance and low cost in their general purpose applications with a flexible selection of pin count, program memory and peripherals. Microchip's 3V PIC18 J-series products include the **PIC18F45J10** and **PIC18F87J10** families. The new **PIC18F87J11** family was recently introduced to expand this J-series portfolio. The PIC18F87J11 family includes 64- and 80-pin devices with a robust peripheral set, ranging from 64 to 128 KB Program Flash.

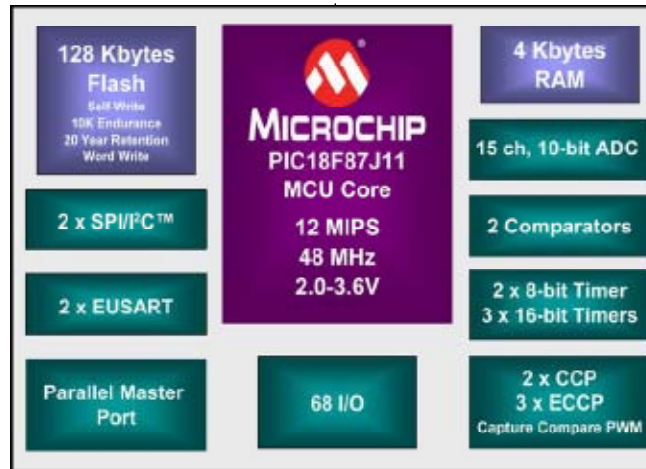

The robust peripheral set on the PIC18F87J11 family includes ADC, capture/compare/PWM, timers, UARTs, I<sup>2</sup>C™ and SPI for communication. The PIC18 J-series microcontrollers open the PIC18 into new cost-competitive markets due to their low prices. It is easy to evaluate the PIC18 J-series devices using the **PICDEM™ HPC Explorer Board**. This low-cost demo board is the ideal complement to the **MPLAB® ICD 2 In Circuit Debugger** to evaluate the performance of Microchip high-end 8-bit microcontrollers of the PIC18F series. The J-series products have plug-in modules that automatically configure the voltage of the PICDEM HPC Explorer Board to be 3V.

The PIC18 J-series has the same basic instruction set and core of the traditional PIC18 5V devices. The operating voltage on the PIC18 J-series is 2.0 to 3.6 which allows you to maximize your performance in a 3 volt application. 3V applications enable cost, performance/speed and run-time power consumption advantages, and still have 5V tolerant digital I/O for easy interface with 5V systems. The PIC18F87J11 devices are capable of 48 MHz and 12 MIPS at 3V, a new benchmark within the PIC18 family.

The PIC18F87J11 offers a direct migration for PIC18F87J10 customers who want additional performance, lower power, higher Flash retention or a parallel master port. Compared to the PIC18F87J10, the PIC18F87J11 provides an enhanced peripheral set and performance including:

- Integrated 8 MHz internal oscillator with 4x PLL for 32 MHz without external clock source
- Lower power in sleep mode for battery applications
- Higher performance: up to 12 MIPS, 48 MHz at 3 volts
- Improved Flash characteristics
  - 10,000 Flash endurance (min)
  - Word-write capability for easier EEPROM emulation
- Parallel Master Port for connection to parallel interfaces such as driving a large display or connecting to a large external data memory

For additional information, visit at [www.microchip.com/PIC18J](http://www.microchip.com/PIC18J)

### Introduction to PIC18 J-series Microcontrollers



Alexis Alcott, Microchip's PIC18 Product Marketing Manager, is pleased to present a new web seminar to get you acquainted with the PIC18 J-series of devices and show how they fit into the rest

of Microchip's product portfolio. The presentation covers the basic features and target applications for the PIC18 J-series products. Information on development tools and additional support for this family is also presented.

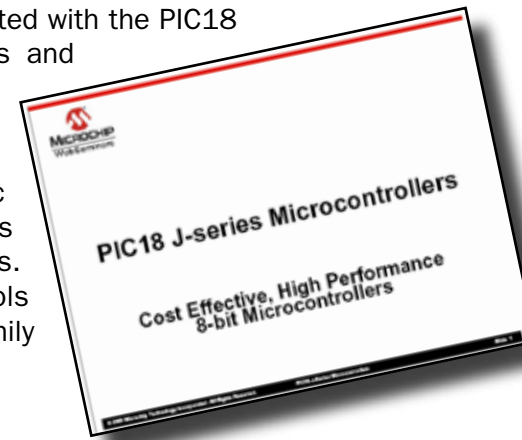

To view this seminar, visit

<http://techtrain.microchip.com/webseminars/ArchivedDetail.aspx?Active=124>

[RETURN TO FRONT PAGE](#)



Join us for training sessions  
at booth 1530!



# Embedded Systems Conference

McEnery Convention Center, San Jose, CA

April 3-5, 2007

**Microchip is excited to be back at ESC this year with a variety of training sessions available daily at the Microchip booth. For a complete class schedule, please visit our web site.**

**Introduction to Digital Power Converter Design Using the dsPIC® Digital Signal Controller Family for SMPS:** This class introduces the design and implementation of a digital mode synchronous buck DC/DC converter using the dsPIC DSC family for SMPS. The SMPS PWM, ADC, and analog comparator modules, combined with the dsPIC DSC processor, enables the creation of power conversion circuits utilizing digital control loops. This class discusses the SMPS peripherals and their use in an actual circuit, along with their integration with the control loop software.

**MPLAB® REAL ICE™ In-Circuit Emulator Demonstration:** This class demonstrates the features and advantages of Microchip's next generation high speed emulation system, the MPLAB REAL ICE. The MPLAB REAL ICE features real-time, full speed emulation and fast programming of Microchip Flash MCU and DSC devices. Real-time variable watch and trace analysis are just two of the many features, all for under \$500.

**LeCroy Solutions for Debugging and Validating USB and Ethernet Designs:** LeCroy oscilloscopes and protocol analyzers enable engineers to design, test and validate high-performance electronic systems faster and more efficiently. This class focuses on LeCroy solutions for debugging and validating USB and Ethernet designs. Come see the equipment utilized by Microchip in its Regional Training Center classes.

**Mechatronics Defined:** As technology advances, designs that were once purely mechanical are now best done with electronics or a combination of both. This class explores what mechatronics is, the role PIC® microcontrollers are playing and the benefits of mechatronic designs versus mechanical designs. Mechatronics is broken down at the system level so that you can study the components necessary for your design.

**ZigBee™ and MiWi™ Protocols:** Discussion of ZigBee™ protocol and Microchip stack capabilities as well as an introduction to Microchip's own wireless MiWi™ protocol. The MiWi protocol is available free of charge and is ideal for users not needing full protocol interoperability.

**Ethernet Solutions from Microchip:** Ethernet's capabilities and ubiquitous deployment make it unrivaled among communications standards. This class presents Microchip's cost-effective and easy-to-use Ethernet products, software and development tools including our 28-pin stand-alone Ethernet controller, our family of PIC18F microcontrollers with Ethernet peripheral and free TCP/IP stack. Learn how to add Ethernet capability to your embedded design.

**16-bit Microcontroller and Digital Signal Controller Product Family Overview:** If you're an embedded designer looking for high-performance products coupled with a solid migration strategy, this class shows you the benefits of using one software development environment to program everything from your simplest 6-pin, 8-bit microcontroller to the industry's highest performing 16-bit microcontrollers and digital signal controllers. Technical experts will showcase the architectural and peripheral features of Microchip's new 16-bit microcontroller and digital signal controller families.

**Analog Sensor Conditioning in Embedded Systems:** Most sensor circuits require some analog signal conditioning before conversion to digital. This class provides background information on several types of sensors and sensor conditioning circuits, including active filters. Three common sensors, thermistor (temperature), photodiode (light) and capacitance (humidity) and their conditioning circuits, are detailed. A demonstration of filter designs generated by Microchip's FilterLab® software is included.

To register for our training sessions, please visit [www.microchip.com/ESC](http://www.microchip.com/ESC)

[RETURN TO FRONT PAGE](#)

## Are you looking for ways to reduce costs in order to extend a product's life span?

### Check out the newest member of the general-purpose, small PIC® microcontroller family!

The new **PIC16F882** is the lowest-cost member of Microchip's 28- and 40/44-pin **PIC18F88X** family of microcontrollers, for use in a wide range of applications. The PIC16F882 gives you the option to migrate to a lower-cost family member, as your code development stabilizes. All five members of the PIC16F88X family maintain compatibility with other 28/40-pin PIC microcontrollers for easy migration, while providing a host of new features designed to save you time and money – both during and after your design cycle. The enhancements include dual internal oscillators with clock switching and fail-safe clock mode; more (up to 14) ADC channels; an advanced comparator module featuring two comparators and a Set/Reset Latch to allow emulation of many analog circuits; and low-power enhancements that extend battery life.

**Do you look for ways to reduce costs in order to extend a product's life span during the later stages of your product cycles?** The PIC16F88X family provides a consistent peripheral set and multiple memory-size options – so making a change is simple and requires minimal migration effort. This family is complemented by a vast portfolio of pin- and code-compatible PIC microcontrollers that help you migrate to the right part for your chosen application, without having to write all new code.

Specific application examples for the PIC16F88X family include battery-operated systems and battery management, space-constrained and small form factor applications, analog-intensive applications (due to the rich on-chip analog peripheral set), and mechatronics.

The five-member PIC16F88X family is supported by the full suite of Microchip's development tools, including the **PICKit™ 2 Development Programmer** (PG164120), \$34.99, the free **MPLAB® IDE Integrated Development Environment** and the low-cost **MPLAB ICD 2 In-circuit Debugger**. Additionally, a processor module for the **MPLAB ICE 2000 In-circuit Emulator** is expected to be available this month.

The **PIC16F883**, **PIC16F884**, **PIC16F886** and **PIC16F887** microcontrollers are in production now and are available for general sampling and volume production shipments. Production volumes of the PIC16F882 microcontroller are expected to be available in April. The PIC16F882, PIC16F883 and PIC16F886 come in 28-pin PDIP, SOIC, SSOP and QFN packages, while the PIC16F884 and PIC16F887 are available in 40-pin PDIP, and 44-pin QFN and TQFP package options.

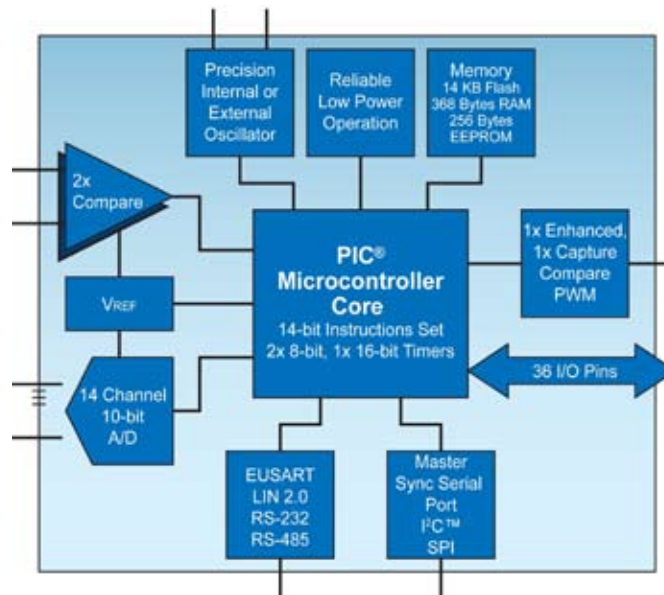

### PIC16F882 Features:

- 3.5 Kbytes of self-write program Flash memory and low-voltage programming to enable field programmability
- 128 bytes of data EEPROM for variable data storage
- On-board in-circuit debug module for simpler system troubleshooting
- Advanced Analog Peripherals
  - Enhanced analog comparator module, featuring 2 comparators with Set/Reset Latch mode
  - 11 10-bit ADC channels
  - 0.6V reference voltage for comparators and ADC
- Low-power features
  - Ultra low-power wake up
  - Enhanced low-current Watchdog Timer
  - Low-Power Timer 1 oscillator
- Serial communication interfaces
  - UART/SCI connectivity via EUSART module
  - Master Mode SPI and I²C™ with address mask option
- More general purpose I/O, with up to 36 pins that can be used for I/O, and Interrupt-on-change capability for each I/O pin
- Available in industrial and automotive temperature versions

For additional information, visit at [www.microchip.com/PIC16F88X](http://www.microchip.com/PIC16F88X)

[RETURN TO FRONT PAGE](#)

# Bit Bashing; The practice of combining peripherals, external components and firmware to create a new function, feature or peripheral (slang)

In model aircraft parlance, kit bashing is defined as the practice of using the materials from a kit for one aircraft to build a similar, but different, aircraft. So, bit bashing is the process of using the features of one or more simple peripherals to build a more complex custom peripheral.

## This month's Bit Bash:

**When cost is an issue  
And you have to run from the line -  
Transformerless is the option,  
But can I save any more with the  
high-voltage MCU line?**

Written by: Keith Curtis, Principal Applications Engineer

It is one of the true ironies in electronic design, that powering low-power MCUs directly from the AC lines is one of the most problematic circuits to design. You have an MCU that draws almost no power, connected to basically an infinite power source, but translating the high-voltage AC to the low-voltage DC is annoyingly difficult to do in a cost-effective manner.

Traditionally, line-powered, low-current applications use a resistive transformerless design, such as the circuits shown in Figure 1. Basically, when the line is higher in voltage than the neutral, the zener diode reverse biases at its rated zener voltage, and capacitor C1 is charged through D2. When the neutral is higher, the zener diode forward biases, D2 reverse biases, and the C1 is isolated. Pretty simple, R1 and R2 current limit the zener diode, and D2 isolates C1 during the off half of the cycle. However, the implementation of this simple circuit is where the problems creep in.

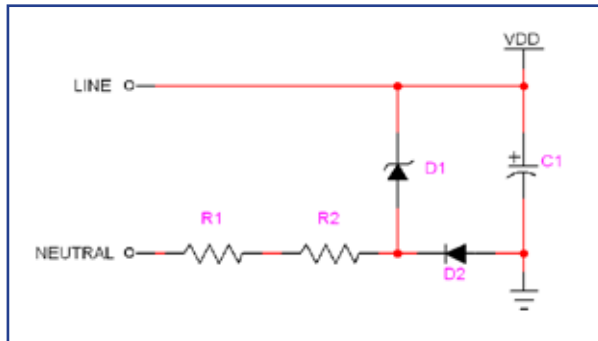
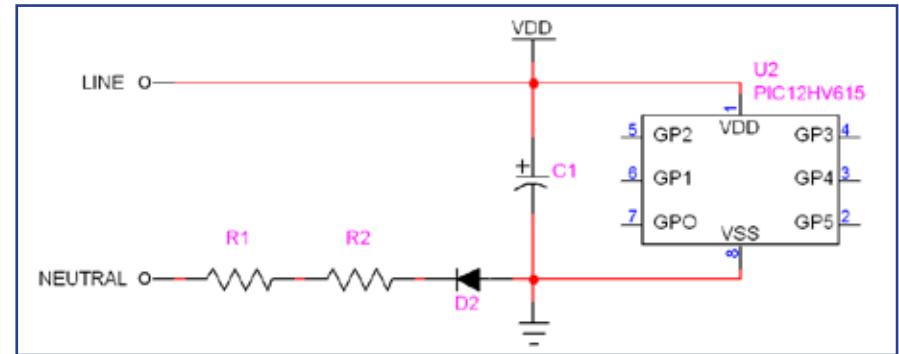

Figure 1 Typical Transformerless Power Supply Design

To begin, the charge on C1 must be sufficient to power the MCU through the off half of the cycle, while D2 is reverse biased. This means that R1 and R2 must pass twice as much current to charge C1 during the first half of the cycle. And during the second half of the cycle, they also have to pass this same current again when the zener diode is forward biased. So, R1 and R2 end up dissipating at least 100 mW a piece, for every 1 mA of supply current. And that does not include the bias current

to keep the zener at voltage, so call it 150 mW per resistor, per mA of supply current.

How does a high-voltage MCU help me in this system? Doesn't it draw a minimum of 4 mA of supply current just to stay in regulation? Every mA of current means another 150 mW of power in R1 and R2. True, the shunt regulator requires 4 mA of current to stay in regulation. However, using the circuit below, R1 and R2 only dissipate power during half of the AC cycle, as the rectifier diode D2 prevents current flow on the second half of the cycle – cutting the power dissipation of R1 and R2 in half.



When the charge in C1 drops VDD below 4.7V, the shunt regulator shuts down and draws less than 120 mA. This means that the shunt regulator only draws current when C1 is being charged, not during the rest of the cycle – the power dissipation through R1 and R2 is only an issue when the supply voltage is greater than 4.7V. Once the current flow through R1 and R2 drops below 4 mA, the shunt regulator will draw current from C1, assisting in the rapid drop of the supply voltage to the 4.7V shutdown.

The secret to using the shunt regulator in line-powered applications is to limit the percentage of the half cycle during which the resistors hold VDD above 4.7V. This is done by keeping R1 and R2 as large as possible, and keeping C1 to the minimum possible value, so it will drop quickly once the current from the resistors drops off. The power rating of the resistors is determined by integrating the power dissipation in the resistors over the period of the waveform during which the regulator is in regulation, and dividing by the full AC waveform cycle.

One final note on the use of the shunt regulator, the VDD supply voltage will only be regulated during the peak of the one half cycle of the AC waveform. As a result, ADC and comparator measurements that rely on regulation of the VDD rail should only be performed during the peak of the charging half cycle. High current outputs should also be kept short, and preferably performed during the peak of the charging half cycle, and not during an ADC conversion to prevent unregulated operation due to current starving the regulator.

[RETURN TO FRONT PAGE](#)

# Communication is Vital



*In the Wiley book “Driving Excellence”, Chapter 17, we describe “Human Systems” and “Communication” as the back bones of the company culture. The CEO’s quarterly employee communication meeting is the single most powerful vehicle for instilling and maintaining the company’s culture. This meeting, which takes place at the end of each quarter, allows employees to hear how the company is doing directly from the top. In addition, time is set aside for employees to ask questions, and they can see whether the CEO practices the company culture. Typically, this meeting focuses on how the company is performing overall,*

*market conditions, quarterly P&L results, stock performance, major initiatives, and current challenges. Moreover, during such meetings, variable compensation payouts, such as company-wide employee bonuses, are discussed. If the company experiences a difficult period, such meetings are effective forums to discuss the situation. This may scare some CEOs, but having done it on several occasions, I can testify to its advantages. If the CEO is open and forthright, employees love these meetings.*

The meetings also reinforce that communication is valued. You’ll often hear employees say after these meetings, “With his hectic schedule, isn’t it great that the CEO takes the time to communicate with us directly?” This is the CEO’s time to reach the people and inspire them to achieve future goals, or to prepare them to begin adapting to difficult business conditions. It may be impractical for the CEO to talk to all employees face to face. Therefore, technology may be needed to conduct the meeting. For example, the CEO can give a live meeting to a large group of employees at one site and then video- or phone-conference the other sites.

Many CEOs will initiate these meetings with a sincere desire to improve communication. However, due to the demand placed on the CEO, often these types of meetings will get postponed and somehow never get rescheduled. Soon, other pressing problems come up. Then, the business environment may change and the CEO will no longer clearly know whether the following quarter will be a good one or the start of a downturn. The CEO then avoids facing the employees and cancels

another quarterly employee communication meeting. By now, nine months may have gone by and regular communication meetings have become a thing of the past.

Conducting regular quarterly employee communication meetings requires a true and honest commitment from the CEO. At Microchip, I have not missed a quarterly communication meeting with the employees in 66 straight quarters (since July of 1990). I have always felt that during times of transition, it is even more important to have communication meetings with employees. In January 2005, it was not clear which way the semiconductor industry was headed. Some Wall Street analysts believed that the industry was headed downward. Others felt that it would be a short-lived inventory correction. In my January 2005 communication meeting with employees, I discussed this situation in detail. I discussed my position, opposing views concerning the future market conditions, a series of “what if” scenarios, and Microchip’s strategy and back-up plans. I left employees with specific instructions to be frugal and cut back on discretionary expenses. I also laid out a plan for future growth irrespective of the short-term direction of the industry.

The response from the employees was overwhelmingly positive. Here are two E-mails from employees that typify the employees’ appreciation with my open and honest communication:

Mr. Sanghi,  
I just thought you would like to know that today’s quarterly communication meeting was more educational than any business class I have ever attended... Thank you.

Regards,  
Jeff

Steve,  
I wanted to provide you with some positive feedback that I have received from the Production Specialists on our most recent quarterly communications meeting. The people were extremely pleased with your honesty. They felt you provided them with clear cut information on where we stand as a company, while still preparing them for any negative actions that could come up. They felt you showed that you gave thoughtful consideration for the employees and company as a whole. Many of the people strongly agreed with your accuracy about our trends, directions, and the good judgment you have delivered over the years. I believe you made an excellent impression on the employees and have effectively gained their support with your current decision.

Thank you,  
Sheila

*Continued on next page...*

[RETURN TO FRONT PAGE](#)

Continued from previous page...

Microchip and the entire semiconductor industry are currently going through another inventory correction. Microchip's December 2006 quarter was sequentially down in revenue and profits. I again conducted a scheduled communication meeting in January 2007 and discussed the situation in detail. Microchip's financial guidance this quarter is flat to December 2006, while all the rest of the semiconductor industry is guiding down significantly. I discussed this out-performance by Microchip, its potential reasons, risks and uncertainties. And then I discussed our strategy and back up plans. I left employees with specific instructions to be frugal and cut back on discretionary expenses.



Time will tell if I'm correct again this time. But, the employees are all aligned to our strategy and pulling in the same direction. That is why the CEO's quarterly communication meeting is the single most powerful vehicle for instilling and maintaining the company culture.

– Steve Sanghi, President and CEO of Microchip Technology Inc.

For more information on Microchip's culture, visit [www.DrivingExcellence.Biz](http://www.DrivingExcellence.Biz)

**RSS**  
Subscribe today!

Really Simple Syndication (RSS) is a standard content format that allows syndication of information across the web. RSS allows you to view important content in a central location and allows us to distribute Microchip content in a standard (XML) format directly to you.

Our Microchip RSS feeds are free and allow you to receive continual headlines and updates in a convenient

format without accessing many different web sites directly. They deliver important Microchip content, with links back to [www.microchip.com](http://www.microchip.com) for the full text. It allows you to pull our content into the same format as other RSS feeds you may already subscribe to.

The **RSS** icons on our site are links to RSS feeds that you can subscribe to via your RSS reader. [Click here](#) to view our 'How To Use RSS' page.

## Check Out Our New MCP3909 Energy-measurement IC and Reference Design!

The **MCP3909** is a highly accurate IC that combines low power consumption with an SPI interface and active power-pulse output, making it adaptable to a wide variety of meter designs. Together with the **MCP3909 3-Phase Energy Meter Reference Design** (Part # MCP3909RD-3PH1), the IC enables you to develop and bring meter designs to market quickly.

The MCP3909 IC has two 16-bit delta-sigma ADCs onboard that can be accessed through its SPI interface, while simultaneously providing a pulse output with a frequency proportional to the active-power calculation. This simultaneous output of data makes the IC flexible and easy to use, as well as adaptable to a variety of meter requirements. Additionally, with its very low, 0.1% typical measurement error over a 1000:1 dynamic range, the MCP3909 IC easily fits into meter applications requiring high accuracy. Its extremely low supply current of only 4 mA makes it suitable for many single- and three-phase energy meter designs, and helps customers remain within their power budget.

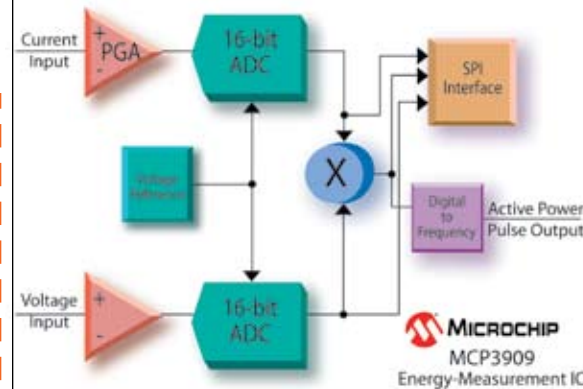

*"With its high levels of integration and accuracy, the MCP3909 is a user-friendly energy measurement IC that can be easily applied to a variety of single- and three-phase metering applications. Together with the MCP3909 3-phase Energy Meter Reference Design, users can quickly get started on metering designs using PIC® microcontrollers."*

– Bryan Liddiard, vice president of marketing, Microchip's Analog and Interface Products Division

The MCP3909 3-Phase Energy Meter Reference Design (Part # MCP3909RD-3PH1) includes three MCP3909 ICs, plus a PIC18F2520 and a PIC18F4550 microcontroller. The PIC18F2520 performs all power calculations in the reference design, while the PIC18F4550 provides a USB interface to desktop software. The software package that comes with the reference design enables meter calibration and the ability to read active and apparent power, as well as RMS current and RMS voltage.

For additional information, visit at [www.microchip.com/MCP3909](http://www.microchip.com/MCP3909).

[RETURN TO FRONT PAGE](#)

# Looking for the world's largest inventory of Microchip products?



Come to microchipDIRECT and see what we can do for you today!

## How much are you paying to program your PIC® microcontroller?

	Example Device	Package Type	Quantity Programmed	microchipDIRECT Programming Charge
Sample Pricing	PIC10F202-I/OT	6-Lead SOT-23	5001+	\$0.02 each
	PIC16F630-E/SL	14-Lead SOIC	5001+	\$0.08 each
	PIC16F627A-I/SS	20-Lead SSOP	5001+	\$0.10 each
	PIC16F57-I/SP	28-Lead PDIP	5001+	\$0.12 each
	PIC18F4520-I/ML	44-Lead QFN	5001+	\$0.20 each
	PIC18F8722-I/PT	80-Lead TQFP	5001+	\$0.23 each

**microchip**  
**DIRECT**  
www.microchipdirect.com

Your most comprehensive resource for Microchip products.

## Did you know that you can now download development software from microchipDIRECT?

microchipDIRECT now provides a “software for sale” download capability. You can purchase Microchip’s embedded-development software quickly and easily from [www.microchipdirect.com](http://www.microchipdirect.com). The first Microchip products being offered through this service are the popular **MPLAB® C18** and **MPLAB C30 C Compilers**. These compilers are full-featured and ANSI compliant, and download with extensive libraries

**With no shipping costs involved, downloading software from microchipDIRECT can also be a convenient way to save money on your tool kit.**

for embedded-development applications using Microchip’s **PIC18** high-end 8-bit and **PIC24** 16-bit families of microcontrollers, as well as the dsPIC® digital signal controllers. More software products are expected to be added in the future. Microchip also intends to work with third-party software vendors to offer their software tools and libraries for download on microchipDIRECT.

MPLAB C18 and MPLAB C30 C compilers are fully integrated with Microchip’s free **MPLAB Integrated Development Environment (IDE)**. Both compilers generate relocatable object modules, which can be

linked with assembly modules or in-line assembly code to generate reusable code modules for any embedded application. The MPLAB IDE provides a comprehensive graphical front end to leverage code development with the MPLAB C18 and MPLAB C30 compilers via a project manager, a programmer’s text editor and a rich suite of robust debugging tools. Extensive multi-pass optimizations generate compact, robust code that can be directly downloaded to Microchip’s microcontrollers using Microchip’s programmers, in-circuit debuggers and in-circuit emulators. Both compilers generate re-entrant code and support third-party tools, such as Real-Time Operating Systems (RTOSs) and application-specific libraries.

A free Student Edition of each compiler is also available for evaluation download from the Microchip web site at [www.microchip.com/c30](http://www.microchip.com/c30) and [www.microchip.com/c18](http://www.microchip.com/c18), respectively.

For additional information, visit at [www.microchipDIRECT.com](http://www.microchipDIRECT.com)

[RETURN TO FRONT PAGE](#)

# Microchip Around Town

**Embedded Systems Conference**  
Silicon Valley

**Join Microchip in the following technical sessions at ESC!**



McEnery Convention Center  
San Jose, CA

## **Managing Power, Ground, Noise in Microcontroller/Analog Applications**

Thursday (April 5, 2007) 2:00pm – 3:30pm

Salon 1 & 2/Marriott

<https://www.cmpevents.com/ESCw07/a.asp?option=C&V=11&SessID=4377>

Join Microchip's Keith Curtis and learn guidelines for sign, component selection and PWB layout for combining fast logic, power and sensitive analog in a common design. Microcontroller applications often have low-level sensor signals and moderate power-drive circuitry. Peaceful coexistence among these three extremes requires a careful power and ground distribution design. This paper will discuss sources of noise and the paths by which it travels, the theory behind good layout practices and their impact on noise and the proper selection and placement of noise-isolating and limiting components. Designers wanting to keep digital and power noise out of sensitive input circuits will find this paper useful.

## **Designing Embedded Systems that Use Shared Modules**

Thursday (April 5, 2007) 11:00am – 12:30pm

Almaden Ballroom 2/Hilton

<https://www.cmpevents.com/ESCw07/a.asp?option=C&V=11&SessID=4363>

Microchip's Senior Embedded Software Engineer, Sean Justice, will show you how to identify, place and use shared modules in a multi-application embedded system. Many embedded systems have multiple applications, such as a system that contains a boot loader to place itself in a known safe state, while at the same time uploading the system's main application. This paper will discuss how multi-application embedded systems can utilize shared modules to decrease the amount of system resources used. How to identify shareable modules and where to place them will be discussed, as well as how to make shared modules accessible by all applications.

## **High-Quality Speech Compression Without Royalties**

Thursday (April 5, 2007) 11:00am – 12:30pm

Salon 1 & 2/Marriott

<https://www.cmpevents.com/ESCw07/a.asp?option=C&V=11&SessID=4354>

Priyabrata Sinha, Senior Applications Engineer at Microchip, will help you gain familiarity with some key royalty-free speech compression techniques that are suitable for implementation on low-cost embedded systems such as Digital Signal Controllers (DSCs). His paper describes an inexpensive speech compression technique using the open-source "Speex" algorithm, based on a variant of the Codebook Excited Linear Prediction (CELP) compression technique. The paper will discuss A-law and  $\mu$ -law commanding as specified by the ITU G.711 standard and ADPCM-based compression based on the ITU G.726A standard. Design examples showing implementation of these techniques using dsPIC<sup>®</sup> digital signal controllers will be presented, and an overview of applications requiring speech compression and decompression will be provided.

**Microchip is also participating in the following events:**

**BATTERY POWER 2007** June 6-7  
Denver, Colo.

## **Battery Power 2007**

June 6 – 7, 2007 • Denver, CO

[http://www.batterypoweronline.com/bp07\\_program.htm](http://www.batterypoweronline.com/bp07_program.htm)

Keith Curtis presents "Super Capacitors – The Next Rechargeable Battery?" This presentation explains the use of super capacitors as an energy-storage medium, with a solar-based emergency power reference design as an example. The goal of the system is to provide continuous power to the emergency system during both day and night hours. The design will show how super-capacitor-based storage will be tasked with automatically charging when energy is available, providing power when energy is not available from the solar panels and providing short-term, panel support in times of high current draw.

Microchip will host a half-day pre-conference workshop on June 5, 2007. Terry Cleveland, Staff Engineer for Microchip's Analog & Interface Products Division is scheduled to present a four-hour seminar that explains the development of linear- and switching-charger designs.



## **2007 American Society for Engineering Education (ASEE) Annual Conference & Exposition**

June 24 – 26, 2007 • Honolulu, HI

<http://www.asee.org/conferences/annual/2007/index.cfm>

John Magrane and Professor Lakshmi Munukutla from Arizona State University are scheduled to present a paper that demonstrates how industry and academia can develop programs to assist universities in attracting students and ensure a pipeline of highly skilled business-ready graduates. Not only will these programs help academia and industry, but also provide students with a superior education and improved employment prospects.

Principal Application Engineer Keith Curtis is scheduled to present "Embedded Software Design Methodology to Help Students Succeed in the Real World," and Microchip's Carol Popovich will co-present a paper with Professor Lakshmi Munukutla of ASU entitled "Universities and Industry Can Partner to Create Engineering Entrepreneurs."

[RETURN TO FRONT PAGE](#)

# WHAT'S *New* IN MICROCHIP LITERATURE?

Visit our **Technical Documentation** page on [www.microchip.com](http://www.microchip.com) to view the documents.

Doc. Type	DS No.	Doc. Title	Printed/ Web
<b>App Note</b>	00965C	AN965, Microchip Stack for the ZigBee Protocol	web
	01024B	PKE System Design Using the PIC16F639	web
	01066A	AN1066, MiWi Wireless Networking Protocol Stack	web
	01070A	PIC16F913/914/916/917/946 Driving Liquid Crystal Displays	web
	01073A	Interfacing P89LPC9X to 25XXX Serial EEPROMs	web
	01074A	PIC12HV615 Software PWM Generation for LED Dimming and RGB Color Applications	web
<b>Data Sheet</b>	21713H	24AA32A/24LC32A Data Sheet	web
	39755A	PIC18F87J50 Data Sheet	web
	39778B	PIC18F87J11 Family Data Sheet	web
	41206B	PIC16F716 8-Bit Data Sheet	web
	41262D	PIC16F6XX/690 Data Sheet	web
	41270D	PIC10F220/222 Data Sheet	web
	70282A	PIC24HJ12GP201/202 Data Sheet	web
<b>Errata</b>	80151M	PIC16F627A/628A/648A Rev. A Silicon Data Sheet Errata	web
	80190E	PIC12F508/509 Rev. A Silicon Data Sheet Errata	web
	80292B	PIC18F97J60 Family Rev. A0 Silicon Errata	web
	80202E	PIC18F2585/2680/4585/4680 Rev. A1 Silicon Errata	web
	80206E	PIC18F6310/6410/8310/8410 Rev. B3 Silicon Errata	web
	80207E	PIC18F6390/6490/8390/8490 Rev. B3 Silicon Errata	web
	80219C	PIC18F2480/2580/4480/4580 Rev. A1 Silicon Errata	web
	80224D	PIC18F2525/2620/4525/4620 Rev. A4 Silicon Errata	web
	80238B	PIC16F91X Rev. A Silicon Data Sheet Errata	web
	80283C	PIC18F2585/2680/4585/4680 Rev. A3 Silicon Errata	web
	80284C	PIC18F2682/2685/4682/4685 Rev. A1 Silicon Errata	web
	80303A	dsPIC30F6011A/6012A/6013A/6014A Rev. B0 Silicon Errata	web
	80304A	PIC18F2420/2520/4420/4520 Rev. B3 Silicon Errata	web
	80305A	PIC18F87J11 Family Rev. A1 Silicon Errata	web
<b>Migration Guideline</b>	41310A	PIC18F4520 to PIC18F45K20 Migration	web
<b>Programming Spec</b>	41196F	PIC16F627A/628A/648A EEPROM Memory Programming	web
	41297B	PIC18F2XK20/4XK20 Programming	web
	70284A	dsPIC30F SMPS Flash Programming Specification	web

Doc. Type	DS No.	Doc. Title	Printed/ Web
<b>Family Reference Manual (FRM) Chapter</b>	DS70267A	dsPIC30F FRM - Section 28. Interrupts (Part 2)	web
	DS70268A	dsPIC30F FRM - Section 29. Oscillator (Part 2)	web
	DS70270B	dsPIC30F FRM - Section 30. Power Supply PWM	web
	DS70266A	dsPIC30F FRM - Section 31. SMPS ADC	web
	DS70269B	dsPIC30F FRM - Section 32. Analog Comparator	web
	DS70228A	PIC24H FRM - Section 5. Flash Programming	web
	DS70224A	PIC24H FRM - Section 6. Interrupts	web
	DS70227A	PIC24H FRM - Section 7. Oscillators	web
	DS70229A	PIC24H FRM - Section 8. Reset	web
	DS70230A	PIC24H FRM - Section 10. I/O Ports	web
	DS70225A	PIC24H FRM - Section 16. Analog-to-Digital Converter (ADC)	web
	DS70232A	PIC24H FRM - Section 17. UART	web
	DS70226A	PIC24H FRM - Section 21. Enhanced Controller Area Network (ECAN)	web
	DS70231A	PIC24H FRM - Section 25. Device Configuration	web
	DS70233A	PIC24H FRM - Section 29. Interrupts (Part 2)	web
	DS70234A	PIC24H FRM - Section 30. I/O Ports w/ Peripheral Pin Select	web
	DS70191B	dsPIC33F FRM - Section 5. Flash Programming	web
	DS70192B	dsPIC33F FRM - Section 8. Reset	web
	DS70193B	dsPIC33F FRM - Section 10. I/O Ports	web
	DS70188B	dsPIC33F FRM - Section 17. UART	web
DS70194B	dsPIC33F FRM - Section 25. Device Configuration	web	



[Request Additional Literature](#)



[Data Sheet Finder](#)



[Product Selector Guide](#)

[RETURN TO FRONT PAGE](#)

web site  
HIGHLIGHTS

# MICROCHIP MAPS



Microchip Advanced Parts Selector

## What is MAPS? Why use it?

The new Microchip Advanced Product Selector (MAPS) Version 2.0 has debuted online, providing a comprehensive selection tool for Microchip's complete product portfolio including analog, memory, microcontrollers and digital signal controllers. MAPS is available at the Microchip web site and can be downloaded in electronic form.

MAPS makes it even easier to find the right Microchip product for your design requirements. This online database incorporates an interactive GUI, allowing online parametric searches and easy navigation through Microchip's product portfolio with the use of tabs, filters and search features.

The tool provides side-by-side comparison of products as well.

It also provides invaluable cross references to competitive information and pricing on designated product families – with the ability to obtain the most up-to-date collateral and information with online access.

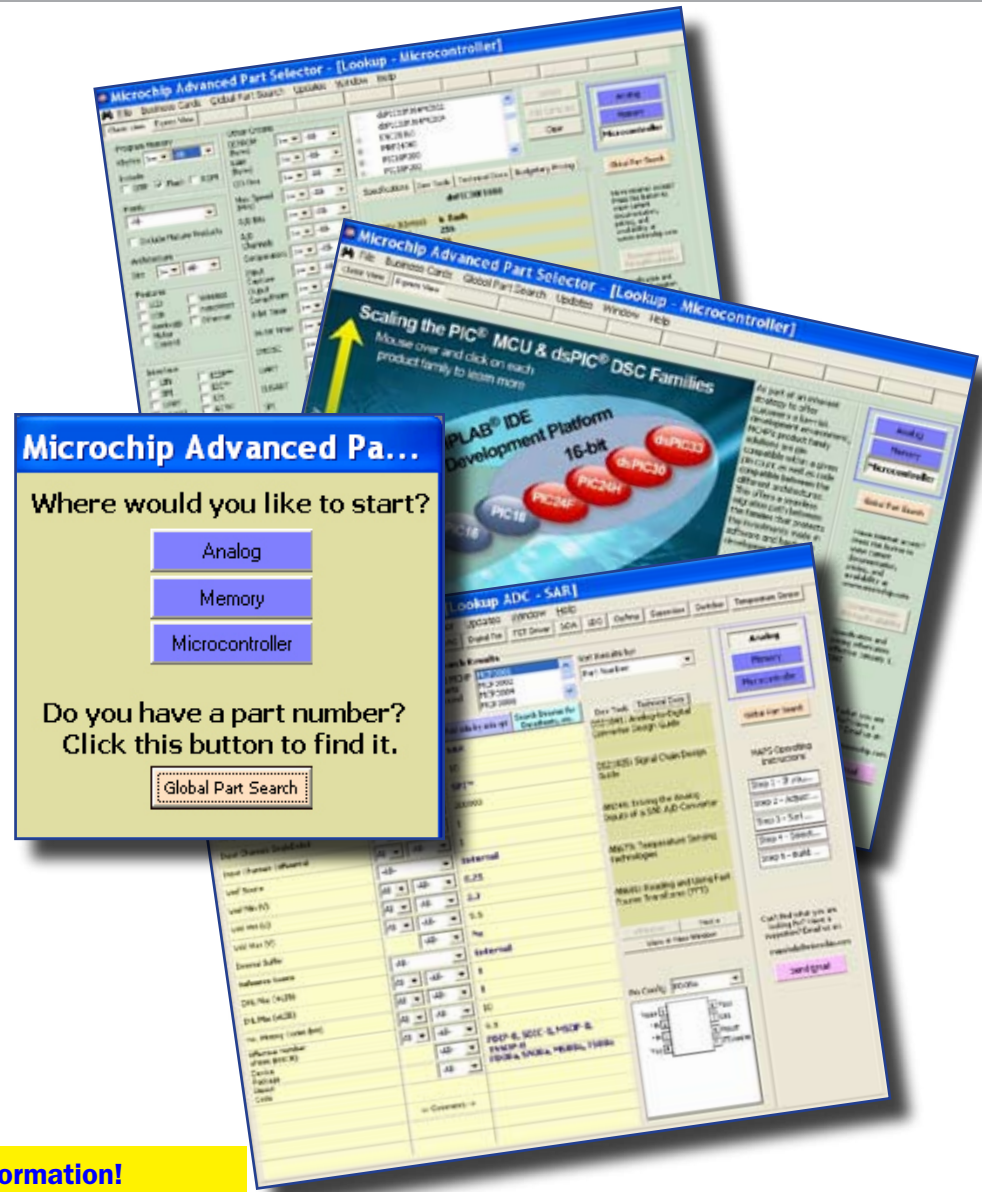

Visit the MAPS web site at [www.microchip.com/MAPS](http://www.microchip.com/MAPS) for more information!



The Microchip name and logo, the Microchip logo, Accuron, dsPIC, KeLo, microID, MPLAB, PIC, PICmicro, PICSTART, PRO MATE, PowerSmart, rPIC and SmartShunt are registered trademarks of Microchip Technology Incorporated in the U.S.A. and other countries. AmLab, FilterLab, Migratable Memory, MXDEV, MXLAB, SEEVAL, SmartSensor and The Embedded Control Solutions Company are registered trademarks of Microchip Technology Incorporated in the U.S.A. Analog-for-the-Digital Age, Application Maestro, CodeGuard, dsPICDEM, dsPICDEM.net, dsPICworks, ECAN, ECONOMONITOR, FanSense, FlexROM, fuzzyLAB, In-Circuit Serial Programming, ICSP ICEPIC, Linear Active Thermistor, MINDI, MiWi, MPASM, MPLIB, MPLINK, PICKIT, PICDEM, PICDEM.net, PICLAB, PICtail, PowerCal, PowerInfo, PowerMate, PowerTool, REAL ICE, rLAB, rPICDEM, Select Mode, Smart Serial, SmartTel, Total Endurance, UNI/O, WiperLock and ZENA are trademarks of Microchip Technology Incorporated in the U.S.A. and other countries. SQTP is a service mark of Microchip Technology Incorporated in the U.S.A. All other trademarks mentioned herein are property of their respective companies. ©2007, Microchip Technology Inc.

[RETURN TO FRONT PAGE](#)