



MIC22205 Evaluation Board

2A Integrated Switch High-Efficiency Synchronous Buck Regulator

General Description

The Micrel MIC22205 is a high-efficiency, 2A, integrated switch, synchronous buck (step-down) regulator. It is frequency programmable up to 4MHz. The MIC22205 achieves more than 95% efficiency and switches at 1MHz. The ultra-high-speed control loop keeps the output voltage within regulation even under the extreme transient load swings commonly found in FPGAs and low-voltage ASICs. The output voltage is pre-bias safe and is adjustable down to 0.7V.

The MIC22205 offers a full range of sequencing and tracking options. The Enable/Delay (EN/DLY) and Power Good (PG) inputs allow versatile turn-on and turn-off sequencing across multiple devices. The Ramp Control™ (RC) input allows start-up voltage tracking, either directly or ratio-metrically.

The MIC22205 is available in a 12-pin 3mm x 3mm MLF® with a junction operating range from -40°C to +125°C.

Data sheets and support documentation are available on the Micrel web site: www.micrel.com.

Requirements

The MIC22205YML EV requires a power supply of 2.9V to 5.5V, and a test load. Make sure that the power supply can provide the wattage needed for the chosen test load. The load can be active (electronic load) or passive (resistor). Additionally, monitor the Power Good output (PG) with a multimeter or an oscilloscope.

Precautions

There is no reverse input protection on this board. While connecting supplies and signals, make sure that correct polarities are observed.

Getting Started

1. V_{IN} Supplies

Connect the V_{IN} supply (2.9V to 5.5V) across the VIN and PGND terminals. Monitor V_{IN} at the VIN and PGND terminals with a voltmeter. TP9 is a 4-pin header test point provided for monitoring VIN.

2. Enable

The enable input EN is internally pulled up with a 1 μ A current source.

3. Monitor Outputs

Monitor the output V_{OUT} with a scope or DVM connected across the VOUT and PGND terminals. TP11 is a 4-pin header test point provided for monitoring VOUT.

4. Output Load

Connect a load across the VOUT and PGND terminals. Use an active or passive load.

5. Turn On the Power

Turn on the power supply and verify that $V_{OUT} = 1.8V$.

Ordering Information

Part Number	Description
MIC22205YML EV	Evaluation Board for the MIC22205YML

Ramp Control is a trademark of Micrel, Inc.

MLF and *MicroLeadFrame* are registered trademarks of Amkor Technology, Inc.

Micrel Inc. • 2180 Fortune Drive • San Jose, CA 95131 • USA • tel +1 (408) 944-0800 • fax + 1 (408) 474-1000 • <http://www.micrel.com>

Evaluation Board Features

See the *MIC22205YML Data Sheet* for detailed explanations of these functions.

Enable/Delay (EN/DLY)

Enable/Delay allows delayed turn-on of the MIC22205. Install a capacitor in location C7 to increase the start-up delay of the MIC22205.

$$t_{\text{EN/DLY}} = \frac{1.24 \times C_7}{1 \times 10^{-6}}$$

Ramp Control (RC)

Ramp control allows slowing the slew rate of the MIC22205 output. Increase the value of capacitor C6 to reduce the slew rate.

$$t_{\text{RAMP}} = \frac{0.7 \times C_6}{1 \times 10^{-6}}$$

Power On Reset Output (POR)

Open drain output POR pulls low when the output voltage of the MIC22205 is out of specification. POR is pulled up to V_{IN} by a 47.5k Ω resistor.

Switch Voltage (V_{SW})

Test point V_{SW} is provided to monitor the internal switching node. V_{SW} is isolated from the switch node by 49.9 Ω resistor R7. TP10 is a 2-pin header test point provided for monitoring switch voltage.

Typical Characteristics

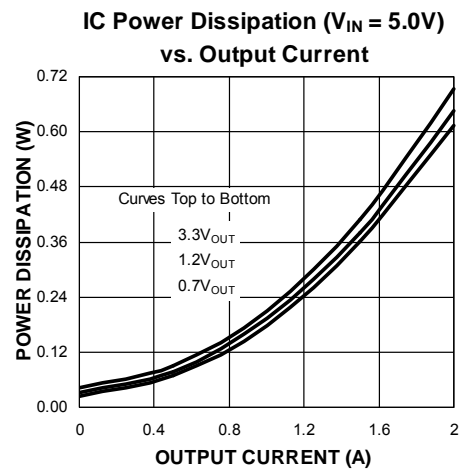
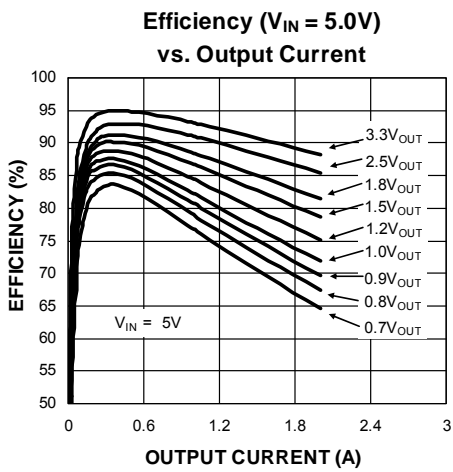
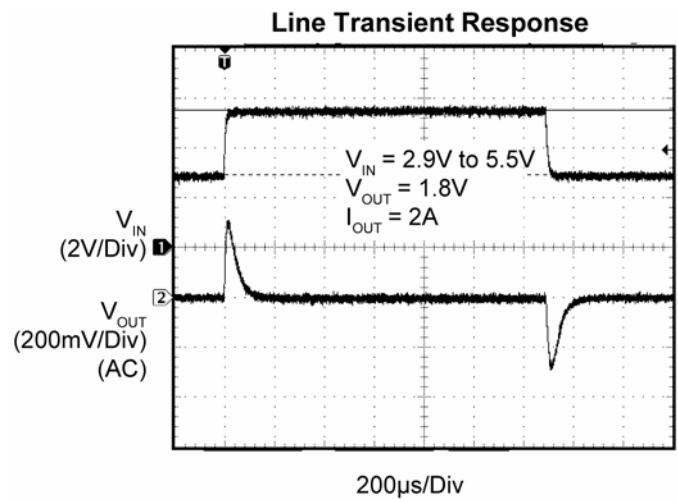
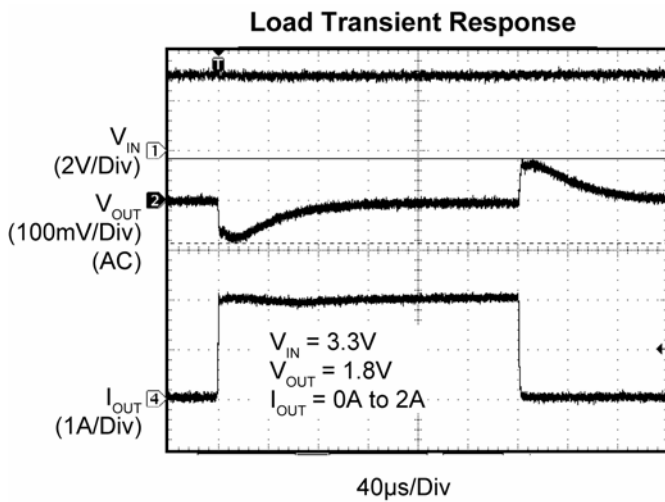
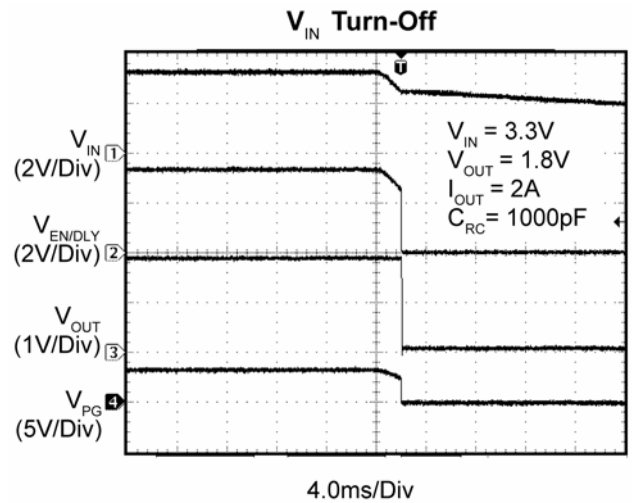
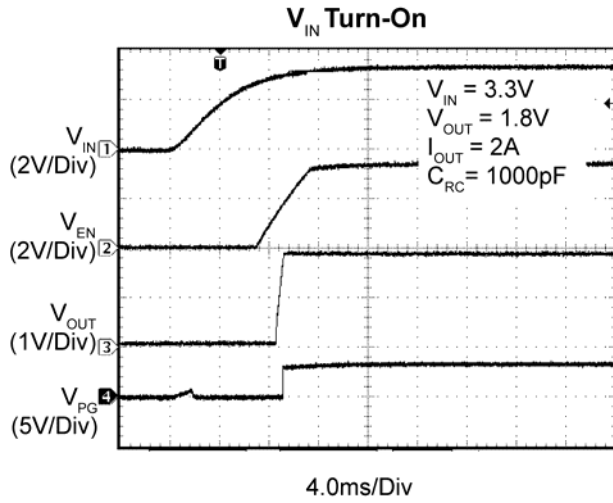

Evaluation Board Schematic

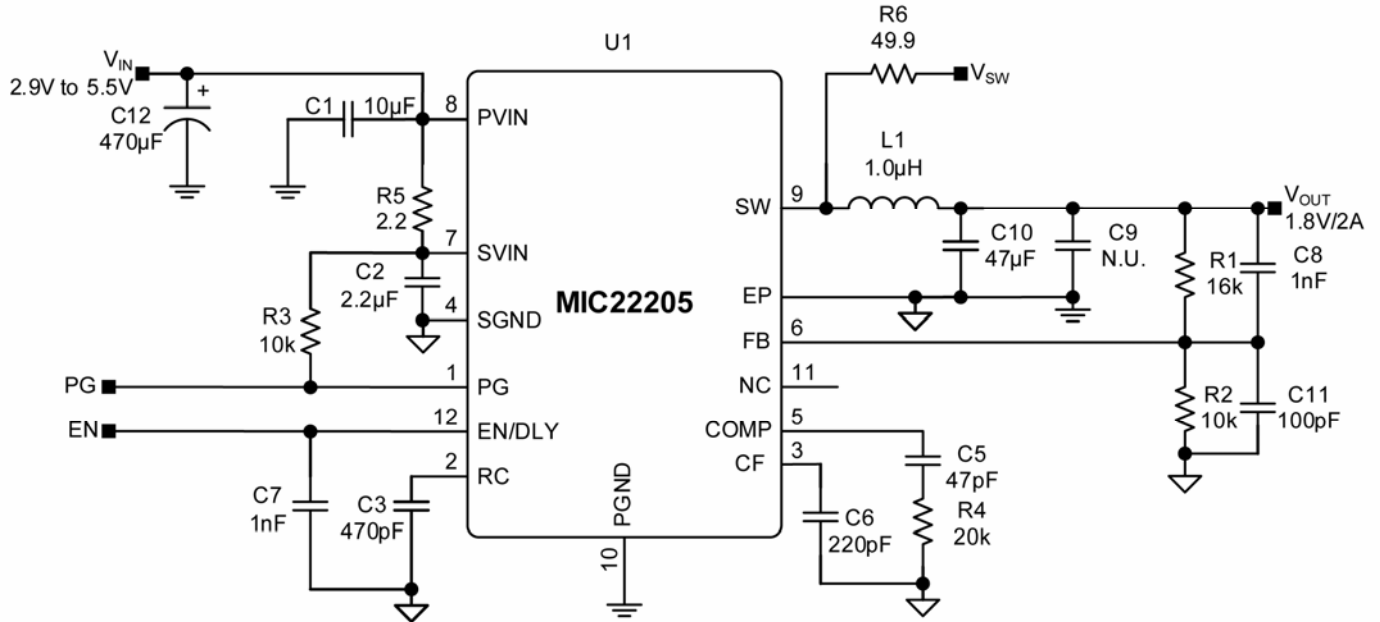

Bill of Materials

Item	Part Number	Manufacturer	Description	Qty.
C1	C2012X5R0J106K	TDK ⁽¹⁾	Capacitor, 10µF, 6.3V, X5R, Size 0805	1
	GRM2196R60J106K	Murata ⁽²⁾		
	08056D106KAT2A	AVX ⁽³⁾		
C2	C1608X5R0J225M	TDK	Capacitor, 2.2µF, 6.3V, X5R, Size 0603	1
	GRM188R60J225M	Murata		
	06036D225MAT2A	AVX		
C3	C1608X7RH471K	TDK	Capacitor, 470pF, 50V, X7R, Size 0603	
	GRM188R71H471KA01D	Murata		
	06035C471KAT2A	AVX		
C5	C1608C0G1H470J	TDK	Capacitor, 47pF, 50V, NPO, Size 0603	1
	GQM1885C1H470JB01D	Murata		
	06035A470JAT2A	AVX		
C6	C1608C0G1H221J	TDK	Capacitor, 220pF, 50V, NPO, Size 0603	1
	GRM1885C1H221JA01D	Murata		
	06035A221JAT2A	AVX		
C7, C8	C1608C0G1H102J	TDK	Capacitor, 1nF, 50V, NPO, Size 0603	2
	GRM1885C1H102JA01D	Murata		
	06035A102KAT2A	AVX		

Bill of Materials (Continued)

Item	Part Number	Manufacturer	Description	Qty.
C9	D.N.P.			
C10	C3216X5R0J476M	TDK	Capacitor, 47 μ F, 6.3V, X5R, Size 1206	1
	GRM31CR60J476ME19L	Murata		
	1206D476MAT2A	AVX		
C11	C1608C0G1H101J	TDK	Capacitor, 100pF, 50V, NPO Size 0603	1
	GRM1885C1H101JA01D	Murata		
	06035A101JAT2A	AVX		
C12	B41125A3477M	Epcos ⁽⁴⁾	470 μ F, 10V, Electrolytic, 8x10 case	1
L1	IHLP1616BZER1R0M11	Vishay ⁽⁵⁾	Inductor, 1 μ H, 5A	1
R1	CRCW06031602FKEA	AVX	Resistor, 16K, 1%, Size 0603	1
R2, R3	CRCW06031002FKEA	AVX	Resistor, 10K, 1%, Size 0603	2
R4	CRCW060320K0FKEA	AVX	Resistor, 20K, 1%, Size 0603	1
R5	CRCW06032R20FKEA	AVX	Resistor, 2.2 Ω , 1%, Size 0603	1
R6	CRCW060349R9FKEA	AVX	Resistor, 49.9 Ω , 1%, Size 0603	1
U1	MIC22205YML	Micrel ⁽⁶⁾	Integrated 2A Synchronous Buck Regulator	1

Notes:

1. TDK: www.tdk.com.
2. Murata: www.murata.com.
3. AVX: www.avx.com.
4. Epcos: www.epcos.com.
5. Vishay: www.vishay.com.
6. Micrel, Inc.: www.micrel.com.

Evaluation Board PCB Layout

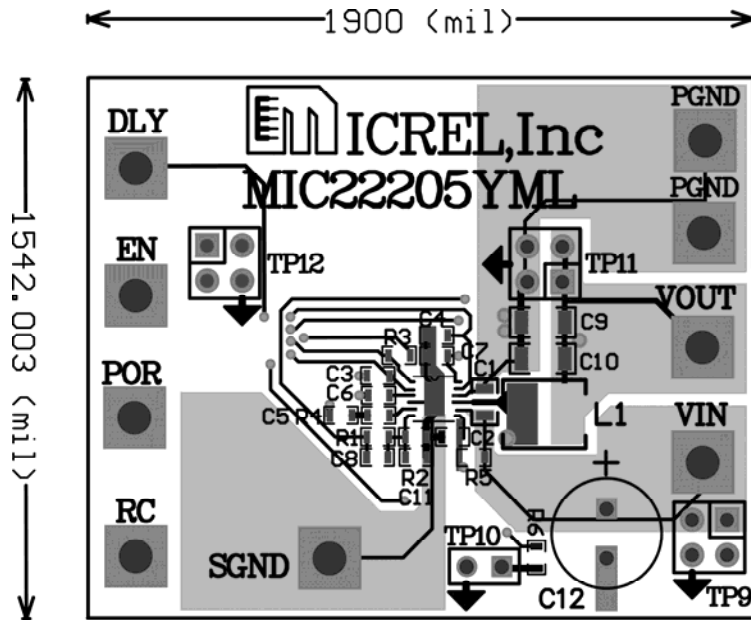

MIC22205 Evaluation Board Top Layer

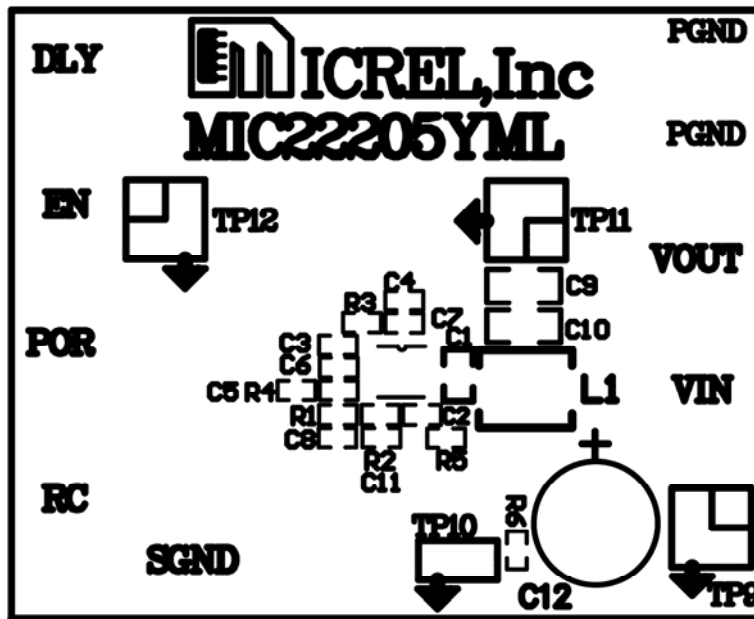

MIC22205 Evaluation Board Top Silk

Evaluation Board PCB Layout (Continued)

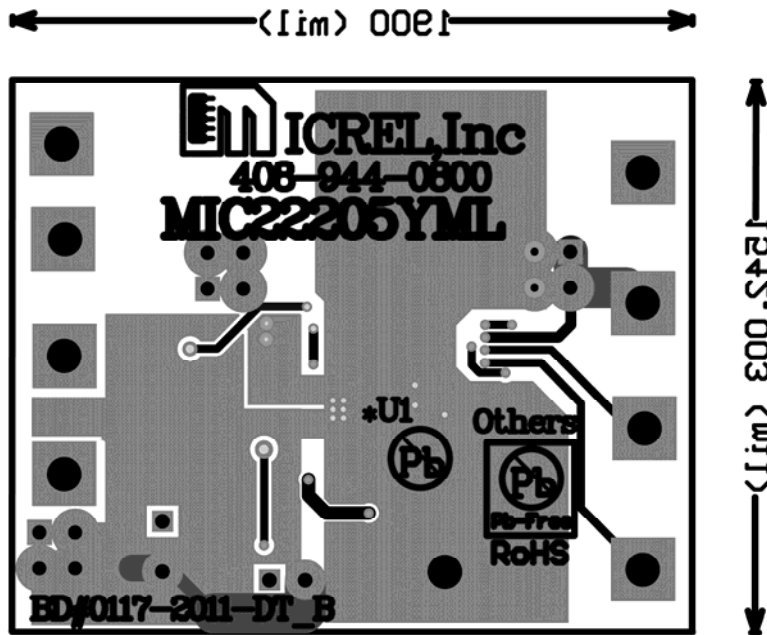

MIC22205 Evaluation Board Bottom Layer

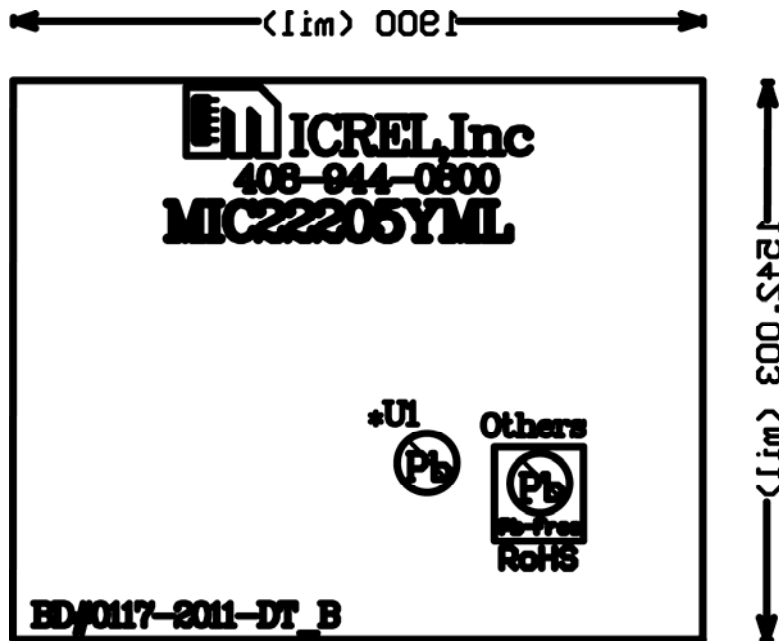

MIC22205 Evaluation Board Bottom Silk

MICREL, INC. 2180 FORTUNE DRIVE SAN JOSE, CA 95131 USA
TEL +1 (408) 944-0800 FAX +1 (408) 474-1000 WEB www.micrel.com

Micrel makes no representations or warranties with respect to the accuracy or completeness of the information furnished in this data sheet. This information is not intended as a warranty and Micrel does not assume responsibility for its use. Micrel reserves the right to change circuitry, specifications and descriptions at any time without notice. No license, whether express, implied, arising by estoppel or otherwise, to any intellectual property rights is granted by this document. Except as provided in Micrel's terms and conditions of sale for such products, Micrel assumes no liability whatsoever, and Micrel disclaims any express or implied warranty relating to the sale and/or use of Micrel products including liability or warranties relating to fitness for a particular purpose, merchantability, or infringement of any patent, copyright or other intellectual property right.

Micrel Products are not designed or authorized for use as components in life support appliances, devices or systems where malfunction of a product can reasonably be expected to result in personal injury. Life support devices or systems are devices or systems that (a) are intended for surgical implant into the body or (b) support or sustain life, and whose failure to perform can be reasonably expected to result in a significant injury to the user. A Purchaser's use or sale of Micrel Products for use in life support appliances, devices or systems is a Purchaser's own risk and Purchaser agrees to fully indemnify Micrel for any damages resulting from such use or sale.

© 2012 Micrel, Incorporated.