

Helping Customers Innovate, Improve & Grow

VT-803

Description

Vectron's VT-803 Temperature Compensated Crystal Oscillator (TCXO) is a quartz stabilized, clipped sine wave or CMOS output, 5th order analog temperature compensated oscillator, operating off a 2.8 to 5.0 volt supply in a hermetically sealed 3.2x5 mm ceramic package.

Features

- Clipped Sine Wave or CMOS Output
- 10.000-52.000 MHz Output
- ± 100 ppb Temperature Stability
- Optional Enable/Disable Function
- Optional VCXO
- Fundamental Crystal Design
- Gold over nickel contact pads
- Hermetically Sealed Ceramic SMD package
- Product is compliant to RoHS directive  and fully compatible with lead free assembly

Applications

- Stratum 3
- SyncE
- 1588
- Femto Cells
- Base Stations
- IP Networking
- GPS
- Point to Point Radio
- Manpack Radio
- Test and Measurement

Block Diagram

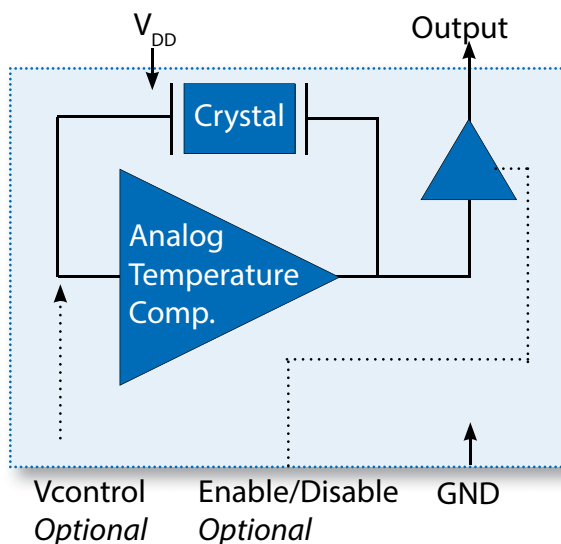

Specifications

Table 1. Electrical Performance, Clipped Sine Wave Option

| Parameter | Symbol | Min | Typ | Max | Units |
|--|-----------|--|------|---------------|------------|
| Output Frequency, ¹ <i>Ordering Option</i> | f_o | 10 | | 52 | MHz |
| Supply Voltage ² , <i>Ordering Option</i> | V_{DD} | +2.8, +3.0, +3.3, +5.0 | | | V |
| Supply Current, 10-20.000MHz 20.001-52.000MHz | I_{DD} | | | 2.0 3.4 | mA |
| Operating Temperature, <i>Ordering Option</i> | T_{OP} | -10/70, -20/70, -30/85, -40/85 | | | °C |
| Stability Over Operating Temperature ³ , <i>Ordering Option</i> | | ±0.100, ±0.200, ±0.280, ±0.500, ±1.0, ±2.0 | | | ppm |
| Initial Accuracy, "No Adjust" Option ⁴ | | | | ±1.5 | ppm |
| Power Supply Stability, ±5% change | | | | ±0.05 | ppm |
| Load Stability, ±10% change | | | | ±0.05 | ppm |
| Aging | | | | ±0.5 | ppm 1st yr |
| Stability, temperature and 24 hours ⁵ | | | | ±0.37 | ppm |
| Total Stability ⁵ | | | | ±4.6 | ppm |
| Pull Range, <i>Ordering Option</i> | PR | ±5, ±8, ±10, ±12 | | | ppm |
| Control Voltage to reach Pull Range | | 0.5 | | 2.5 | V |
| Control Voltage Impedance | | 100 | | | Kohm |
| Output Enable/Disable ⁶ , <i>Ordering Option</i> | | | | 0.8* V_{DD} | V |
| Output Enabled | V_{IH} | | | | V |
| Output Disabled (high impedance output) | V_{IL} | 0.2* V_{DD} | | | V |
| Output Level | V_o p/p | 0.8 | 1.1 | 1.3 | V |
| Output Load | | | | 10K 10pF | |
| Phase Noise, 26.000MHz | ϕ_N | | | | dBc/Hz |
| 10Hz | | | -91 | | |
| 100Hz | | | -117 | | |
| 1kHz | | | -136 | | |
| 10kHz | | | -150 | | |
| 100kHz | | | -158 | | |
| Start Up Time | t_{SU} | | | 2 | ms |

1. The Output is DC coupled.
2. The VT-803 power supply pin should be filtered, eg, a 10uF, 0.1uF and 0.01uf capacitor.
3. Not all stabilities are available over all temperature ranges. Measured at mid Vc for parts with frequency tuning.
4. After 2 IR reflows and 24 hours.
5. ±100, ±200 and ±280 ppb temp stability parts, all inclusive with 10 years aging.
6. Output is Enabled if E/D is left open.

Outline Drawing

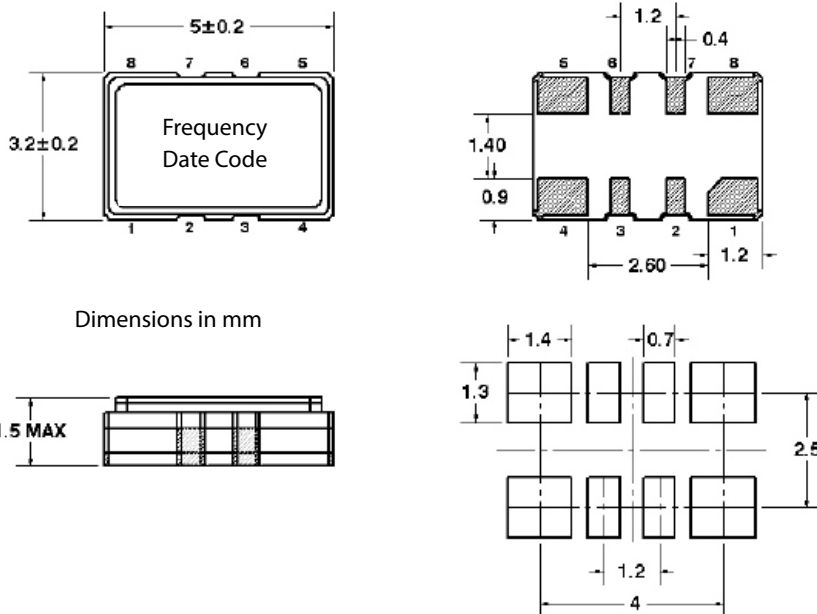

Table 2. Pinout

| Pin # | Symbol | Function |
|-------|-------------|---------------------------------------|
| 1 | NC or V_C | No Connection or TCXO Control Voltage |
| 2 | NC | Make No Connection |
| 3 | NC | Make No Connection |
| 4 | GND | Ground |
| 5 | OUT | Output |
| 6 | NC or E/D | No Connection or Enable/Disable |
| 7 | NC | Make No Connection |
| 8 | V_{DD} | Supply Voltage |

Table 3. Enable Disable Function (optional)

| Pin 6 | Pin 5 Output |
|-------|----------------|
| High | Clock Output |
| Open | Clock Output |
| Low | High Impedance |

Specifications

| Table 4. Electrical Performance, CMOS Option | | | | | |
|--|----------------------|--|-------------------------------------|----------------------------------|--------------------|
| Parameter | | Min | Typ | Max | Units |
| Output Frequency ¹ , <i>Ordering Option</i> | f_o | 10 | | 52 | MHz |
| Supply Voltage ² , <i>Ordering Option</i> | V_{DD} | +2.8, +3.0, +3.3, +5.0 | | | V |
| Supply Current, 10-24.999MHz 25.000-39.000MHz 40.000- 49.999MHz 50.000- 52.000MHz | I_{DD} | | | 3.0 3.5 5.0 6.0 | mA |
| Operating Temperature, <i>Ordering Option</i> | T_{OP} | -10/70, -20/70, -30/85, -40/85 | | | °C |
| Stability Over Operating Temperature ³ , <i>Ordering Option</i> | | ±0.100, ±0.200 ±0.280 ±0.500, ±1.0, ±2.0 | | | ppm |
| Initial Accuracy, "No Adjust" Option ⁴ | | | | ±1.5 | ppm |
| Power Supply Stability, ±5% change 10MHz-27MHz, 2.8V, 3.0V, and 3.3V >27MHz-52MHz, 2.8V, 3.0V, and 3.3V 10MHz-27MHz, 5V >27MHz-52MHz, 5V | | l | | ±0.10 ±0.20 ±0.20 ±0.30 | ppm |
| Load Stability, ±10% change | | | | ±0.10 | ppm |
| Aging | | | | ±0.5 | ppm 1st yr |
| Stability, temperature and 24 hours ⁵ | | | | ±0.37 | ppm |
| Total Stability ⁵ | | | | ±4.6 | ppm |
| Pull Range, <i>Ordering Option</i> | | ±5, ±8, ±10, ±12 | | | ppm |
| Control Voltage to reach Pull Range | | 0.5 | | 2.5 | V |
| Control Voltage Impedance | | 100 | | | Kohm |
| Output Enable/Disable ⁶ , <i>Ordering Option</i> Output Enabled Output Disabled (high impedance output) | V_{IH} V_{IL} | | $0.2 \cdot V_{DD}$ | $0.8 \cdot V_{DD}$ | V V |
| Output Level Output Logic High Output Logic Low Output Logic High Drive Output Logic Low Drive | V_{OH} V_{OL} | $0.9 \cdot V_{DD}$ 4 | | $0.1 \cdot V_{DD}$ -4 | V V mA mA |
| Output Load | | | | 15 | pF |
| Phase Noise, 26.000MHz 10Hz 100Hz 1kHz 10kHz 100kHz | | | -91 -117 -139 -153 -157 | | dBc/Hz |
| Period Jitter ⁷ rms peak-peak | | | 2.5 21.0 | | ps ps |
| Start Up Time | t_{SU} | | | 2 | ms |

1. The Output is DC coupled.
2. The VT-803 power supply pin should be filtered, eg, a 10uF, 0.1uF and 0.01uF capacitor.
3. Not all stabilities are available over all temperatures. Measured at mid Vc for parts with frequency tuning
4. After 2 IR reflows and 24 hours.
5. ±100, ±200 and ±280 ppb temp stability parts, all inclusive with 10 years aging.
6. Output is Enabled if E/D is left open.
7. Measured using a Wavecrest SIA3300C, 90K samples.

Warm Up Time

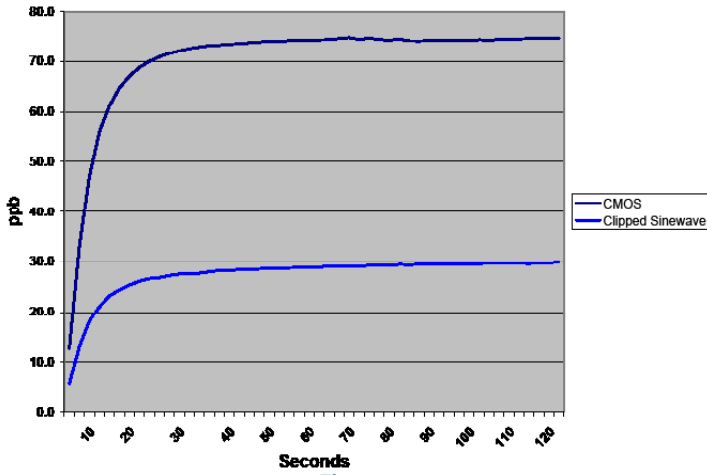

Figure 1

The VT-803 start up time is rated at 2ms. Figure 1 shows the Output Frequency versus time in seconds which shows the output reaching a steady state frequency within 60 seconds.

Frequency versus Vc Over Temperature

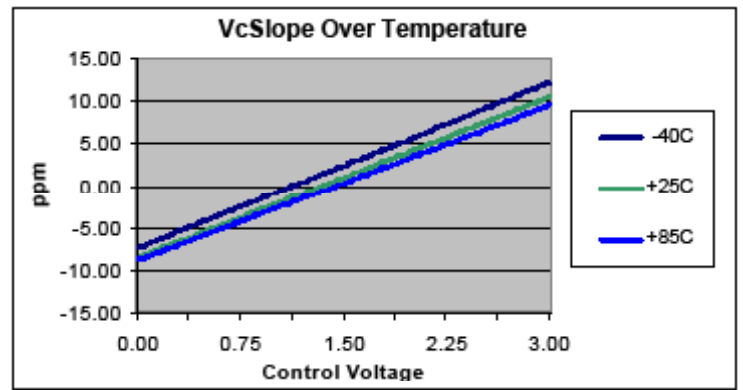

Figure 2

The VT-803 output frequency change versus control voltage is very linear and Figure 2 show the typical performance over temperature.

Allan Deviation, Clipped Sine Wave Output

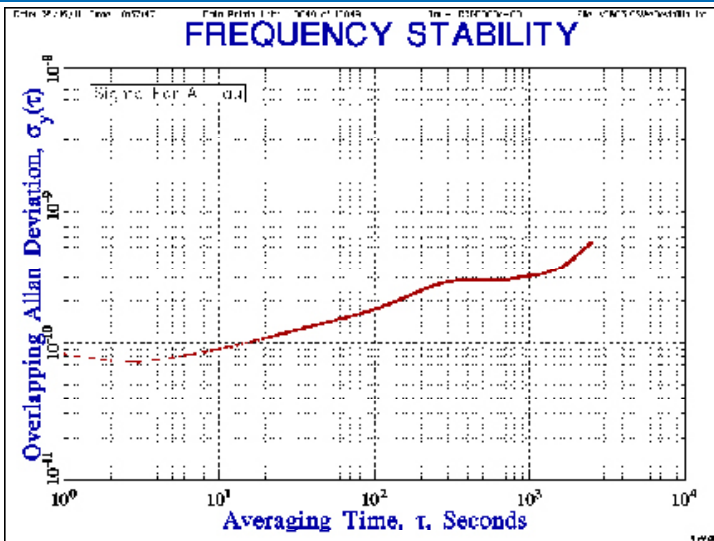

Figure 3

Test Conditions are under room ambient air flow (non insulated conditions).

Allan Deviation, CMOS Output

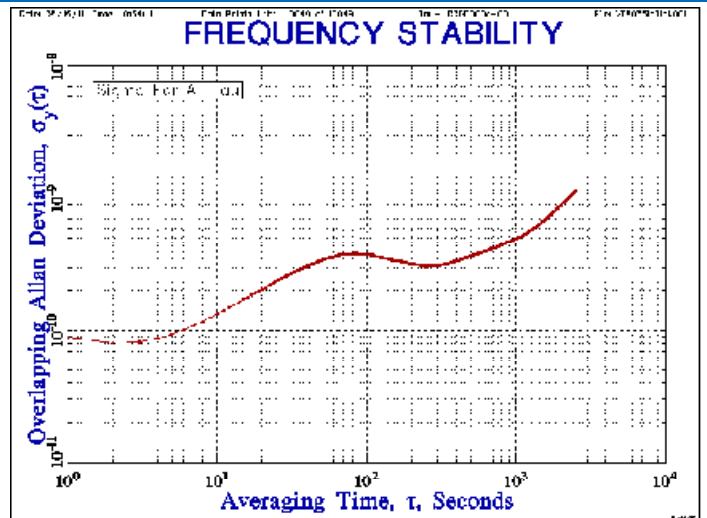

Figure 4

Test Conditions are under room ambient air flow (non insulated conditions).

Aging

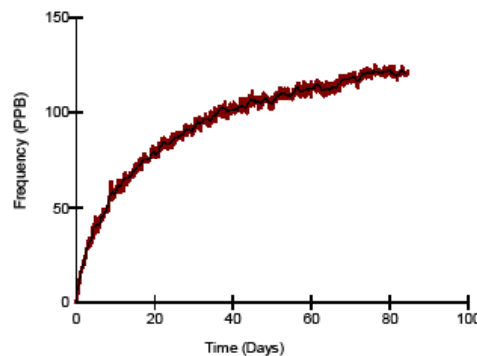
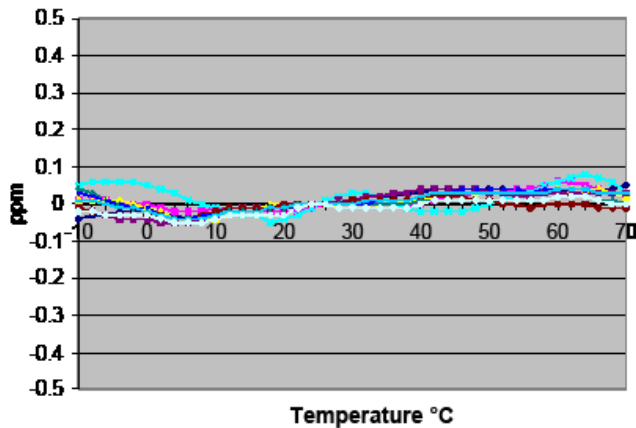

Figure 5

Figure 5 shows an output frequency change of 125ppb typical over 85 days at 85°C which would be equivalent to 125ppb over 2.25 years at 40°C.

Temperature Stability Graph



Temperature °C
Figure 6

Delta Frequency vs. Temperature

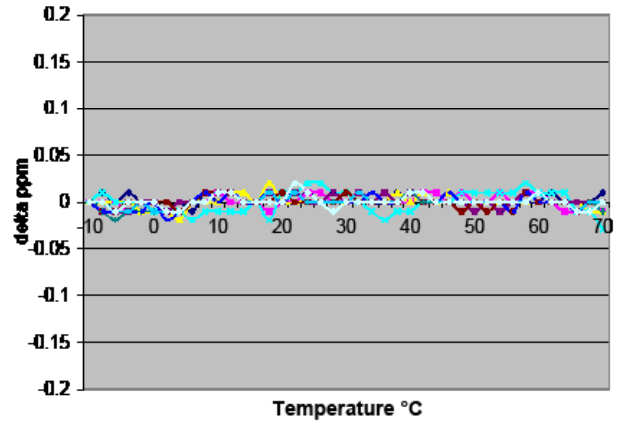

Figure 7

Figure 7 shows the change in frequency reading between every adjacent 2°C readings.

Phase Noise Performance, Clipped Sine Wave

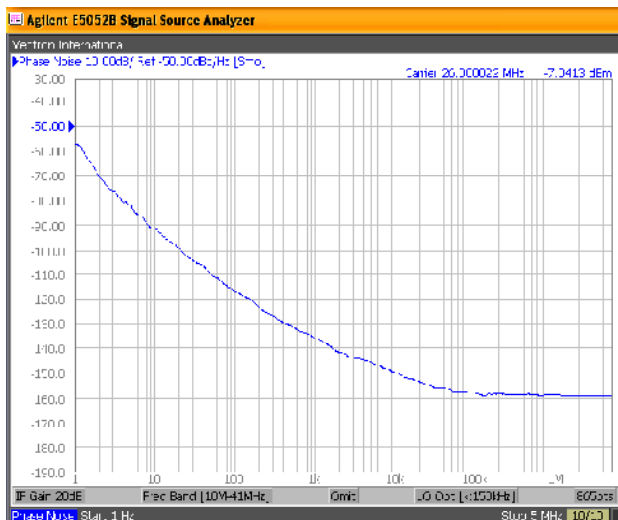

Figure 8

Phase Noise Performance, CMOS

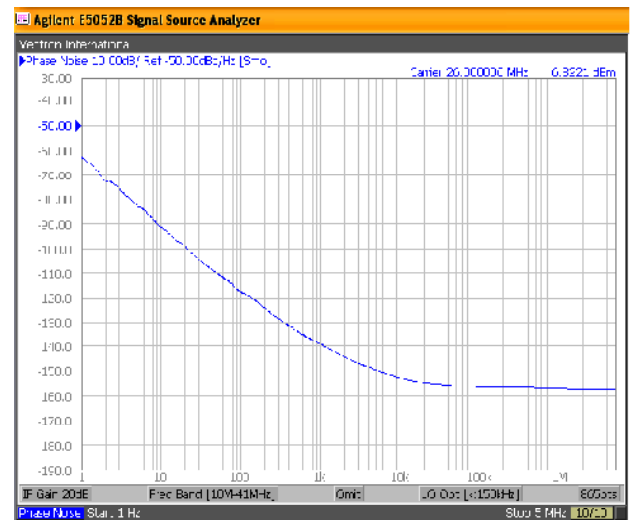

Figure 9

Phase Noise Over Temperature

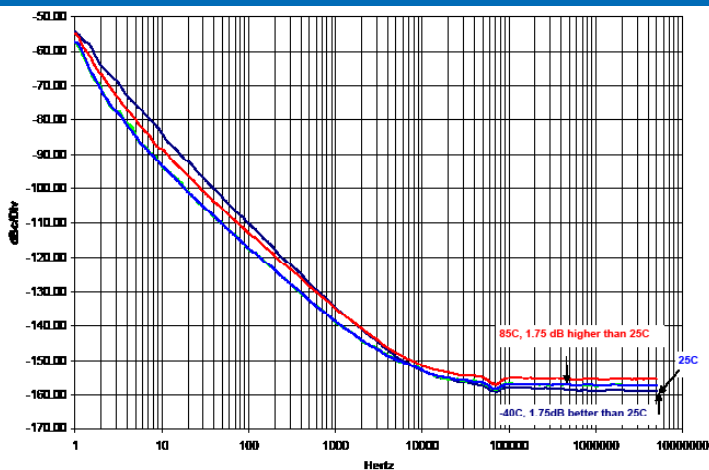

Figure 10

Figure 10 shows the difference in the phase noise at 85°C, 25°C and -40°C.

Phase Noise Over Power Supply Variation

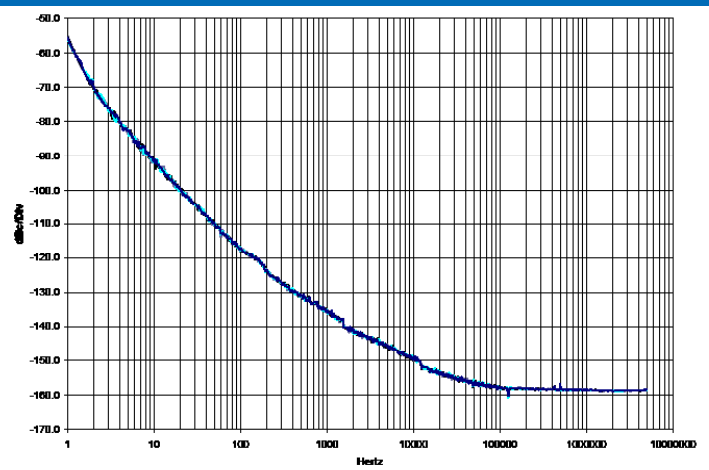

Figure 11

Figure 11 is a phase noise plot at a 2.8, 3.0, 3.3 and 3.6 volt power supply which demonstrates there is no significant change in performance.

VCXO Function

VCXO Feature: The VT-803 is supplied with a VCXO function for applications where it will be used in a PLL, or the output frequency needs fine tune or calibration adjustments. This is a high impedance input, 100 Kohm, and can be driven with an op-amp or terminated with adjustable resistors etc. **Pin 1 should not be left floating on the VCXO optional device.**

Maximum Ratings

Absolute Maximum Ratings and Handling Precautions

Stresses in excess of the absolute maximum ratings can permanently damage the device. Functional operation is not implied or any other excess of conditions represented in the operational sections of this data sheet. Exposure to absolute maximum ratings for extended periods may adversely affect device reliability.

Although ESD protection circuitry has been designed into the VT-803, proper precautions should be taken when handling and mounting, Vectron's employs a Human Body Model and Charged Device Model for ESD susceptibility testing and design evaluation. ESD thresholds are dependent on the circuit parameters used to define the model. Although no industry standard has been adopted for the CDM a standard resistance of 1.5kOhms and capacitance of 100pF is widely used and therefore can be used for comparison purposes.

| Parameter | Symbol | Rating | Unit |
|---------------------------|-------------|---------------------|------|
| Storage Temperature | T_{STORE} | -55/125 | °C |
| Supply Voltage | V_{DD} | -0.6/6 | V |
| Control Voltage | V_C | -0.6/ V_{DD} +0.6 | V |
| Enable/Disable Voltage | E/D | -0.6/ V_{DD} +0.6 | V |
| ESD, Human Body Model | | 1500 | V |
| ESD, Charged Device Model | | 1000 | V |

Reliability

| Parameter | Condition |
|----------------------------|--|
| Mechanical Shock | MIL-STD-883 Method 2002 (1500 G, 0.5 msec) |
| Mechanical Vibration | MIL-STD-883 Method 2007 (20 G Peak Acceleration) |
| Temperature Cycle | MIL-STD-883 Method 1010 (-55/85°C) |
| Solderability | MIL-STD-883 Method 2003 (Lead free solder) |
| Fine and Gross Leak | MIL-STD-883 Method 1014 (Crystal) |
| Resistance to Solvents | MIL-STD-883 Method 2015 (IPA solvent) |
| Moisture Sensitivity Level | MSL1 |
| Termination Finish | Gold (0.3-1.0um) over Nickel |
| Weight | 70 mg |
| ThetaJC (bottom of case) | 6 °C/W |

Test conditions: ±2.0 ppm change limit.

IR Reflow

Suggested IR Profile

Devices are built using lead free epoxy and can be subjected to standard lead free IR reflow conditions shown in Table 7. Contact pads are gold over nickel and lower maximum temperatures can also be used, such as 220°C.

| Table 7 Reflow Profile | | |
|----------------------------------|---------------------------|-------------------------------|
| Parameter | Symbol | Value |
| PreHeat Time Ts-min Ts-max | t_s | 200 sec Max 150°C 200°C |
| Ramp Up | R_{UP} | 3°C/sec Max |
| Time above 217C | t_L | 150 sec Max |
| Time to Peak Temperature | $t_{25C \text{ to peak}}$ | 480 sec Max |
| Time at 260C | t_p | 30 sec Max |
| Time at 240C | t_{p2} | 60 sec Max |
| Ramp down | R_{DN} | 6°C/sec Max |

Solderprofile:

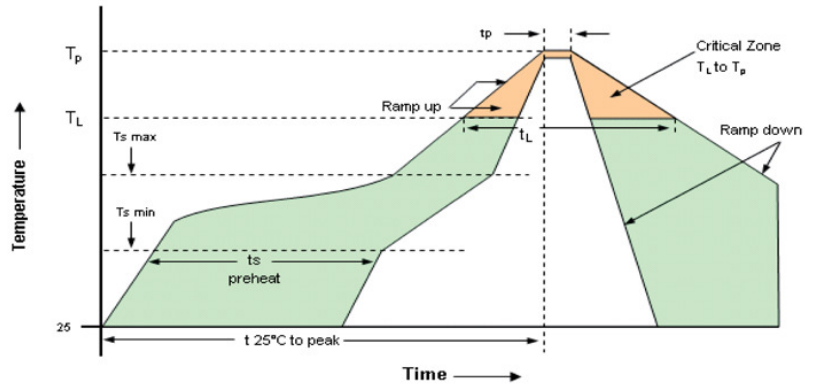

Tape & Reel

Table 8. Tape and Reel Information

| Tape Dimensions (mm) | | | | | | Reel Dimensions (mm) | | | | | | |
|----------------------|-----|-----|----|----|-----|----------------------|----|----|-----|------|------|--------|
| W | F | Do | Po | P1 | A | B | C | D | N | W1 | W2 | #/Reel |
| 12 | 5.5 | 1.5 | 4 | 8 | 254 | 2.5 | 13 | 21 | 100 | 13.5 | 17.5 | 2000 |

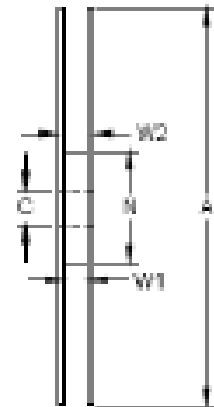
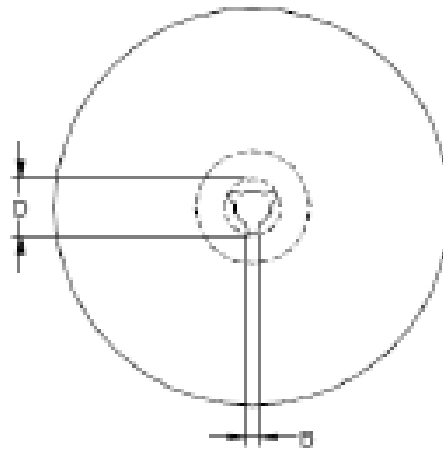
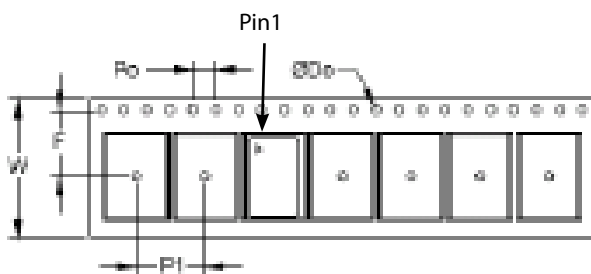

Ordering Information

Table 9. Standard Frequencies (MHz)

| | | | | | | | | | |
|--------|--------|--------|--------|--------|--------|--------|--------|--------|--------|
| 10.000 | 12.800 | 16.000 | 16.384 | 16.800 | 19.200 | 19.440 | 20.000 | 20.480 | 24.000 |
| 24.576 | 25.000 | 26.000 | 27.000 | 28.800 | 29.792 | 30.000 | 30.720 | 31.250 | 32.000 |
| 33.333 | 36.000 | 38.400 | 38.880 | 39.000 | 40.000 | 48.000 | 49.152 | 50.000 | 52.000 |

VT-803- E A H - 507A- xxMxxxxxxx *

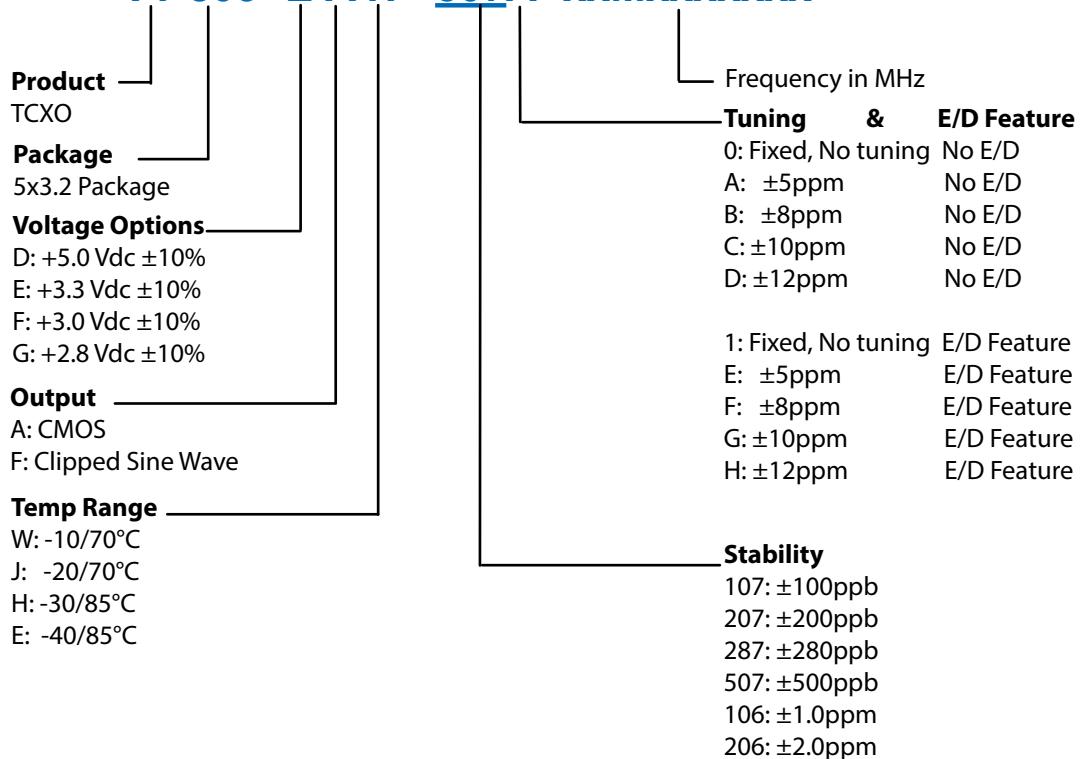

* Add **_SNPBDIP** for tin lead solder dip
Example: VT-803-EAE-2870-40M0000000_**_SNPBDIP**

| Revision Date | Description |
|---------------|---|
| Nov 4, 2013 | Updated product capability chart (Table 9 & 10). Changed VI Asia contact information. |
| Jan 7, 2014 | Added "temperature stability measurement at Mid Vc for parts with frequency tuning option". Removed Delta 1s Frequency Plot. |
| Feb 18, 2014 | Added temp stability measurement condition on parts with Vc feature. Changed Vectron logo and Hudson contact information. |
| Sep 3, 2014 | Modified Package Drawing Orientation, added tuningI slope (positive), red bullet in Capability Chart |
| June 28, 2018 | Add: E/D function, E/D specifications, E/D Table. New Frequencies, Stratum3/SyncE, ±4.6ppm overall stability, ±0.37ppm temperature plus 24 hours (for stabilities ≤ ±280ppb), weight and thetaJC. Updated CMOS load and power supply stability. Update test conditions and clipped sine wave current limit >26MHz to 52MHz. Add new Table 3; Enable/Disable Table. Deleted Capabilities Tables 9 and 10. Add _SNPBDIP ordering option and example. Change Vectron logo to Microsemi/Microchip. |
| Sep12, 2018 | Updated contact information, added (bottom of case) to the thetaJC parameter, added max swing in clipped sine wave /Table1 |



Microsemi Headquarters

One Enterprise, Aliso Viejo, CA 92656 USA
Within the USA: +1 (800) 713-4113
Outside the USA: +1 (949) 380-6100
Sales: +1 (949) 380-6136
Fax: +1 (949) 215-4996
email: sales.support@microsemi.com
www.microsemi.com

Microsemi, a wholly owned subsidiary of Microchip Technology Inc. (Nasdaq: MCHP), offers a comprehensive portfolio of semiconductor and system solutions for aerospace & defense, communications, data center and industrial markets. Products include high-performance and radiation-hardened analog mixed-signal integrated circuits, FPGAs, SoCs and ASICs, power management products, timing and synchronization devices and precise time solutions, setting the world's standard for time; voice processing devices; RF solutions; discrete components; enterprise storage and communication solutions, security technologies and scalable anti-tamper products; Ethernet solutions; Power-over-Ethernet ICs and midspans; as well as custom design capabilities and services. Learn more at www.microsemi.com.

Microsemi makes no warranty, representation, or guarantee regarding the information contained herein or the suitability of its products and services for any particular purpose, nor does Microsemi assume any liability whatsoever arising out of the application or use of any product or circuit. The products sold hereunder and any other products sold by Microsemi have been subject to limited testing and should not be used in conjunction with mission-critical equipment or applications. Any performance specifications are believed to be reliable but are not verified, and Buyer must conduct and complete all performance and other testing of the products, alone and together with, or installed in, any end-products. Buyer shall not rely on any data and performance specifications or parameters provided by Microsemi. It is the Buyer's responsibility to independently determine suitability of any products and to test and verify the same. The information provided by Microsemi hereunder is provided "as is, where is" and with all faults, and the entire risk associated with such information is entirely with the Buyer. Microsemi does not grant, explicitly or implicitly, to any party any patent rights, licenses, or any other IP rights, whether with regard to such information itself or anything described by such information. Information provided in this document is proprietary to Microsemi, and Microsemi reserves the right to make any changes to the information in this document or to any products and services at any time without notice.

©2018 Microsemi, a wholly owned subsidiary of Microchip Technology Inc. All rights reserved. Microsemi and the Microsemi logo are registered trademarks of Microsemi Corporation. All other trademarks and service marks are the property of their respective owners.