



# APPLICATION SPECIFICATION

## TITLE

### GPS L1/L5 & GLONASS 36MM STACKED PATCH SINGLE FEED

## TABLE OF CONTENTS

1.0 SCOPE

2.0 PRODUCT DESCRIPTION

3.0 APPLICABLE DOCUMENTS

4.0 ANTENNA PERFORMANCE

5.0 RF PERFORMANCE AS A FUNCTION OF IMPLEMENTATION

REVISION: <b>A</b>	ECR/ECN INFORMATION: EC No: 609778 DATE: 2019/03/07	TITLE: <b>GPS L1/L5 &amp; Glonass 36mm Stacked Patch Sing Feed Application Specification</b>	SHEET No. <b>1 of 36</b>
DOCUMENT NUMBER: <b>AS-2116240001</b>	CREATED / REVISED BY: Liu Hai 2019/03/05	CHECKED BY: Cheng Kang 2019/03/05	APPROVED BY: Andy Zhang 2019/03/05

## GPS L1/L5 & GLONASS 36MM STACKED PATCH SING FEED

### 1.0 SCOPE

This specification describes the antenna application and surrounding. The information in this document is for reference and benchmark purposes only. The user is responsible for validating antenna RF performance based on the user's actual implementation.

All measurements are done of the antenna mounted on the recommended PCB with VNA Agilent 5071C and OTA chamber.

Antenna illustrations in this document are generic representations. They are not intended to be an image of any antenna listed in the scope.

### 2.0 PRODUCT DESCRIPTION

#### 2.1 PRODUCT NAME AND SERIES NUMBER (S)

Product Name: GPS L1/L5 & Glonass 36mm stacked patch single feed

Series Number: 211624

#### 2.2 DESCRIPTION

211624 is a 36x36mm and 25x25mm two ceramic patch stacked for GPS L1/L5 & Glonass. It's designed for high precision tracking applications: UAV and drones, Vehicle tracking...

#### 2.3 PRODUCT STRUCTURE INFORMATION

Please refer to PS-2116240001 for full information.



Molex 2116240001 GPS L1/L5 & Glonass 36mm stacked patch single feed 3D View

REVISION: <b>A</b>	ECR/ECN INFORMATION: EC No: 609778 DATE: 2019/03/07	TITLE: <b>GPS L1/L5 &amp; Glonass 36mm Stacked Patch Sing Feed Application Specification</b>	SHEET No. <b>2 of 36</b>
DOCUMENT NUMBER: <b>AS-2116240001</b>	CREATED / REVISED BY: Liu Hai 2019/03/05	CHECKED BY: Cheng Kang 2019/03/05	APPROVED BY: Andy Zhang 2019/03/05

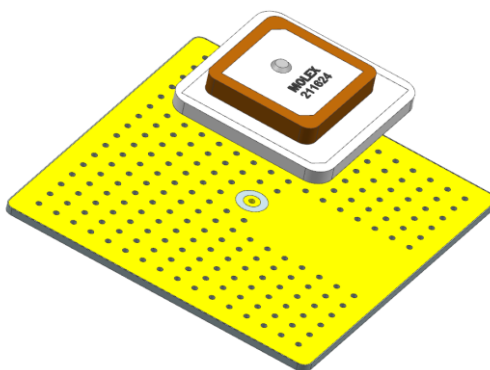
### 3.0 APPLICABLE DOCUMENTS

DOCUMENT	NUMBER	DESCRIPTION
Sale Drawing (SD)	SD-2116240001	Mechanical Dimension of the product
Product Specification (PS)	PS-2116240001	Product Specification
Packing Drawing (PK)	PK-2116240001	Product packaging specifications

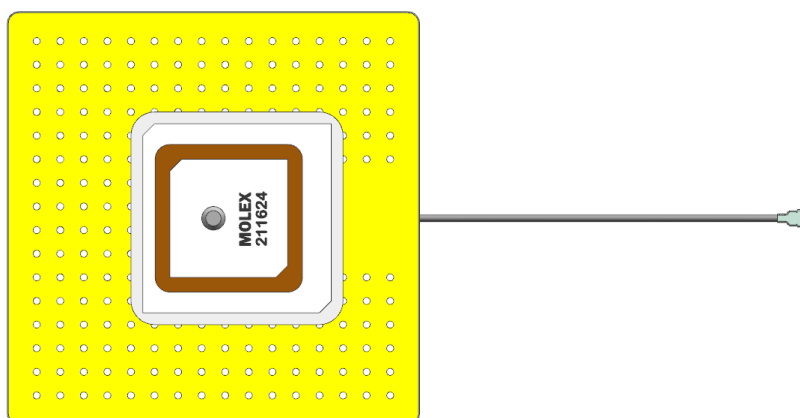
### 4.0 ANTENNA PERFORMANCE

#### 4.1 TEST ASSEMBLY INSTRUCTIONS

THE FOLLOWING STEPS ARE FOR ASSEMBLY INSTRUCTION:

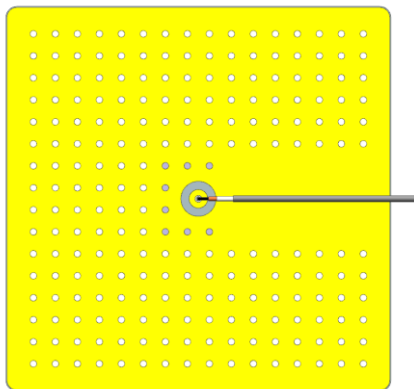


Release the liner and stick the antenna on the PCB



The PCB size is 70mm\*70mm\*1.5mm

REVISION: <b>A</b>	ECR/ECN INFORMATION: EC No: 609778 DATE: 2019/03/07	TITLE: <b>GPS L1/L5 &amp; Glonass 36mm Stacked Patch Sing Feed Application Specification</b>	SHEET No. <b>3 of 36</b>
DOCUMENT NUMBER: <b>AS-2116240001</b>	CREATED / REVISED BY: Liu Hai 2019/03/05	CHECKED BY: Cheng Kang 2019/03/05	APPROVED BY: Andy Zhang 2019/03/05



Solder antenna pin on PCB

The Antenna is fixed and soldered at the center of reference PCB with the size of 70mm\*70mm and the test coaxial cable length is 100mm.

#### 4.2 RF TEST CONDITIONS

All measurements are done of the antenna mounted on a 70\*70mm PCB with VNA Agilent E5071C and Over-The-Air (OTA) chamber. All measurements in this document are done with the part no.2116240001 with reference PCB.

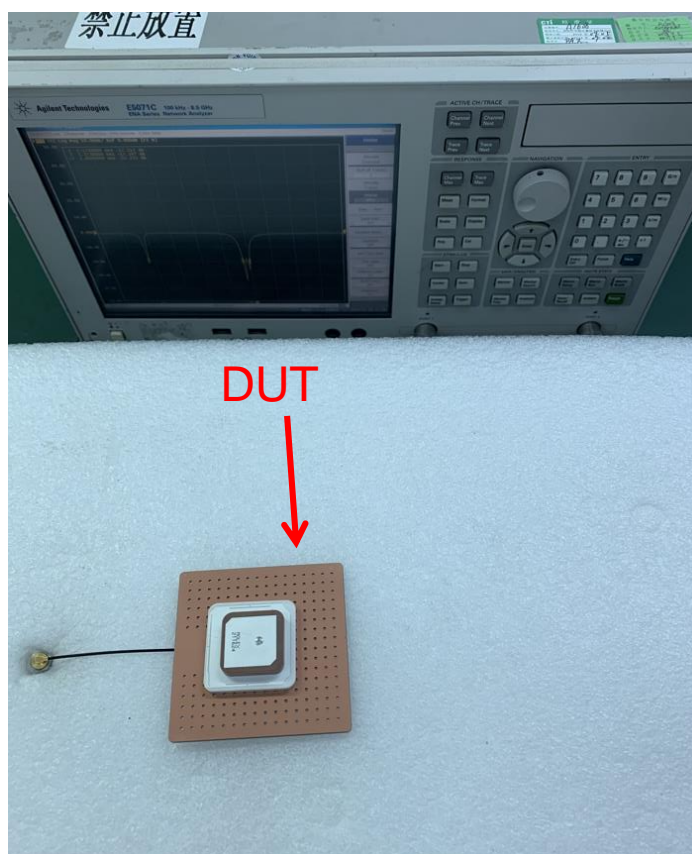
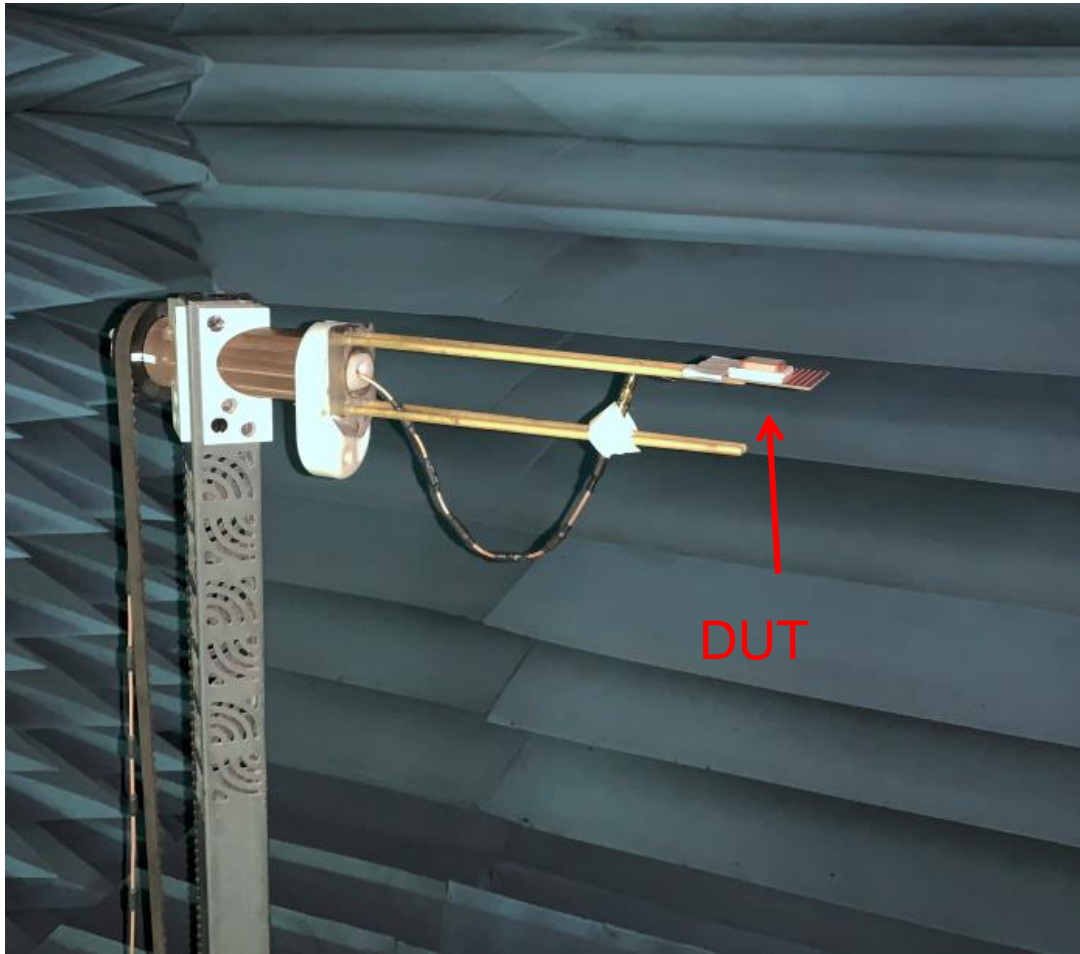


FIGURE4.2.1 ANTENNA LOADED WITH REFERENCE PCB WITH VNA

REVISION: <b>A</b>	ECR/ECN INFORMATION: EC No: 609778 DATE: 2019/03/07	TITLE: <b>GPS L1/L5 &amp; Glonass 36mm Stacked Patch Sing Feed Application Specification</b>	SHEET No. <b>4 of 36</b>
DOCUMENT NUMBER: <b>AS-2116240001</b>	CREATED / REVISED BY: Liu Hai 2019/03/05	CHECKED BY: Cheng Kang 2019/03/05	APPROVED BY: Andy Zhang 2019/03/05



**FIGURE4.2.2 ANTENNA LOADED WITH REFERENCE PCB WITH OTA CHAMBER**

REVISION:  <b>A</b>	ECR/ECN INFORMATION: EC No: 609778 DATE: 2019/03/07	TITLE: <b>GPS L1/L5 &amp; Glonass 36mm Stacked Patch Sing Feed Application Specification</b>		SHEET No.  <b>5 of 36</b>
DOCUMENT NUMBER: <b>AS-2116240001</b>		CREATED / REVISED BY: Liu Hai 2019/03/05	CHECKED BY: Cheng Kang 2019/03/05	APPROVED BY: Andy Zhang 2019/03/05



# APPLICATION SPECIFICATION

## 4.3 ANTENNA PERFORMANCE

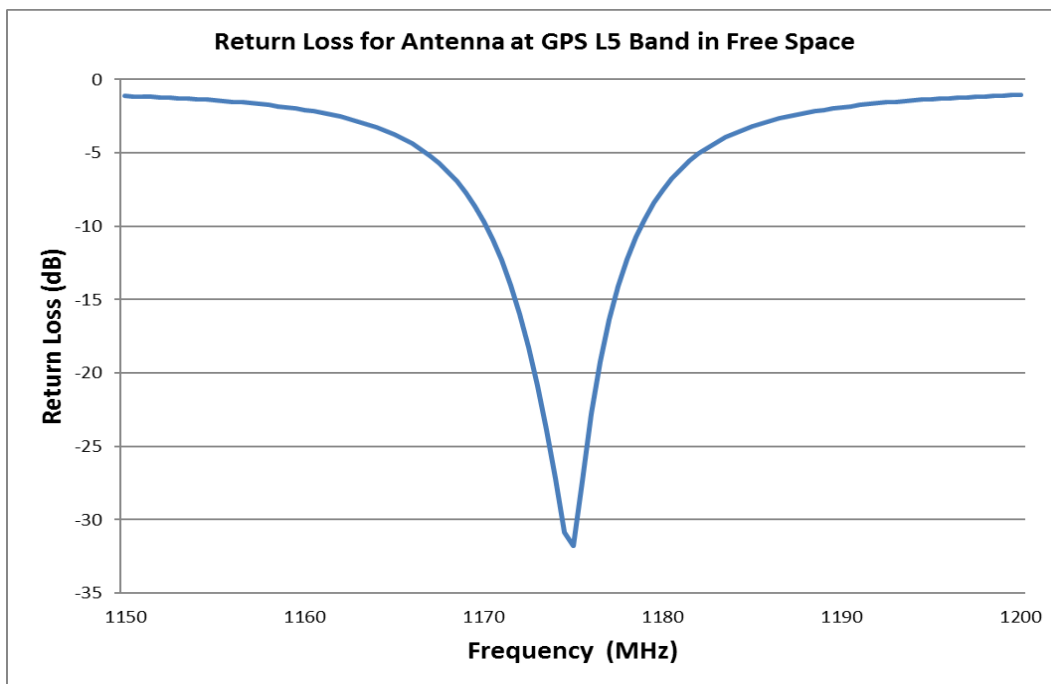
DESCRIPTION	EQUIPMENT	REQUIREMENT		
		GSP L5: 1176.45MHz	GPS L1: 1575.42 MHz	GLONASS L1: 1602 MHz
Frequency Range	VNA E5071C			
Return Loss	VNA E5071C	<- 10dB		
Peak Gain (Max)	OTA Chamber	2.1dBi	4.5dBi	4.2dBi
Average Total Efficiency	OTA Chamber	>60%	>75%	>70%
Polarization	OTA Chamber	RHCP		
Input Impedance	VNA E5071C	50 ohms		

Note that the above antenna performance is measured with just the antenna mounted on a 70\*70mm PCB to similar a free-space condition. When implement into the system, the frequency resonant might be off-tune due to the loading of surrounding components especially metal plane. This off-tune can be compensated through matching. Although module manufacturers specify a peak gain limit, it is based on free-space conditions. The peak gain will be degraded by 1 to 2dBi in the actual implementation as the radiation pattern will change due to the surround components. As such, during selection of antenna, you can select one with high peak gain to compensate for the loss. Molex can offer assistant to choose the best location and best tuning in-order to meet this peak gain requirement.

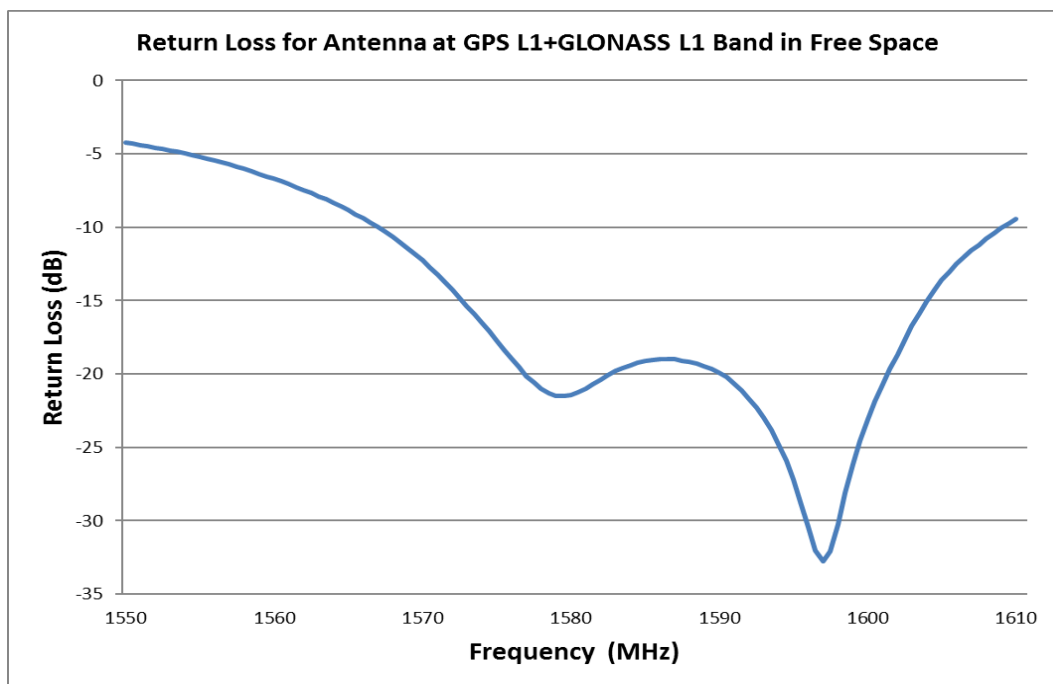
<b>REVISION:</b> <b>A</b>	<b>ECR/ECN INFORMATION:</b> EC No: <b>609778</b> DATE: <b>2019/03/07</b>	<b>TITLE:</b> <b>GPS L1/L5 &amp; Glonass 36mm Stacked Patch Sing Feed Application Specification</b>	<b>SHEET No.</b> <b>6 of 36</b>
<b>DOCUMENT NUMBER:</b> <b>AS-2116240001</b>	<b>CREATED / REVISED BY:</b> Liu Hai 2019/03/05	<b>CHECKED BY:</b> Cheng Kang 2019/03/05	<b>APPROVED BY:</b> Andy Zhang 2019/03/05

## 4.4 RETURN LOSS PLOT

All measurements in this document are done on the reference PCB.



**FIGURE 4.4.1 RETURN LOSS OF ANTENNA AT GPS L5 BAND IN FREE SPACE**

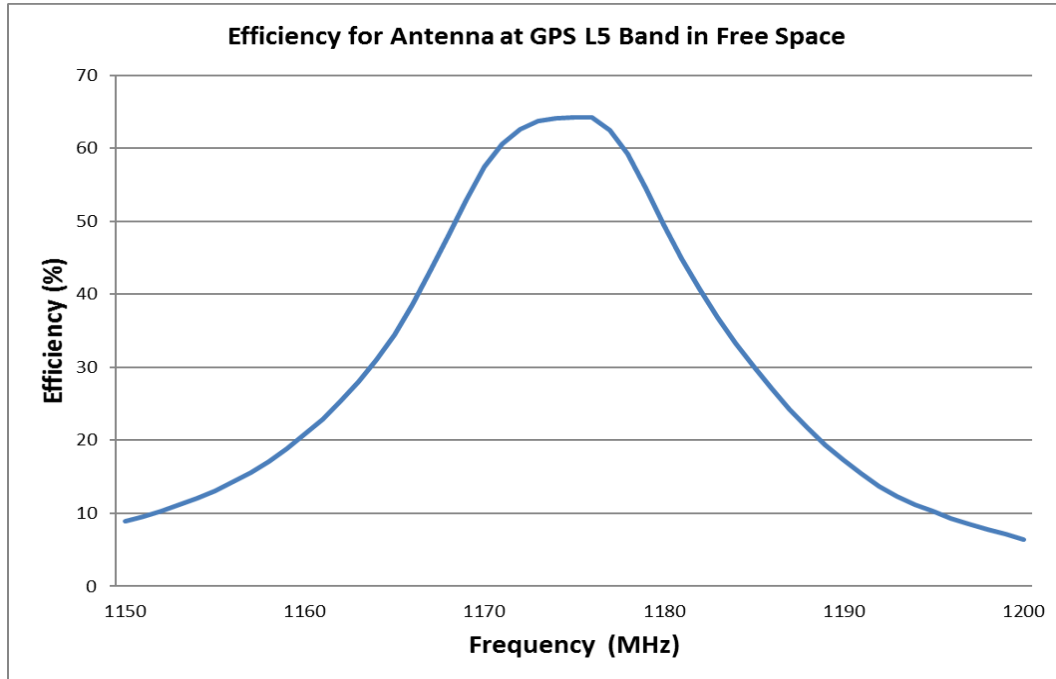


**FIGURE 4.4.2 RETURN LOSS OF ANTENNA AT GPS L1+GLONASS L1 BAND IN FREE SPACE**

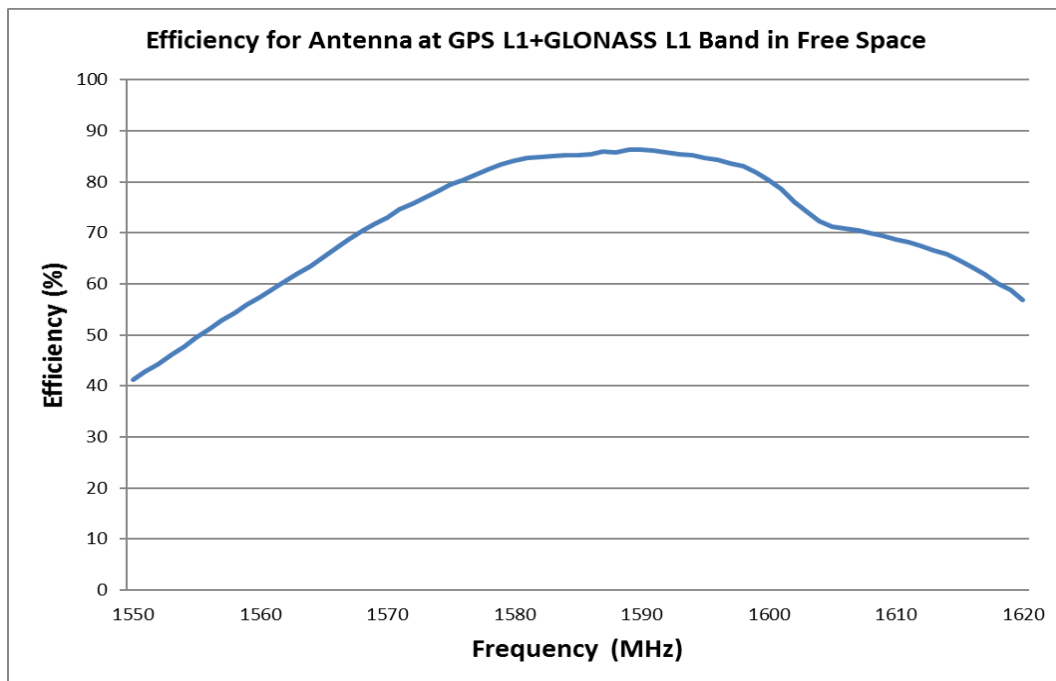
REVISION: <b>A</b>	ECR/ECN INFORMATION: EC No: 609778 DATE: 2019/03/07	TITLE: <b>GPS L1/L5 &amp; Glonass 36mm Stacked Patch Sing Feed Application Specification</b>	SHEET No. <b>7 of 36</b>
DOCUMENT NUMBER: <b>AS-2116240001</b>	CREATED / REVISED BY: Liu Hai 2019/03/05	CHECKED BY: Cheng Kang 2019/03/05	APPROVED BY: Andy Zhang 2019/03/05

## 4.5 EFFICIENCY PLOT

All measurements in this document are done on the reference PCB.



**FIGURE 4.5.1 EFFICIENCY OF ANTENNA AT GPS L5 BAND IN FREE SPACE**

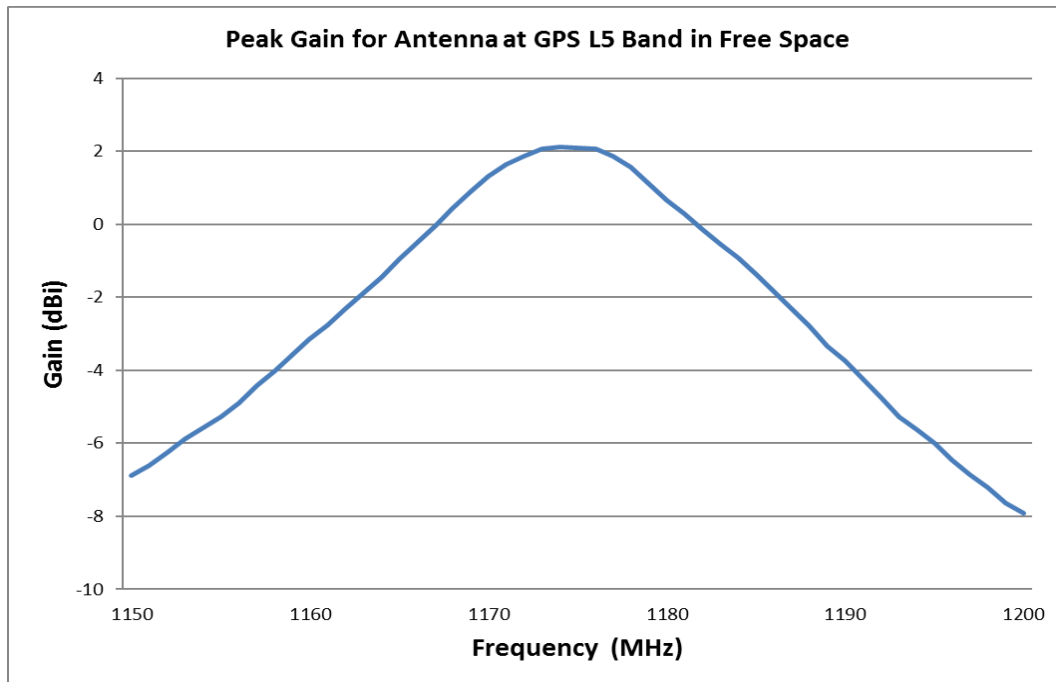


**FIGURE 4.5.2 EFFICIENCY OF ANTENNA AT GPS L1+GLONASS L1 BAND IN FREE SPACE**

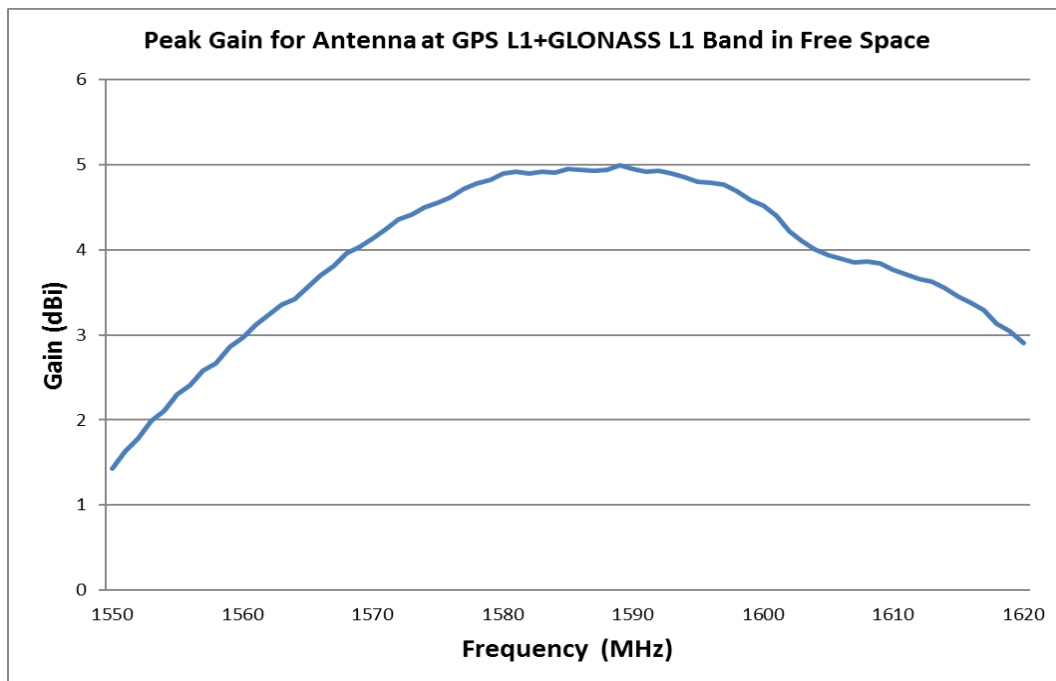
REVISION: <b>A</b>	ECR/ECN INFORMATION: EC No: 609778 DATE: 2019/03/07	TITLE: <b>GPS L1/L5 &amp; Glonass 36mm Stacked Patch Sing Feed Application Specification</b>	SHEET No. <b>8 of 36</b>
DOCUMENT NUMBER: <b>AS-2116240001</b>	CREATED / REVISED BY: Liu Hai 2019/03/05	CHECKED BY: Cheng Kang 2019/03/05	APPROVED BY: Andy Zhang 2019/03/05

## 4.6 PEAK GAIN PLOT

All measurements in this document are done on the reference PCB.



**FIGURE 4.6.1 PEAK GAIN OF ANTENNA AT GPS L5 BAND IN FREE SPACE**

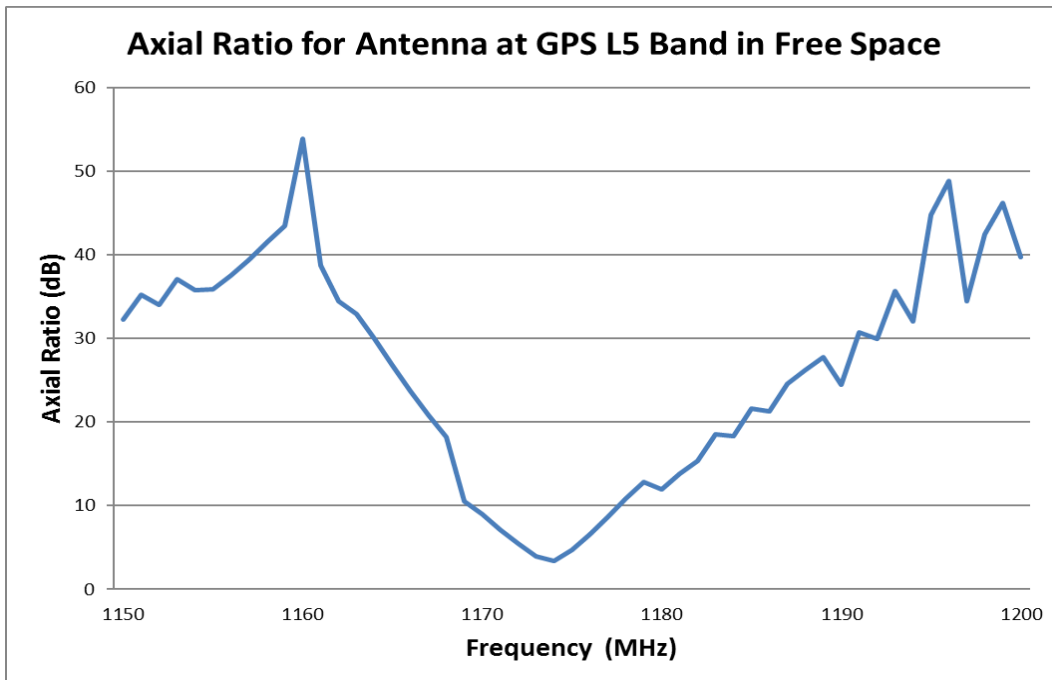


**FIGURE 4.6.2 PEAK GAIN OF ANTENNA AT GPS L1+GLONASS L1 BAND IN FREE SPACE**

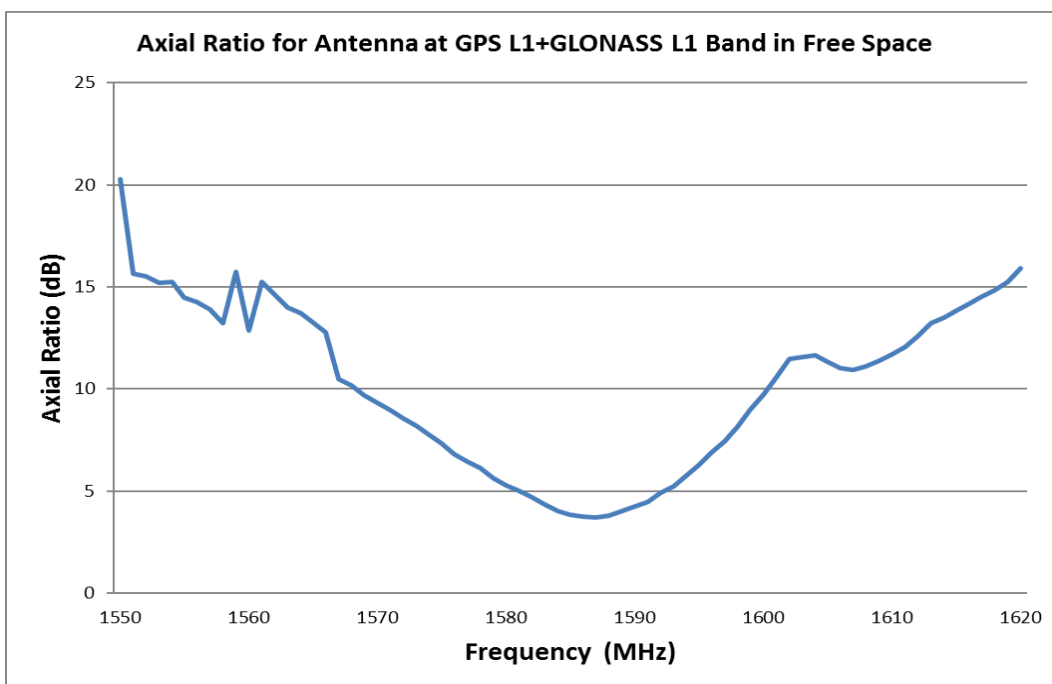
REVISION: <b>A</b>	ECR/ECN INFORMATION: EC No: 609778 DATE: 2019/03/07	TITLE: <b>GPS L1/L5 &amp; Glonass 36mm Stacked Patch Sing Feed Application Specification</b>	SHEET No. <b>9 of 36</b>
DOCUMENT NUMBER: <b>AS-2116240001</b>	CREATED / REVISED BY: Liu Hai 2019/03/05	CHECKED BY: Cheng Kang 2019/03/05	APPROVED BY: Andy Zhang 2019/03/05

## 4.7 AXIAL RATIO PLOT

All measurements in this document are done on the reference PCB.



**FIGURE 4.7.1 AXIAL RATIO OF ANTENNA AT GPS L5 BAND IN FREE SPACE**

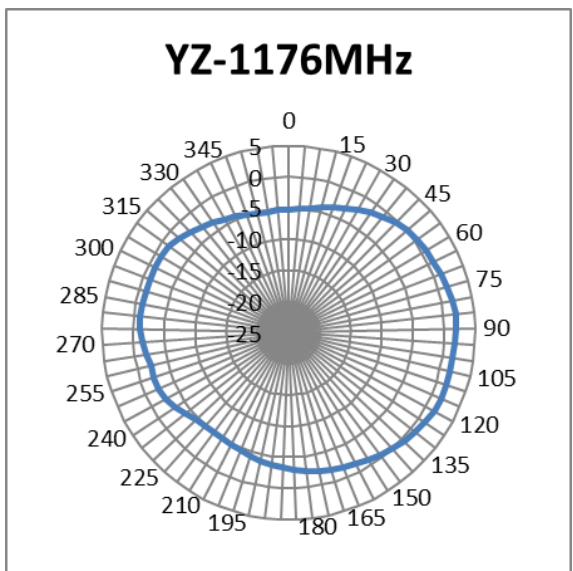
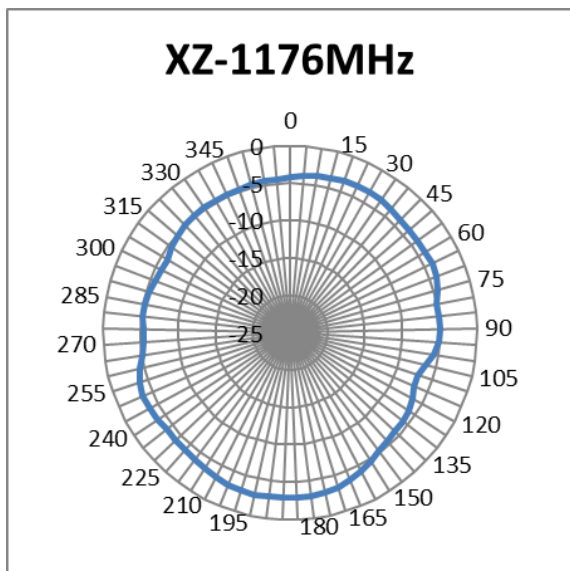
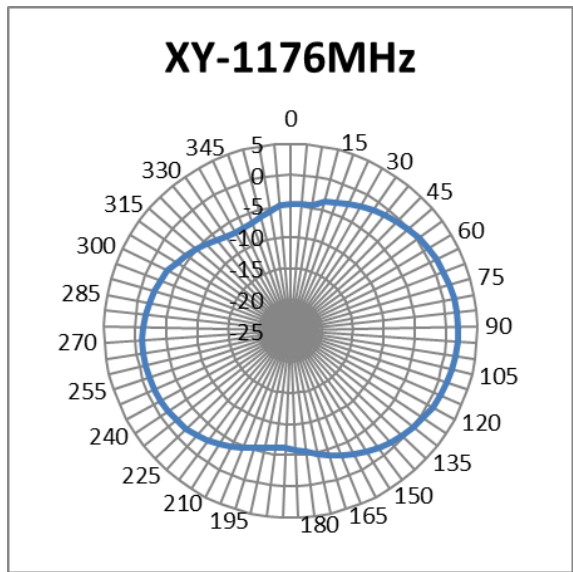
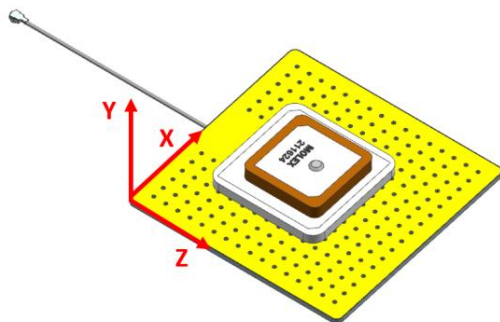


**FIGURE 4.7.2 AXIAL RATIO OF ANTENNA AT GPS L1+GLONASS L1 BAND IN FREE SPACE**

REVISION: <b>A</b>	ECR/ECN INFORMATION: EC No: 609778 DATE: 2019/03/07	TITLE: <b>GPS L1/L5 &amp; Glonass 36mm Stacked Patch Sing Feed Application Specification</b>	SHEET No. <b>10 of 36</b>
DOCUMENT NUMBER: <b>AS-2116240001</b>	CREATED / REVISED BY: Liu Hai 2019/03/05	CHECKED BY: Cheng Kang 2019/03/05	APPROVED BY: Andy Zhang 2019/03/05

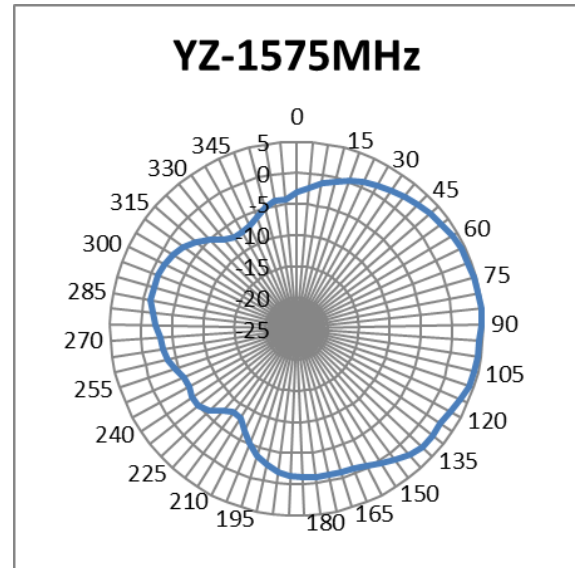
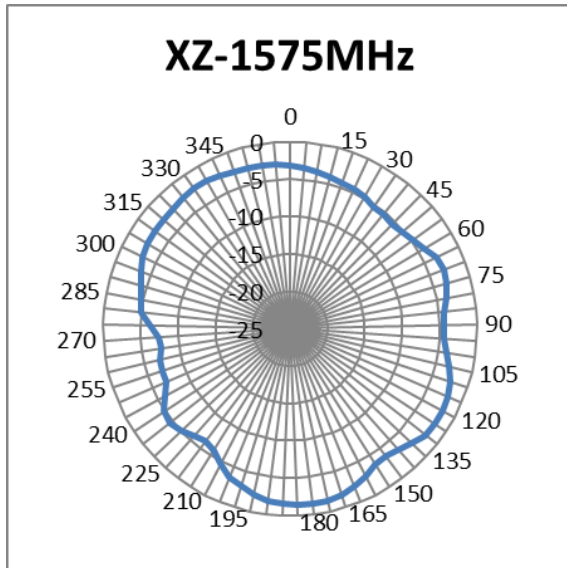
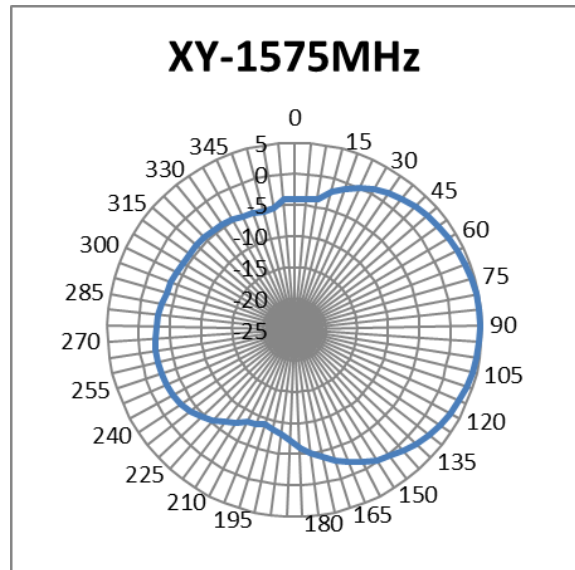
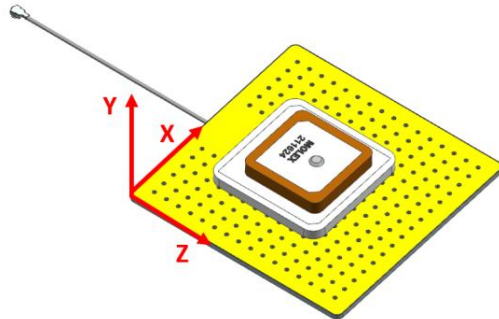
## 4.8 RADIATION PATTERN

All measurements in this document are done on the reference PCB.



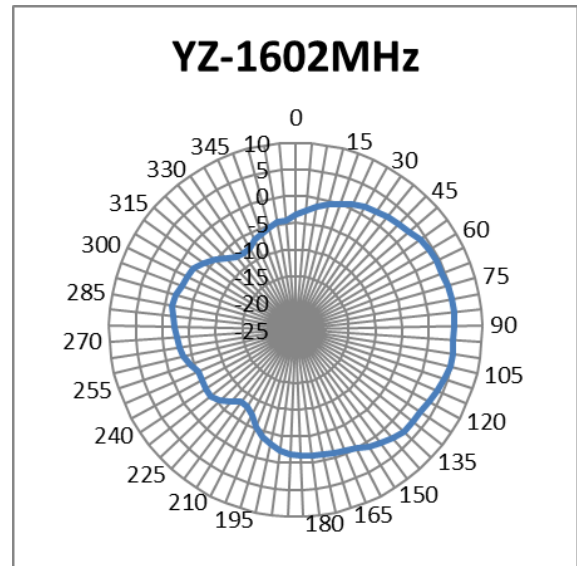
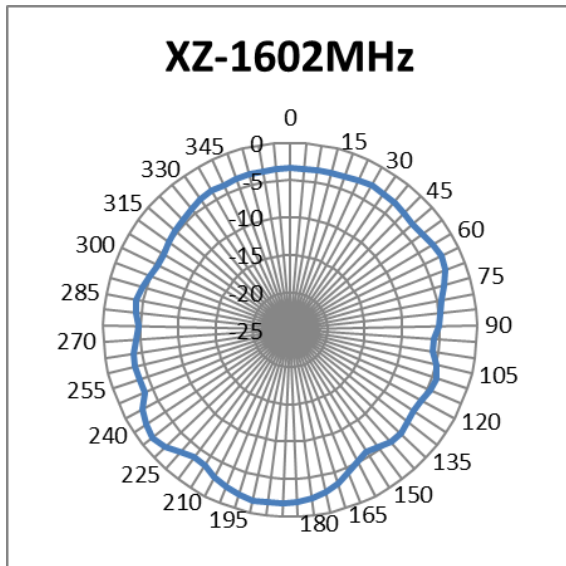
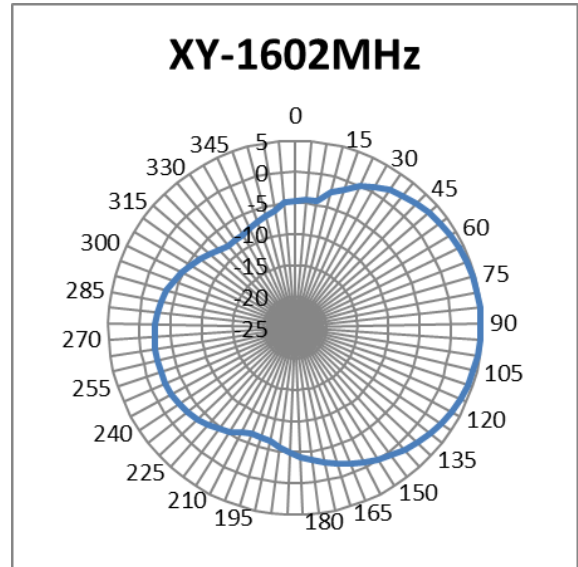
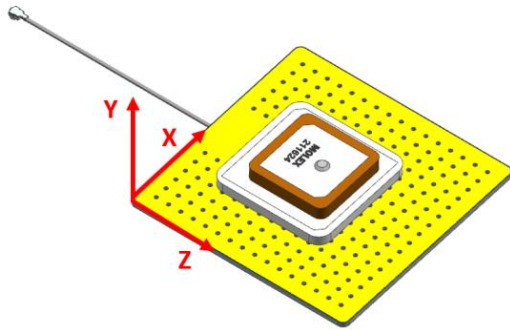
**FIGURE 4.8.1 2D RADIATION PATTERN OF ANTENNA AT 1176MHZ IN FREE SPACE**

REVISION: <b>A</b>	ECR/ECN INFORMATION: EC No: 609778 DATE: 2019/03/07	TITLE: <b>GPS L1/L5 &amp; Glonass 36mm Stacked Patch Sing Feed Application Specification</b>	SHEET No. <b>11 of 36</b>
DOCUMENT NUMBER: <b>AS-2116240001</b>	CREATED / REVISED BY: Liu Hai 2019/03/05	CHECKED BY: Cheng Kang 2019/03/05	APPROVED BY: Andy Zhang 2019/03/05



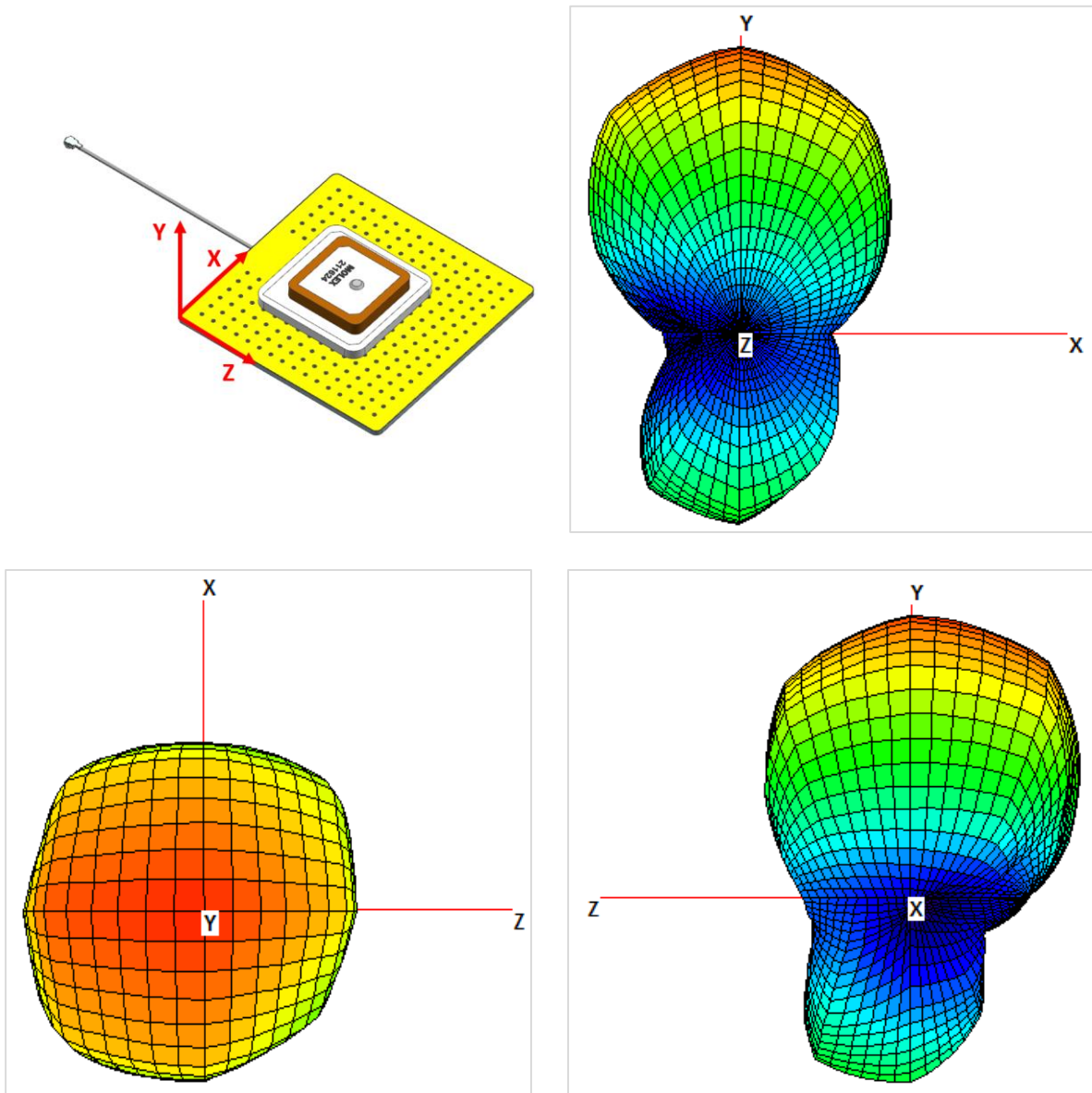
**FIGURE 4.8.2 2D RADIATION PATTERN OF ANTENNA AT 1575MHZ IN FREE SPACE**

REVISION: <b>A</b>	ECR/ECN INFORMATION: EC No: 609778 DATE: 2019/03/07	TITLE: <b>GPS L1/L5 &amp; Glonass 36mm Stacked Patch Sing Feed Application Specification</b>	SHEET No. <b>12 of 36</b>
DOCUMENT NUMBER: <b>AS-2116240001</b>	CREATED / REVISED BY: Liu Hai 2019/03/05	CHECKED BY: Cheng Kang 2019/03/05	APPROVED BY: Andy Zhang 2019/03/05



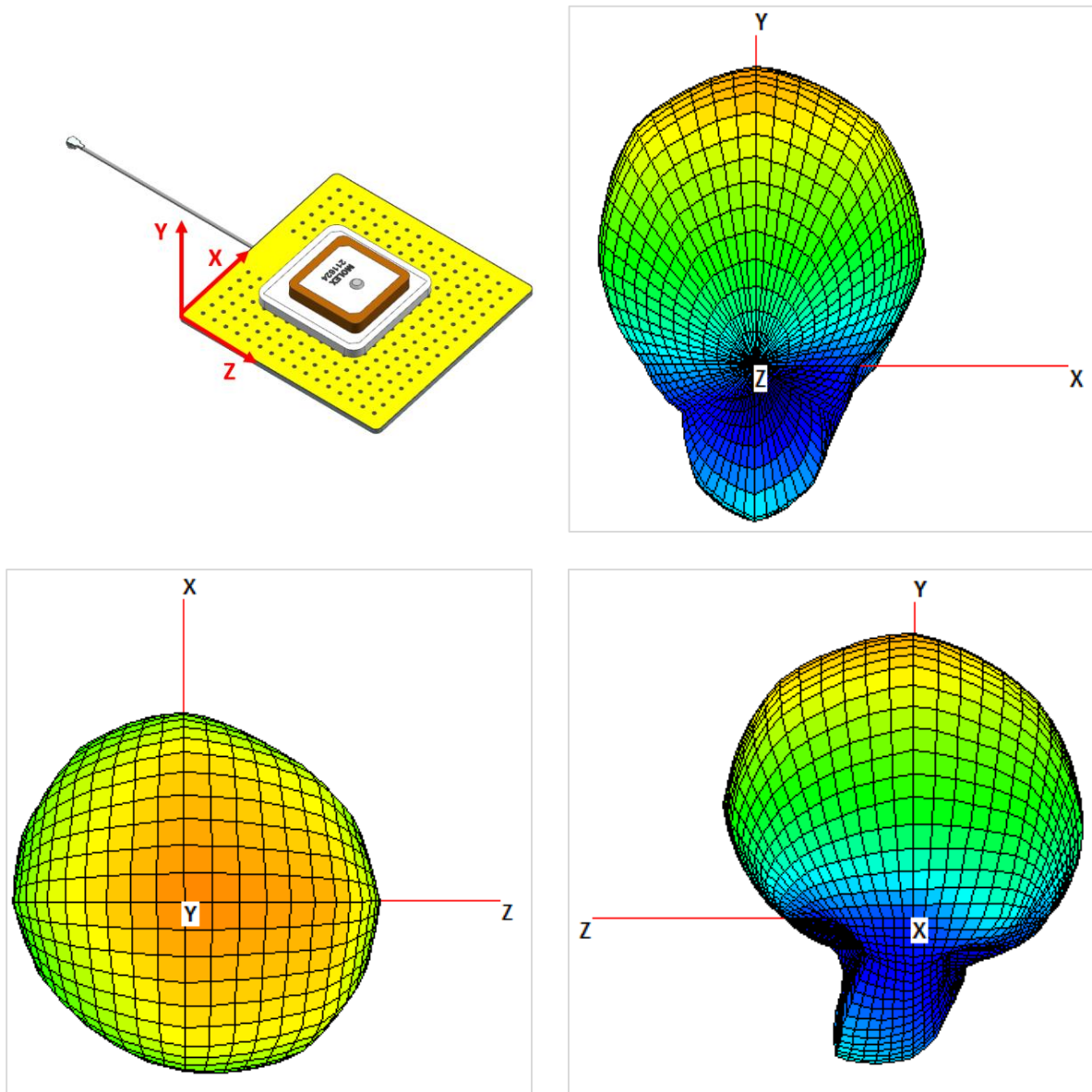
**FIGURE 4.8.3 2D RADIATION PATTERN OF ANTENNA AT 1602MHZ IN FREE SPACE**

REVISION: <b>A</b>	ECR/ECN INFORMATION: EC No: 609778 DATE: 2019/03/07	TITLE: <b>GPS L1/L5 &amp; Glonass 36mm Stacked Patch Sing Feed Application Specification</b>	SHEET No. <b>13 of 36</b>
DOCUMENT NUMBER: <b>AS-2116240001</b>	CREATED / REVISED BY: Liu Hai 2019/03/05	CHECKED BY: Cheng Kang 2019/03/05	APPROVED BY: Andy Zhang 2019/03/05



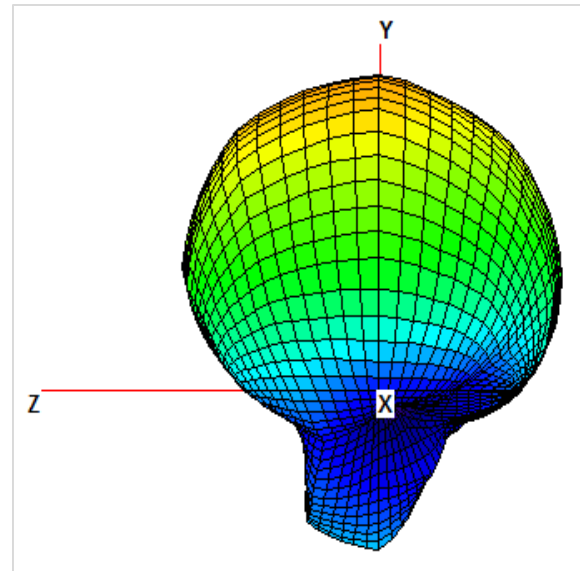
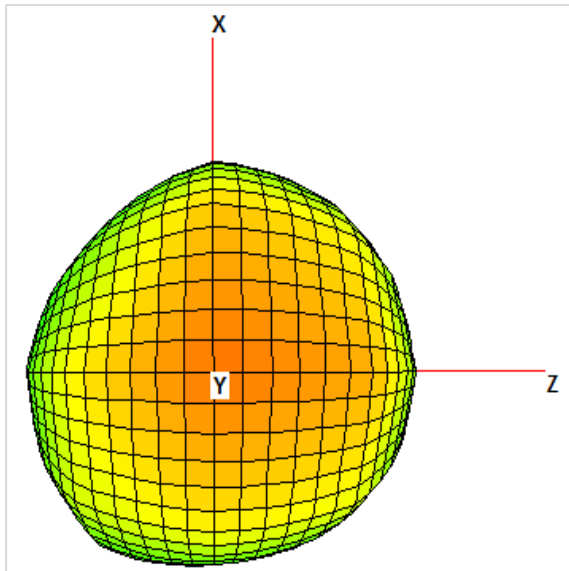
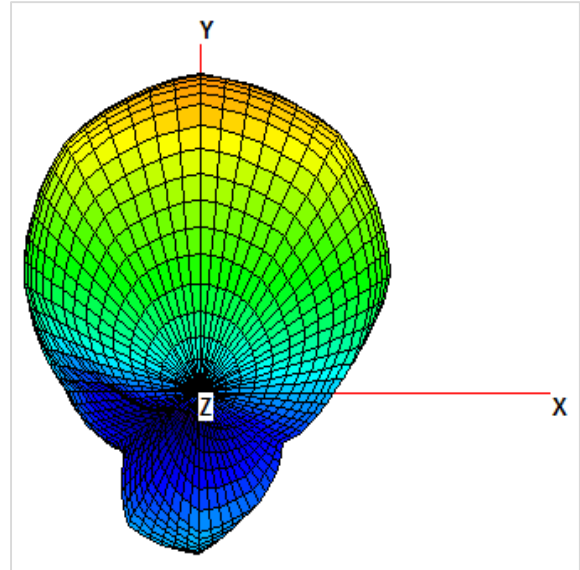
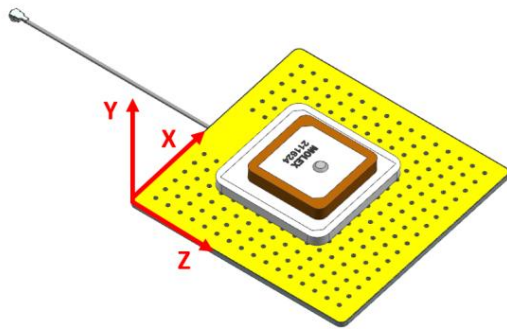
**FIGURE 4.8.4 3D RADIATION PATTERN OF ANTENNA AT 1176MHZ IN FREE SPACE**

REVISION: <b>A</b>	ECR/ECN INFORMATION: EC No: 609778 DATE: 2019/03/07	TITLE: <b>GPS L1/L5 &amp; Glonass 36mm Stacked Patch Sing Feed Application Specification</b>	SHEET No. <b>14 of 36</b>
DOCUMENT NUMBER: <b>AS-2116240001</b>	CREATED / REVISED BY: Liu Hai 2019/03/05	CHECKED BY: Cheng Kang 2019/03/05	APPROVED BY: Andy Zhang 2019/03/05



**FIGURE 4.8.5 3D RADIATION PATTERN OF ANTENNA AT 1575MHZ IN FREE SPACE**

REVISION:  <b>A</b>	ECR/ECN INFORMATION: EC No: 609778 DATE: 2019/03/07	TITLE:  <b>GPS L1/L5 &amp; Glonass 36mm Stacked Patch Sing Feed Application Specification</b>	SHEET No.  <b>15 of 36</b>
DOCUMENT NUMBER:  <b>AS-2116240001</b>	CREATED / REVISED BY: Liu Hai 2019/03/05	CHECKED BY: Cheng Kang 2019/03/05	APPROVED BY: Andy Zhang 2019/03/05



**FIGURE 4.8.6 3D RADIATION PATTERN OF ANTENNA AT 1602MHZ IN FREE SPACE**

REVISION: <b>A</b>	ECR/ECN INFORMATION: EC No: 609778 DATE: 2019/03/07	TITLE: <b>GPS L1/L5 &amp; Glonass 36mm Stacked Patch Sing Feed Application Specification</b>		SHEET No. <b>16 of 36</b>
DOCUMENT NUMBER: <b>AS-2116240001</b>		CREATED / REVISED BY: Liu Hai 2019/03/05	CHECKED BY: Cheng Kang 2019/03/05	APPROVED BY: Andy Zhang 2019/03/05

## 5.0 RF PERFORMANCE AS A FUNCTION OF IMPLEMENTATION

### 5.1 ANTENNA RF PERFORMANCES AS A FUNCTION OF DIFFERENT LOCATIONS ON THE GROUND PLANE

Three locations have been evaluated, and these configurations are shown in figure 5.1.0. The figures 5.1.1-5.1.8 show the return loss, the efficiency, the peak gain and axial ratio.

The location which gives the best RF performance is location 1. Location 1 (center location) is the recommended location for the antenna.

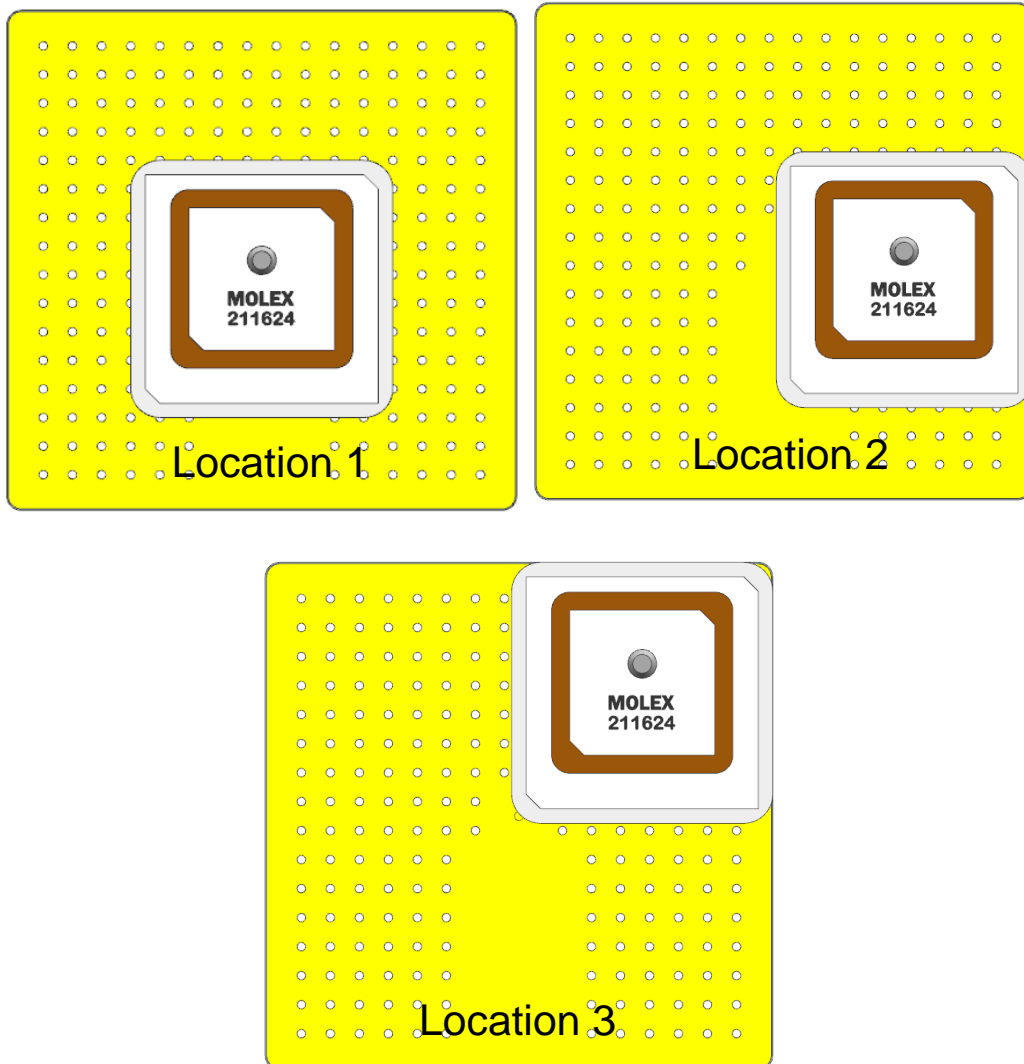
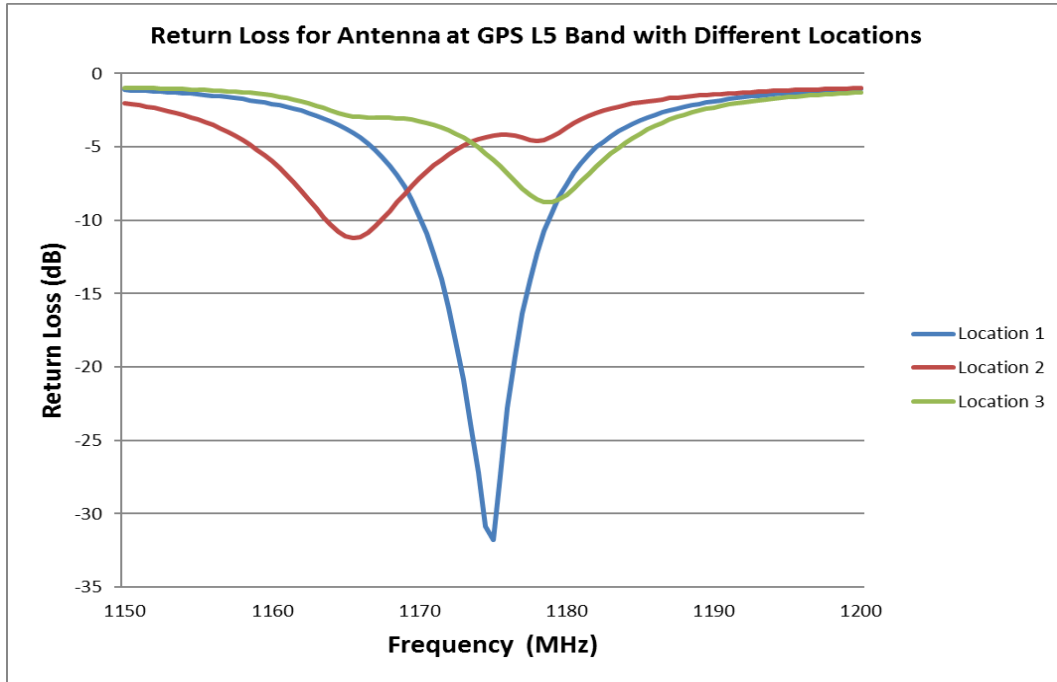
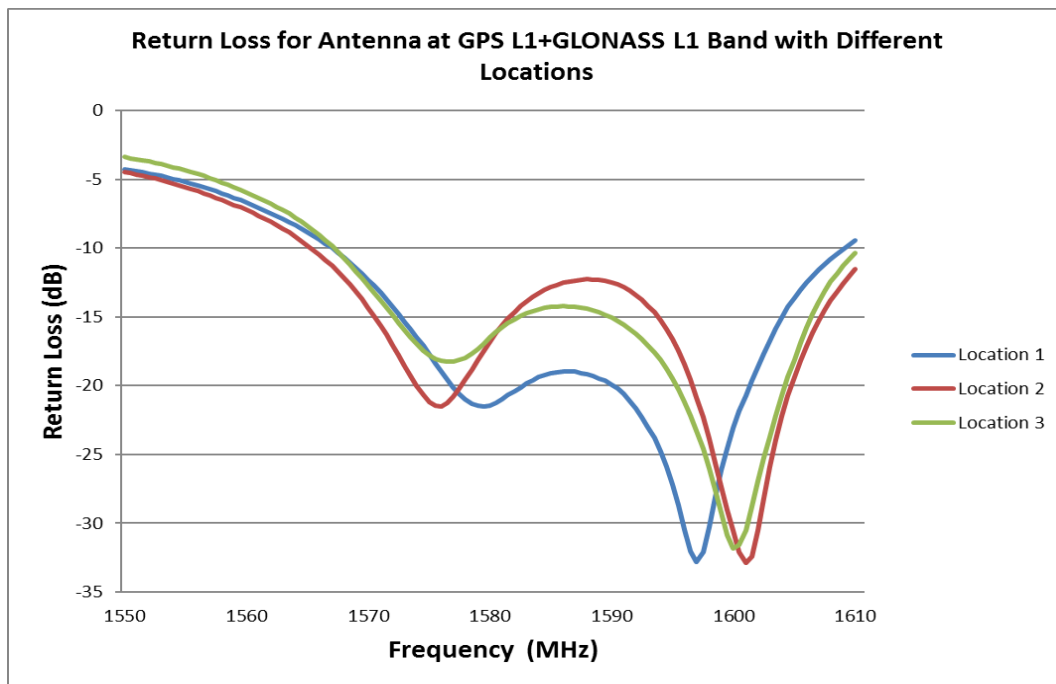


FIGURE 5.1.0 THREE LOCATIONS ON REFERENCE PCB

REVISION: <b>A</b>	ECR/ECN INFORMATION: EC No: 609778 DATE: 2019/03/07	TITLE: <b>GPS L1/L5 &amp; Glonass 36mm Stacked Patch Sing Feed Application Specification</b>	SHEET No. <b>17 of 36</b>
DOCUMENT NUMBER: <b>AS-2116240001</b>	CREATED / REVISED BY: Liu Hai 2019/03/05	CHECKED BY: Cheng Kang 2019/03/05	APPROVED BY: Andy Zhang 2019/03/05

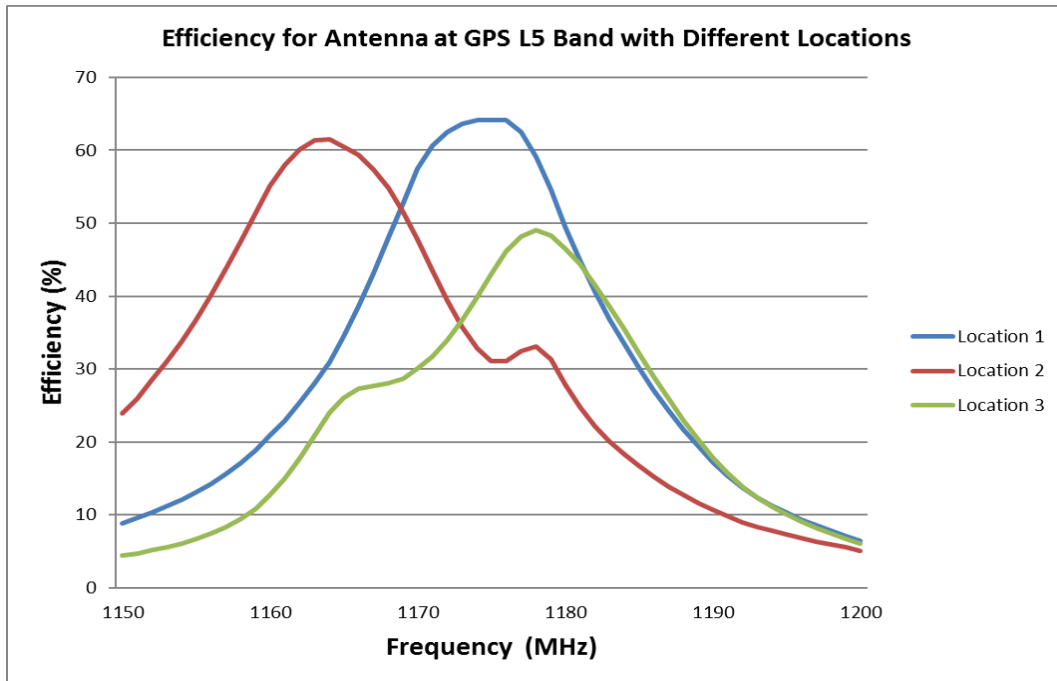


**FIGURE 5.1.1 RETURN LOSS OF ANTENNA AT GPS L5 BAND AT THREE LOCATIONS**

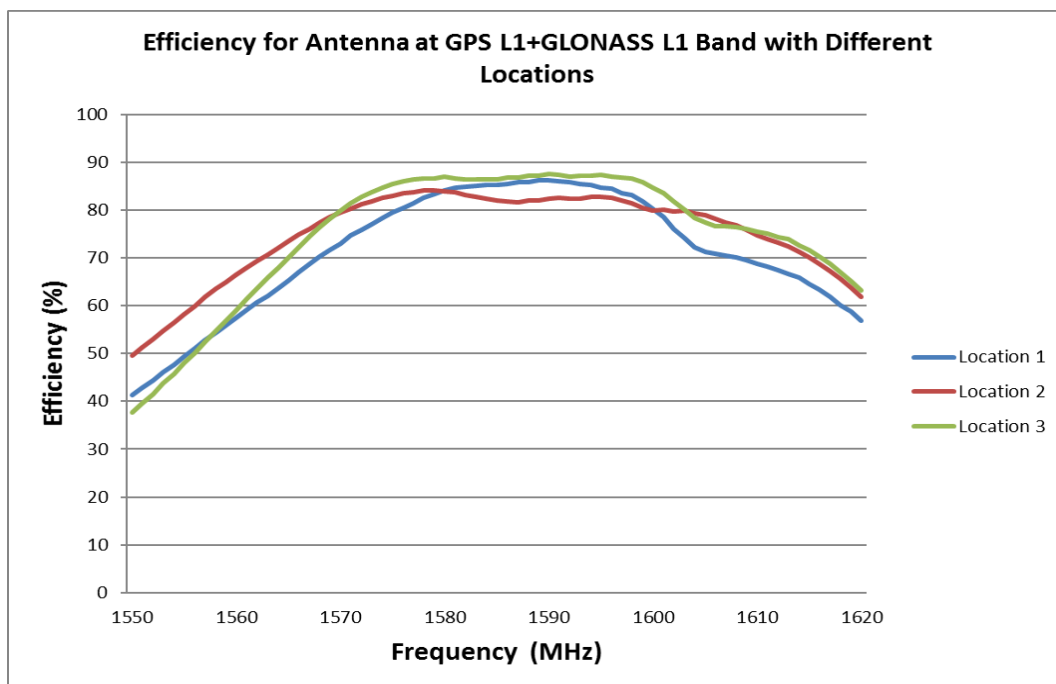


**FIGURE 5.1.2 RETURN LOSS OF ANTENNA AT GPS L1+GLONASS L1 BAND AT THREE LOCATIONS**

REVISION: <b>A</b>	ECR/ECN INFORMATION: EC No: 609778 DATE: 2019/03/07	TITLE: <b>GPS L1/L5 &amp; Glonass 36mm Stacked Patch Sing Feed Application Specification</b>	SHEET No. <b>18 of 36</b>
DOCUMENT NUMBER: <b>AS-2116240001</b>	CREATED / REVISED BY: Liu Hai 2019/03/05	CHECKED BY: Cheng Kang 2019/03/05	APPROVED BY: Andy Zhang 2019/03/05

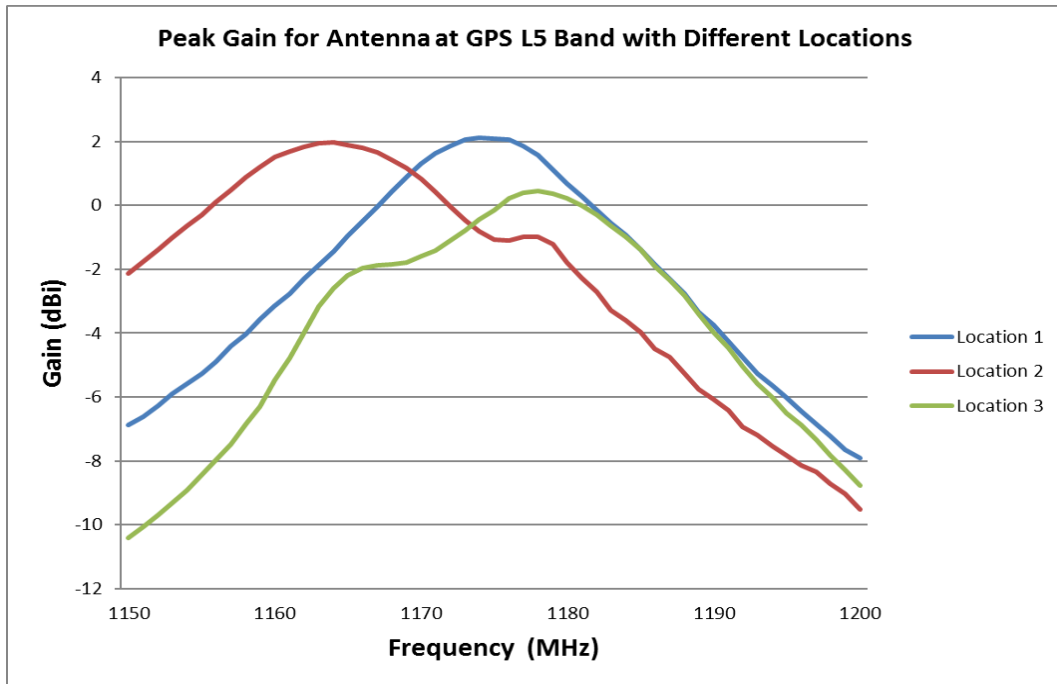


**FIGURE 5.1.3 EFFICIENCY OF ANTENNA AT GPS L5 BAND AT THREE LOCATIONS**

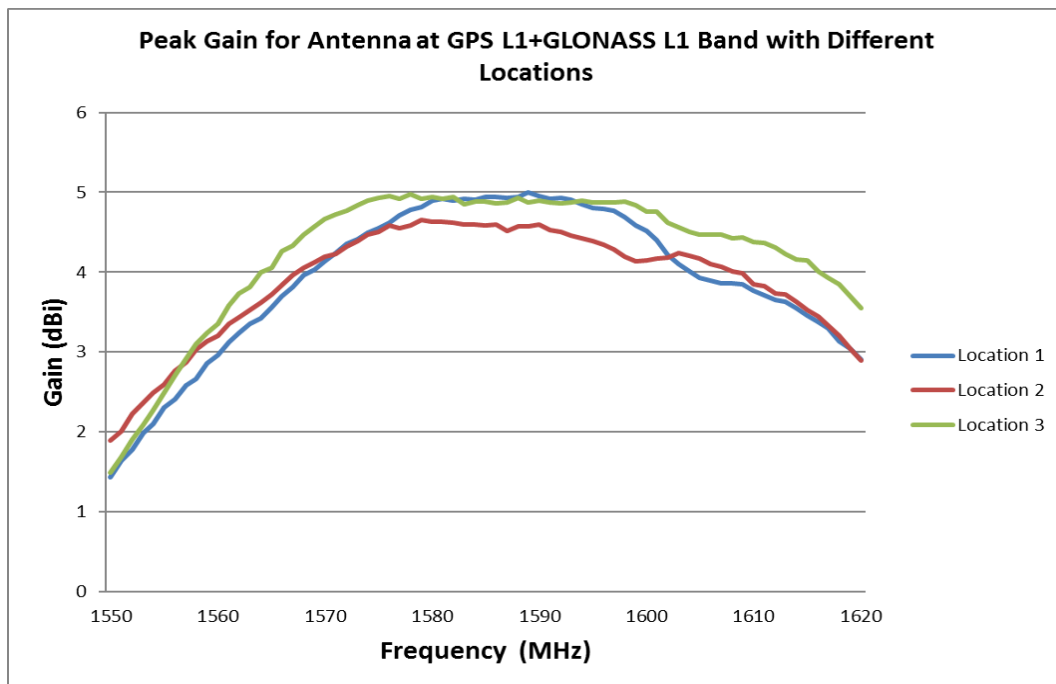


**FIGURE 5.1.4 EFFICIENCY OF ANTENNA AT GPS L1+GLONASS L1 BAND AT THREE LOCATIONS**

REVISION: <b>A</b>	ECR/ECN INFORMATION: EC No: 609778 DATE: 2019/03/07	TITLE: <b>GPS L1/L5 &amp; Glonass 36mm Stacked Patch Sing Feed Application Specification</b>	SHEET No. <b>19 of 36</b>
DOCUMENT NUMBER: <b>AS-2116240001</b>	CREATED / REVISED BY: Liu Hai 2019/03/05	CHECKED BY: Cheng Kang 2019/03/05	APPROVED BY: Andy Zhang 2019/03/05

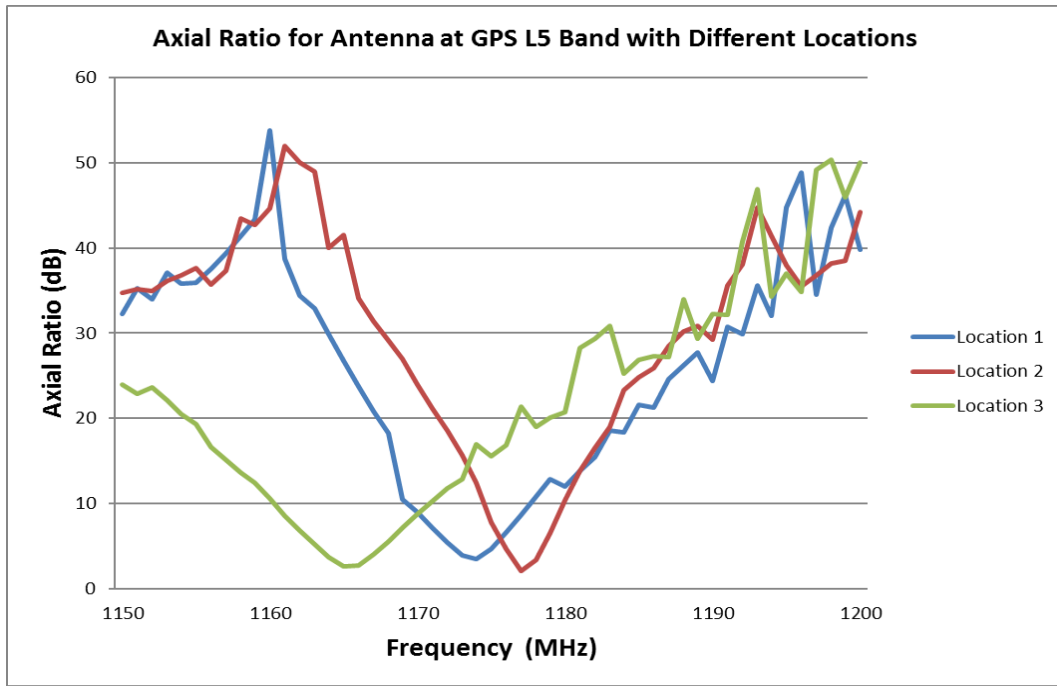


**FIGURE 5.1.5 PEAK GAIN OF ANTENNA AT GPS L5 BAND AT THREE LOCATIONS**

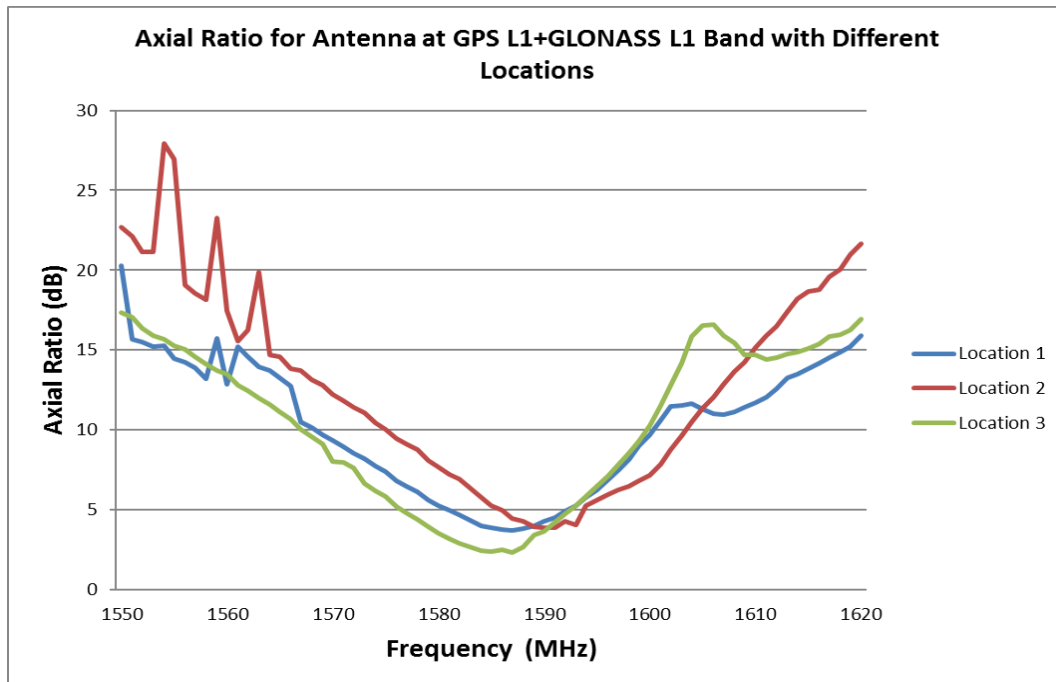


**FIGURE 5.1.6 PEAK GAIN OF ANTENNA AT GPS L1+GLONASS L1 BAND AT THREE LOCATIONS**

REVISION: <b>A</b>	ECR/ECN INFORMATION: EC No: 609778 DATE: 2019/03/07	TITLE: <b>GPS L1/L5 &amp; Glonass 36mm Stacked Patch Sing Feed Application Specification</b>	SHEET No. <b>20 of 36</b>
DOCUMENT NUMBER: <b>AS-2116240001</b>	CREATED / REVISED BY: Liu Hai 2019/03/05	CHECKED BY: Cheng Kang 2019/03/05	APPROVED BY: Andy Zhang 2019/03/05



**FIGURE 5.1.7 AXIAL RATIO OF ANTENNA AT GPS L5 BAND AT THREE LOCATIONS**

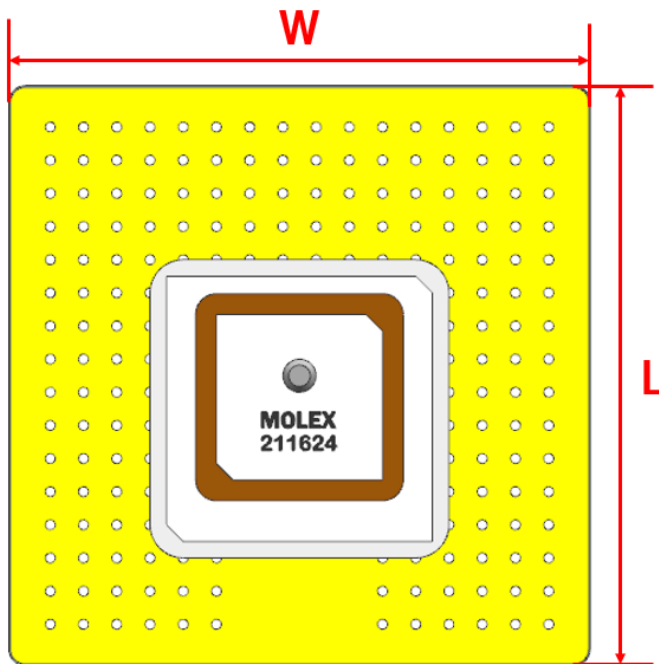


**FIGURE 5.1.8 AXIAL RATIO OF ANTENNA AT GPS L1+GLONASS L1 BAND AT THREE LOCATIONS**

REVISION: <b>A</b>	ECR/ECN INFORMATION: EC No: 609778 DATE: 2019/03/07	TITLE: <b>GPS L1/L5 &amp; Glonass 36mm Stacked Patch Sing Feed Application Specification</b>	SHEET No. <b>21 of 36</b>
DOCUMENT NUMBER: <b>AS-2116240001</b>	CREATED / REVISED BY: Liu Hai 2019/03/05	CHECKED BY: Cheng Kang 2019/03/05	APPROVED BY: Andy Zhang 2019/03/05

## 5.2 ANTENNA RF PERFORMANCES AS A FUNCTION OF DIFFERENT SIZED GROUNDS

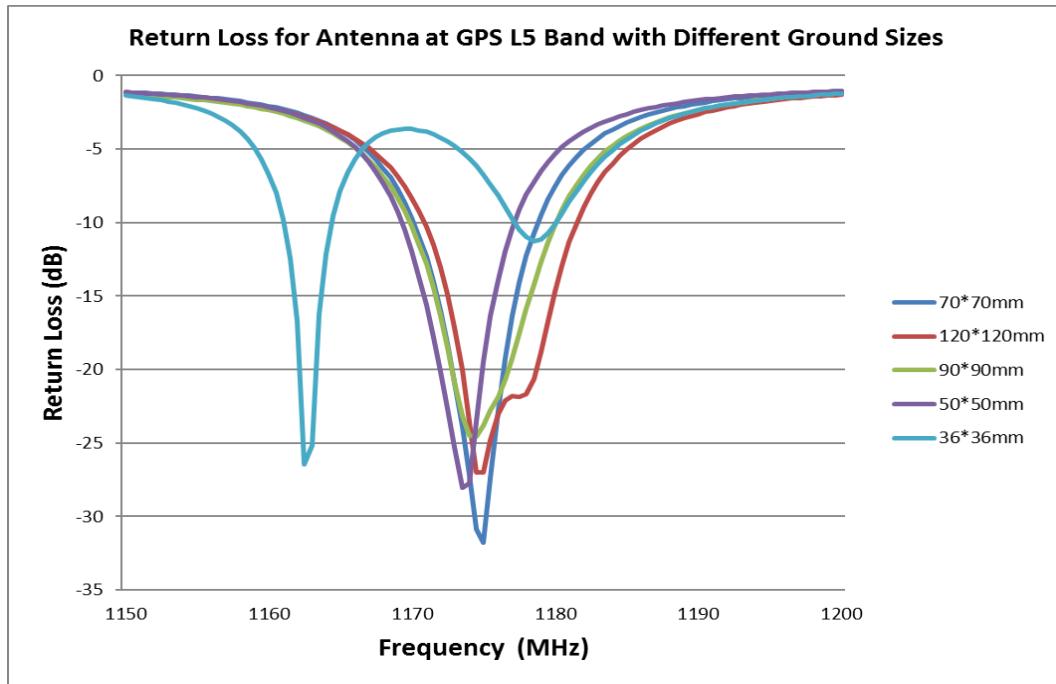
5 kinds of ground plane size have been evaluated, and these configurations are shown in figure 5.2.0. The figures 5.2.1-5.2.8 show the return loss, the efficiency, the peak gain and axial ratio. The ground plane size for this antenna is recommended to be 70mm\*70mm (reference size) to meet the antenna specification.



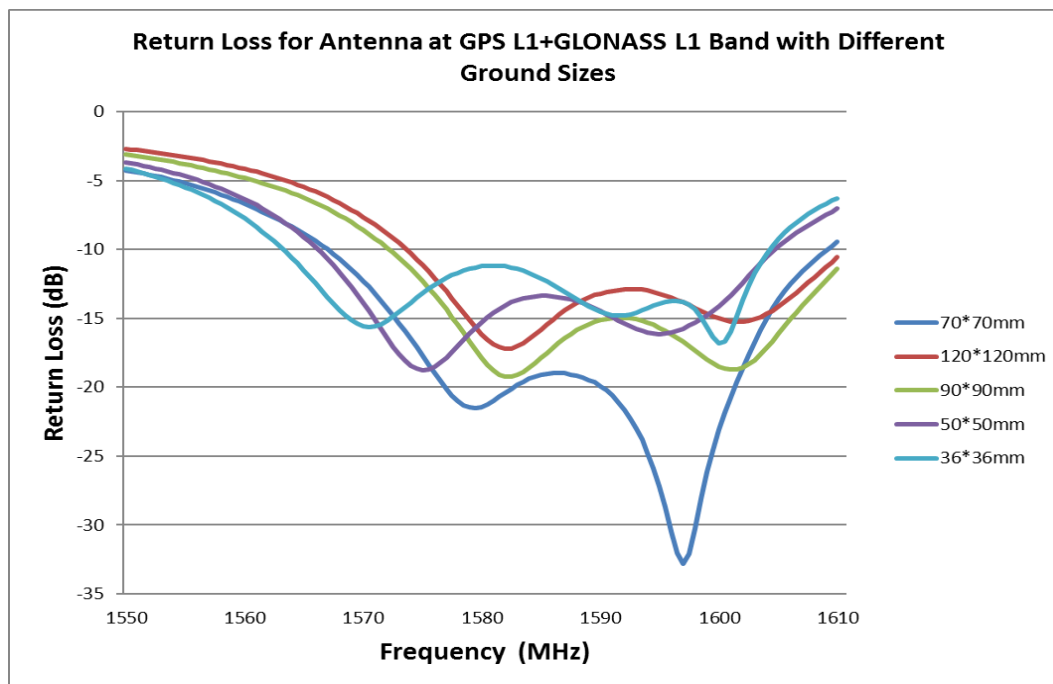
(W\*L: 36mm\*36mm, 50mm\*50mm, 70mm\*70mm, 90mm\*90mm, 120mm\*120mm)

**FIGURE 5.2.0 FIVE KINDS OF GROUND PLANE SIZE**

REVISION: <b>A</b>	ECR/ECN INFORMATION: EC No: 609778 DATE: 2019/03/07	TITLE: <b>GPS L1/L5 &amp; Glonass 36mm Stacked Patch Sing Feed Application Specification</b>	SHEET No. <b>22 of 36</b>
DOCUMENT NUMBER: <b>AS-2116240001</b>	CREATED / REVISED BY: Liu Hai 2019/03/05	CHECKED BY: Cheng Kang 2019/03/05	APPROVED BY: Andy Zhang 2019/03/05

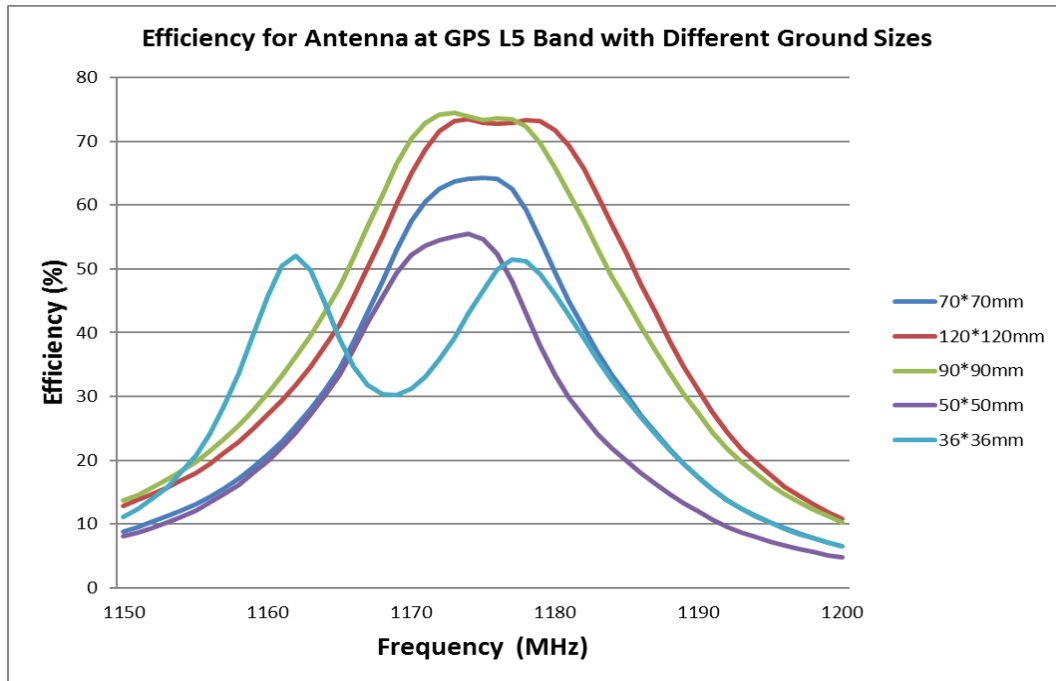


**FIGURE 5.2.1 RETURN LOSS OF ANTENNA AT GPS L5 BAND WITH DIFFERENT GROUND SIZES**

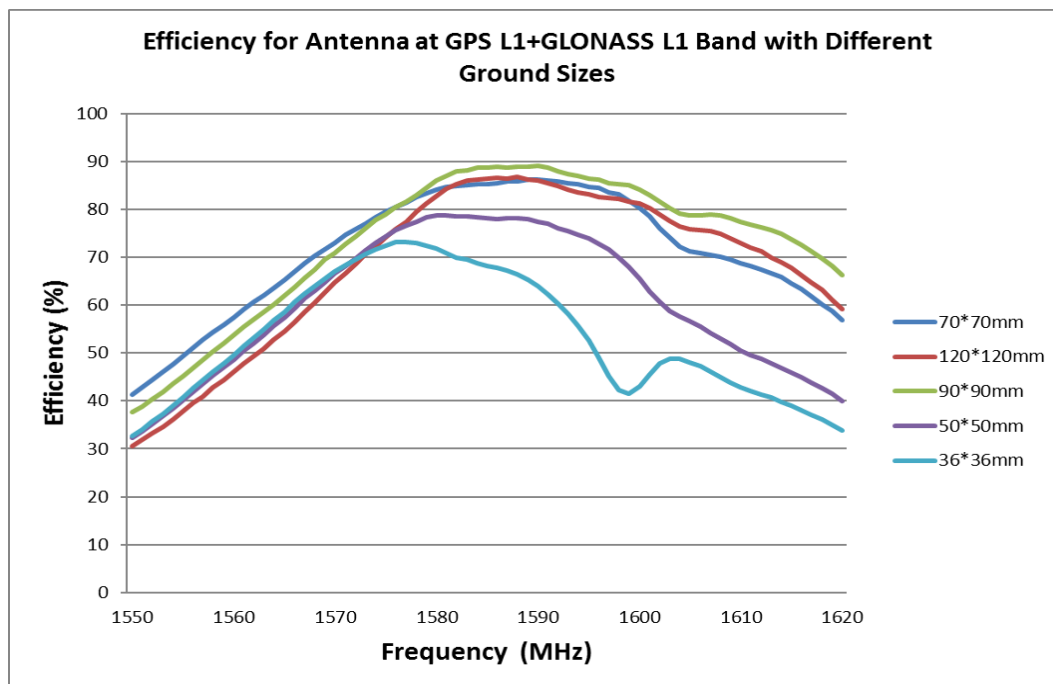


**FIGURE 5.2.2 RETURN LOSS OF ANTENNA AT GPS L1+GLONASS L1 BAND WITH DIFFERENT GROUND SIZES**

REVISION: <b>A</b>	ECR/ECN INFORMATION: EC No: 609778 DATE: 2019/03/07	TITLE: <b>GPS L1/L5 &amp; Glonass 36mm Stacked Patch Sing Feed Application Specification</b>	SHEET No. <b>23 of 36</b>
DOCUMENT NUMBER: <b>AS-2116240001</b>	CREATED / REVISED BY: Liu Hai 2019/03/05	CHECKED BY: Cheng Kang 2019/03/05	APPROVED BY: Andy Zhang 2019/03/05

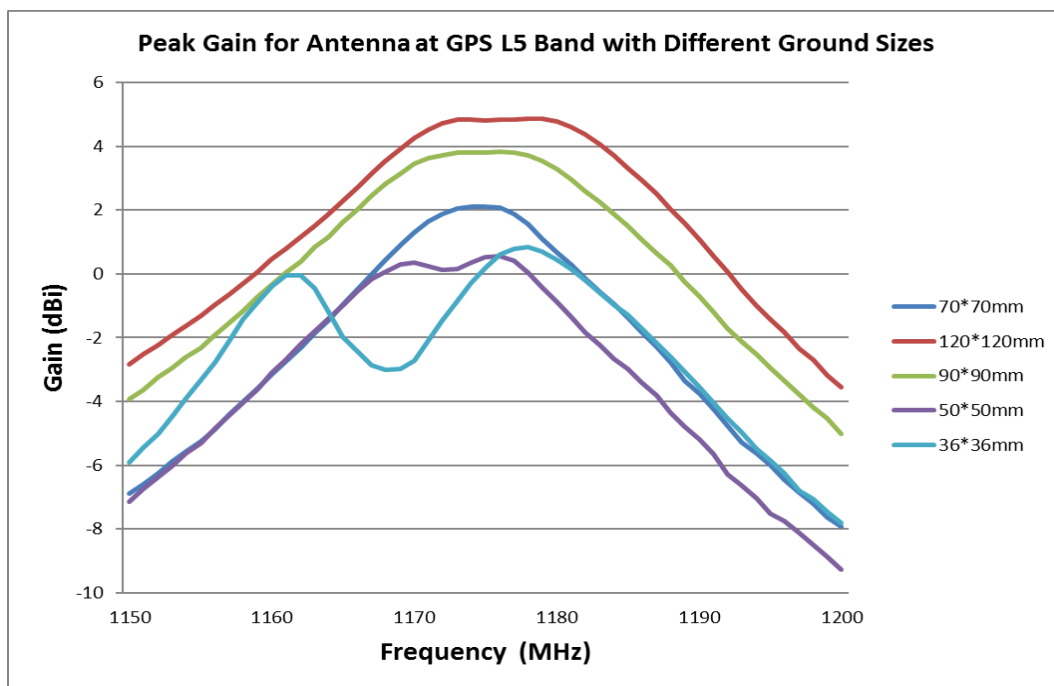


**FIGURE 5.2.3 EFFICIENCY OF ANTENNA AT GPS L5 BAND WITH DIFFERENT GROUND SIZES**

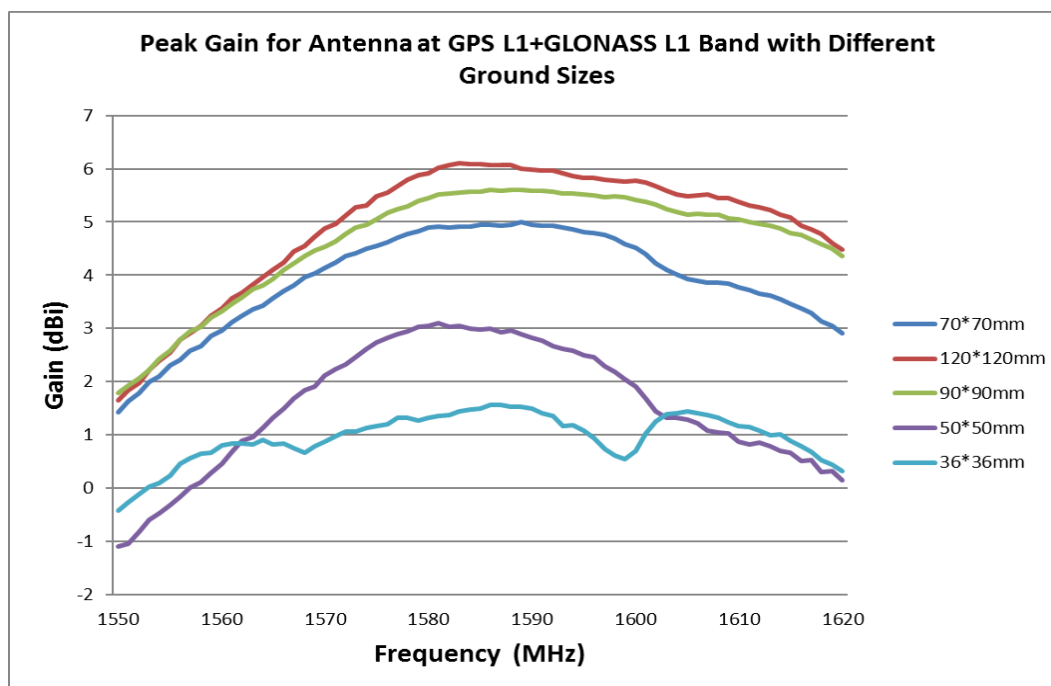


**FIGURE 5.2.4 EFFICIENCY OF ANTENNA AT GPS L1+GLONASS L1 BAND WITH DIFFERENT GROUND SIZES**

REVISION: <b>A</b>	ECR/ECN INFORMATION: EC No: 609778 DATE: 2019/03/07	TITLE: <b>GPS L1/L5 &amp; Glonass 36mm Stacked Patch Sing Feed Application Specification</b>	SHEET No. <b>24 of 36</b>
DOCUMENT NUMBER: <b>AS-2116240001</b>	CREATED / REVISED BY: Liu Hai 2019/03/05	CHECKED BY: Cheng Kang 2019/03/05	APPROVED BY: Andy Zhang 2019/03/05

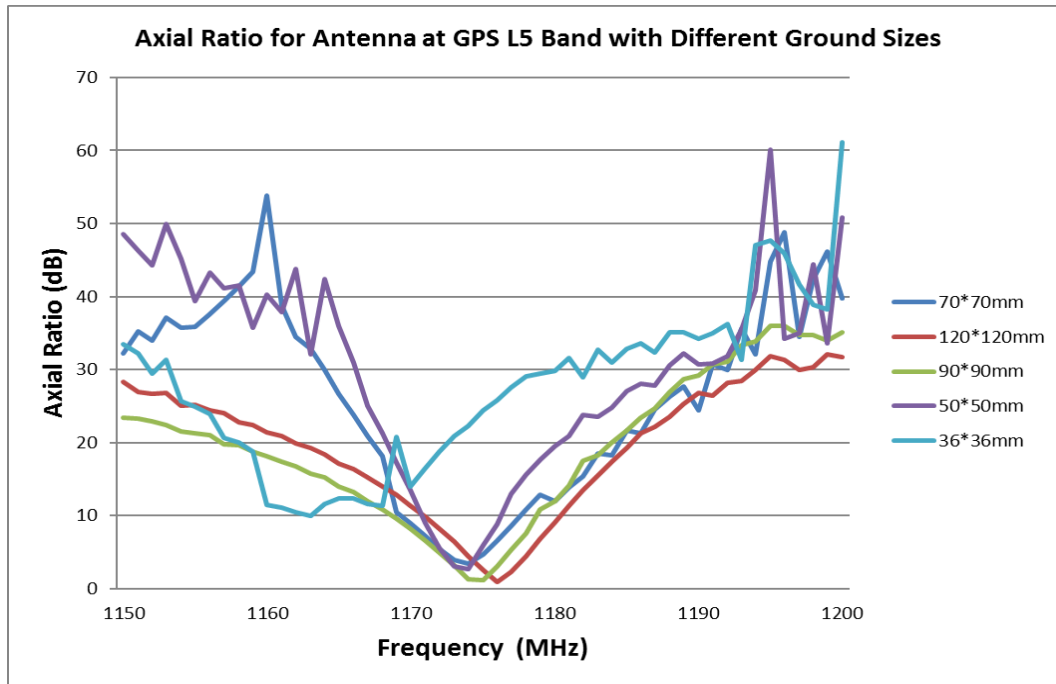


**FIGURE 5.2.5 PEAK GAIN OF ANTENNA AT GPS L5 BAND WITH DIFFERENT GROUND SIZES**

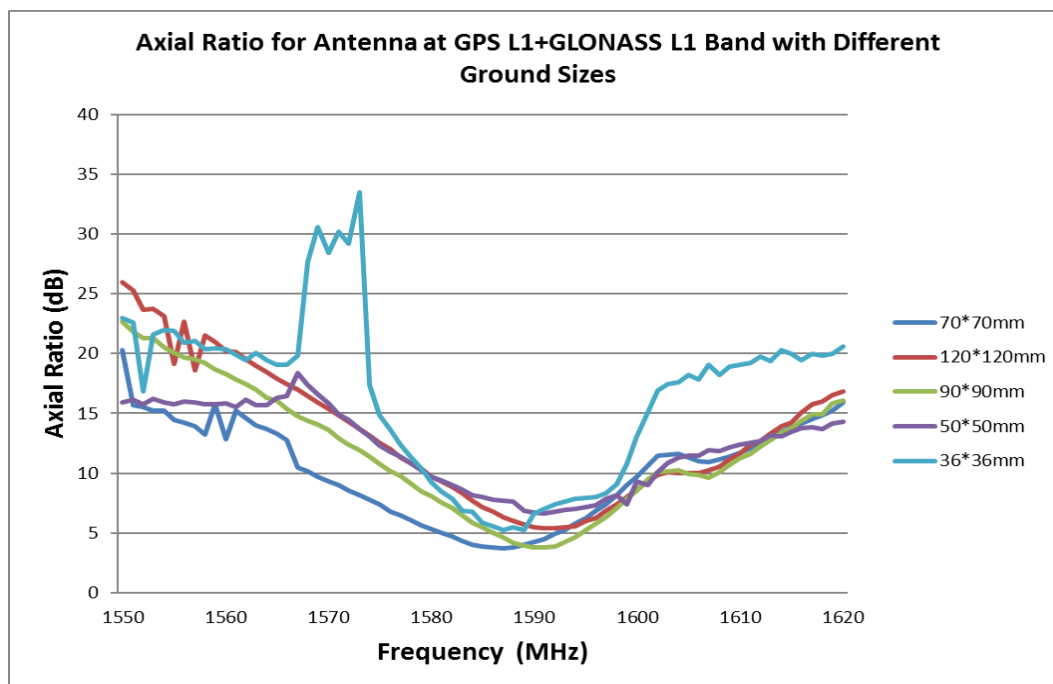


**FIGURE 5.2.6 PEAK GAIN OF ANTENNA AT GPS L1+GLONASS L1 BAND WITH DIFFERENT GROUND SIZES**

REVISION: <b>A</b>	ECR/ECN INFORMATION: EC No: 609778 DATE: 2019/03/07	TITLE: <b>GPS L1/L5 &amp; Glonass 36mm Stacked Patch Sing Feed Application Specification</b>	SHEET No. <b>25 of 36</b>
DOCUMENT NUMBER: <b>AS-2116240001</b>	CREATED / REVISED BY: Liu Hai 2019/03/05	CHECKED BY: Cheng Kang 2019/03/05	APPROVED BY: Andy Zhang 2019/03/05



**FIGURE 5.2.7 AXIAL RATIO OF ANTENNA AT GPS L5 BAND WITH DIFFERENT GROUND SIZES**



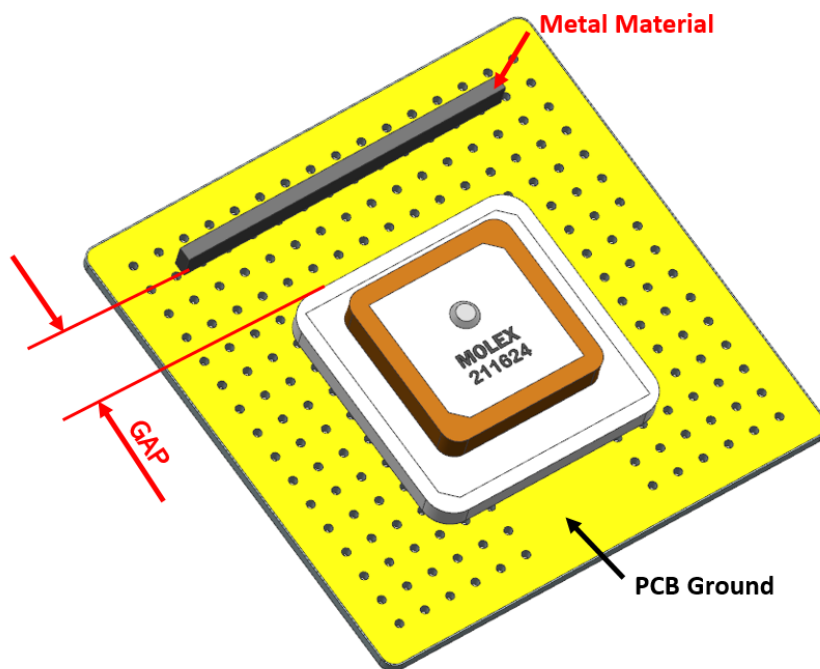
**FIGURE 5.2.8 AXIAL RATIO OF ANTENNA AT GPS L1+GLONASS L1 BAND WITH DIFFERENT GROUND SIZES**

REVISION:  <b>A</b>	ECR/ECN INFORMATION: EC No: 609778 DATE: 2019/03/07	TITLE:  <b>GPS L1/L5 &amp; Glonass 36mm Stacked Patch Sing Feed Application Specification</b>	SHEET No.  <b>26 of 36</b>
DOCUMENT NUMBER:  <b>AS-2116240001</b>	CREATED / REVISED BY: Liu Hai 2019/03/05	CHECKED BY: Cheng Kang 2019/03/05	APPROVED BY: Andy Zhang 2019/03/05

## 5.3 RF PERFORMANCE AS A FUNCTION OF DIFFERENT DISTANCE BETWEEN VERTICAL METAL MATERIAL AND ANTENNA

An evaluation was done with 5 different distances from the antenna which is located at the recommended location to the vertical metal material (50mm x 4mm x 2mm). The 5 distances are as following: 1mm, 3mm, 5mm, 7mm, 10mm.

From the study, we recommend that a metal material (50mm x 4mm x 2mm) should be placed at least 3mm away from the antenna. When the distance is less than 3mm, the antenna performance will be significantly degraded. Refer to figure 5.3.1-5.3.8



**FIGURE 5.3.0 METAL MATERIAL FIXED ON REFERENCE PCB**

Metal Material Size: 50mm\*4mm\*2mm;

Location 1: Distance between antenna and metal material (GAP) ground is about 1 mm;

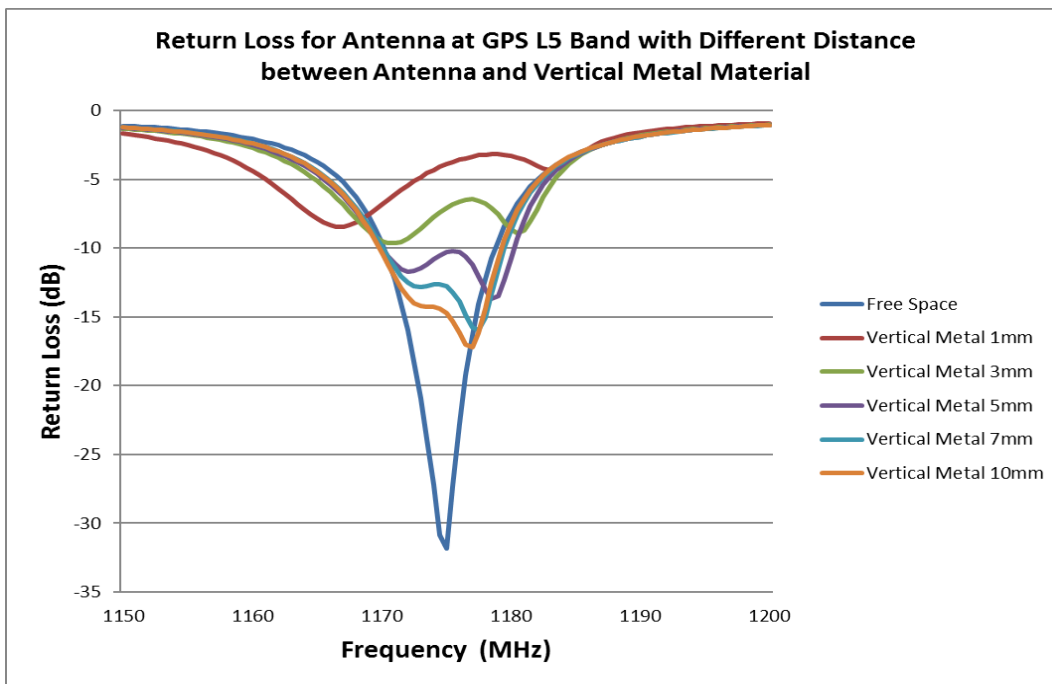
Location 2: Distance between antenna and metal material (GAP) ground is about 3 mm;

Location 3: Distance between antenna and metal material (GAP) ground is about 5 mm;

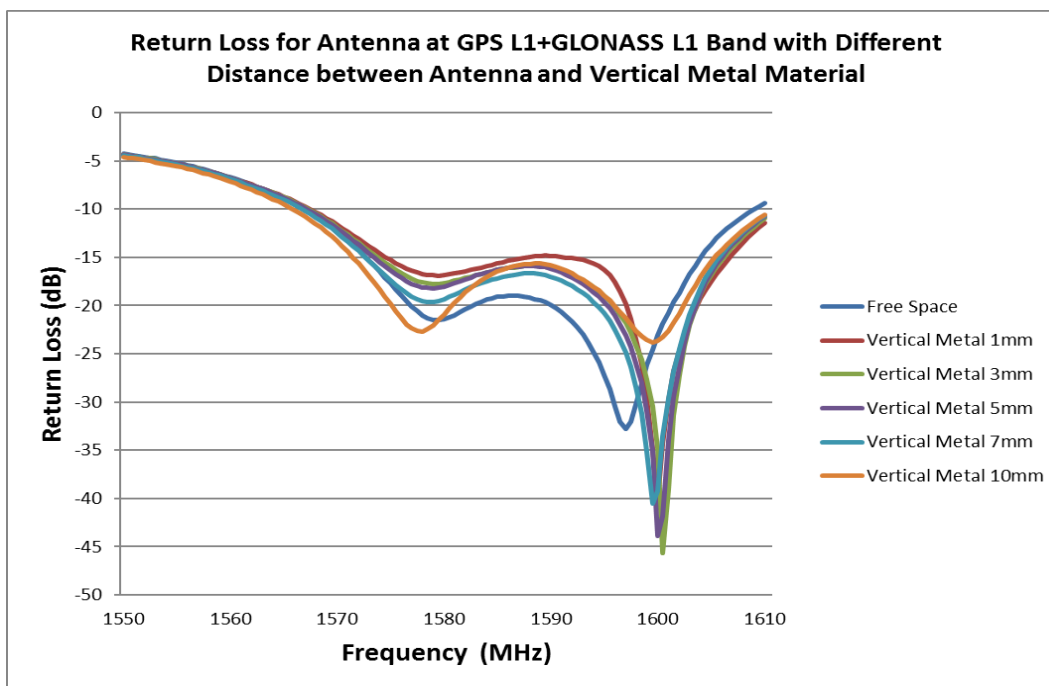
Location 4: Distance between antenna and metal material (GAP) ground is about 7 mm;

Location 5: Distance between antenna and metal material (GAP) ground is about 10 mm;

REVISION: <b>A</b>	ECR/ECN INFORMATION: EC No: 609778 DATE: 2019/03/07	TITLE: <b>GPS L1/L5 &amp; Glonass 36mm Stacked Patch Sing Feed Application Specification</b>	SHEET No. <b>27 of 36</b>
DOCUMENT NUMBER: <b>AS-2116240001</b>	CREATED / REVISED BY: Liu Hai 2019/03/05	CHECKED BY: Cheng Kang 2019/03/05	APPROVED BY: Andy Zhang 2019/03/05

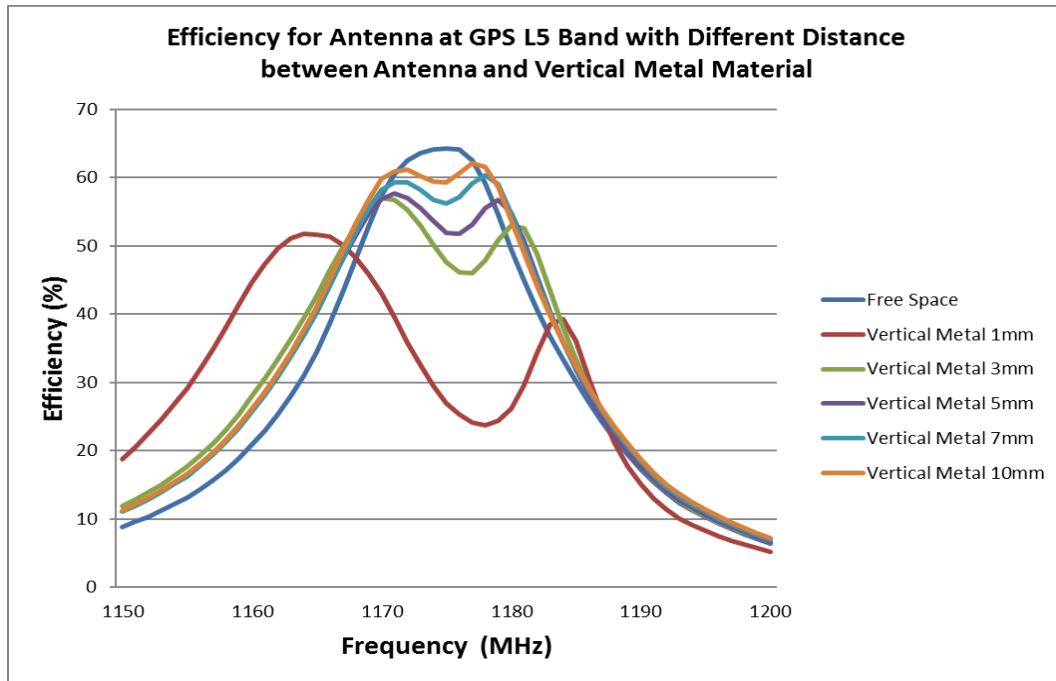


**FIGURE 5.3.1 RETURN LOSS OF ANTENNA AT GPS L5 BAND AT DIFFERENT DISTANCES BETWEEN ANTENNA AND VERTICAL METAL MATERIAL**

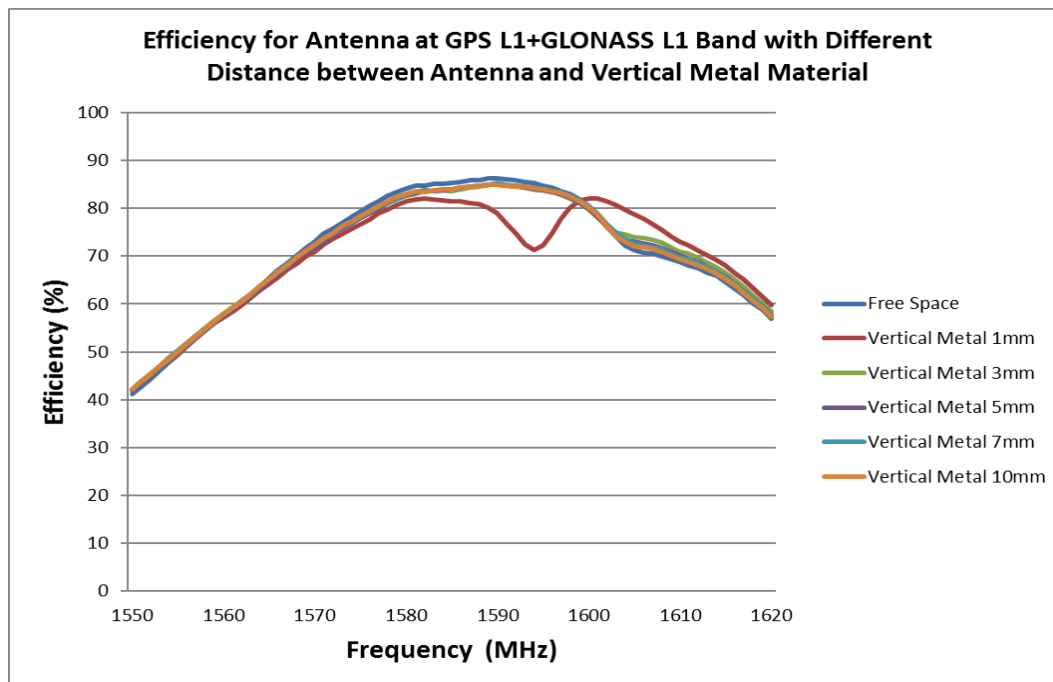


**FIGURE 5.3.2 RETURN LOSS OF ANTENNA AT GPS L1+GLONASS L1 BAND AT DIFFERENT DISTANCES BETWEEN ANTENNA AND VERTICAL METAL MATERIAL**

REVISION: <b>A</b>	ECR/ECN INFORMATION: EC No: 609778 DATE: 2019/03/07	TITLE: <b>GPS L1/L5 &amp; Glonass 36mm Stacked Patch Sing Feed Application Specification</b>	SHEET No. <b>28 of 36</b>
DOCUMENT NUMBER: <b>AS-2116240001</b>	CREATED / REVISED BY: Liu Hai 2019/03/05	CHECKED BY: Cheng Kang 2019/03/05	APPROVED BY: Andy Zhang 2019/03/05

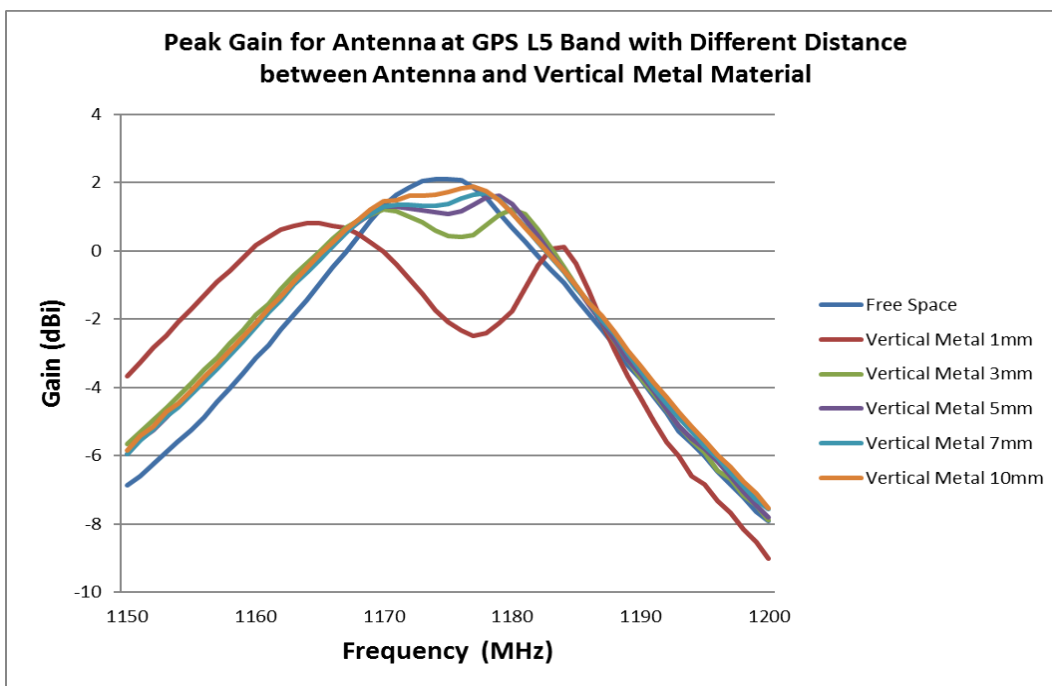


**FIGURE 5.3.3 EFFICIENCY OF ANTENNA AT GPS L5 BAND AT DIFFERENT DISTANCES BETWEEN ANTENNA AND VERTICAL METAL MATERIAL**

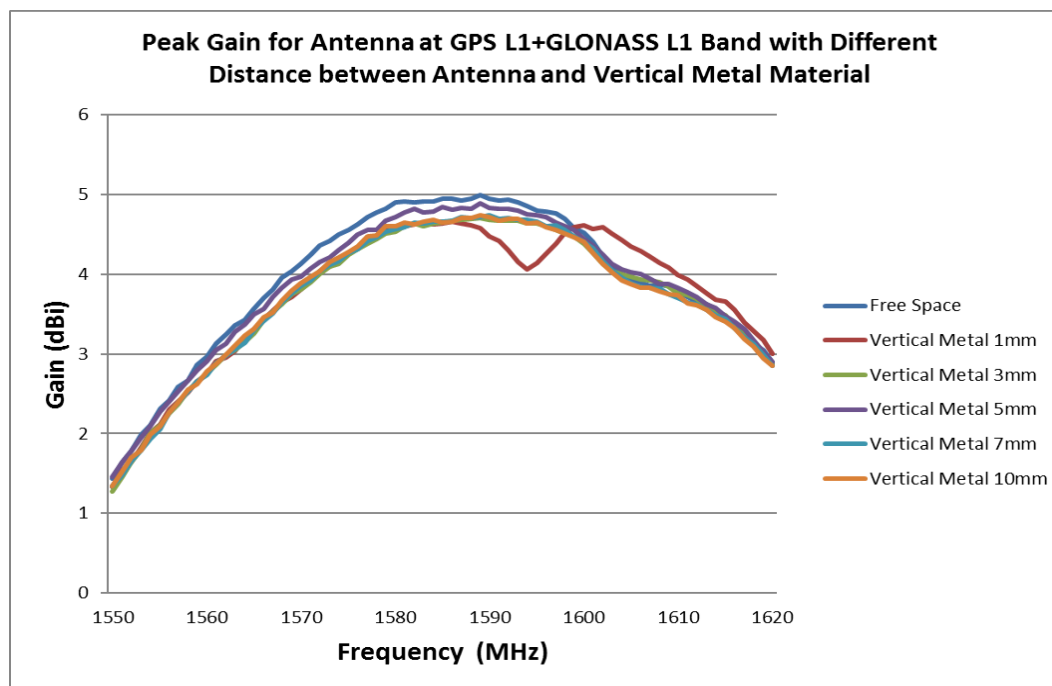


**FIGURE 5.3.4 EFFICIENCY OF ANTENNA AT GPS L1+GLONASS L1 BAND AT DIFFERENT DISTANCES BETWEEN ANTENNA AND VERTICAL METAL MATERIAL**

REVISION: <b>A</b>	ECR/ECN INFORMATION: EC No: 609778 DATE: 2019/03/07	TITLE: <b>GPS L1/L5 &amp; Glonass 36mm Stacked Patch Sing Feed Application Specification</b>	SHEET No. <b>29 of 36</b>
DOCUMENT NUMBER: <b>AS-2116240001</b>	CREATED / REVISED BY: Liu Hai 2019/03/05	CHECKED BY: Cheng Kang 2019/03/05	APPROVED BY: Andy Zhang 2019/03/05

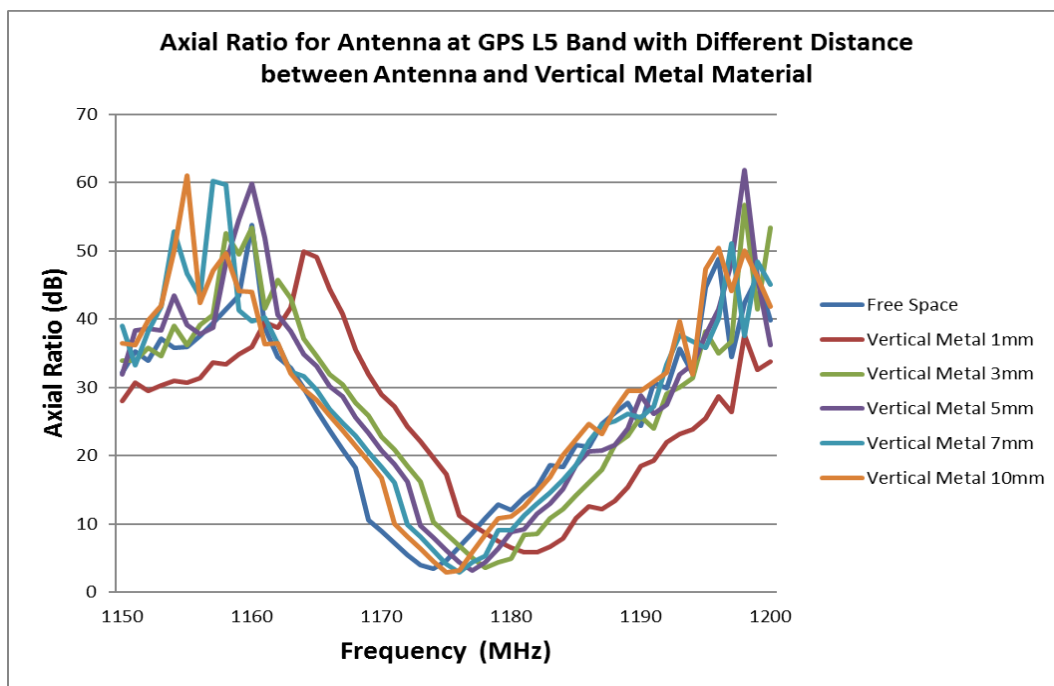


**FIGURE 5.3.5 PEAK GAIN OF ANTENNA AT GPS L5 BAND AT DIFFERENT DISTANCES BETWEEN ANTENNA AND VERTICAL METAL MATERIAL**

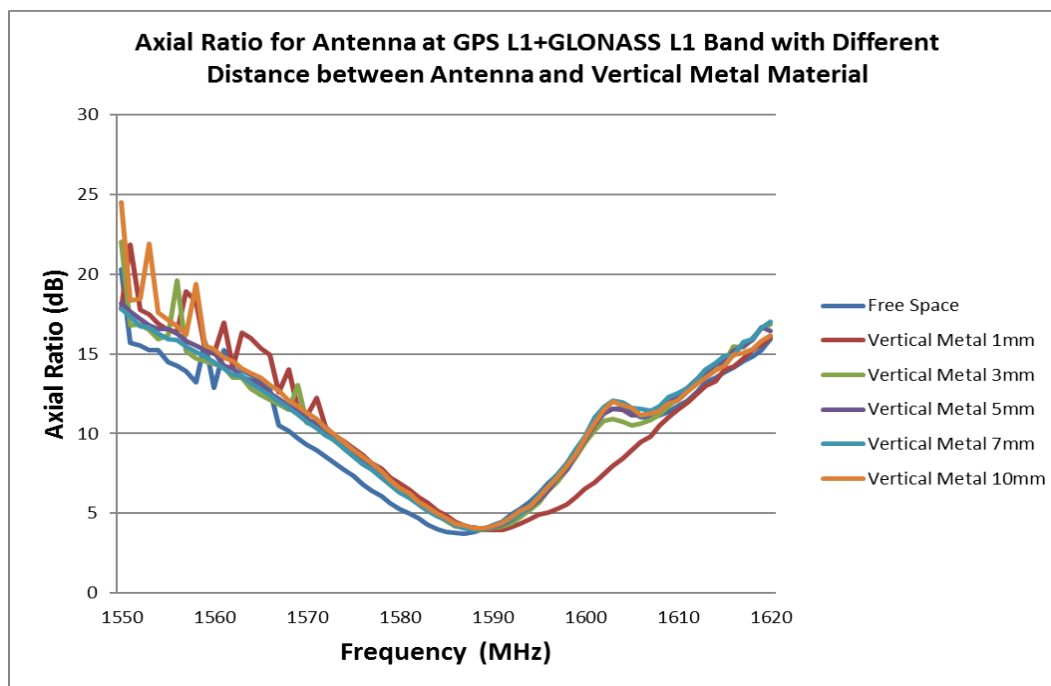


**FIGURE 5.3.6 PEAK GAIN OF ANTENNA AT GPS L1+GLONASS L1 BAND AT DIFFERENT DISTANCES BETWEEN ANTENNA AND VERTICAL METAL MATERIAL**

REVISION: <b>A</b>	ECR/ECN INFORMATION: EC No: 609778 DATE: 2019/03/07	TITLE: <b>GPS L1/L5 &amp; Glonass 36mm Stacked Patch Sing Feed Application Specification</b>	SHEET No. <b>30 of 36</b>
DOCUMENT NUMBER: <b>AS-2116240001</b>	CREATED / REVISED BY: Liu Hai 2019/03/05	CHECKED BY: Cheng Kang 2019/03/05	APPROVED BY: Andy Zhang 2019/03/05



**FIGURE 5.3.7 AXIAL RATIO OF ANTENNA AT GPS L5 BAND AT DIFFERENT DISTANCES BETWEEN ANTENNA AND VERTICAL METAL MATERIAL**



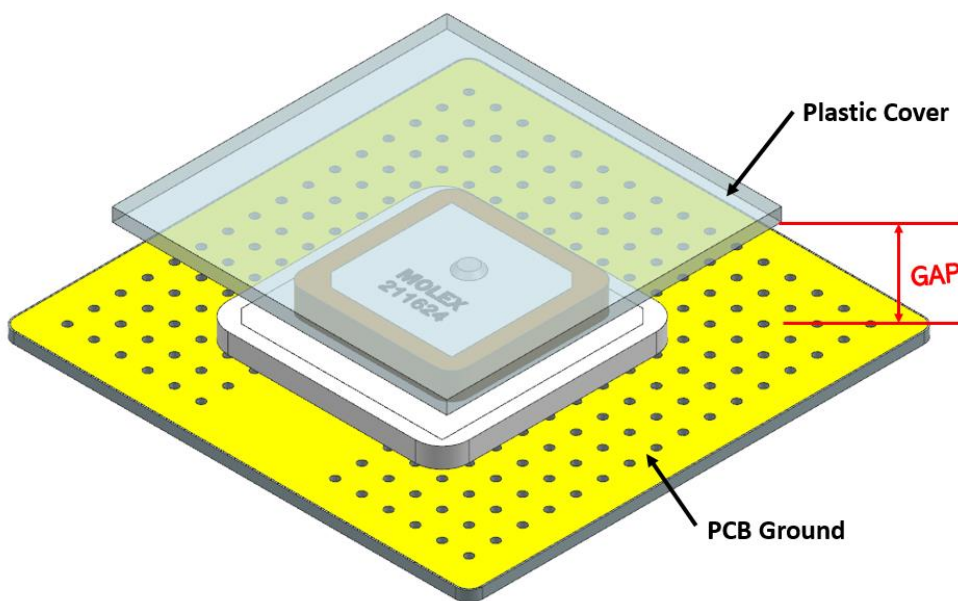
**FIGURE 5.3.8 AXIAL RATIO OF ANTENNA AT GPS L1+GLONASS L1 BAND AT DIFFERENT DISTANCES BETWEEN ANTENNA AND VERTICAL METAL MATERIAL**

REVISION: <b>A</b>	ECR/ECN INFORMATION: EC No: 609778 DATE: 2019/03/07	TITLE: <b>GPS L1/L5 &amp; Glonass 36mm Stacked Patch Sing Feed Application Specification</b>	SHEET No. <b>31 of 36</b>
DOCUMENT NUMBER: <b>AS-2116240001</b>	CREATED / REVISED BY: Liu Hai 2019/03/05	CHECKED BY: Cheng Kang 2019/03/05	APPROVED BY: Andy Zhang 2019/03/05

## 5.4 RF PERFORMANCE AS A FUNCTION OF DIFFERENT DISTANCE BETWEEN HORIZONTAL PLASTIC COVER AND ANTENNA

An evaluation was done with 5 different distances from antenna to the horizontal plastic cover (50mm x 50mm x 2mm). The 5 distances are as following: 0mm、 3mm、 5mm、 7mm、 10mm.

From the study, we recommend that a plastic cover (50mm x 50mm x 2mm) should be placed at least 3mm away from the antenna. When the distance is less than 3mm, the antenna performance will be significantly degraded. Refer to figure 5.4.1-5.4.8.



**FIGURE 6.4 PLASTIC COVER POSITIONS**

Plastic Cover Size: 50mm\*50mm\*2mm;

Location 1: Distance between PCB and plastic cover (GAP) ground is about 0 mm;

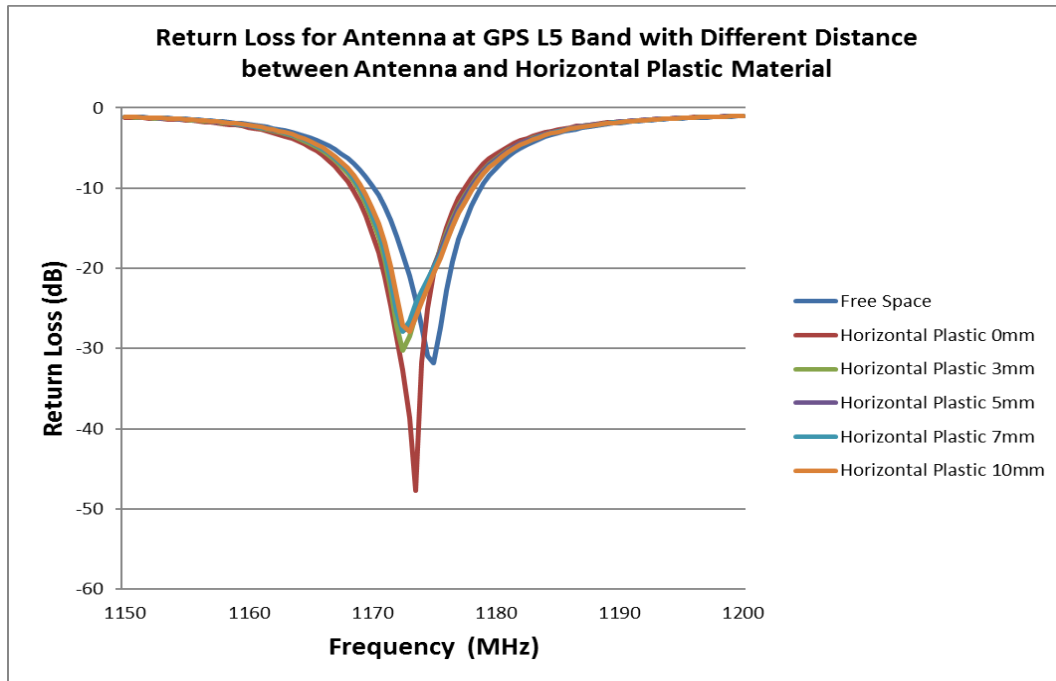
Location 2: Distance between PCB and plastic cover (GAP) ground is about 3 mm;

Location 3: Distance between PCB and plastic cover (GAP) ground is about 5 mm;

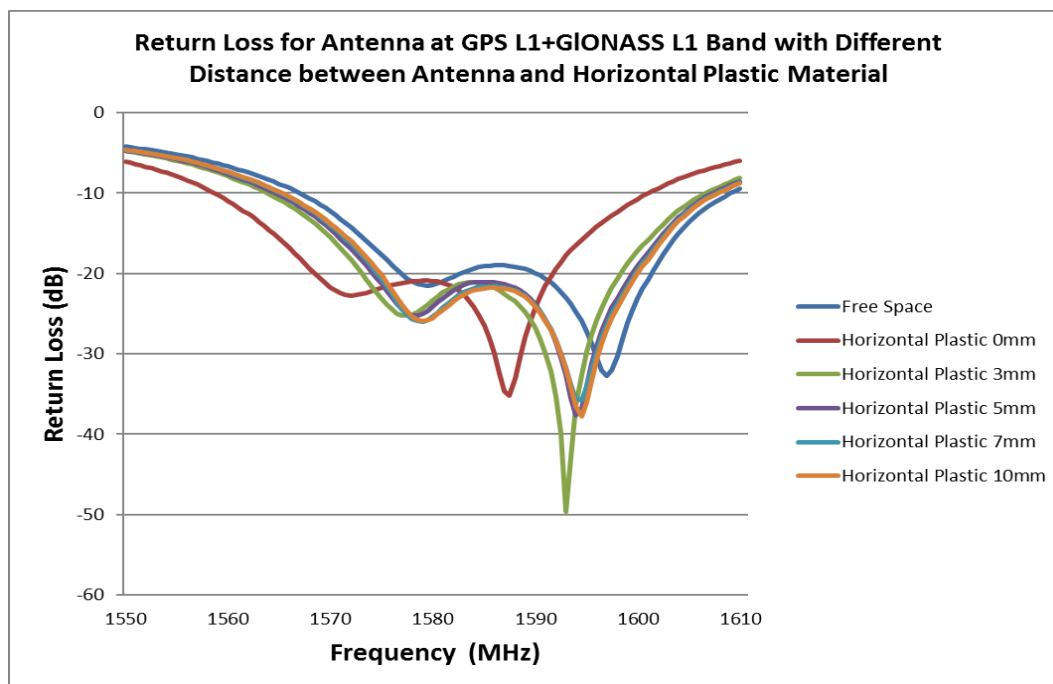
Location 4: Distance between PCB and plastic cover (GAP) ground is about 7 mm;

Location 5: Distance between PCB and plastic cover (GAP) ground is about 10 mm;

REVISION: <b>A</b>	ECR/ECN INFORMATION: EC No: 609778 DATE: 2019/03/07	TITLE: <b>GPS L1/L5 &amp; Glonass 36mm Stacked Patch Sing Feed Application Specification</b>	SHEET No. <b>32 of 36</b>
DOCUMENT NUMBER: <b>AS-2116240001</b>	CREATED / REVISED BY: Liu Hai 2019/03/05	CHECKED BY: Cheng Kang 2019/03/05	APPROVED BY: Andy Zhang 2019/03/05

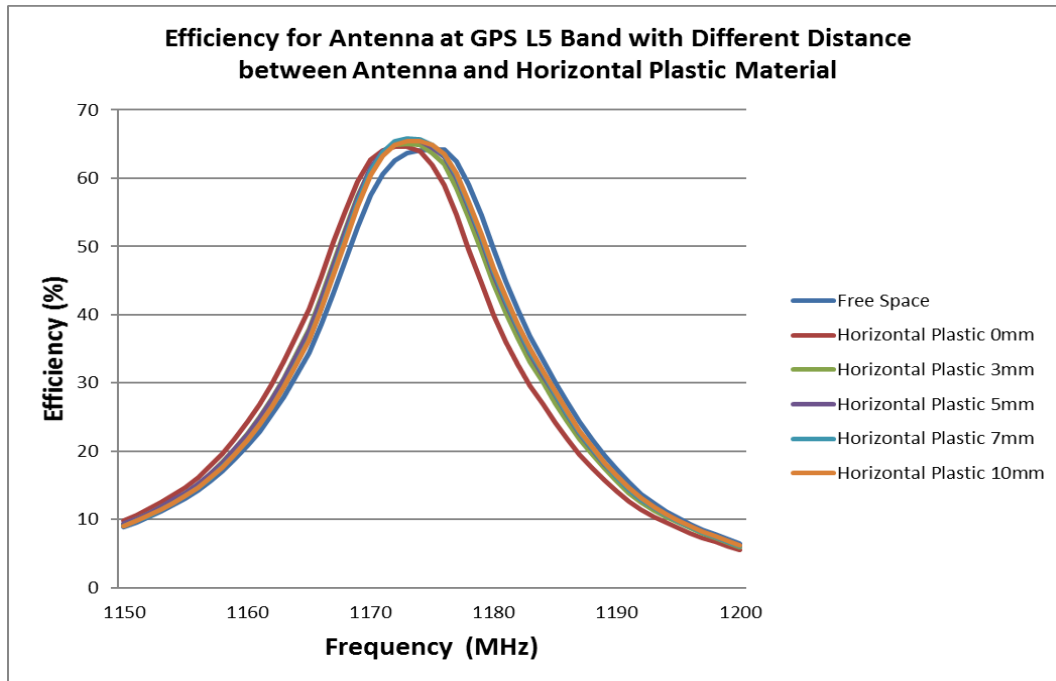


**FIGURE 5.4.1 RETURN LOSS OF ANTENNA AT GPS L5 BAND AT DIFFERENT DISTANCES BETWEEN ANTENNA AND HORIZONTAL PLASTIC MATERIAL**

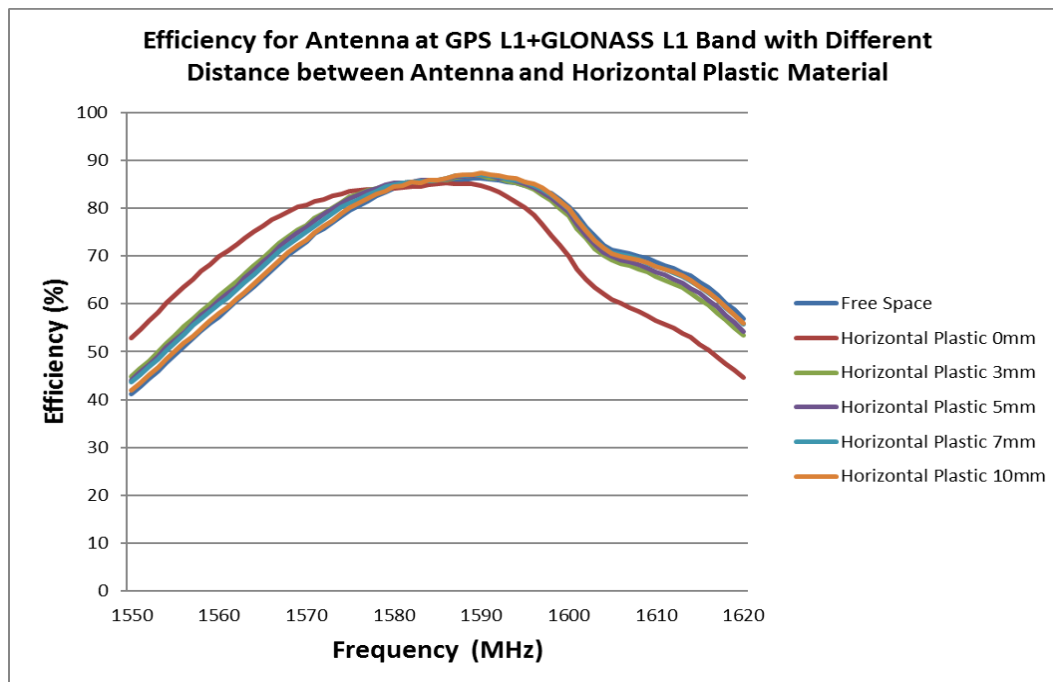


**FIGURE 5.4.2 RETURN LOSS OF ANTENNA AT GPS L1+GLONASS L1 BAND AT DIFFERENT DISTANCES BETWEEN ANTENNA AND HORIZONTAL PLASTIC MATERIAL**

REVISION: <b>A</b>	ECR/ECN INFORMATION: EC No: 609778 DATE: 2019/03/07	TITLE: <b>GPS L1/L5 &amp; Glonass 36mm Stacked Patch Sing Feed Application Specification</b>	SHEET No. <b>33 of 36</b>
DOCUMENT NUMBER: <b>AS-2116240001</b>	CREATED / REVISED BY: Liu Hai 2019/03/05	CHECKED BY: Cheng Kang 2019/03/05	APPROVED BY: Andy Zhang 2019/03/05

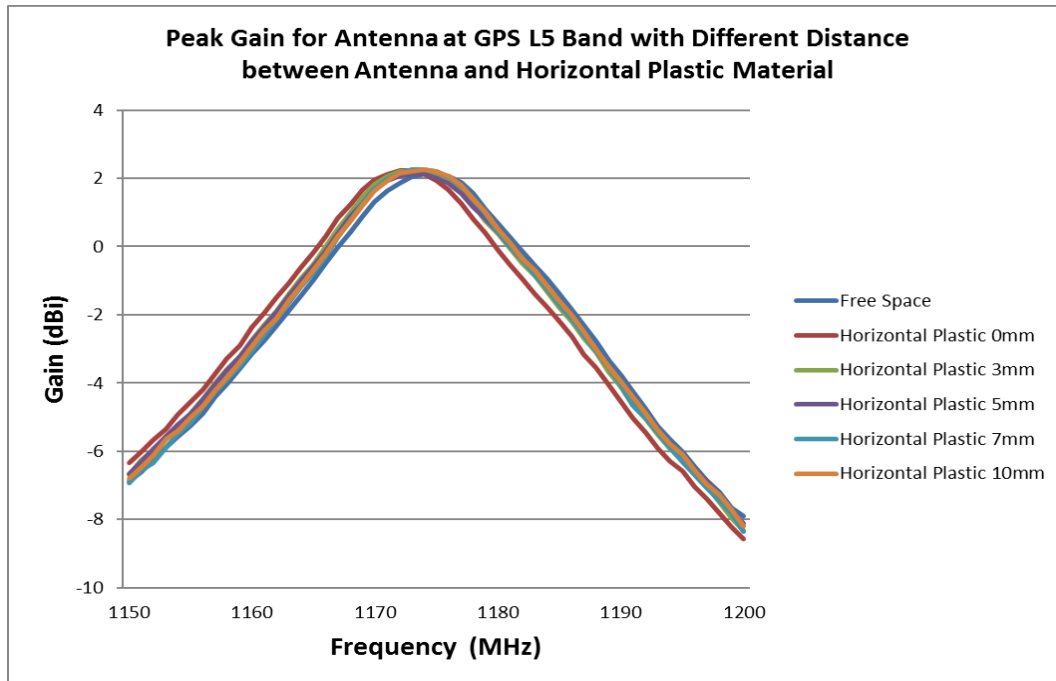


**FIGURE 5.4.3 EFFICIENCY OF ANTENNA AT GPS L5 BAND AT DIFFERENT DISTANCES BETWEEN ANTENNA AND HORIZONTAL PLASTIC MATERIAL**

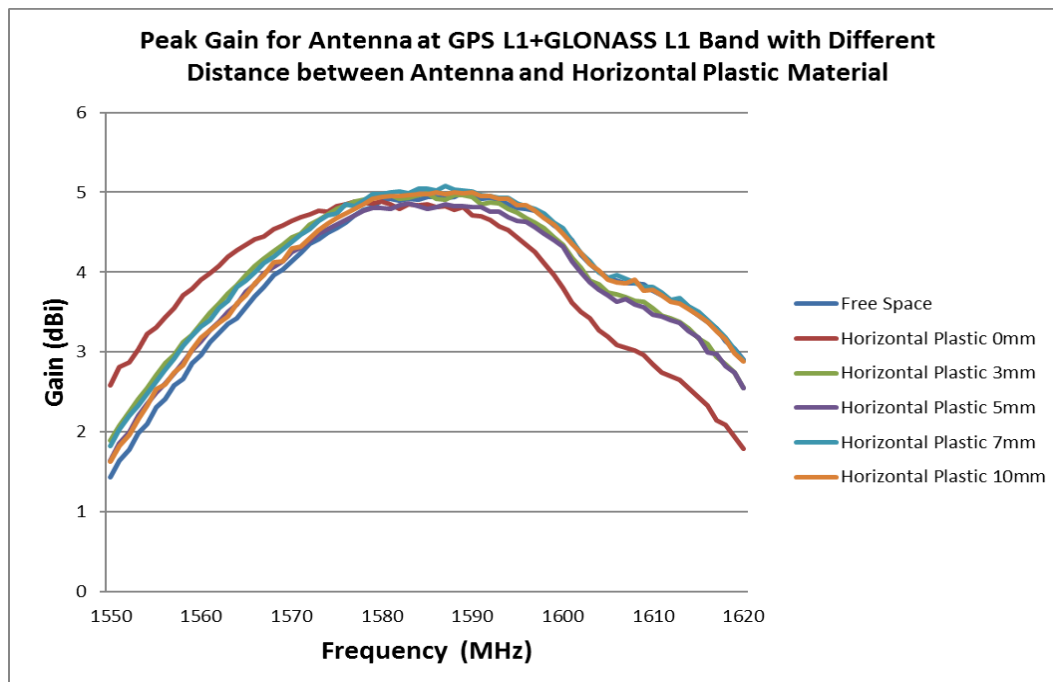


**FIGURE 5.4.4 EFFICIENCY OF ANTENNA AT GPS L1+GLONASS L1 BAND AT DIFFERENT DISTANCES BETWEEN ANTENNA AND HORIZONTAL PLASTIC MATERIAL**

REVISION: <b>A</b>	ECR/ECN INFORMATION: EC No: 609778 DATE: 2019/03/07	TITLE: <b>GPS L1/L5 &amp; Glonass 36mm Stacked Patch Sing Feed Application Specification</b>	SHEET No. <b>34 of 36</b>
DOCUMENT NUMBER: <b>AS-2116240001</b>	CREATED / REVISED BY: Liu Hai 2019/03/05	CHECKED BY: Cheng Kang 2019/03/05	APPROVED BY: Andy Zhang 2019/03/05

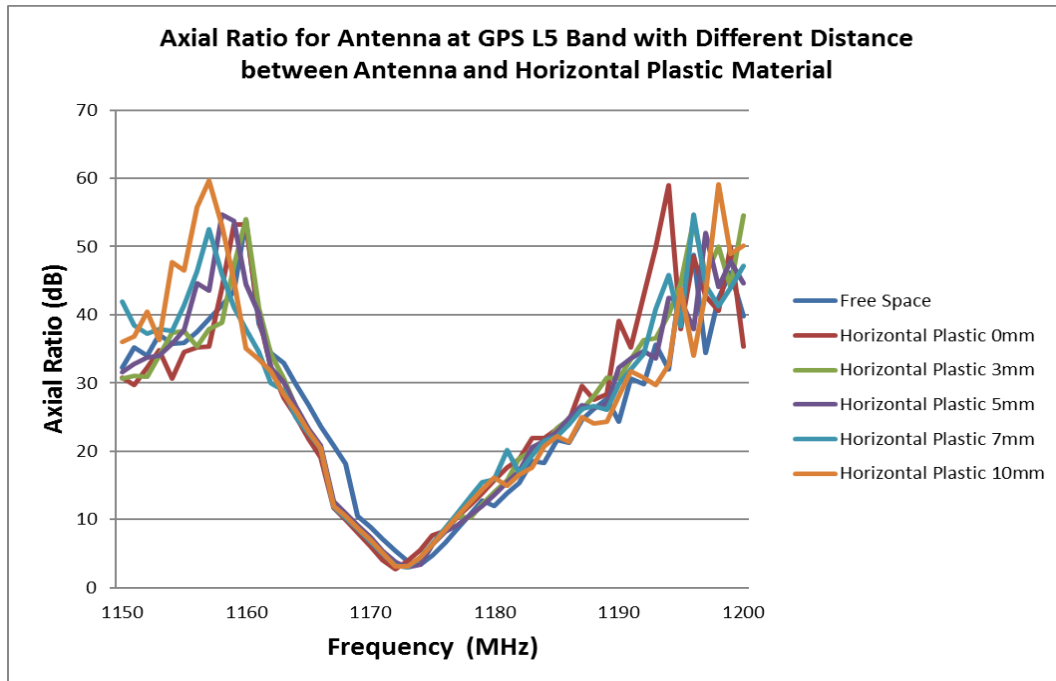


**FIGURE 5.4.5 PEAK GAIN OF ANTENNA AT GPS L5 BAND AT DIFFERENT DISTANCES BETWEEN ANTENNA AND HORIZONTAL PLASTIC MATERIAL**

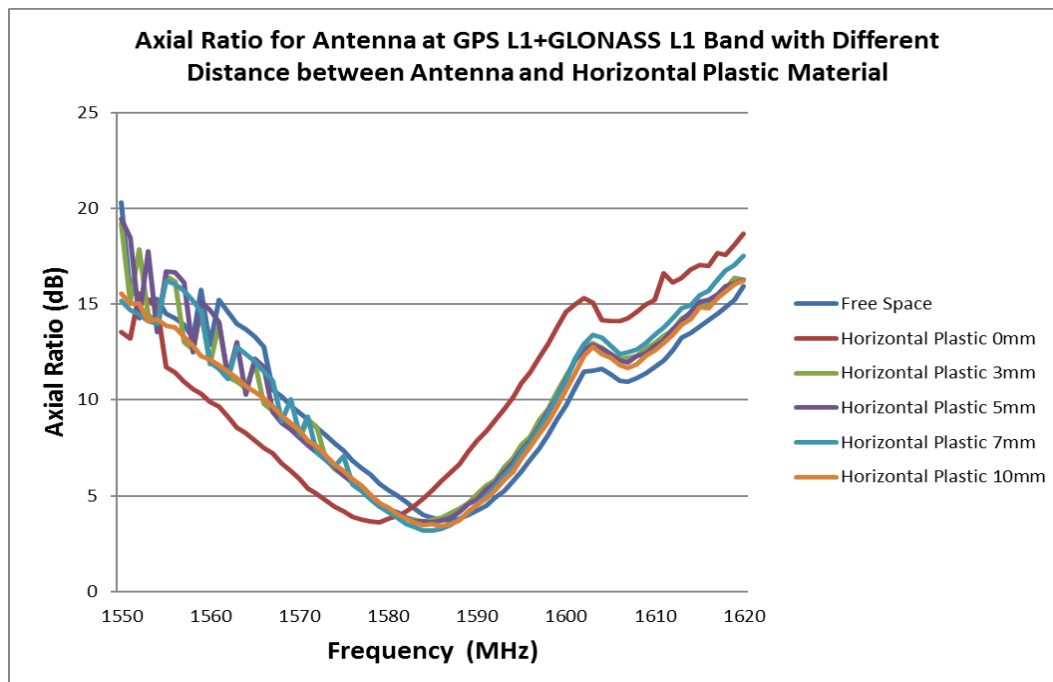


**FIGURE 5.4.6 PEAK GAIN OF ANTENNA AT GPS L1+GLONASS L1 BAND AT DIFFERENT DISTANCES BETWEEN ANTENNA AND HORIZONTAL PLASTIC MATERIAL**

REVISION: <b>A</b>	ECR/ECN INFORMATION: EC No: 609778 DATE: 2019/03/07	TITLE: <b>GPS L1/L5 &amp; Glonass 36mm Stacked Patch Sing Feed Application Specification</b>	SHEET No. <b>35 of 36</b>
DOCUMENT NUMBER: <b>AS-2116240001</b>	CREATED / REVISED BY: Liu Hai 2019/03/05	CHECKED BY: Cheng Kang 2019/03/05	APPROVED BY: Andy Zhang 2019/03/05



**FIGURE 5.4.7 AXIAL RATIO OF ANTENNA AT GPS L5 BAND AT DIFFERENT DISTANCES BETWEEN ANTENNA AND HORIZONTAL PLASTIC MATERIAL**



**FIGURE 5.4.8 AXIAL RATIO OF ANTENNA AT GPS L1+GLONASS L1 BAND AT DIFFERENT DISTANCES BETWEEN ANTENNA AND HORIZONTAL PLASTIC MATERIAL**

REVISION: <b>A</b>	ECR/ECN INFORMATION: EC No: 609778 DATE: 2019/03/07	TITLE: <b>GPS L1/L5 &amp; Glonass 36mm Stacked Patch Sing Feed Application Specification</b>	SHEET No. <b>36 of 36</b>
DOCUMENT NUMBER: <b>AS-2116240001</b>	CREATED / REVISED BY: Liu Hai 2019/03/05	CHECKED BY: Cheng Kang 2019/03/05	APPROVED BY: Andy Zhang 2019/03/05