



FEATURES

- RoHS compliant
- Low profile
- Surface mount
- Inductance range from 1.0μH to 1.0mH
- Tape & reel
- UL 94V-0 materials
- J-STD-020-C reflow

PRODUCT OVERVIEW

The 2900L series is a lower profile version of our 2900 series range of bobbin-wound, shielded inductors. They are suitable for power-line filtering found in consumer electronics such as desktop computers, handheld devices and GPS systems, as well as in a vast range of industrial and telecom applications including network hubs, bridges & routers, and high frequency wireless communication devices.

These surface mount inductors are extremely compact and have an integral shield, making them useful in EMI sensitive applications.

SELECTION GUIDE

Order Code	Inductance (10kHz, 0.1VAc)		Idc ²	Rdc
	Nom.	Min. – Max.	Max.	Max.
	μH	μH	A	mΩ
29L102C	1.0	0.70 – 1.30	4.6	13
29L152C	1.5	1.02 – 1.88	4.2	15
29L222C	2.2	1.76 – 3.26	3.0	20
29L332C	3.3	2.26 – 4.20	2.6	25
29L472C	4.7	3.31 – 6.15	2.2	31
29L682C	6.8	4.75 – 8.83	1.8	48
29L103C	10	8.4 – 12.6	1.55	64
29L153C	15	11.8 – 17.7	1.23	84
29L223C	22	17.1 – 25.7	1.05	114
29L333C	33	25.7 – 38.6	820mA	174
29L473C	47	36.7 – 55.0	800mA	223
29L683C	68	54.7 – 82.1	530mA	307
29L104C	100	79.0 – 119	480mA	456
29L154C	150	121 – 181	430mA	738
29L224C	220	178 – 266	360mA	1060
29L334C	330	267 – 403	300mA	1670
29L474C	470	380 – 570	220mA	2410
29L684C	680	560 – 840	200mA	3610
29L105C	1000	816 – 1224	140mA	6480

ABSOLUTE MAXIMUM RATINGS

Operating free air temperature range	-40°C to 85°C
Storage temperature range	-40°C to 125°C

SOLDERING INFORMATION¹

Peak reflow solder temperature	250°C
Pin finish	Bright tin

PACKAGE SPECIFICATIONS

Mechanical Dimensions

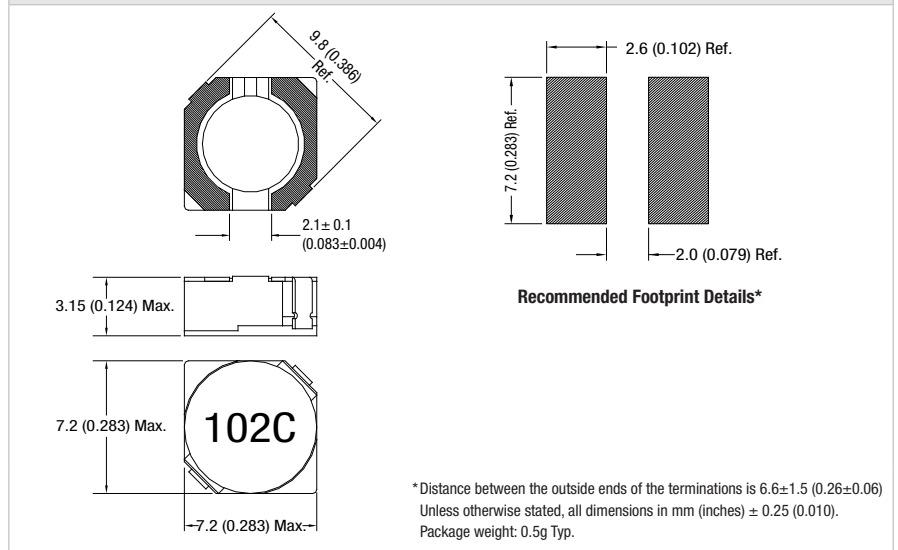

*Distance between the outside ends of the terminations is 6.6±1.5 (0.26±0.06)
 Unless otherwise stated, all dimensions in mm (inches) ± 0.25 (0.010).
 Package weight: 0.5g Typ.

1 For further information, please visit www.murata-ps.com/rohs
 2 The maximum DC current is the value at which the inductance falls to 75% of its nominal value or when its temperature rise reaches 40°C, whichever is sooner.
 All specifications typical at T_A=25°C



INDUCTANCE Vs CURRENT

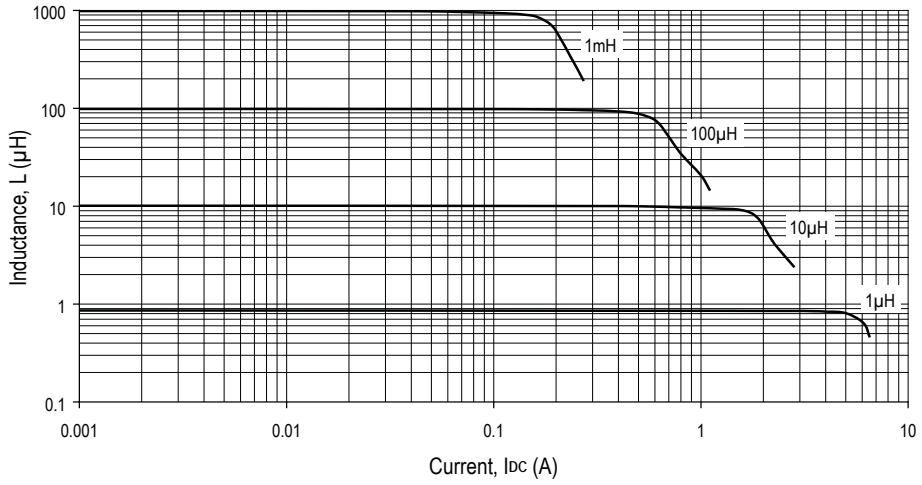

TEMPERATURE Vs CURRENT

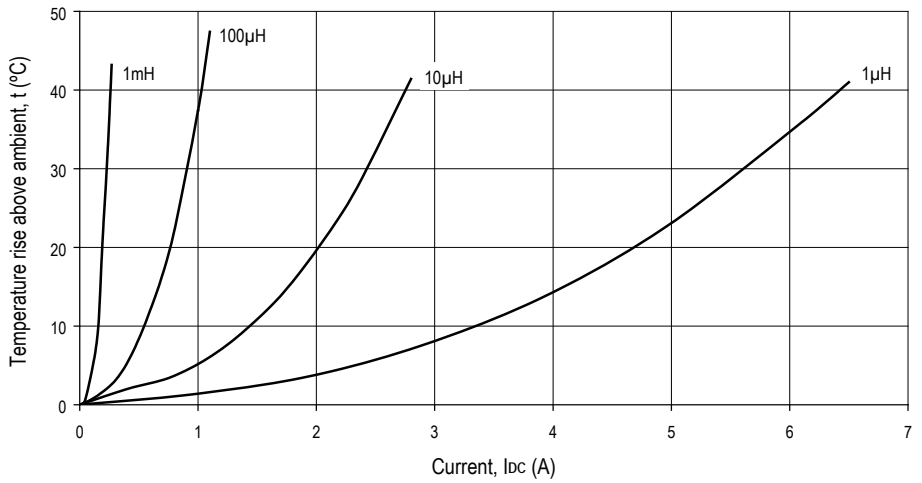

INDUCTANCE Vs FREQUENCY

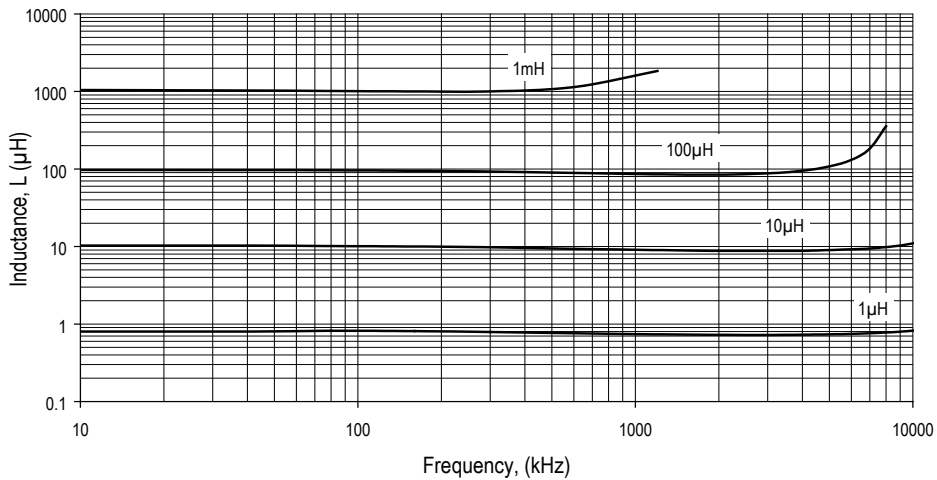

PACKAGE SPECIFICATIONS

Reel Dimensions

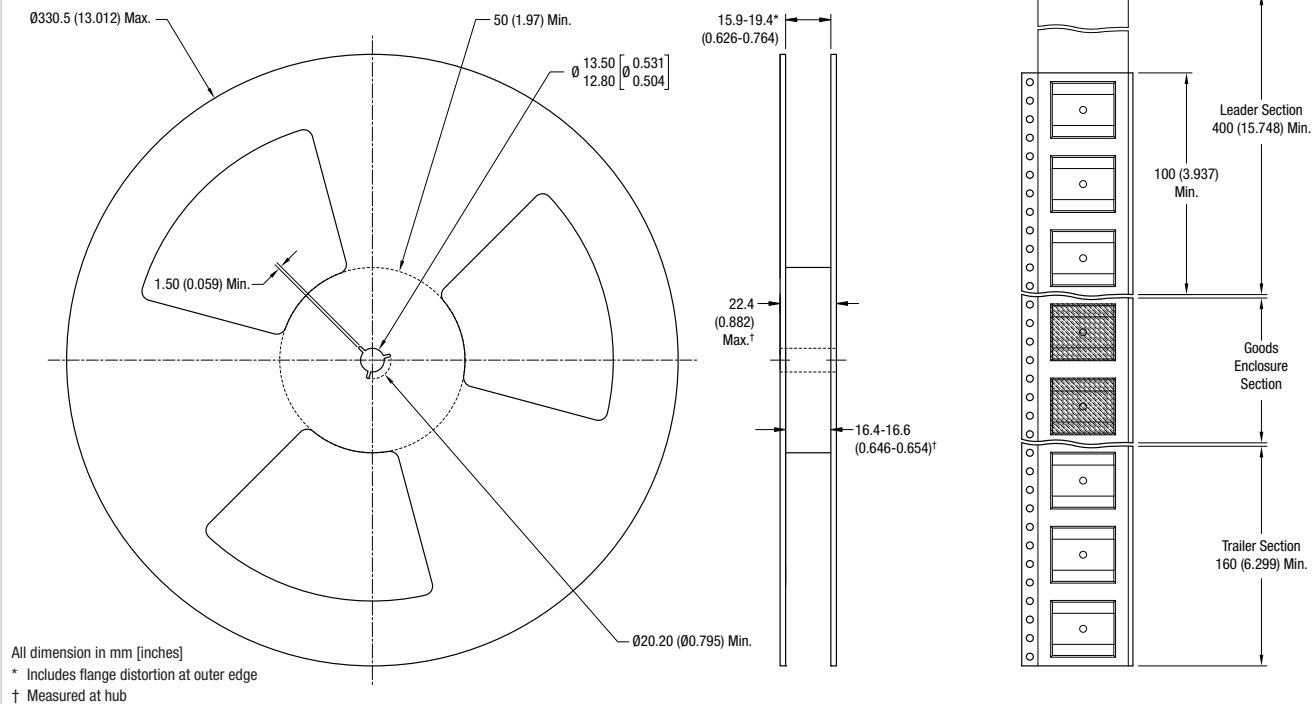

Tape Outline Dimensions

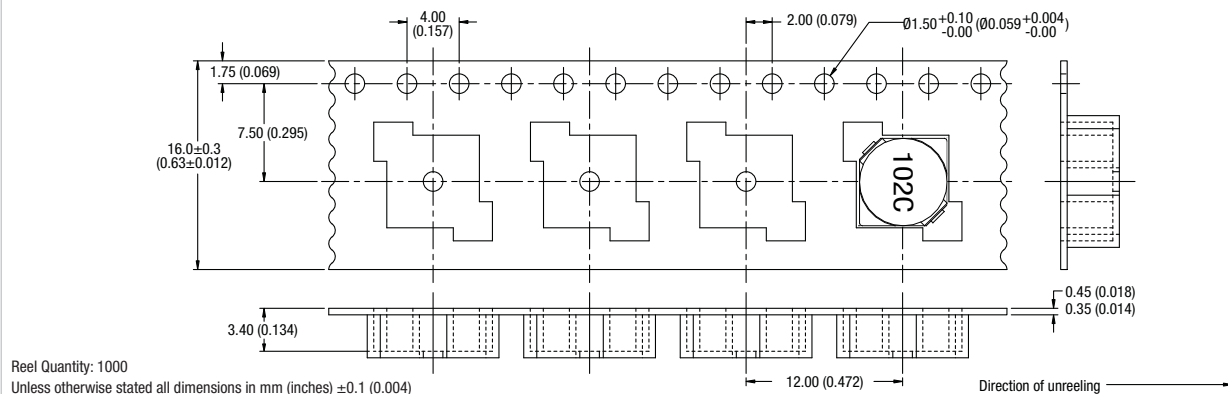

Murata Power Solutions, Inc.
11 Cabot Boulevard, Mansfield, MA 02048-1151 U.S.A.
ISO 9001 and 14001 REGISTERED

Murata Power Solutions, Inc. makes no representation that the use of its products in the circuits described herein, or the use of other technical information contained herein, will not infringe upon existing or future patent rights. The descriptions contained herein do not imply the granting of licenses to make, use, or sell equipment constructed in accordance therewith. Specifications are subject to change without notice.
© 2011 Murata Power Solutions, Inc.