

**Discontinued**

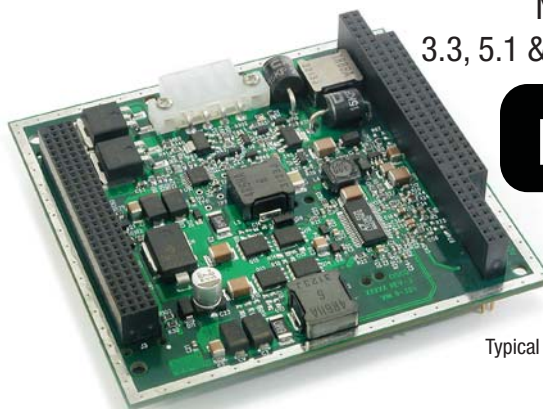

Typical unit

## FEATURES

- 46 Watts for Mobile Access Router to IP/Networks
- PC/104-Plus compatible/stackable, powering Cisco system cards
- 9 to 32V input range, supporting both 12V and 24V vehicle batteries
- Reverse input voltage protection
- Automotive transient protection
- Efficiency to 92.5% @ full load
- No derating to +85°C, 100 lfm
- Independently regulated +3.3V, +5.1V and +12V outputs
- Power up/down sequencing
- Low 25mVp-p ripple/noise
- Power good LED and external signal
- Compact 3.775" × 3.55" × 0.6" package, standard PC/104-Plus pinout
- Stable no-load condition
- Thermal shutdown with warning
- Fully I/O protected
- UL/IEC/EN60950-1 certification pending

## PRODUCT OVERVIEW

Murata Power Solutions' MAPC-104 non-isolated, triple output DC/DC converter is designed to power the Cisco 3200 Mobile Access Router and is compliant to PC/104-Plus specifications. The equipment ideally suits integration into public safety, defense, homeland security and commercial transportation vehicles, whether on land, in water or air, and is employed for powering secure data, voice and video communications across multiple wireless networks.

The MAPC-104 is a high performance, compact and rugged power supply which operates in the harshest conditions, withstanding input transient voltages according to SAE J1455 and J1211. It converts the vehicle's standard battery voltage of 12V or 24V ( $V_{IN}$  range from 9 to 32 Volts) to three fully regulated outputs of 3.3V @ 6A, 5.1V @ 6.3A and 12V @ 100mA up to a total output power of 46 Watts. Taking full advantage of a synchronous-rectifier, buck/boost topology, MAPC-104's boast outstanding efficiency of up to 92.5%, enabling full-power operation to ambient temperatures as high as +85°C with 100 lfm air flow.

The compact 3.775" x 3.55" x 0.60" (95.9 x 90.2 x 15.2mm) open frame, triple output DC/DC power card is mechanically and electrically compliant to PC/104-Plus specifications. Operating with the Cisco designed system cards, the MAPC-104 is considered part of the host, which requires the 3.3V (but no -5V/-12V) supply provided.

Assembled using fully automated, SMT-on-pcb techniques, MAPC-104s provide stable no-load operation, excellent line and load regulation ( $\pm 1\%$  max.), quick step response (200µsec), and low output ripple/noise (25mVp-p).

All devices feature full I/O fault protection including: input overvoltage and undervoltage shutdown, power up/down sequencing, output overvoltage, output current limiting, short-circuit protection, power good (LED indicator and external signal), overtemperature warning and thermal shutdown.

All models are certified to IEC/EN/UL60950-1 safety standards. Selected models include RoHS compliance.

## Performance Specifications<sup>①</sup>

Model MAPC-104	Output							Input			Efficiency		Package/ Pinout
	$V_{OUT}$ (Volts)	$I_{OUT}$ (Amps)		R/N (mVp-p) <sup>②</sup>		Regulation (Max.) <sup>③</sup>		$V_{IN}$ (Volts)		$I_{IN}$ <sup>④</sup> (mA/A)	Min.	Typ.	
		Nom.	Max.	Typ.	Max.	Line	Load	Nom.	Range				
Output 1	3.3	5	6	25	35	$\pm 1\%$	$\pm 1\%$	12	9-32	35/4	91%	92.5%	C46 See pages 2, 3 for Pinout
Output 2	5.1	5.46	6.3	25	50	$\pm 1\%$	$\pm 1\%$						
Output 3	12	0.07	0.1	20	35	$\pm 1\%$	$\pm 1\%$	24	9-32	35/4	89.5%	91%	

<sup>①</sup> Typical at  $T_A = +25^\circ\text{C}$  under nominal line voltage and nominal-load conditions, unless noted.

<sup>②</sup> Ripple/Noise (R/N) is tested/specified over a 20MHz bandwidth. All models are specified with an external 0.1µF multi-layer ceramic capacitor installed across each output pin.

<sup>③</sup> Devices have no minimum-load requirements and will regulate under no-load conditions. Regulation specifications describe the output-voltage deviation as the line voltage or load is varied from its midpoint value to either extreme.

<sup>④</sup> Nominal line voltage, no-load/full-load conditions.



**MECHANICAL SPECIFICATIONS**

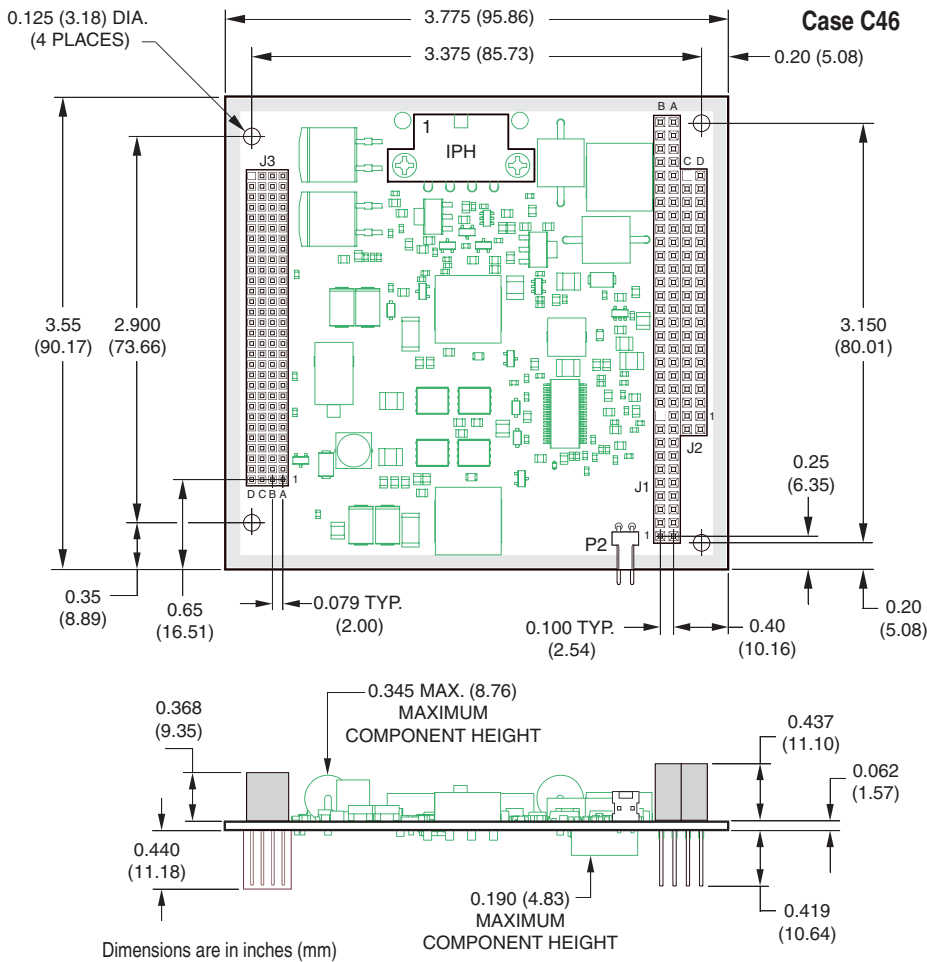

**ORDERING GUIDE & PART NUMBER STRUCTURE**

Model Number	Auxiliary Power Connector (P2)
MAPC-104	Not installed
MAPC-104-5V	Installed

**MAPC-104 - 5V - C**

PC/104-Triple Output Power Converter

Auxiliary Power Connector (P2)  
Blank = Not installed  
5V = P2 is installed

RoHS Hazardous  
Substance Compliance  
Y = RoHS-5 (with lead)  
C = RoHS-6 (no lead)

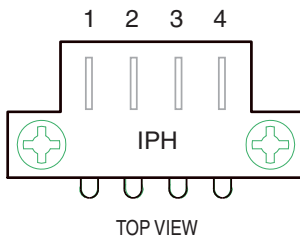
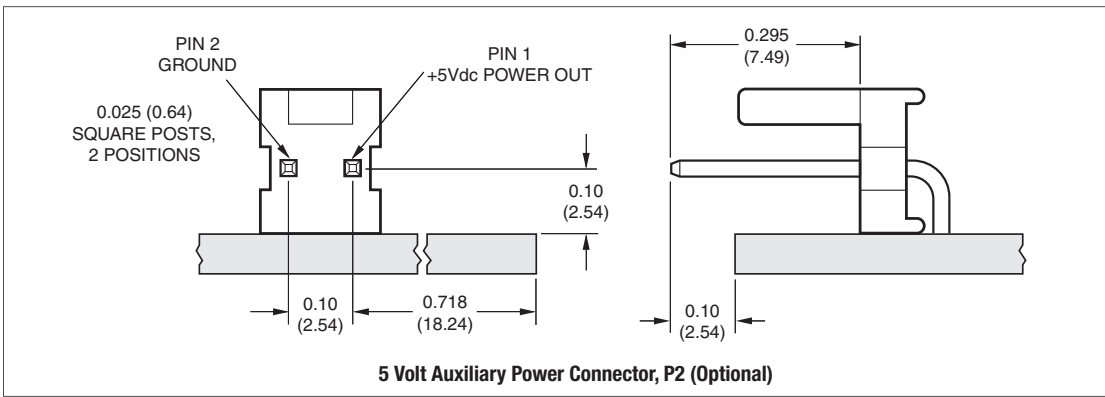

**Figure 1. MAPC-104 Input Power Head**

**IPH Mating connector: Molex 5557 (39-01-4040)**

Pin	Assignment	Functional Description
1	OT_Warn Out	Overtemperature Warning
2	Pwr_LED_Drive Out	External Power Good LED Driver
3	V <sub>IN</sub> -	Input Ground
4	V <sub>IN</sub> +	Positive Input

Figure 2. MAPC-104 (PC/104-plus) Bus Signal Assignments

J3/P3				
Pin	A	B	C	D
1	GND ②	Reserved	+5.1V	AD00
2	VI/O	AD02	AD01	+5.1V
3	AD05	GND	AD04	AD03
4	C/BE0*	AD07	GND	AD06
5	GND	AD09	AD08	GND
6	AD11	VI/O	AD10	M66EN
7	AD14	AD13	GND	AD12
8	+3.3V	C/BE1*	AD15	+3.3V
9	SERR*	GND	SB0*	PAR
10	GND	PERR*	+3.3V	SDONE
11	STOP*	+3.3V	LOCK*	GND
12	+3.3V	TRDY*	GND	DEVSEL*
13	FRAME*	GND	IRDY*	+3.3V
14	GND	AD16	+3.3V	C/BE2*
15	AD18	+3.3V	AD17	GND
16	AD21	AD20	GND	AD19
17	+3.3V	AD23	AD22	+3.3V
18	IDSEL0	GND	IDSEL1	IDSEL2
19	AD24	C/BE3*	VI/O	IDSEL3
20	GND	AD26	AD25	GND
21	AD29	+5.1V	AD28	AD27
22	+5.1V	AD30	GND	AD31
23	REQ0*	GND	REQ1*	VI/O
24	GND	REQ2*	+5.1V	GNT0*
25	GNT1*	VI/O	GNT2*	GND
26	+5.1V	CLK0	GND	CLK1
27	CLK2	+5.1V	CLK3	GND
28	GND	INTD*	+5.1V	RST*
29	+12V	INTA*	INTB*	INTC*
30	NA (-12V) ③	Reserved	Reserved	3.3V KEY ②

Figure 3. MAPC-104 (PC/104-Reference) Bus Signal Assignments

J2/P2			J1/P1		
Pin	D	C	Pin	A	B
0	GND	GND	1	IOCHCK*	GND
1	MEMCS16*	SBHE*	2	D7	RSTDRV
2	IOCS16*	LA23	3	D6	+5.1V
3	IRQ10	LA22	4	D5	IRQ9
4	IRQ11	LS21	5	D4	NA (-5V) ③
5	IRQ12	LS20	6	D3	DRQ2
6	IRQ15	LS19	7	D2	NA (-12V) ③
7	IRQ14	LA18	8	D1	ENDXFR*
8	DACK0*	LA17	9	D0	+12V
9	DRQ0	MEMR*	10	IOCHRDY	KEY ②
10	DACK5*	MEMW*	11	AEN	SMEMW*
11	DRQ5	SD8	12	A19	SMEMR*
12	DACK6*	SD9	13	A18	IOW*
13	DRQ6	SD10	14	A17	IOR*
14	DACK7*	SD11	15	A16	DACK3*
15	DRQ7	SD12	16	A15	DRQ3
16	+5.1V	SD13	17	A14	DACK1*
17	MASTER*	SD14	18	A13	DRQ1
18	GND	SD15	19	A12	REFRESH*
19	GND	KEY ②	20	A11	SYSCLK
			21	A10	IRQ7
			22	A9	IRQ6
			23	A8	IRQ5
			24	A7	IRQ4
			25	A6	IRQ3
			26	A5	DACK2*
			27	A4	TC
			28	A3	BALE
			29	A2	+5.1V
			30	A1	OSC
			31	A0	GND
			32	GND	GND

① The shaded area denotes power or ground signals.

② The KEY pins are to guarantee proper module installation:

J3/P3, pin A1 is electrically connected to GND for shielding

J3/P3, pin D30 is removed and the female side is plugged for 3.3V I/O

J2/P2, pin C19 is keyed, pin is removed and the female side is plugged

J1/P1, pin B10 is keyed, pin is removed and the female side is plugged

③ J3/P3, pin A30 and J1/P1, pins B5 and B7 are not used. Pin assignments for -5V and -12V are for reference only.

### Auxiliary 5V Power Connector, P2

#### Specifications (typical unless noted)

<b>Power Output</b> ①	+5 Vdc at 1 Amp maximum
<b>Power Characteristics</b>	See MAPC-104 Specifications
<b>P2 Header Type</b>	AMP/Tyco Electronics 640455-2
<b>Contact Dimensions</b>	Two 0.025" square posts, 0.3" long, 0.10" spacing on centers. See drawings.
<b>Contact Material</b>	Tin plating over copper alloy
<b>Contact Assembly Force</b>	3 lbs. (13N)
<b>Mating Connector</b> ②	Single-row, 2-position IDC on 0.10" spacing
<b>Environmental</b>	Compatible with host MAPC-104 system

① The contacts are rated at 5 Amps 250Vac. However, whatever current is drawn must be *summed* with current powering the PC-104 system.

② A suggested mating connector is AMP/Tyco Electronics MTA-100 Series, part number 647000-2. See also the CST-100 Series.

For the MAPC-104-5V model version, spare +5 Vdc power may be taken from the P2 connector which is adjacent to the pin 1 end of the J1 connector (see drawings). Be aware that this power is generated on the MAPC-104 and therefore is in addition to whatever 5V current is used by the host PC-104 system. All power characteristics (regulation, tempco, ripple, etc.) are derived from the MAPC-104.

### Performance/Functional Specifications

Typical @ T<sub>A</sub> = +25°C under nominal line voltage and full-load conditions unless noted. ①

Input	
Input Voltage Range	9–32 Volts (12V or 24V battery)
Transient Voltage Protection	125V/100ms (30kVA)
Overvoltage Shutdown	32–36 Volts (34V typical)
Overvoltage Protection	48V/5 minutes
Start-Up Threshold ②	9–10 Volts (9.4V typical)
Undervoltage Shutdown ②	7–9 Volts (8.2V typical)
Input Current	See Performance Specifications
Input Reflected Ripple Current ③	45mVp-p
Internal Filter Type	Pi
Reverse-Polarity Protection	Yes (external fuse mandatory)
Output	
Minimum Loading Per Output	No load
Maximum Capacitive Load	2000µF (+3.3V) 1000µF (+5.1V) 500µF (+12V)
V <sub>out</sub> Accuracy (50% load)	±3% maximum
Temperature Coefficient	±0.02%/°C
Ripple/Noise (20MHz BW)	See Performance Specifications
Line/Load Regulation	See Performance Specifications
Efficiency	See Performance Specifications
Current Limit Inception ④ (97% V <sub>out</sub> , each other output @ 0 Amps)	7-9 Amps (+3.3V) 8.5-11 Amps (+5.1V) 0.2-0.5 Amps (+12V)
Short Circuit Current (Zener)	2.65 Amps (+3.3V) 3.24 Amps (+5.1V) 0.12 Amps (+12V)
Overvoltage Protection ⑨	3.9V (+3.3V) 6V (+5.1V) 13V (+12V)
Power Good within 7-10% of V <sub>out</sub>	See Tech Notes (LED and external Signal)
Dynamic Characteristics	
Dynamic Load Response ⑤ (50-100% step to within 1% of V <sub>out</sub> )	200µsec (+3.3V & +5.1V) 100µsec (+12V)
Power-up Sequencing ⑥ (5.1V power-down before 3.3V)	2-6msec
Power-down Sequencing ② (5.1V power-down before 3.3V)	1-4msec
Switching Frequency	320 kHz (+3.3V & +5.1V) 1120 kHz (+12V)
Environmental	
Calculated MTBF ⑦	3,129,938 hours
Operating Ambient Temperature ⑧ With 100 lfm Air Flow, no derating	-40 to +85°C
Board Temperature	-40 to +105°C
Thermal Shutdown	+112°C to 118°C
Thermal Shutdown Warning	27 to 33 seconds
2nd Level Thermal Shutdown	+122 to +128°C
Storage Temperature	-40 to +105°C
Physical	
Dimensions	See Mechanical Specifications
Connector and Pin Material	According to PC/104-plus Spec
Weight	3.6 ounces (102 grams)
Insulation Level	Non-isolated

- ① All models are tested and specified with a single, external, 0.1µF, multi-layer ceramic output capacitor on each output and no external input capacitors, unless otherwise noted. All models will effectively regulate under no-load conditions (with perhaps a slight increase in output ripple/noise).
- ② See Technical Notes/Performance Curves for additional explanations and details.
- ③ Input Ripple Current is tested/specified over a 5-20MHz bandwidth with an external 33µF input capacitor and a simulated source impedance of 220µF and 12µH. See I/O Filtering, Input Ripple Current and Output Noise for details.
- ④ The Current-Limit-Inception point is the output current level at which the converter's power-limiting circuitry drops the output voltage 3% from its initial value. See Output Current Limiting and Short-Circuit Protection for more details.
- ⑤ See Dynamic Load Response for detailed results including switching frequencies.
- ⑥ For Start-Up-Time specifications, output settling time is defined as the output voltage having reached ±1% of its final value and the load current having reached at least 80% of its final value.
- ⑦ MTBF is calculated using TELCORDIA SR-332 Method 1 Case 3, Issue 1, ground fixed, +30°C ambient air and full-load conditions.
- ⑧ All models are fully operational and meet all published specifications, including "cold start," at -40°C.
- ⑨ The highly unlikely, simultaneous failure of several specific on-board components could result in the MAPC-104's input voltage appearing at its output, despite the unit's output overvoltage protection mechanisms. In this rare situation, the Power Good signal (IPH pin 2, Pwr\_LED\_Drive) will be deactivated and systems monitoring Power Good will eventually shut down. If you are using an MAPC-104 to power a load that must be protected against any and all possible overvoltages, no matter how rare, you will have to provide the protection external to the MAPC-104. Please contact MPS for recommendations.

#### Absolute Maximum Ratings

<b>Input Voltage:</b>	
Continuous	36 Volts
Up to 5 minutes maximum	48 Volts
Transient	125V (30kVA)
<b>Input Reverse-Polarity Protection</b>	External fuse mandatory
<b>Output Current</b>	Current limited. Devices can withstand sustained output short circuit.

These are stress ratings. Exposure of devices to any of these conditions may adversely affect long-term reliability. Proper operation under conditions other than those listed in the Performance/Functional Specifications Table is not implied.

#### Connector Designations

The official PC/104 bus specification identifies the standard interboard bus connections as paired J1/P1 and J2/P2 on one side and J3/P3 on the other side. However, J1/P1/J2/P2 is physically all one big 4-row connector with J1/J2 bus receptacle sockets (female) on the top side and P1/P2 pins (male) on the bottom. This arrangement provides interboard pass-through connections between PC/104 boards. MPS refers to this single connector as "J1."

MPS's auxiliary connectors (the IPH and the 5V Auxiliary Power Connector) are internally designated P1 and P2 respectively and this nomenclature may appear on the board silkscreening. This is purely an artifact of automated sequential part numbering in our CAD system and has no relation to the standard PC/104 interboard bus connectors. Don't get the connectors confused since they are all very different types and locations!

## Typical Performance Curves

Efficiency vs. Line @ 46W

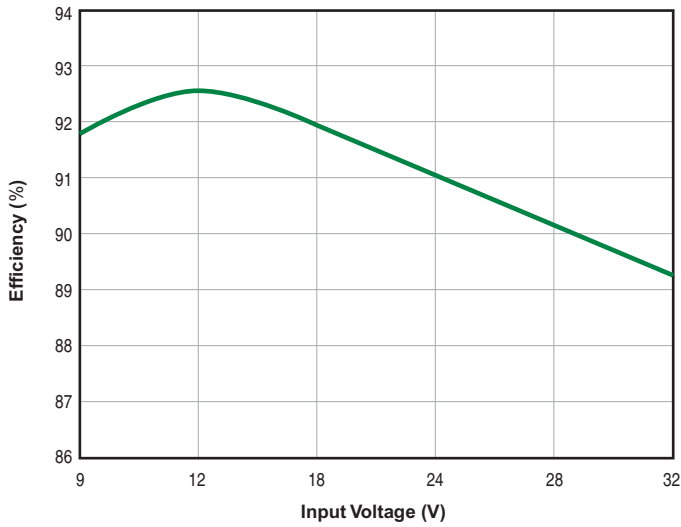

3.3V<sub>OUT</sub> Efficiency vs. Line Voltage and Load Current  
(5.1V @ 5.46A and 12V @ 0.07A)

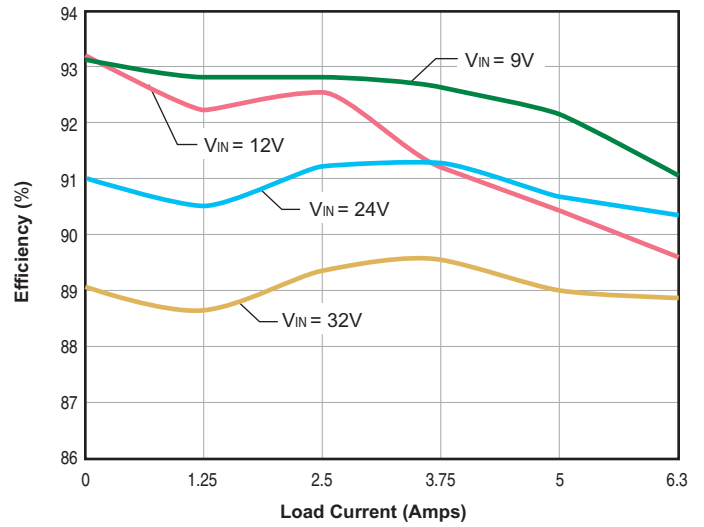

5.1V<sub>OUT</sub> Efficiency vs. Line Voltage and Load Current  
(3.3V @ 5A and 12V @ 0.07A)

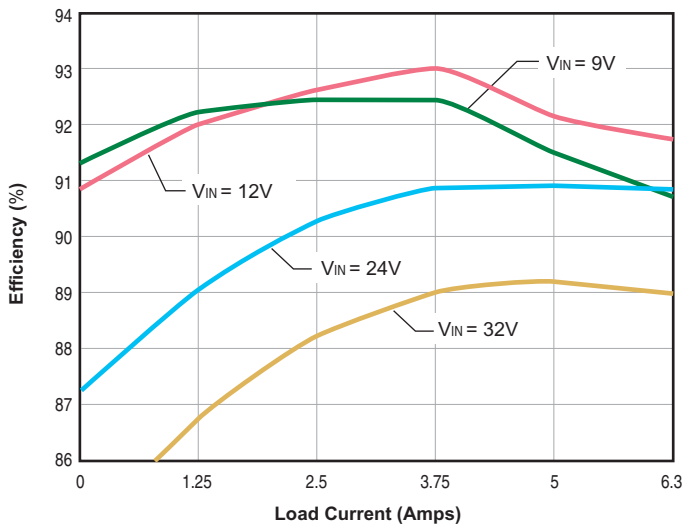

12V<sub>OUT</sub> Efficiency vs. Line Voltage and Load Current  
(5.1V @ 5.46A and 3.3V @ 5A)

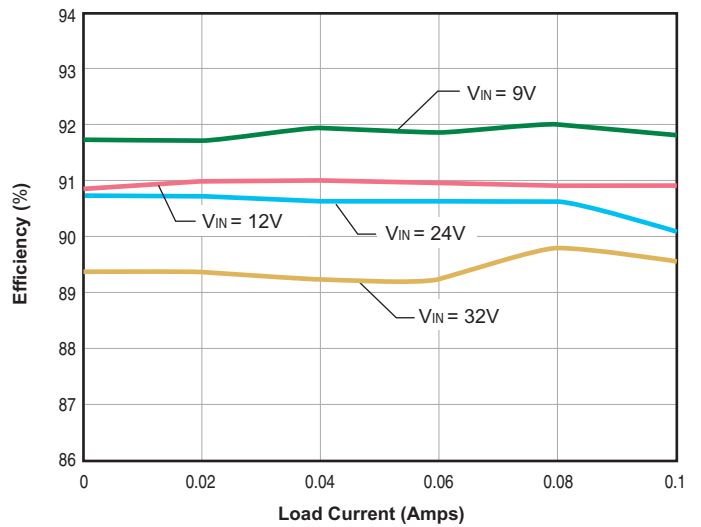

### Self-Protection Features

The MAPC-104 contains two systems for protection of out-of-limit voltages, currents and temperature. These systems control two output lines located on the Input Power Header connector. Both systems operate independently and concurrently. The MAPC-104 will respond to both temperature and voltage/current simultaneously.

The output circuits for both these controls are shown below. Both of them will drive either an external LED lamp and/or a logic circuit. The Overtemperature Warning Circuit assumes that an external pullup resistor is supplied by the user. The Power Good Circuit ("Pwr\_LED\_Drive Out") includes an on-board pullup resistor to drive an external LED with about 15mA.

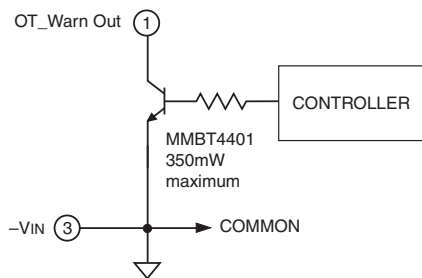

(X) = Input Power Header (IPH) pins

**Typical External Logic Wiring**

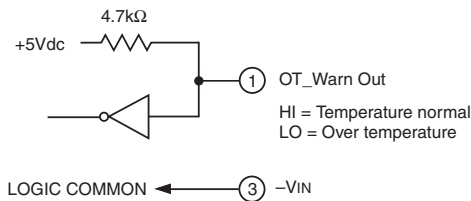

**Typical OT Warning External LED Lamp Wiring**

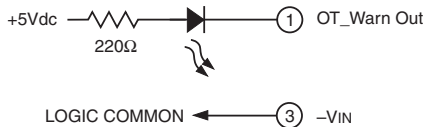

**Figure 1. Overtemperature Warning Circuit**

The transistors in these outputs are either on (typically less than 0.4 Volts out) or off (high impedance state). Depending on how the user wires the external circuit, these indicators have the following sense:

OT\_Warn Out (pin 1):

HI (transistor off) = Temperature is normal

LO (transistor on) = Over temperature condition

Pwr\_LED\_Drive Out (pin 2, pullup to internal +5V):

HI (transistor off) = Power is normal. LED lamp is illuminated.

LO (transistor on) = Power fault, LED lamp is dark

### Overtemperature Operation

The overtemperature system includes a on-board temperature sensor, a local microcontroller with A/D inputs, a timer and hysteresis so that the user may take steps to prevent inadvertant shut down. Operation proceeds as follows: If the on-board temperature exceeds +115°C, the OT\_Warn Output is asserted (LO) by the microcontroller and an internal 30 second software timer is started. The outputs remain powered on.

If the 30-second timer has not expired and the on-board temperature cools below +110°C, the OT\_Warn Output will be deasserted (HI) and operation will continue unchanged.

If the 30-second timer has expired and the temperature still exceeds +115°C, the outputs will shut down. As soon as the on-board temperature cools to less than +110°C, the MAPC-104 will automatically restart and power will be restored to the outputs.

The 5 degree hysteresis between 110 and 115°C prevents rapid cycling of the OT\_Warn Output.

If the on-board temperature reaches +125°C, the outputs will shut down, regardless of the state of the 30-second timer. The temperature must cool to less than +110°C for auto restart.

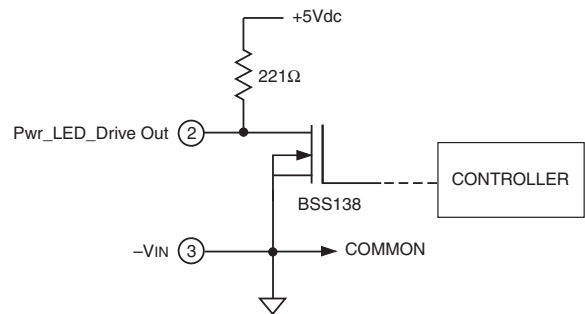

(X) = Input Power Header (IPH) pins

**Typical Power Good External LED Lamp Wiring**

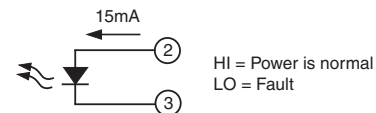

**Figure 2. Overtemperature Warning Circuit**

## Power Good Operation

Local power is measured by several circuits shared with the overtemperature system. The Pwr\_LED\_Drive Output is indirectly controlled by the on-board microcontroller. The on-board PWM switching controller measures +3.3V and +5V output voltages and all output currents. The microcontroller measures input voltage and the +12V output voltage. The system requires that the input voltage is within normal tolerances at all times. If the input voltage is too high very briefly at startup (but not exceeding the absolute input voltage), the system will start normally if the input voltage reaches acceptable limits quickly (under half a second). This typically occurs as a load is applied.

When the system first starts, the Power Good LED (if installed) remains dark briefly until all on-board startup conditions are met (less than half a second) at which point the LED is illuminated. The operation proceeds as follows:

If the outputs on any lines deviate from approximately  $\pm 7\%$  of nominal and/or the output current is excessive, the outputs are all shut down and the Pwr\_LED\_Drive Output is desasserted (LO, lamp dark). The system will attempt to restart in about half a second by briefly turning on all outputs. If successful and the fault is eliminated, the Pwr\_LED\_Drive Output will be asserted (HI, lamp lit) and operation continues.

If the fault condition remains, the system will attempt to restart two more times, spaced about half a second apart. If the fault remains for the third time, the system will shut down and will not retest the fault. The system must now be restored by fully cycling the input power.

The 3-fault countdown only occurs if the fault does not recover continuously throughout the attempted restart interval. An occasional random shutdown and successful restart will not trigger the 3-fault counter. However, external logic should record the frequency and quantity of such shutdowns.

**RoHS-5 compliance** refers to the exclusion of the six hazardous substances in the RoHS specification with the exception of lead. MPS's RoHS-5 products use all the conforming RoHS materials, however our solders are Sn63/Pb37.

