



Standard PM Step Motors

PM25L-024-HHC5

Model Specifications

Model:	PM25L-024-HHC5
Shaft Length:	10mm
Wire Length:	300mm fly lead (no connector)
Wire Holder:	90 deg. Left
Front Plate:	FPH
Electrical:	24V, 600mA
	Bipolar Constant Current
	8 ohms, MS70A

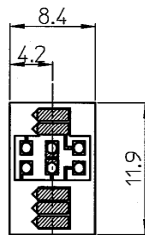
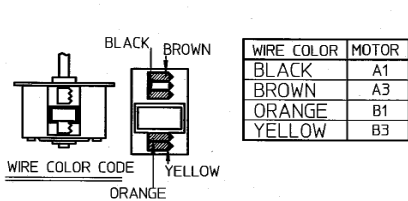

MARKING

NMB-MAT PM25L-024-HHC5
JAPAN H9806
<JAPAN>

NMB-MAT PM25L-024-HHC5
THAILAND TA9806
<THAILAND>

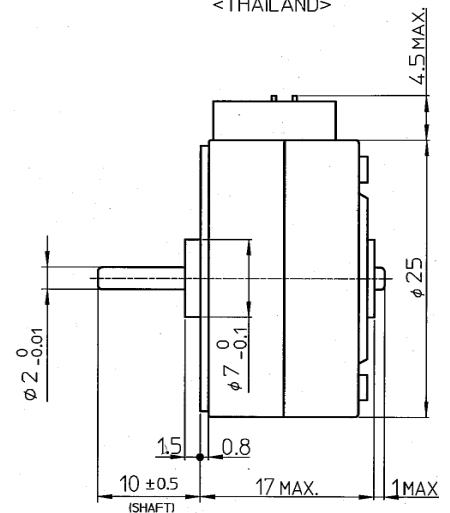
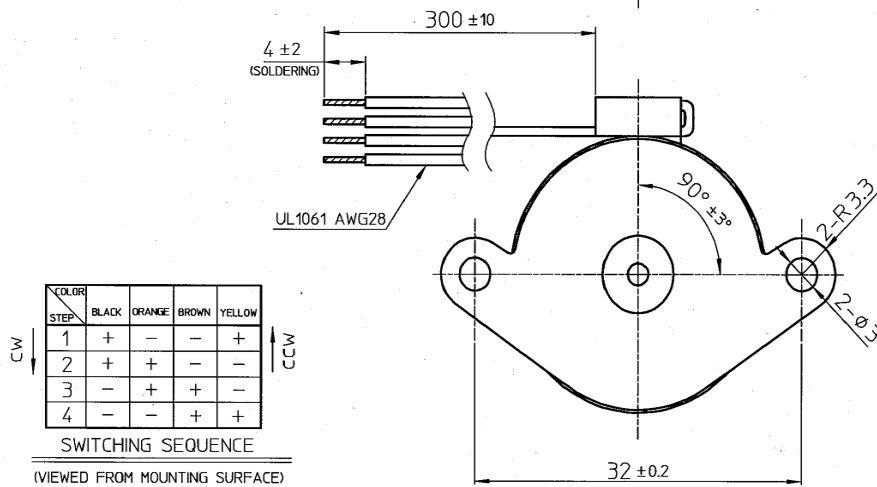



Standard PM Step Motors

PM25L-024-HHC5

DYNAMIC TORQUE CHARACTERISTICS (No. 62790)

(ALL VALUES ARE GAINED BY MEASUREMENT AND NOT SPECIFICATIONS VALUES)

Model : PM25L-024-HHC5
 Drive Mode : BIPOLAR CHOPPER
 Drive Voltage : 24.0 V
 Method : 2-2P
 Drive IC : UDN2917EB
 Surge/Current : / 600 mA / Phase (Peak)
 Coil Resistance : 8.0 Ω
 Magnet Material : MS70A
 Stator Material : SUY/SPC(Ni)

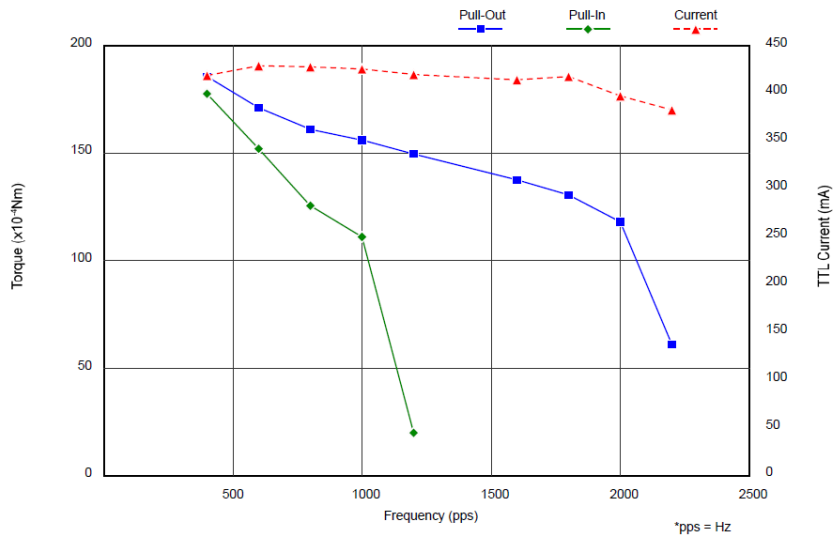

(TTL Current = Over all current drawn by the driver)

Frequency (pps)	400	600	800	1000	1200	1600	1800	2000	2200
■ Pull-Out (x10 ⁻⁴ Nm)	185.4	170.6	160.8	155.9	149.1	137.3	130.4	117.7	60.8
◆ Pull-In (x10 ⁻⁴ Nm)	177.5	152.0	125.5	110.8	19.6				
▲ Current (mA)	418	428	427	425	419	414	417	397	382

Minebea Motor Manufacturing Corporation