

Snap Action Switch

Z

General Purpose Snap Action Switch









- High precision basic switch in a variety of styles
- Wide margins of operating conditions increasing the operating speed range
- Available in general purpose and drip-proof types
- Available in micro-load models







Ordering Information



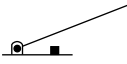









List of Models

Basic Models (General Purpose)

Actuator			Standard		High-sensitivity	Micro load
			G (0.5 mm)		H (0.25 mm)	H (0.25 mm)
Pin plunger		Solder terminal	Z-15G	Z-15H	Z-01H	
		Screw terminal	Z-15G-B	Z-15H-B	Z-01H-B	
Slim spring plunger		Solder terminal	Z-15GS	Z-15HS	Z-01HS	
		Screw terminal	Z-15GS-B	Z-15HS-B	Z-01HS-B	
Short spring plunger		Solder terminal	Z-15GD	Z-15HD	Z-01HD	
		Screw terminal	Z-15GD-B	Z-15HD-B	Z-01HD-B	
Panel mount plunger		Low OP	Solder terminal	Z-15GQ3	—	—
			Screw terminal	Z-15GQ3-B	—	—
		Medium OP	Solder terminal	Z-15GQ	Z-15HQ	Z-01HQ
			Screw terminal	Z-15GQ-B	Z-15HQ-B	Z-01HQ-B
		High OP	Solder terminal	Z-15GQ8	—	—
			Screw terminal	Z-15GQ8-B	—	—
Panel mount roller plunger		Solder terminal	Z-15GQ22	Z-15HQ22	—	
		Screw terminal	Z-15GQ22-B	Z-15HQ22-B	—	
Panel mount cross roller plunger		Solder terminal	Z-15GQ21	Z-15HQ21	—	
		Screw terminal	Z-15GQ21-B	Z-15HQ21-B	—	
Short hinge lever		Solder terminal	Z-15GW21	—	—	
		Screw terminal	Z-15GW21-B	—	—	
Hinge lever		Low OF	Solder terminal	Z-15GW	Z-15HW	—
			Screw terminal	Z-15GW-B	Z-15HW-B	—
		Medium OF	Solder terminal	Z-15GW3	—	—
			Screw terminal	Z-15GW3-B	—	—
		High OF	Solder terminal	Z-15GW32	—	—
			Screw terminal	Z-15GW32-B	—	—
Low-force hinge lever		Solder terminal	Z-15GW4	Z-15HW24	—	
		Screw terminal	Z-15GW4-B	Z-15HW24-B	—	

Actuator			Standard	High-sensitivity	Micro load
			G (0.5 mm)	H (0.25 mm)	H (0.25 mm)
Low-force wire hinge lever 	Low OF	Solder terminal	—	Z-15HW78	—
		Screw terminal		Z-15HW78-B	
	High OF	Solder terminal		Z-15HW52	
		Screw terminal		Z-15HW52-B	
Short hinge roller lever 	Solder terminal	Z-15GW22	Z-15HW22	Z-01HW22	
	Screw terminal	Z-15GW22-B	Z-15HW22-B	Z-01HW22-B	
Hinge roller lever 	Solder terminal	Z-15GW2	Z-15HW2	—	
	Screw terminal	Z-15GW2-B	Z-15HW2-B		
Unidirectional short hinge roller lever 	Solder terminal	Z-15GW2277	—	—	
	Screw terminal	Z-15GW2277-B			

Basic Models (Drip-proof Models)

Actuator			Basic model (drip-proof)	
			Standard G (0.5 mm)	Micro load H (0.25 mm)
				Without drip-proof terminal protective cover
Pin plunger 	Solder terminal	Z-15G55	Z-01H55	
	Screw terminal	Z-15G55-B	Z-01H55-B	
Short spring plunger 	Solder terminal	Z-15GD55	Z-01HD55	
	Screw terminal	Z-15GD55-B	Z-01HD55-B	
Spring plunger 	Medium OP	Solder terminal	Z-15GK55	—
		Screw terminal	Z-15GK55-B	
	High OP	Solder terminal	Z-15GK355	
		Screw terminal	Z-15GK355-B	
Panel mount plunger 	Medium OP	Solder terminal	Z-15GQ55	—
		Screw terminal	Z-15GQ55-B	
Panel mount roller plunger 		Solder terminal	Z-15GQ2255	—
		Screw terminal	Z-15GQ2255-B	
Panel mount cross roller plunger 		Solder terminal	—	—
		Screw terminal	Z-15GQ2155-B	
Short hinge lever 		Solder terminal	Z-15GW2155	—
		Screw terminal	Z-15GW2155-B	
Long hinge lever 		Solder terminal	Z-15GW4455	—
		Screw terminal	Z-15GW4455-B	
Hinge lever 		Solder terminal	Z-15GW55	—
		Screw terminal	Z-15GW55-B	
Short hinge roller lever 		Solder terminal	Z-15GW2255	Z-01HW2255
		Screw terminal	Z-15GW2255-B	Z-01HW2255-B
Hinge roller lever 		Solder terminal	Z-15GW255	—
		Screw terminal	Z-15GW255-B	
Unidirectional short hinge roller lever 		Solder terminal	Z-15GW227755	—
		Screw terminal	Z-15GW227755-B	
Flexible rod (coil spring) (see note 1) 		Solder terminal	Z-15GNJ55	—
		Screw terminal	Z-15GNJ55-B	

Note: The tip is made of resin.

Basic Models (Drip-proof High-sensitivity Models)

Actuator			High-sensitivity	
			H (0.25 mm)	
Flexible rod (steel wire) 	Solder terminal	Z-15HNJS55		
	Screw terminal	Z-15HNJS55-B		

Specifications

■ Characteristics

Item		Basic (except micro load and flexible rod)/ maintained contact Z-15	Basic (micro load) Z-01H	Basic (flexible rod) Z-15
Operating speed (see note)		0.01 mm to 1 m/s (see note 1)		1 mm to 1 m/s
Operating frequency	Mechanical	240 operations/min		120 operations/min
	Electrical	20 operations/min		20 operations/min
Insulation resistance		100 MΩ min. (at 500 VDC)		
Contact resistance		15 mΩ max. (initial value)	15 mΩ max. (initial value)	15 mΩ max. (initial value)
Dielectric strength		Between contacts of same polarity Contact gap G: 1,000 VAC, 50/60 Hz for 1 min Contact gap H: 600 VAC, 50/60 Hz for 1 min Between current-carrying metal parts and ground, and between each terminal and non-current-carrying metal parts 2,000 VAC, 50/60 Hz for 1 min		Between contacts of same polarity Contact gap G: 1,000 VAC, 50/60 Hz for 1 min Contact gap H: 600 VAC, 50/60 Hz for 1 min Between current-carrying metal parts and ground, and between each terminal and non-current-carrying metal parts 2,000 VAC, 50/60 Hz for 1 min
Vibration resistance	Malfunction	10 to 55 Hz, 1.5-mm double amplitude (see note 4)		10 to 20 Hz, 1.5-mm double amplitude (see note 4)
Shock resistance	Destruction	1,000 m/s ² {approx. 100G} max.		1,000 m/s ² {approx. 100G} max.
	Malfunction	300 m/s ² {approx. 30G} max. (see note 2, 4)		50 m/s ² {approx. 5G} max. (see note 4)
Life expectancy	Mechanical	20,000,000 operations min. (see note 3)		1,000,000 operations min.
	Electrical	500,000 operations min.		100,000 operations min.
Degree of protection		General-purpose: IP00 Drip-proof: IP62		
Degree of protection against electric shock		Class I		
Proof tracking index (PTI)		175		
Switch category		D (IEC335-1)		
Ambient temperature		Operating: General-purpose: -25°C to 80°C (with no icing) Drip-proof: -15°C to 80°C (with no icing)		
Ambient humidity		Operating: General-purpose: 35% to 85% Drip-proof: 35% to 95%		
Weight		Approx. 22 to 58 g		Approx. 42 to 48 g

Note: 1. The values are for the plunger models. (For the lever models, the values are at the plunger section.)
(Contact your OMRON representative for other models.)

2. The values are for the Z-15G pin plunger.
3. The values are for the pin plunger. The life expectancy for models other than the pin plunger is 10,000,000 min.
4. Malfunction: 1 ms max.

■ Operating Characteristics — Z Series Accessories (Levers/Plungers)

Characteristics	Model				
	ZAA-1 w/Z-15G-B	ZAA-2 w/Z-15G-B	ZAQ-3 w/Z-15G-B	ZAQ-2 w/Z-15G-B	ZAQ-1 w/Z-15G-B
OF max.	500 g		550 g		
RF min.	170 g		144 g		
PT max.	—		1 mm (0.04 in)		
OT min.	12.7 mm (0.50 in)		4.5 mm (0.18 in)		20.4 mm (0.80 in)
MD max.	2.2 mm (0.09 in)		0.2 mm (0.01 in)		
FP max.	34.5 mm (1.36 in)	46.1 mm (1.81 in)	—		
OP	28.9 ± 1.6 mm (1.14 ± 0.06 in)	40.4 ± 1.6 mm (1.60 ± 0.06 in)	27.8 ± 1.5 mm (1.09 ± 0.06 in)	53.2 ± 1.5 mm (2.09 ± 0.06 in)	69.1 ± 1.5 mm (2.72 ± 0.06 in)

■ Terminal Enclosures — Standard Models

Material	Mounting method	For solder terminal	For screw terminal	Remarks
Phenolic resin	Side mounting	AP-A	AP-B	—
Metal		AP1-A	AP1-B	Use in conjunction with AP-A and AP-B
Polyvinyl chloride		AP-Z	AP-Z	Excels in safety and dust-proofing property

■ Contact Information

Type	Contact gap	Features
General purpose	H: 0.25 mm (high sensitivity)	Pin plunger and lever types available. Drip-proof and flexible rod types are also available.
	G: 0.5 mm (standard)	
Drip-proof	H: 0.25 mm (high sensitivity)	The pin plunger is sealed from the other switch mechanisms by a resilient rubber, and the case and cover are sealed by adhesive so that the switch is resistant to humidity, oil and dust. The degree of protection conforms to IEC IP63.
	G: 0.5 mm (standard)	

■ Ratings

Z-15 (Except Flexible Rod Models)

Item Model	Rated voltage	Non-inductive load				Inductive load			
		Resistive load		Lamp load		Inductive load		Motor load	
		NC	NO	NC	NO	NC	NO	NC	NO
G, H	125 VAC	15 (10) A (see note)		3 A	1.5 A	15 (10) A (see note)		5 A	2.5 A
	250 VAC	15 (10) A (see note)		2.5 A	1.25 A	15 (10) A (see note)		3 A	1.5 A
	500 VAC	10 A		1.5 A	0.75 A	6 A		1.5 A	0.75 A
G	8 VDC	15 A		3 A	1.5 A	15 A		5 A	2.5 A
	14 VDC	15 A		3 A	1.5 A	10 A		5 A	2.5 A
	30 VDC	6 A		3 A	1.5 A	5 A		5 A	2.5 A
	125 VDC	0.5 A		0.5 A	0.5 A	0.05 A		0.05 A	0.05 A
	250 VDC	0.25 A		0.25 A	0.25 A	0.03 A		0.03 A	0.03 A
H	8 VDC	15 A		3 A	1.5 A	15 A		5 A	2.5 A
	14 VDC	15 A		3 A	1.5 A	10 A		5 A	2.5 A
	30 VDC	2 A		2 A	1.4 A	1 A		1 A	1 A
	125 VDC	0.4 A		0.4 A	0.4 A	0.03 A		0.03 A	0.03 A
	250 VDC	0.2 A		0.2 A	0.2 A	0.02 A		0.02 A	0.02 A

Note: Figures in parenthesis are for Z-15HW52 and Z-15HW78(-B) models, the AC ratings of these models are 125 and 250 V only.

Z-15 (Flexible Rod Models)

Rated voltage	Non-inductive load				Inductive load			
	Resistive load		Lamp load		Inductive load		Motor load	
	NC	NO	NC	NO	NC	NO	NC	NO
125 VAC	15 A		2 A	1 A	7 A		2.5 A	2 A
250 VAC	15 A		1 A	0.5 A	5 A		1.5 A	1 A
8 VDC	15 A		2 A	1 A	7 A		3 A	1.5 A
14 VDC	15 A		2 A	1 A	7 A		3 A	1.5 A
30 VDC	2 A		2 A	1 A	1 A		1 A	0.5 A
125 VDC	0.4 A		0.4 A	0.4 A	0.03 A		0.03 A	0.03 A
250 VDC	0.2 A		0.2 A	0.2 A	0.02 A		0.02 A	0.02 A

Z-01H

Rated Voltage	Resistive load	
	NC	NO
125 VAC	0.1 A	
8 VDC	0.1 A	
14 VDC	0.1 A	
30 VDC	0.1 A	

Using Micro Loads

Using a model for ordinary loads to open or close the contact of a micro load circuit may result in faulty contact. Use models that operate in the following range. However, even when using micro load models within the operating range shown here, if inrush current occurs when the contact is opened or closed, it may increase contact wear and so decrease life expectancy. Therefore, insert a contact protection circuit where necessary.

The minimum applicable load is the N-level reference value. This value indicates the malfunction reference level for the reliability level of 60% ($\lambda 60$). The equation, $\lambda 60 = 0.5 \times 10^{-6}/\text{operations}$ indicates that the estimated malfunction rate is less than 1/2,000,000 operations with a reliability level of 60%.

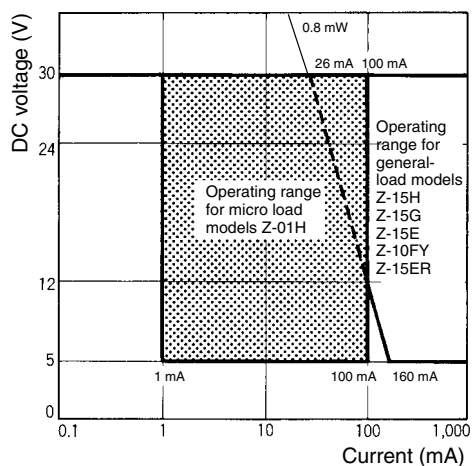

Item	Z-01H	Z-15□, Z-10FY
Minimum applicable load	1 mA at 5 VDC	160 mA at 5 VDC

Contact Form

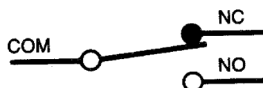

Approval Standards

UL508 (File No. E41515)

CSA C22.2 No.55 (File No. LR21642)

Rated voltage	Z-15	Z-01H
125 VAC	15 A 1/8 HP	0.1 A
250 VAC	15 A 1/4 HP	—
480 VAC	15 A	—
30 VDC	—	0.1 A
125 VDC	0.5 A	—
250 VDC	0.25 A	—

EN (EN61058-1)

Rated voltage	Z-15H□-B	Z-15G□-B	Z-01H□-B
250 VAC	15 A	15 A	—
125 VAC	—	—	0.1 A
30 VDC	—	—	0.1 A

Note: Consult with Omron about approved part numbers by standards.

Drip-proof Construction

Without Terminal Protective Cover

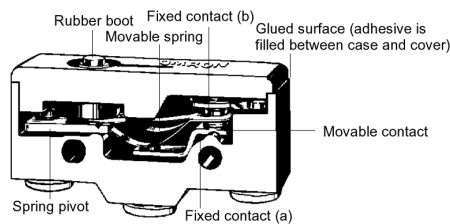

With Terminal Protective Cover

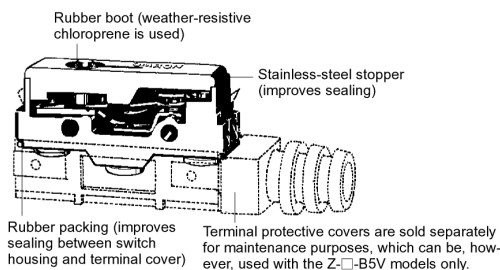

Engineering Data

Mechanical Life Expectancy

Z-15G

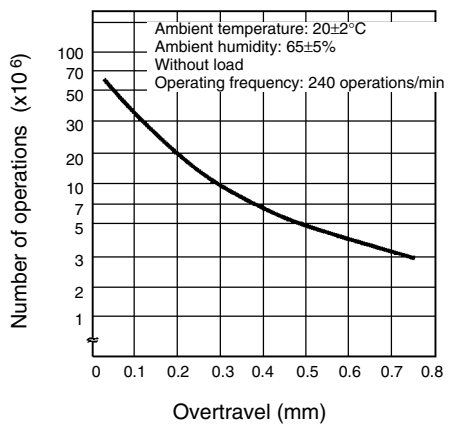

Electrical Life Expectancy

Z-15G

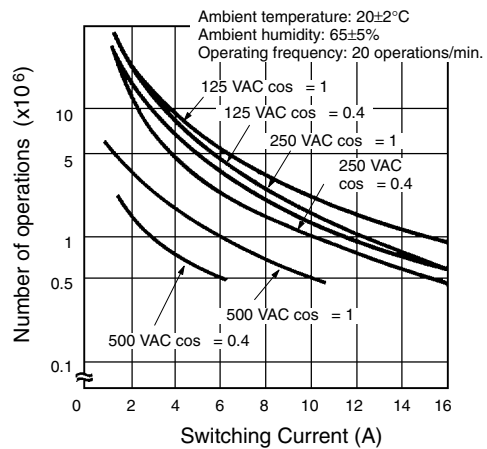

Dimensions

- Note:** 1. All units are in millimeters unless otherwise indicated.
 2. Unless otherwise specified, a tolerance of ± 0.4 mm applies to all dimensions.

Basic Models (General-purpose)

Terminals

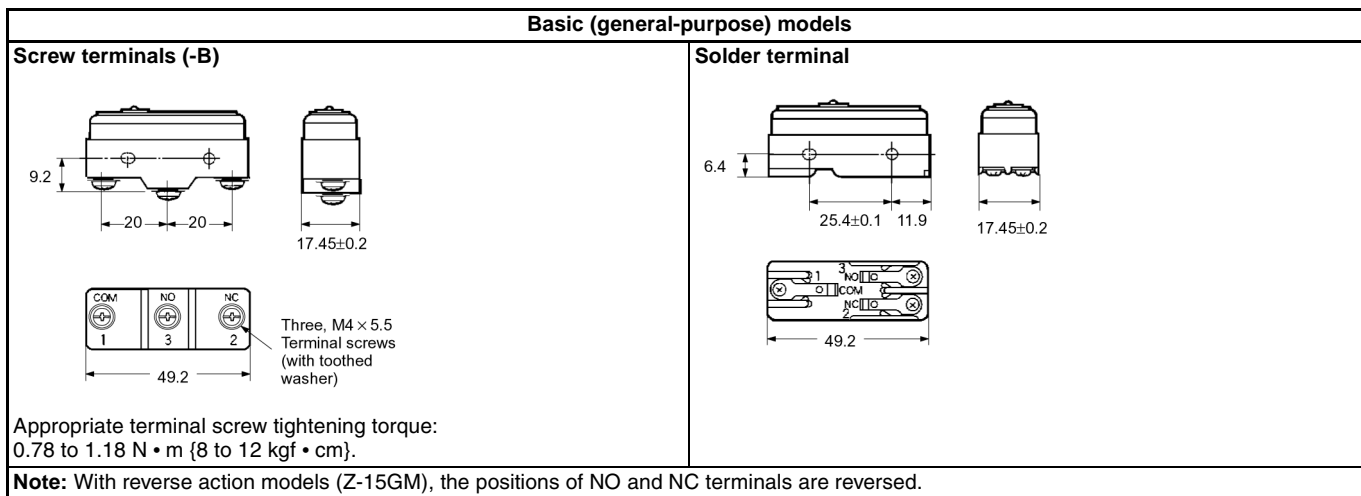

Mounting Holes

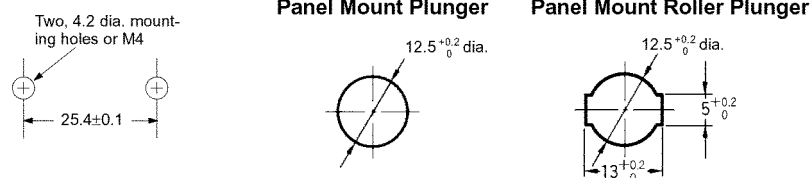

Dimensions and Operating Characteristics

The models, illustrations, and graphics are for screw-terminal models (-B). The “-A” at the end of the model number for solder terminal models has been omitted. For details of the terminals, refer to *Terminals* above.

Pin Plunger

Z-15G-B, Z-15E-B
 Z-15H-B, Z-01H-B

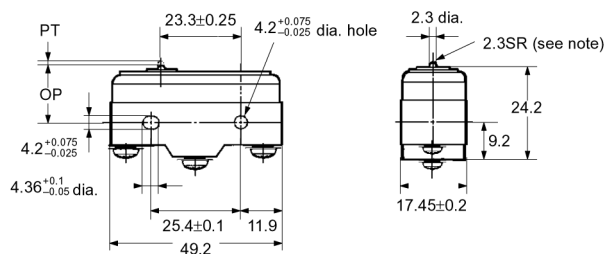

Note: Stainless-steel plunger

	Z-15G-B	Z-15H-B	Z-15E-B	Z-01H-B
OF	2.45 to 3.43 N {250 to 350 gf}	1.96 to 2.75 N {200 to 280 gf}	6.12 to 7.85 N {625 to 800 gf}	2.45 N {250 gf} max.
RF min	1.12 N {114 gf}	1.12 N {114 gf}	1.12 N {114 gf}	0.78 N {80 gf}
PT max.	0.4 mm	0.3 mm	0.8 mm	0.5 mm
OT min.	0.13 mm	0.13 mm	0.13 mm	0.13 mm
MD max.	0.05 mm	0.025 mm	0.13 mm	0.04 mm
OP	15.9 ± 0.4 mm			

Slim Spring Plunger

Z-15GS-B, Z-15HS-B, Z-01HS

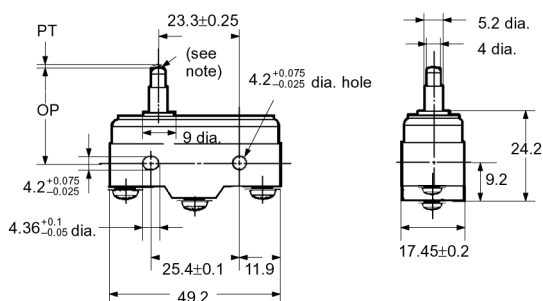
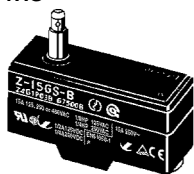

Note: Stainless-steel plunger (flat, 1R chamfered)

	Z-15GS-B	Z-15HS-B	Z-01HS
OF	2.45 to 3.43 N {250 to 350 gf}	1.96 to 2.79 N {200 to 285 gf}	2.45 N {250 gf} max.
RF min	1.12 N {114 gf}	1.12 N {114 gf}	0.78 N {80 gf}
PT max.	0.4 mm	0.3 mm	0.5 mm
OT min.	1.6 mm	1.6 mm	1.6 mm
MD max.	0.05 mm	0.025 mm	0.05 mm
OP	28.2 ± 0.5 mm		

Short Spring Plunger

Z-15GD-B, Z-15HD-B, Z-01HD-B, Z-15ED-B

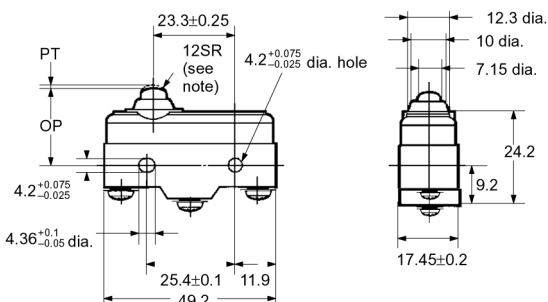
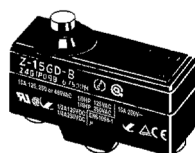

Note: Plated iron plunger

	Z-15GD-B	Z-15HD-B	Z-15ED-B	Z-01HD-B
OF	2.45 to 3.43 N {250 to 350 gf}	1.96 to 2.79 N {200 to 285 gf}	6.13 to 7.85 N {625 to 800 gf}	2.45 N {250 gf} max.
RF min	1.12 N {114 gf}	1.12 N {114 gf}	1.12 N {114 gf}	0.78 N {80 gf}
PT max.	0.4 mm	0.3 mm	0.8 mm	0.5 mm
OT min.	1.6 mm	1.6 mm	1.6 mm	1.6 mm
MD max.	0.05 mm	0.025 mm	0.13 mm	0.05 mm
OP	21.5 ± 0.5 mm			

Panel Mount Plunger

Z-15GQ-B, Z-01HQ-B, Z-15HQ-B, Z-15EQ-B

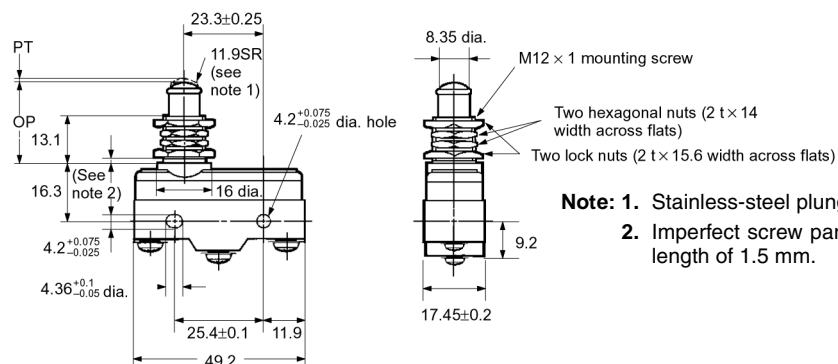
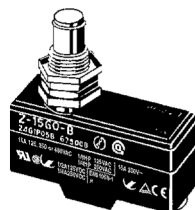

Note: 1. Stainless-steel plunger
2. Imperfect screw part with a maximum length of 1.5 mm.

Z-15GQ3-B

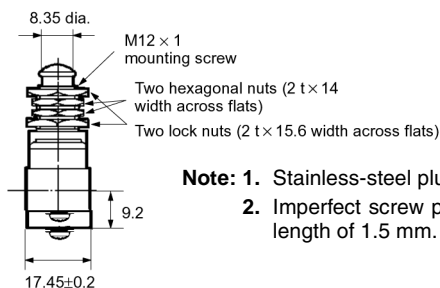
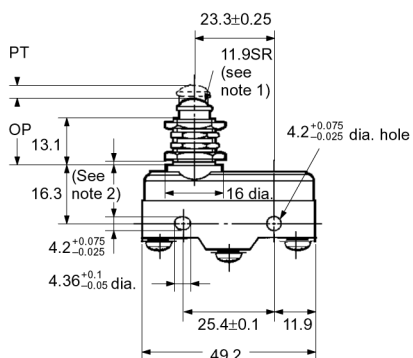
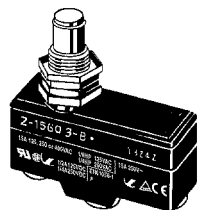

- Note: 1.** Stainless-steel plunger
Note: 2. Imperfect screw part with a maximum length of 1.5 mm.

Z-15GQ8-B

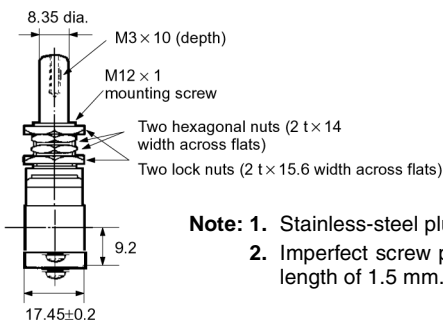
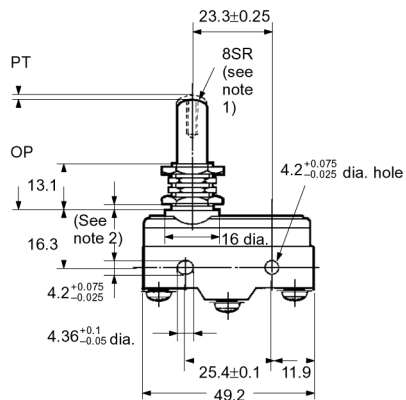
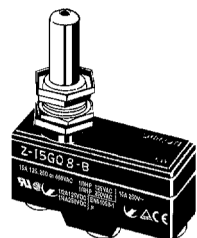

- Note: 1.** Stainless-steel plunger
Note: 2. Imperfect screw part with a maximum length of 1.5 mm.

	Z-15GQ-B	Z-15HQ-B	Z-15EQ-B	Z-01HQ-B	Z-15GQ3-B	Z-15GQ8-B
OF	2.45 to 3.43 N {250 to 350 gf}	1.96 to 2.79 N {200 to 285 gf}	6.13 to 7.85 N {625 to 800 gf}	2.45 N {250 gf} max.	2.45 to 3.43 N {250 to 350 gf}	2.45 to 3.43 N {250 to 350 gf}
RF min	1.12 N {114 gf}	1.12 N {114 gf}	1.12 N {114 gf}	0.78 N {80 gf}	1.12 N {114 gf}	1.12 N {114 gf}
PT max.	0.4 mm	0.3 mm	0.8 mm	0.5 mm	4.2 mm	0.5 mm
OT min.	5.5 mm	5.5 mm	5.5 mm	5.5 mm	2.5 mm	5.5 mm
MD max.	0.05 mm	0.025 mm	0.13 mm	0.05 mm	2.2 mm	0.05 mm
OP	21.8 ± 0.8 mm				18.8 ± 0.8 mm	32.5 ± 1 mm

- Note: 1.** Do not use the M12 mounting screw and the case mounting hole at the same time, or excessive pulling force will be imposed on the Switch and the case and cover may be damaged.
Note: 2. On the model Z-15GQ3-B, PT can be set to a value larger than that for the Z-15GQ.
Note: 3. On the model Z-15GQ8-B, operating position can be adjusted by providing a screw in the plunger section. The M3 hole with a depth of 10 mm is a through hole. Take precautions so that no water or screw lock agent penetrates into the hole.

Panel Mount Roller Plunger

Z-15GQ22-B, Z-15EQ22-B,
Z-15HQ22-B

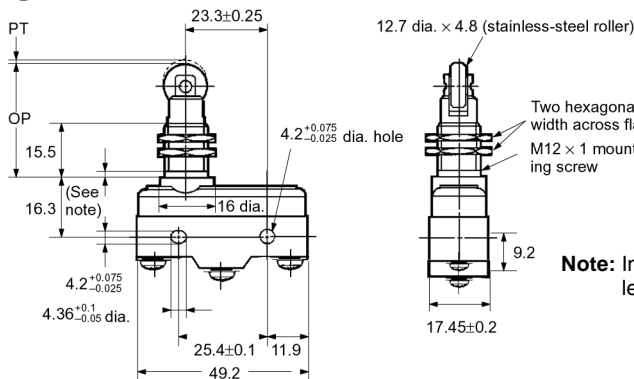
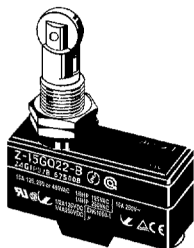

Note: Imperfect screw part with a maximum length of 1.5 mm.

	Z-15GQ22-B	Z-15HQ22-B	Z-15EQ22-B
OF	2.45 to 3.43 N {250 to 350 gf}	1.96 to 2.79 N {200 to 285 gf}	6.13 to 7.85 N {625 to 800 gf}
RF min	1.12 N {114 gf}	1.12 N {114 gf}	1.12 N {114 gf}
PT max.	0.4 mm	0.3 mm	0.8 mm
OT min.	3.58 mm	3.58 mm	3.58 mm
MD max.	0.05 mm	0.025 mm	0.13 mm
OP	33.4 ± 1.2 mm		

Note: Do not use the M12 mounting screw and the case mounting hole at the same time, or the case may be damaged.

Panel Mount Cross Roller Plunger

Z-15GQ21-B, Z-15HQ21-B,
Z-15EQ21-B

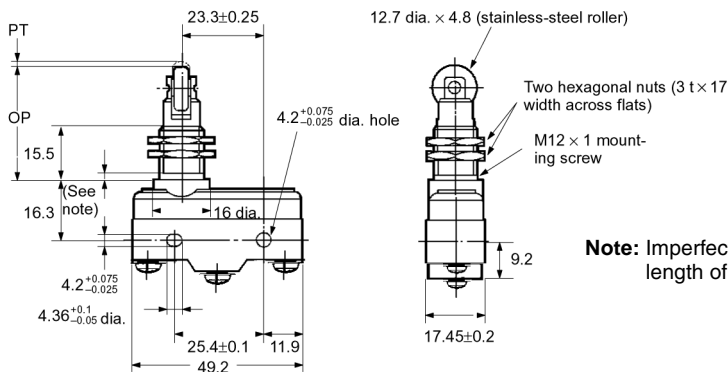
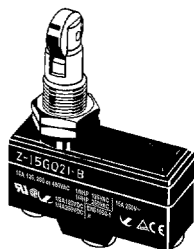

Note: Imperfect screw part with a maximum length of 1.5 mm.

	Z-15GQ21-B	Z-15HQ21-B	Z-15EQ21-B
OF	2.45 to 3.43 N {250 to 350 gf}	1.96 to 2.79 N {200 to 285 gf}	6.13 to 7.85 N {625 to 800 gf}
RF min	1.12 N {114 gf}	1.12 N {114 gf}	1.12 N {114 gf}
PT max.	0.4 mm	0.3 mm	0.8 mm
OT min.	3.58 mm	3.58 mm	3.58 mm
MD max.	0.05 mm	0.025 mm	0.13 mm
OP	33.4 ± 1.2 mm		

Note: Do not use the M12 mounting screw and the case mounting hole at the same time, or the case may be damaged.

Short Hinge Lever

Z-15GW21-B

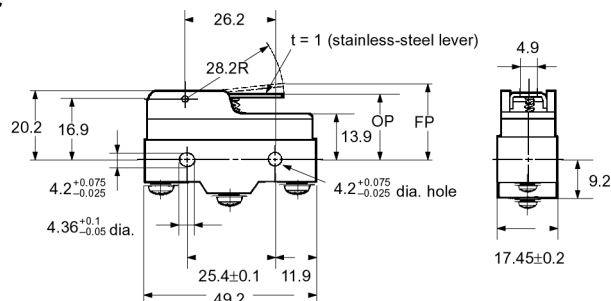

OF max.	1.57 N {160 gf}
RF min.	0.27 N {28 gf}
OT min.	2 mm
MD max.	1 mm
FP max.	24.8 mm
OP	19 ± 0.8 mm

Hinge Lever

Z-15GW-B, Z-15GW32-B,
Z-15HW-B, Z-15GW3-B (Lever length: 56R)
(see note)

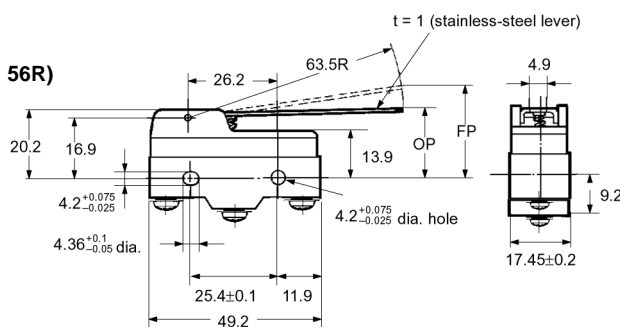
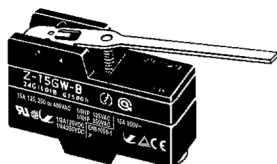

Note: The external dimensions of the actuator vary.

	Z-15GW-B	Z-15HW-B	Z-15GW32-B	Z-15GW3-B
OF max.	0.69 N {70 gf}	0.66 N {67 gf}	1.47 to 1.69 N {150 to 200 gf}	0.78 N {80 gf}
RF min.	0.14 N {14 gf}	0.14 N {14 gf}	0.92 N {94 gf}	0.15 N {15.5 gf}
OT min.	5.6 mm	5.6 mm	5.6 mm	4.8 mm
MD max.	1.27 mm	0.63 mm	1.27 mm	1.12 mm
FP max.	28.2 mm	27.4 mm	28.2 mm	27.2 mm
OP	19 ± 0.8 mm			

Low-force Hinge Lever

Z-15GW4-B

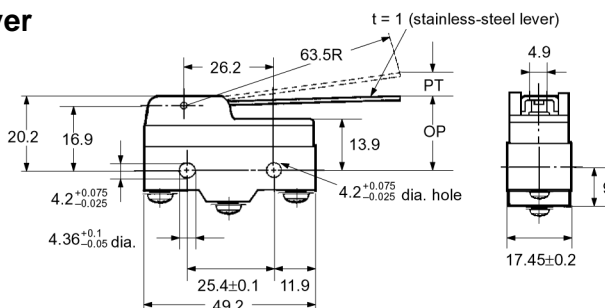
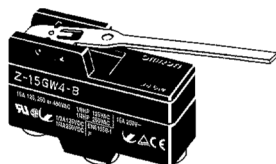

OF max.	274 mN {28 gf}
RF min.	34.3 mN {3.5 gf}
PT max.	10 mm
OT min.	5.6 mm
MD max.	1.27 mm
OP	19 ± 0.8 mm

Z-15HW24-B

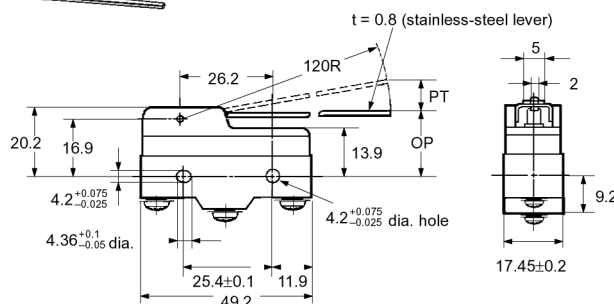
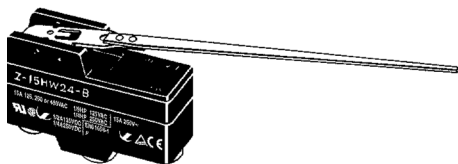

OF max.	58.8 mN {6 gf}
RF min.	4.90 mN {0.5 gf}
PT max.	19.8 mm
OT min.	10 mm
MD max.	2 mm
OP	19.8 ± 1.6 mm

Low-force Wire Hinge Lever

Z-15HW52-B

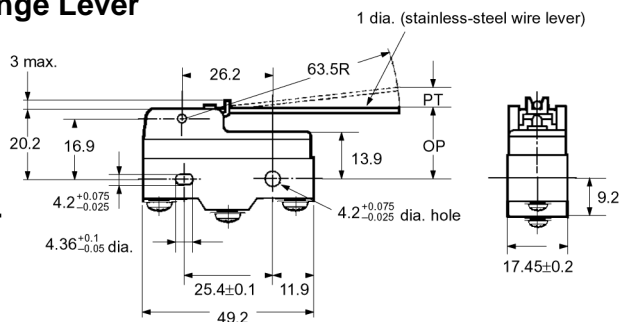
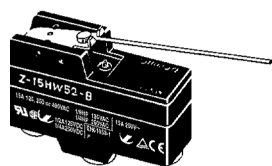

OF max.	58.8 mN {6 gf}
RF min.	4.90 mN {0.5 gf}
PT max.	8.3 mm
OT min.	5.6 mm
MD max.	0.65 mm
OP	19 ± 1 mm

Z-15HW78-B

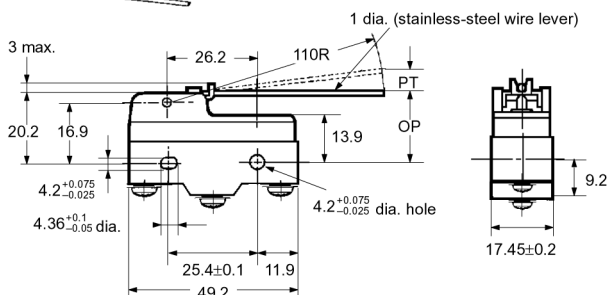
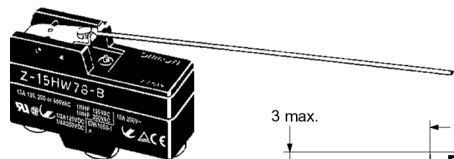

OF max.	39.2 mN {4 gf}
RF min.	2.94 mN {0.3 gf}
PT max.	10 mm
OT min.	6 mm
MD max.	3 mm
OP	20 ± 1 mm

Note: The AC rating is 10 A at 125 or 250 V.

Short Hinge Roller Lever

Z-15GW22-B, Z-01HW22-B
Z-15HW22-B, Z-15EW22-B, Z-15GW2-B
Z-15HW2-B (see note),
(Lever Length: 48.5R) (see note)

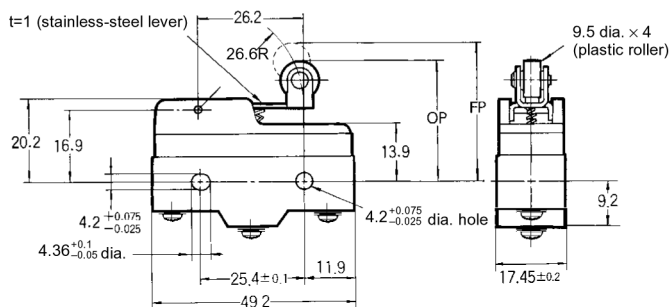

Note: The external dimensions of the actuator vary.

	Z-15GW22-B	Z-15HW22-B	Z-15EW22-B	Z-01HW22-B	Z-15GW2-B	Z-15HW2-B
OF max.	1.57 N {160 gf}	1.47 N {150 gf}	1.94 N {198 gf}	1.57 N {160 gf}	0.98 N {100 gf}	0.84 N {86 gf}
RF min.	0.41 N {42 gf}	0.41 N {42 gf}	0.41 N {42 gf}	0.27 N {28 gf}	0.22 N {22 gf}	0.22 N {22 gf}
OT min.	2.4 mm	2.4 mm	2.4 mm	2.4 mm	4 mm	4 mm
MD max.	0.5 mm	0.45 mm	1.3 mm	0.5 mm	1.02 mm	0.6 mm
FP max.	32.5 mm		35.1 mm	32.5 mm	36.5 mm	
OP	30.2 ± 0.4 mm		30.2 ± 0.4 mm	30.2 ± 0.4 mm	30.2 ± 0.8 mm	

Unidirectional Short Hinge Roller Lever

Z-15GW2277-B

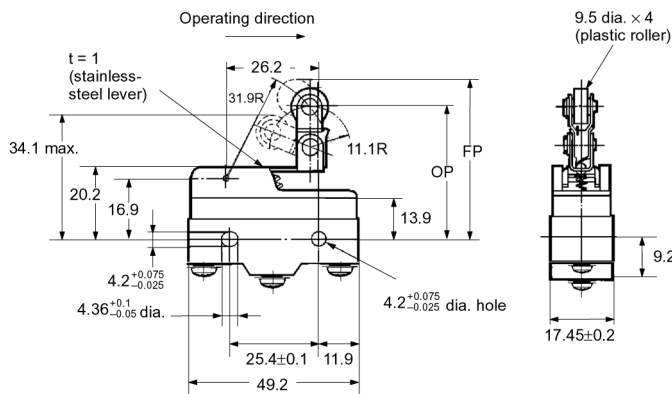
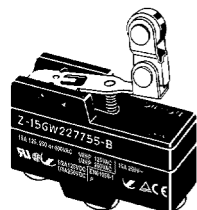

OF max.	1.67 N {170 gf}
RF min.	0.41 N {42 gf}
OT min.	2.4 mm
MD max.	0.51 mm
FP max.	43.6 mm
OP	41.3 ± 0.8 mm

Basic Models (Drip-proof) without Terminal Protective Cover

Terminals

Without Terminal Protective Cover

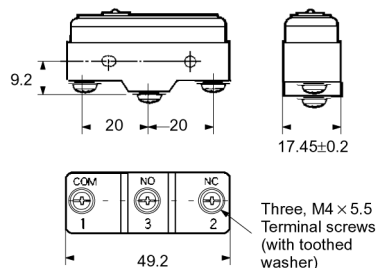

Note: With reverse action models (Z-15GM), the positions of NO and NC terminals are reversed.

Mounting Holes

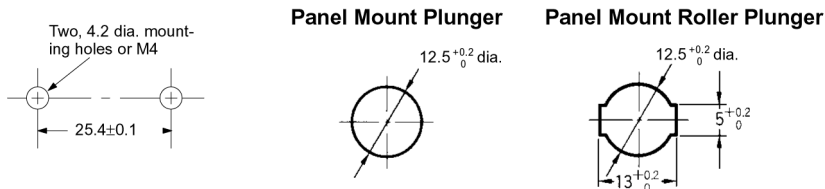

Dimensions and Operating Characteristics

Pin Plunger

Z-15G55-B
Z-01H55-B

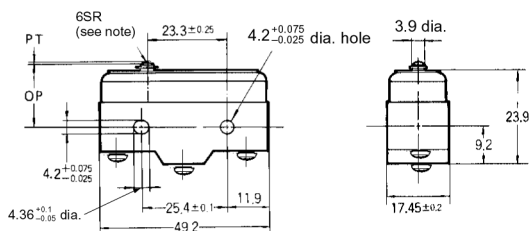
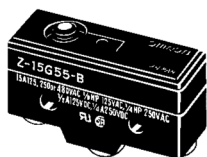

Note: Stainless-steel plunger

Model	Z-15G55-B	Z-01H55-B
OF	2.45 to 4.22 N {250 to 431 gf}	3.43 N {350 gf} max.
RF min.	1.12 N {114 gf}	0.78 N {80 gf}
PT max.	2.2 mm	2.2 mm
OT min.	0.13 mm	0.13 mm
MD max.	0.06 mm	0.06 mm
OP	15.9 ± 0.4 mm	

Short Spring Plunger

Z-15GD55-B
Z-01HD55-B

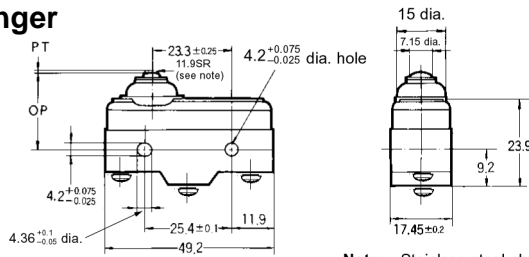
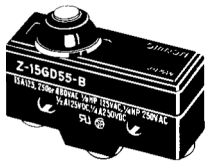

Note: Stainless-steel plunger

Model	Z-15GD55-B	Z-01HD55-B
OF	5.30 N {541 gf}	3.63 N {370 gf}
RF min.	1.12 N {114 gf}	0.78 N {80 gf}
PT max.	1.8 mm	1.9 mm
OT min.	1.6 mm	1.6 mm
MD max.	0.06 mm	0.06 mm
OP	21.5 ± 0.5 mm	

Spring Plunger

Z-15GK55-B

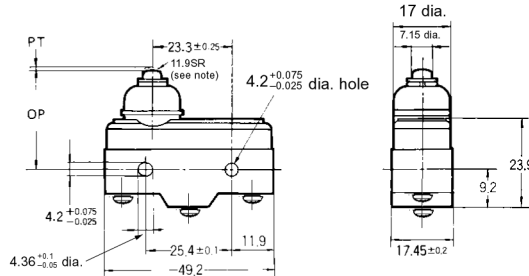
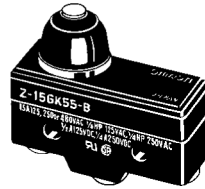

Note: Stainless-steel plunger

OF max.	5.30 N {541 gf}
RF min.	1.12 N {114 gf}
PT max.	2.3 mm
OT min.	1.6 mm
MD max.	0.06 mm
OP	28.2 ± 0.5 mm

Z-15GK355-B

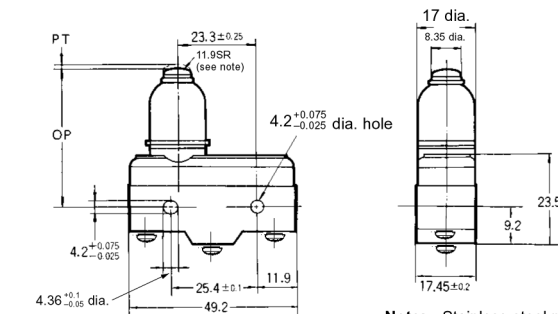
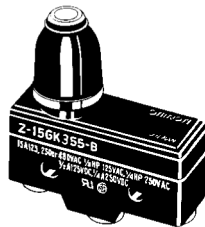

Note: Stainless-steel plunger

OF max.	5.30 N {541 gf}
RF min.	1.12 N {114 gf}
PT max.	2.4 mm
OT min.	3.5 mm
MD max.	0.06 mm
OP	37.8 ± 1.2 mm

Panel Mount Plunger

Z-15GQ55-B

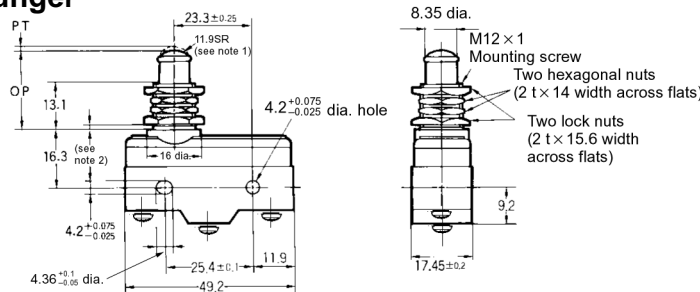
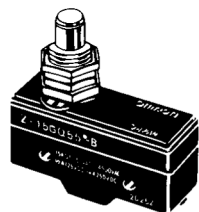

Note: 1. Stainless-steel plunger
2. Imperfect screw part with a maximum length of 1.5 mm.

OF max.	5.30 N {541 gf}
RF min.	1.12 N {114 gf}
PT max.	1.8 mm
OT min.	5.5 mm
MD max.	0.06 mm
OP	21.8 ± 0.8 mm

Note: Do not use the M12 mounting screw and the case mounting hole at the same time, or the case may be damaged.

Panel Mount Roller Plunger

Z-15GQ2255-B

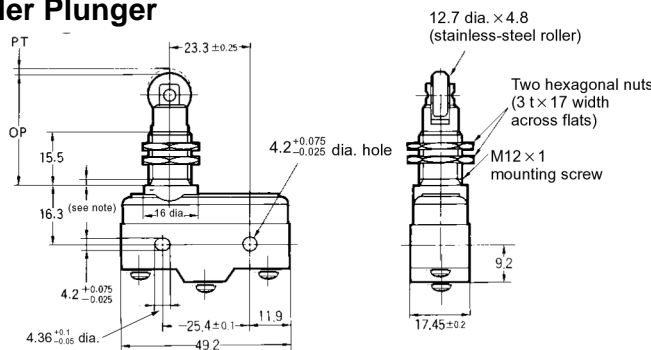
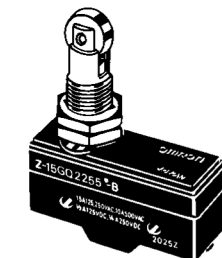

Note: Imperfect screw part with a maximum length of 1.5 mm.

OF max.	5.30 N {541 gf}
RF min.	1.12 N {114 gf}
PT max.	1.8 mm
OT min.	3.58 mm
MD max.	0.06 mm
OP	33.4 ± 1.2 mm

Note: Do not use the M12 mounting screw and the case mounting hole at the same time, or the case may be damaged.

Panel Mount Cross Roller Plunger

Z-15GQ2155-B

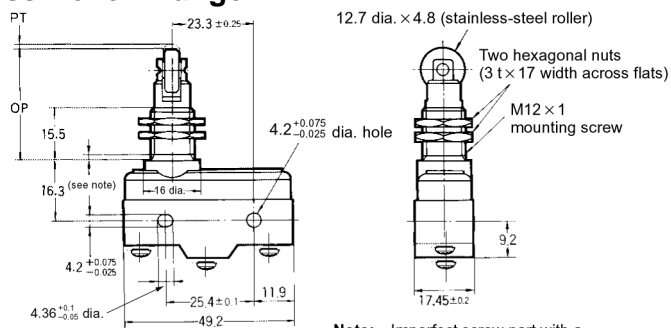
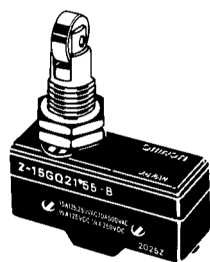

Note: Imperfect screw part with a maximum length of 1.5 mm.

OF max.	5.30 N {541 gf}
RF min.	1.12 N {114 gf}
PT max.	1.8 mm
OT min.	3.58 mm
MD max.	0.06 mm
OP	33.4 ± 1.2 mm

Note: Do not use the M12 mounting screw and the case mounting hole at the same time, or the case may be damaged.

Short Hinge Lever

Z-15GW2155-B

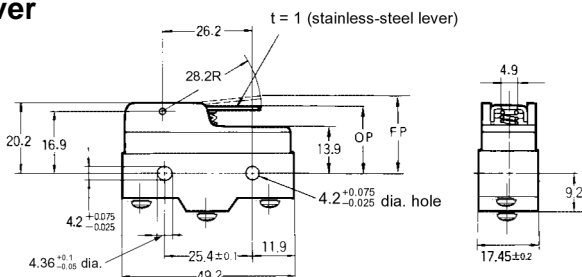
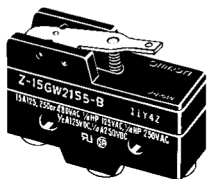

OF max.	1.86 N {190 gf}
RF min.	0.27 N {28 gf}
OT min.	2 mm
MD max.	1 mm
FP max.	25 mm
OP	19 ± 0.8 mm

Long Hinge Lever

Z-15GW4455-B

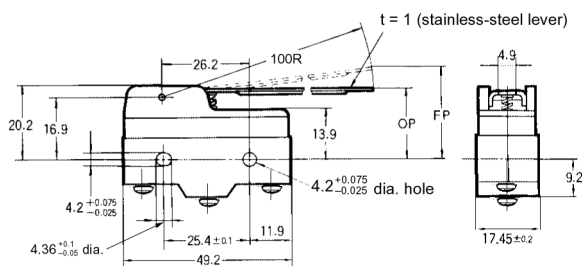
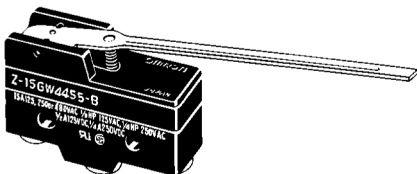

OF max.	0.88 N {90 gf}
RF min.	0.14 N {14 gf}
OT min.	5.6 mm
MD max.	3.5 mm
FP max.	33 mm
OP	19 ± 1.2 mm

Hinge Lever

Z-15GW55-B

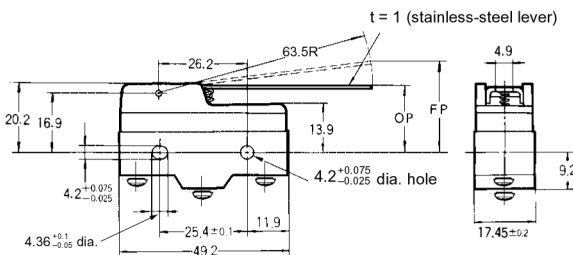
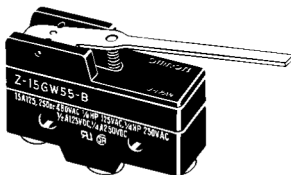

OF max.	0.98 N {100 gf}
RF min.	0.14 N {14 gf}
OT min.	5.6 mm
MD max.	2 mm
FP max.	28.2 mm
OP	19 ± 0.8 mm

Short Hinge Roller Lever

Z-15GW2255-B

Z-01HW2255-B

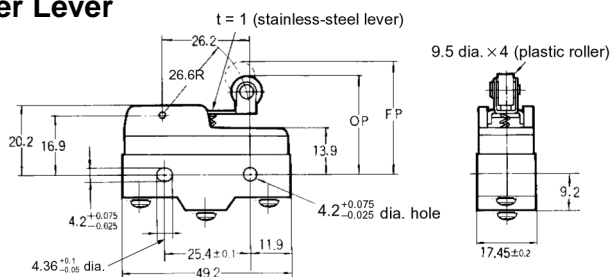
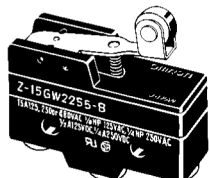

Model	Z-15GW2255-B	Z-01HW2255-B
OF max.	1.96 N {200 gf}	1.96 N {200 gf}
RF min.	0.41 N {42 gf}	0.27 N {28 gf}
OT min.	2.4 mm	2.4 mm
MD max.	0.8 mm	0.8 mm
FP max.	32.9	
OP	30.2 ± 0.4 mm	

Hinge Roller Lever

Z-15GW255-B

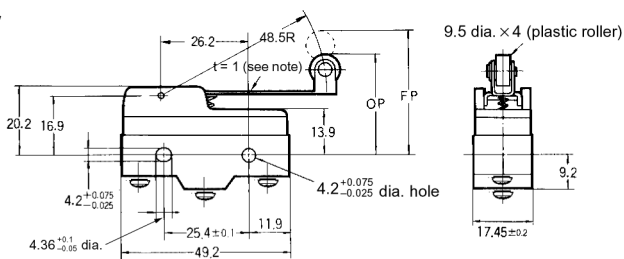
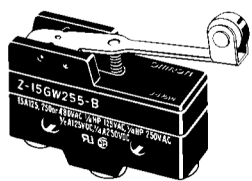

Note: Stainless-steel lever

OF max.	1.27 N {130 gf}
RF min.	0.21 N {21 gf}
OT min.	4 mm
MD max.	1.6 mm
FP max.	36.5 mm
OP	30.2 ± 0.8 mm

Unidirectional Short Hinge Roller Lever

Z-15GW227755-B

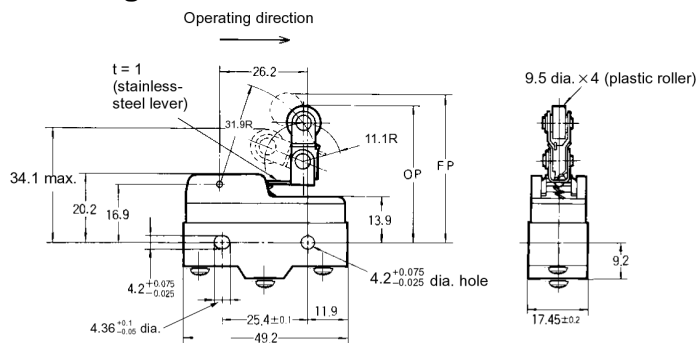
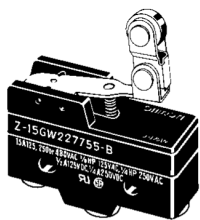

OF max.	1.77 N {181 gf}
RF min.	0.49 N {50 gf}
OT min.	2.4 mm
MD max.	1.8 mm
FP max.	43.6 mm
OP	41.3 ± 0.8 mm

Flexible Rod (Coil Spring)

Z-15GNJ55-B

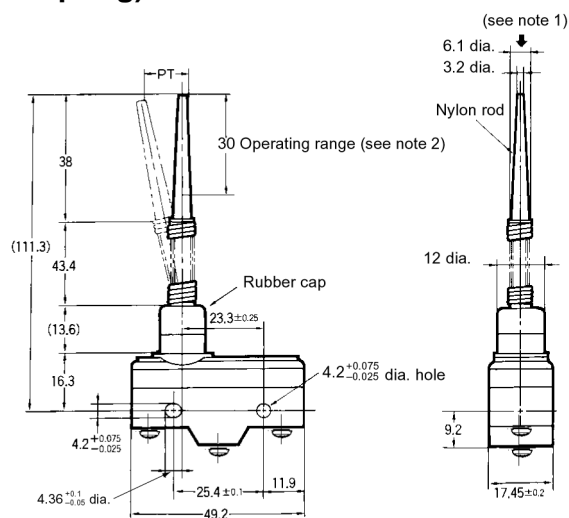
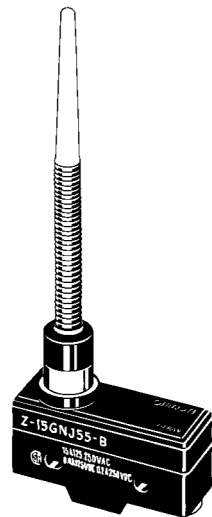

OF max.	0.49 N {50 gf}
PT max.	(20 mm)
OT	42 to 60 mm

Note: 1. Operation is possible in any direction other than the axial direction (indicated by the arrow ↓).

2. Use only the area within the top 30 mm of the rod as the operating part. (Do not use the area that falls within 80 mm from the mounting hole as the operating part. Using this area may cause damage to the nylon rod.)

Flexible Rod (Steel Wire)

Z-15HNJS55-B

OF max.	0.15 N {15 gf}
PT max.	(25 mm)

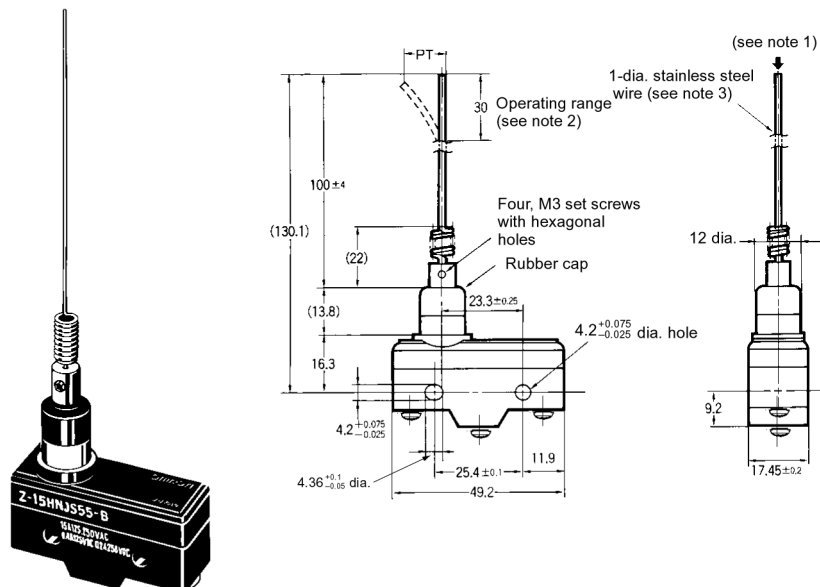

- Note:**
1. Operation is possible in any direction other than the axial direction (indicated by the arrow ↓).
 2. Use only the area within the top 30 mm of the rod as the operating part. (Do not use the area that falls within 100 mm from the mounting hole as the operating part. Using this area may cause damage to the steel wire.)
 3. The steel wire can be replaced if damaged. (Model: Lever for HNJS55)

■ Molded Terminal Type Ordering Information

The solder terminal type can be supplied with molded terminals with a choice of five different lead outlet directions. When placing your order for the molded terminal type, add the following code to the model number.

- M□□
- Lead outlet directions (L, R, D, F, H)
 - Mold thickness (No symbol)...a = 12 mm with VSF
19...a = 19 mm with VCT

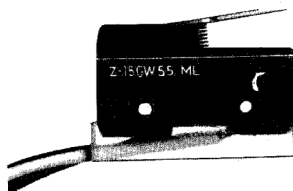

- Note:**
1. Standard leads are single-core vinyl cords (VSF) with a nominal cross sectional area of 1.25 mm².
 2. Standard vinyl cord lengths are 1 m, 3 m, and 5 m.
 3. Mold thickness will be 19 mm when using VCT cords.
 4. Standard unit has three lead outlets in the same direction.
 5. Connect the black lead to the COM terminal, white lead to the NO terminal, and red lead to the NC terminal, respectively.

Directions of Lead Outlets

The following diagrams show the molded terminal version of sealed type Z-15GW2255, with a mold thickness of 12 mm.

Z-15GW2255-ML
(left-hand)

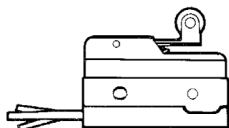

Z-15GW2255-MR
(right-hand)

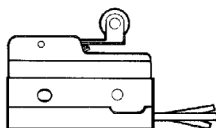

Z-15GW2255-MD
(underside)

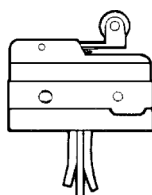

Note: Respective directions of lead outlets are determined with the plunger viewed on your left.

Lead Wire Specifications

Type	Nominal cross-sectional area (mm ²)	Finished outer diameter (mm)	Connection to terminal	Length (m)
VSF (single-core, vinyl cord)	1.25	Approx. 3.1	Black-COM	0.5, 1, 2, 3, 5
VCT (vinyl-insulated cable)		Approx. 9.6 (2-core) Approx. 10.5 (3-core)	White-NO Red-NC	(standard)

Accessories (order separately)

Unit: mm (inch)

Hinge lever
ZAA-1

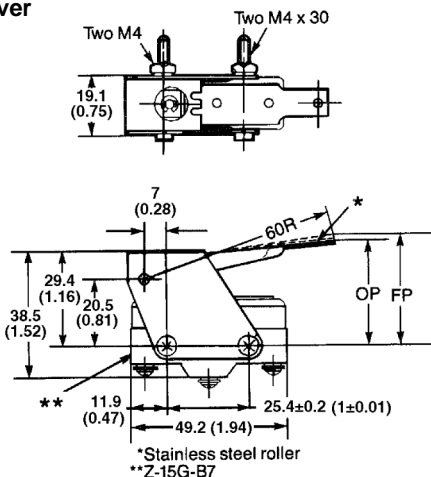

Hinge roller lever
ZAA-2

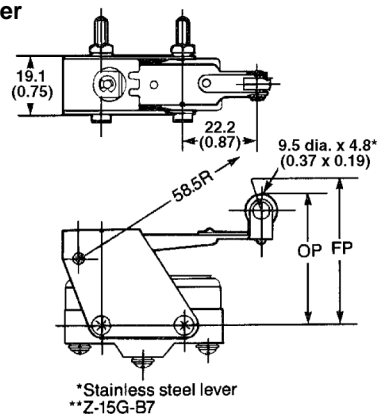

Panel mount plunger
ZAQ-3

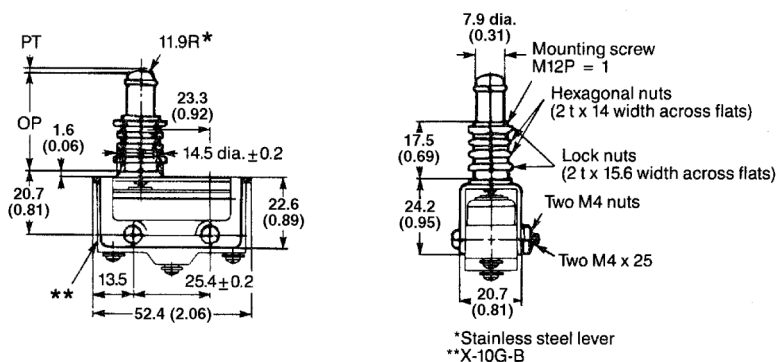

**Panel mount plunger
ZAQ-2**

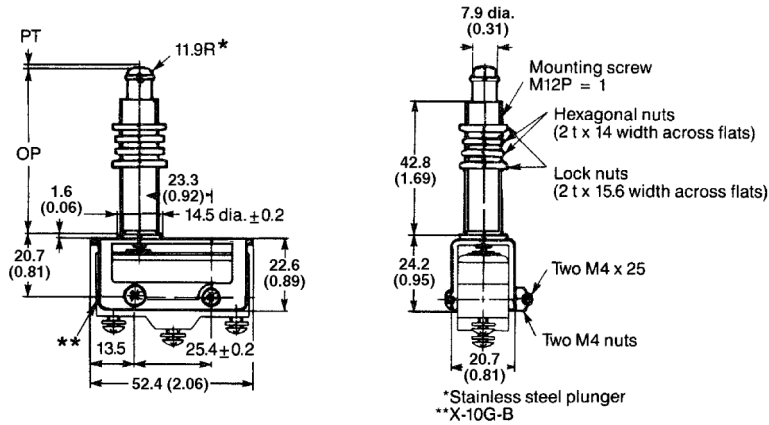

Note: Unless otherwise specified, a tolerance of ± 0.8 mm applies to all dimensions.

**Panel mount plunger
ZAQ-1**

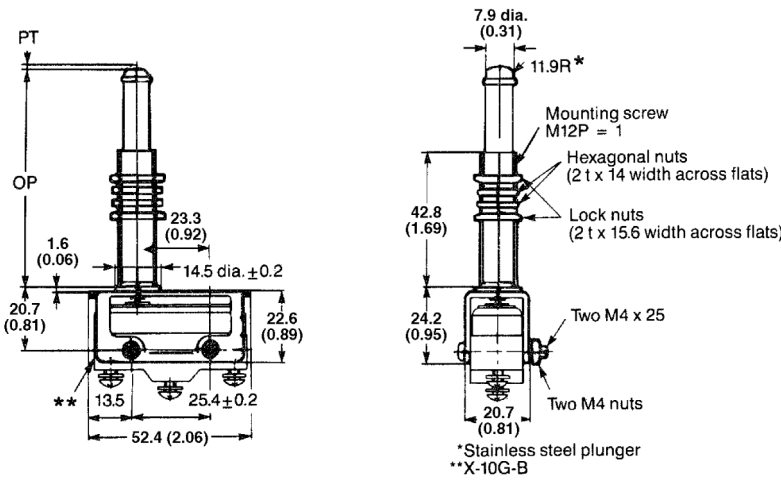

Note: Unless otherwise specified, a tolerance of ± 0.8 mm applies to all dimensions.

AP-A (for solder terminal)

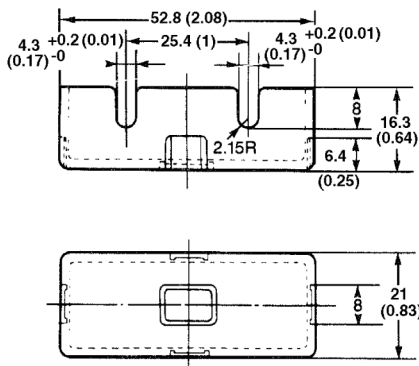

AP1-A (for solder terminal)

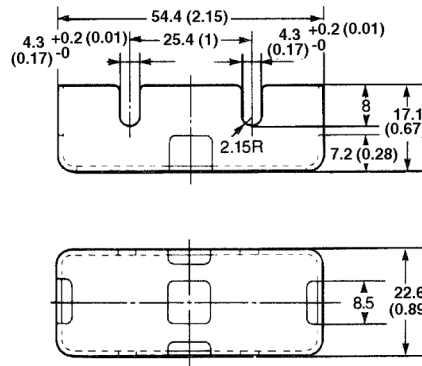

AP-B (for screw terminal)

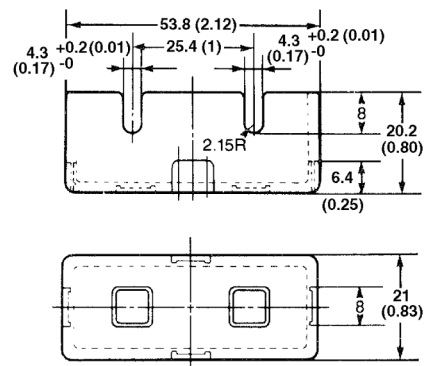

AP1-B

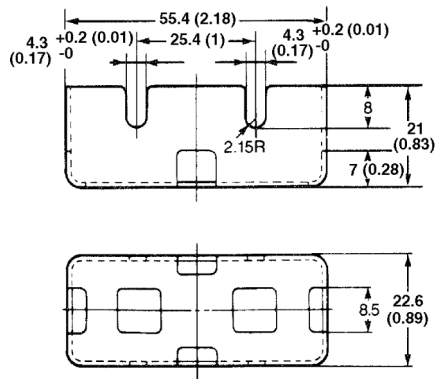

AP-Z

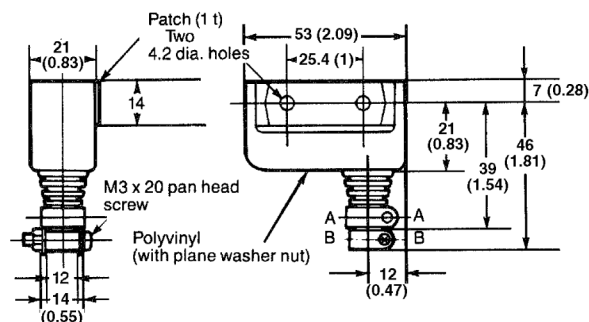

Note: Unless otherwise specified, a tolerance of ± 0.4 mm applies to all dimensions.

■ Cable Outlet Dimensions

A-A section



B-B section

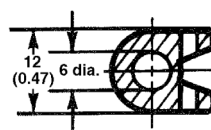

Note: The cable outlet is provided with two stepped openings (6 dia. and 8 dia.) to permit the use of either opening according to the finished OD of the cable to be connected.

Precautions

■ Correct Use

Mounting

Use M4 screws with plane washers and spring washers to mount the Switch. Tighten each mounting screw securely to a torque of 1.18 to 1.47 N • m {12 to 15 kgf • cm}.

Panel Mount Switch (Z-15□Q, Z-01□Q□)

When mounting the panel mount plunger model with screws on a side surface, be careful of the dog angle and operation speed. Excessive dog angle or operation speed may damage the Switch.

The Switch can be panel mounted, provided that the hexagonal nut of the actuator is tightened to a torque of 2.94 to 4.9 N • m {30 to 50 kgf • cm}.

When using the panel mount plunger model mounted with screws on a side surface, be careful not to apply a large shock. Applying a shock exceeding 100G may damage the Switch.

When using the panel mount plunger model mounted with screws on a side surface, remove the hexagonal nuts from the actuator.

High-sensitivity Switch (Z-15H)

When using the Switch in a DC circuit, be sure to provide an arc suppressor as well because the small contact gap of the Switch may result in contact troubles.

In an application where a high repeat accuracy is required, limit the current that flows through the Switch to within 0.1 A. Also, use a relay to control a high-capacity load if the Switch is connected to such a load. (In this case, the exciting current of the relay coil is the load of the Switch.)

Do not apply a force of 19.6 N {2 kgf} or higher to the pin plunger.

Exercise care that the environment conditions such as temperature and humidity do not change abruptly.

Drip-proof Switch (Z-□55)

The Switch is not perfectly oil-tight; so do not dip it in oil or water.

The rubber boots are made from weather-resistant chloroprene rubber.

Do not use Basic Switches in places with radical changes in temperature.

Flexible Rod Switch (Z-15□NJ□55, Drip-proof)

When the rod is fully swung, the Switch may operate when the lever returns, causing chattering. Use a circuit that compensates for chattering wherever possible.

Do not switch the rod to the fullest extent when the Switch is to break a power circuit because such a practice may cause metal deposition to occur between the mating contacts of the Switch.

Others

Do not apply an excessive force to the mounting bracket with a screwdriver or a similar object when attaching or detaching the protective cover; otherwise, the cover will be deformed.

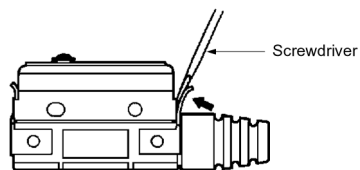

This terminal protective cover cannot be used with models whose model number does not have the prefix “-B5V.”

Terminal protective covers can be ordered separately for maintenance use.

MEMO

A large grid of dashed lines for taking notes, consisting of 20 columns and 30 rows.

Terms and Conditions of Sale

1. Offer; Acceptance. These terms and conditions (these "Terms") are deemed part of all quotations, acknowledgments, invoices, purchase orders and other documents, whether electronic or in writing, relating to the sale of products or services (collectively, the "Products") by Omron Electronic Components LLC ("Seller"). Seller hereby objects to any terms or conditions proposed in Buyer's purchase order or other documents which are inconsistent with, or in addition to, these Terms.
2. Prices; Payment. All prices stated are current, subject to change without notice by Seller. Buyer agrees to pay the price in effect at time of shipment. Payments for Products received are due net 30 days unless otherwise stated in the invoice.
3. Discounts. Cash discounts, if any, will apply only on the net amount of invoices sent to Buyer after deducting transportation charges, taxes and duties, and will be allowed only if (i) the invoice is paid according to Seller's payment terms and (ii) Buyer has no past due amounts owing to Seller.
4. Currencies. If the prices quoted herein are in a currency other than U.S. dollars, Buyer shall make remittance to Seller at the then current exchange rate most favorable to Seller and which is available on the due date; provided that if remittance is not made when due, Buyer will convert the amount to U.S. dollars at the then current exchange rate most favorable to Seller available during the period between the due date and the date remittance is actually made.
5. Governmental Approvals. Buyer shall be responsible for, and shall bear all costs involved in, obtaining any government approvals required for the importation or sale of the Products.
6. Taxes. All taxes, duties and other governmental charges (other than general real property and income taxes), including any interest or penalties thereon, imposed directly or indirectly on Seller or required to be collected directly or indirectly by Seller for the manufacture, production, sale, delivery, importation, consumption or use of the Products sold hereunder (including customs duties and sales, excise, use, turnover and license taxes) shall be charged to and remitted by Buyer to Seller.
7. Financial. If the financial position of Buyer at any time becomes unsatisfactory to Seller, Seller reserves the right to stop shipments or require satisfactory security or payment in advance. If Buyer fails to make payment or otherwise comply with these Terms or any related agreement, Seller may (without liability and in addition to other remedies) cancel any unshipped portion of Products sold hereunder and stop any Products in transit until Buyer pays all amounts, including amounts payable hereunder, whether or not then due, which are owing to it by Buyer. Buyer shall in any event remain liable for all unpaid accounts.
8. Cancellation; Etc. Orders are not subject to rescheduling or cancellation unless Buyer indemnifies Seller fully against all costs or expenses arising in connection therewith.
9. Force Majeure. Seller shall not be liable for any delay or failure in delivery resulting from causes beyond its control, including earthquakes, fires, floods, strikes or other labor disputes, shortage of labor or materials, accidents to machinery, acts of sabotage, riots, delay in or lack of transportation or the requirements of any government authority.
10. Shipping; Delivery. Unless otherwise expressly agreed in writing by Seller:
 1. Shipments shall be by a carrier selected by Seller;
 2. Such carrier shall act as the agent of Buyer and delivery to such carrier shall constitute delivery to Buyer;
 3. All sales and shipments of Products shall be FOB shipping point (unless otherwise stated in writing by Seller), at which point title to and all risk of loss of the Products shall pass from Seller to Buyer, provided that Seller shall retain a security interest in the Products until the full purchase price is paid by Buyer;
 4. Delivery and shipping dates are estimates only.
 5. Seller will package Products as it deems proper for protection against normal handling and extra charges apply to special conditions.
11. Claims. Any claim by Buyer against Seller for shortage or damage to the Products occurring before delivery to the carrier must be presented in writing to Seller within 30 days of receipt of shipment and include the original transportation bill signed by the carrier noting that the carrier received the Products from Seller in the condition claimed.
12. Warranties. (a) Exclusive Warranty. Seller's exclusive warranty is that the Products will be free from defects in materials and workmanship for a period of twelve months from the date of sale by Seller (or such other period expressed in writing by Seller). Seller disclaims all other warranties, express or implied. (b) Limitations. SELLER MAKES NO WARRANTY OR REPRESENTATION, EXPRESS OR IMPLIED, ABOUT NON-INFRINGEMENT, MERCHANTABILITY OR FITNESS FOR A PARTICULAR PURPOSE OF THE PRODUCTS. BUYER ACKNOWLEDGES THAT IT ALONE HAS DETERMINED THAT THE PRODUCTS WILL SUITABLY MEET THE REQUIREMENTS OF THEIR INTENDED USE. Seller further disclaims all warranties and responsibility of any type for claims or expenses based on infringement by the Products or otherwise of any intellectual property right. (c) Buyer Remedy. Seller's sole obligation hereunder shall be to replace (in the form originally shipped with Buyer responsible for labor charges for removal or replacement thereof) the non-complying Product or, at Seller's election, to repay or credit Buyer an amount equal to the purchase price of the Product; provided that in no event shall Seller be responsible for warranty, repair, indemnity or any other claims or expenses regarding the Products unless Seller's analysis confirms that the Products were properly handled, stored, installed and maintained and not subject to contamination, abuse, misuse or inappropriate modification. Return of any Products by Buyer must be approved in writing by Seller before shipment. Seller shall not be liable for the suitability or unsuitability or the results from the use of Products in combination with any electrical or electronic components, circuits, system assemblies, or any other materials or substances or environments. Any advice, recommendations or information given orally or in writing are not to be construed as an amendment to the above warranty.
13. Limitation on Liability; Etc. SELLER SHALL NOT BE LIABLE FOR SPECIAL, INDIRECT, INCIDENTAL OR CONSEQUENTIAL DAMAGES, LOSS OF PROFITS OR PRODUCTION OR COMMERCIAL LOSS IN ANY WAY CONNECTED WITH THE PRODUCTS, WHETHER SUCH CLAIM IS BASED IN CONTRACT, WARRANTY, NEGLIGENCE OR STRICT LIABILITY. Further, in no event shall liability of Seller exceed the individual price of the Product on which liability is asserted.
14. Indemnities. Buyer shall indemnify and hold harmless Seller, its affiliates and its employees from and against all liabilities, losses, claims, costs and expenses (including attorney's fees and expenses) related to any claim, investigation, litigation or proceeding (whether or not Seller is a party) which arises or is alleged to arise from Buyer's acts or omissions under these Terms or in any way with respect to the Products. Without limiting the foregoing, Buyer (at its own expense) shall indemnify and hold harmless Seller and defend or settle any action brought against Seller to the extent that it is based on a claim that any Product made to Buyer specifications infringed intellectual property rights of another party.
15. Property; Confidentiality. The intellectual property embodied in the Products is the exclusive property of Seller and its affiliates and Buyer shall not attempt to duplicate it in any way without the written permission of Seller. Notwithstanding any charges to Buyer for engineering or tooling, all engineering and tooling supplied by Seller to Buyer relating to the Products are confidential and proprietary, and Buyer shall limit distribution thereof to its trusted employees and strictly prevent disclosure to any third party.
16. Miscellaneous. (a) Waiver. No failure or delay by Seller in exercising any right and no course of dealing between Buyer and Seller shall operate as a waiver of rights by Seller. (b) Assignment. Buyer may not assign its rights hereunder without Seller's written consent. (c) Law. These Terms are governed by Illinois law (without regard to conflict of law principles). Federal and state courts in Illinois shall have exclusive jurisdiction for any dispute hereunder. (d) Amendment. These Terms constitute the entire agreement between Buyer and Seller relating to the Products, and no provision may be changed or waived unless in writing signed by the parties. (e) Severability. If any provision hereof is rendered ineffective or invalid, such provision shall not invalidate any other provision. (f) Setoff. Buyer shall have no right to set off any amounts against the amount owing in respect of this invoice. (g) Definitions. As used herein, "including" means "including without limitation".

Certain Precautions on Specifications and Use

1. **Suitability for Use.** Seller shall not be responsible for conformity with any standards, codes or regulations which apply to the combination of the Product in Buyer's application or use of the Product. At Buyer's request, Seller will provide applicable third party certification documents identifying ratings and limitations of use which apply to the Product. This information by itself is not sufficient for a complete determination of the suitability of the Product in combination with the end product, machine, system, or other application or use. Buyer shall be solely responsible for determining appropriateness of the particular Product with respect to Buyer's application, product or system. Buyer shall take application responsibility in all cases but the following is a non-exhaustive list of applications for which particular attention must be given:
 - (i) Outdoor use, uses involving potential chemical contamination or electrical interference, or conditions or uses not described in this document.
 - (ii) Energy control systems, combustion systems, railroad systems, aviation systems, medical equipment, amusement machines, vehicles, safety equipment, and installations subject to separate industry or government regulations.
 - (iii) Use in consumer products or any use in significant quantities.
 - (iv) Systems, machines and equipment that could present a risk to life or property. Please know and observe all prohibitions of use applicable to this product.

NEVER USE THE PRODUCT FOR AN APPLICATION INVOLVING SERIOUS RISK TO LIFE OR PROPERTY WITHOUT ENSURING THAT THE SYSTEM AS A WHOLE HAS BEEN DESIGNED TO ADDRESS THE RISKS, AND THAT THE OMRON PRODUCT IS PROPERLY RATED AND INSTALLED FOR THE INTENDED USE WITHIN THE OVERALL EQUIPMENT OR SYSTEM.
2. **Programmable Products.** Seller shall not be responsible for the user's programming of a programmable product, or any consequence thereof.
3. **Performance Data.** Performance data given in this publication is provided as a guide for the user in determining suitability and does not constitute a warranty. It may represent the result of Seller's test conditions, and the users must correlate it to actual application requirements. Actual performance is subject to Seller's Warranty and Limitations of Liability.
4. **Change in Specifications.** Product specifications and accessories may be changed at any time based on improvements and other reasons. It is our practice to change part numbers when published ratings or features are changed or when significant construction changes are made. However, some specifications of the Product may be changed without any notice. When in doubt, special part numbers may be assigned to fix or establish key specifications for your application. Please consult with your Seller representative at any time to confirm actual specifications of purchased Product.
5. **Errors and Omissions.** The information in this publication has been carefully checked and is believed to be accurate; however, no responsibility is assumed for clerical, typographical or proofreading errors, or omissions.
6. **RoHS Compliance.** Where indicated, our products currently comply, to the best of our knowledge as of the date of this publication, with the requirements of the European Union's Directive on the Restriction of certain Hazardous Substances ("RoHS"), although the requirements of RoHS do not take effect until July 2006. These requirements may be subject to change. Please consult our website for current information.

Complete "Terms and Conditions of Sale" for product purchase and use are on Omron's website at www.components.omron.com – under the "About Us" tab, in the Legal Matters section.

ALL DIMENSIONS SHOWN ARE IN MILLIMETERS.

To convert millimeters into inches, multiply by 0.03937. To convert grams into ounces, multiply by 0.03527.

OMRON®

**OMRON ELECTRONIC
COMPONENTS LLC**

55 E. Commerce Drive, Suite B
Schaumburg, IL 60173

847-882-2288

OMRON CANADA, INC.

885 Milner Avenue
Toronto, Ontario M1B 5V8

416-286-6465

OMRON ON-LINE

Global - <http://www.omron.com>

USA - <http://www.components.omron.com>

Canada - <http://www.omron.ca>