



FSA321 — USB2.0 Hi-Speed (480Mbps) and Audio Switches with Negative Signal Capability and Built-in Termination on Unselected Audio Paths

Features

- Audio: 1.8Ω Typical On Resistance
- HS-USB: 8Ω Typical On Resistance
- HS-USB: 5pF Typical On Capacitance
- USB Path -3db Bandwidth: > 720MHz
- Negative Swing Capable Audio Channel
- Power-off Protection on Common D+/R, D-/L Ports
- Automatic USB Detection (Configurable)
- OVT on all I/O Ports
- Flow-Through Pin Out Eliminates PCB Vias
- Built-In Termination on Unselected Audio Paths to Inhibit Audio Pop

Applications

- MP3, Cell Phone, PDA, Digital Camera, and Notebook
- LCD Monitor, TV, and Set-Top Box

Description

The FSA321 is a Double-Pole, Double Throw (DPDT) multiplexer that combines a low-distortion audio and a USB2.0 High-Speed (HS) switch path. This configuration enables audio and USB data to share a common connector port. The architecture is designed to allow audio signals to swing below ground. This means a common USB and headphone jack can be used for personal media players and portable peripheral devices.

Since USB2.0 is an industry standard for shared data-path in portable devices, FSA321 can be configured for automatic V_{BUS} detection. The FSA321 includes a power-off feature as well as over-voltage tolerance to minimize current consumption when V_{SW} exceeds V_{CC} .

Typical applications involve switching in portables and consumer applications, such as cell phones, digital cameras, and notebooks with hubs or controllers.

Ordering Information

Part Number	Package Number	Top Mark	Package Description
FSA321UMX	MLP010A	GL	10-Lead Quad, Ultrathin Molded Leadless Package (MLP), 1.4 x 1.8mm

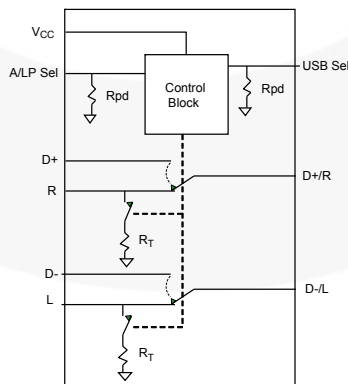

Figure 1. Analog Symbol

Pin Configuration

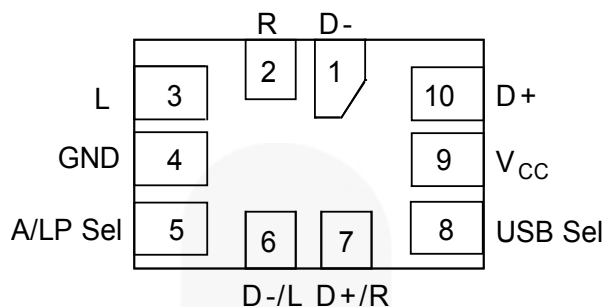

Figure 2. UMLP

Pin Definitions

Pin #	Name	Description
9	V _{CC}	Power supply
5	A/LP Sel	Audio Select Override and Power-Save Mode. This pin can be used to override USB Sel for applications where analog audio is transmitted on the USB D+, D- lines. This same select pin is used to put the FSA321 in low-power mode when USB Sel is LOW, not transmitting audio signals or USB data. The FSA321 has a weak internal pull-down, setting its default state to LOW and allowing this pin to float when not in use.
8	USB Sel	USB Path select pin. Can be connected to USB connector V _{BUS} pin for automatic USB detection.
10, 1	D+, D-	USB data bus input sources
2, 3	R, L	Audio right and left input sources
7, 6	D+/R, D-/L	USB and audio common connector ports

Truth Table

V _{CC}	USB Sel ⁽¹⁾	A/LP Sel	Audio Mode	USB Mode	Remarks
LOW			OFF	OFF	Disabled Inputs High-Z
HIGH ⁽²⁾	HIGH ⁽²⁾	LOW	OFF	ON	USB Communication
HIGH ⁽²⁾	HIGH ⁽²⁾	HIGH ⁽²⁾	ON	OFF	Audio Override on USB
HIGH ⁽²⁾	LOW	HIGH ⁽²⁾	OFF	OFF	Low Power Mode
HIGH ⁽²⁾	LOW	LOW	ON	OFF	Audio Out

Notes:

1. Forcing USB Sel HIGH when V_{BUS} is present allows for automatic USB detection.
2. HIGH is the threshold as defined to meet USB2.0 V_{CC} requirements and audio supply threshold in a system (see DC Tables).

Functional Description

The FSA321 is a combined USB and audio switch that enables sharing the D+/D- lines of a USB connector with stereo audio CODEC outputs. The USB Sel pin has an internal pull-down resistor that results in a default audio-mode configuration. The switch can be configured for auto USB detection by connecting the V_{BUS} pin to the USB Sel pin. The audio switch path also handles negative signals, eliminating the need for large coupling capacitors and greatly reducing the potential for audio pop. Termination resistors on the audio R and L ports

are enabled when the switch is in USB mode, this also helps reduce audio pop when enabling the audio path.

The FSA321 allows for an audio override state by forcing A/LP Sel high when USB Sel is high. This is useful for USB car kit applications or if the device is in a cradle charger when “Send/End” is pressed.

Application Diagram

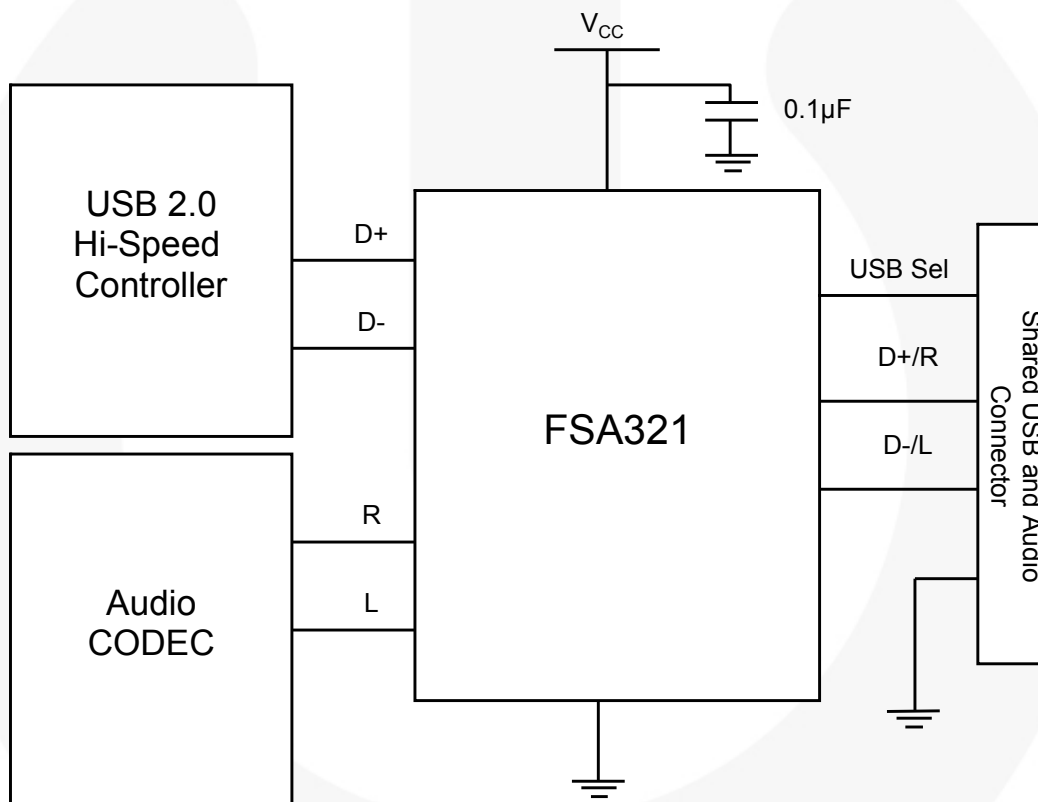

Figure 3. Typical Application Diagram

Absolute Maximum Ratings

Stresses exceeding the absolute maximum ratings may damage the device. The device may not function or be operable above the recommended operating conditions and stressing the parts to these levels is not recommended. In addition, extended exposure to stresses above the recommended operating conditions may affect device reliability. The absolute maximum ratings are stress ratings only.

Symbol	Parameter		Min.	Max.	Unit
V _{CC}	Supply Voltage		-0.5	4.6	V
USB Sel	USB Select Control Signal		-0.5	6.0	V
A/LP Sel	Power Save Mode Control Signal		-0.5	6.0	V
V _{SW}	Switch I/O Voltage ⁽³⁾	USB Path Active	-1.0	4.6	V
		Audio Path Active	V _{CC} -4.6V	4.6	
	DC Switch I/O Voltage ⁽³⁾	USB Path Active	-0.50	5.25	
		Audio Path Active			
I _{IK}	Input Clamp Diode Current			-50	mA
I _{SW}	Switch I/O Current (Continuous)		USB	50	mA
			Audio	100	mA
I _{SWPEAK}	Peak Switch Current (Pulsed at 1ms Duration, <10% Duty Cycle)		USB	100	mA
			Audio	250	mA
T _{STG}	Storage Temperature Range		-65	+150	°C
T _J	Maximum Junction Temperature			+150	°C
T _L	Lead Temperature (Soldering, 10 seconds)			+260	°C
ESD	Human Body Model, JEDEC: JESD22-A114		I/O to GND	11	kV
			All Other Pins	8	
			VCC to GND	12	
	Charged Discharge Model, JEDEC: JESD22-C101		2		
	IEC61000-4-2 System	USB Connection Pins (D+/R, D-/L, V _{BUS})	Air Gap	15	
Contact			8		

Note:

- The input and output negative ratings may be exceeded if the input and output diode current ratings are observed.

Recommended Operating Conditions

The Recommended Operating Conditions table defines the conditions for actual device operation. Recommended operating conditions are specified to ensure optimal performance to the datasheet specifications. Fairchild does not recommend exceeding them or designing to Absolute Maximum Ratings.

Symbol	Parameter		Min.	Max.	Units
V _{CC}	Supply Voltage		1.8	4.3	V
USB Sel	USB Select Control Signal		0	5.5	V
A/LP Sel	Power-Save Mode Control Signal		0	5.5	V
V _{SW}	Switch I/O Voltage	USB Path Active	0	4.3	V
		Audio Path Active	V _{CC} -4.3V	4.3	V
T _A	Operating Temperature		-40	+85	°C
Θ _{JA}	Thermal Resistance (Free Air)	UMLP		284	°C/W

DC Electrical Characteristics

All typical values are at 25°C unless otherwise specified.

Symbol	Parameter	V _{CC} (V)	Conditions	T _A = - 40 to +85°C			Unit
				Min.	Typ. ⁽⁶⁾	Max.	
Common Pins							
V _{IK}	Clamp Diode Voltage	1.8 to 4.3	I _{IK} = -18mA			-1.2	V
V _{IH}	Control Input Voltage HIGH	1.8 to 2.7		1.0			
		2.7 to 4.3		1.2			
V _{IL}	Control Input Voltage LOW	1.8 to 2.7				0.3	
		2.7 to 4.3				0.5	
I _{IN}	USB Sel and A/LP Sel Input Current	1.8 to 4.3	V _{IN} = 0V	-1		1	μA
			V _{IN} = 5.5V	-1		10	
I _{OFF}	Power Off Leakage Current	0	D+/R, D-/L Common Ports, V _{SW} = 0V to 5.5V, All other Pins = 0V			25	μA
R _{PD}	A/LP Sel and USB Sel Internal Pull-Down Resistors	1.8 to 4.3			3		MΩ
R _T	Audio Path Termination Resistors	1.8 to 4.3			200		Ω
USB Switch Path							
	USB Analog Signal Range	1.8 to 4.3		0		4.3	V
R _{ONUSB}	HS Switch On Resistance ⁽⁴⁾	1.8 to 4.3	V _{D+/D-} = 0V, 0.4V, I _{ON} = 8mA		8	11	Ω
ΔR _{ONUSB}	HS Delta R _{ON} ^(5,6)	1.8 to 4.3	V _{D+/D-} = 0V, I _{ON} = 8mA		0.4		Ω
Audio Switch Path							
	Audio Analog Signal Range	1.8 to 4.3		V _{CC-} 4.3V		V _{CC}	V
R _{ONAudio}	Audio Switch On Resistance	2.7	V _{L/R} = -1.0V, 0V, 1.0V I _{ON} = 60mA		1.8	2.7	Ω
ΔR _{ONAudio}	Audio Delta R _{ON} ⁽⁵⁾	2.7 to 4.3	V _{L/R} = 0.7V I _{ON} = 60mA		0.4		Ω
R _{FLAT(Audio)}	Audio R _{ON} Flatness ⁽⁷⁾	2.7 to 4.3	I _{ON} = 60mA		0.8	1.5	Ω
Total Switch Current Consumption							
I _{CC}	USB Active Mode Supply Current	1.8 to 4.3	A/LP Sel = LOW, USB Sel = HIGH, I _{OUT} = 0		0.5	0.8	mA
I _{CC_LPM}	USB Low Power Mode or Audio Mode Quiescent Supply Current	1.8 to 4.3	A/LP Sel = HIGH, V _{CC} = 1.8-4.3V		10	15	μA
I _{CCT}	Increase in I _{CC} current per control voltage and V _{CC} LOW POWER Mode A/LP Sel HIGH	4.3	V _{USB Sel} = 2.6V		10	15	μA
			V _{USB Sel} = 1.8V		15	20	
	Increase in I _{CC} current per control voltage and V _{CC} ACTIVE Mode A/LP Sel LOW		V _{USB Sel} = 2.6V		0.6	0.9	mA
			V _{USB Sel} = 1.8V		0.65	1.00	

Notes:

- On resistance is determined by the voltage drop between the A and B pins at the indicated current through the switch.
- Δ R_{ON} = R_{ON max} – R_{ON min} measured at identical V_{CC}, temperature, and voltage. Worst-case signal path, audio or USB channel, is characterized.
- Guaranteed by characterization, not production tested.
- Flatness is defined as the difference between the maximum and minimum values of on resistance over the specified range of conditions.

AC Electrical Characteristics

All typical value are for $V_{CC} = 3.3V$ at $25^{\circ}C$ unless otherwise specified.

Symbol	Parameter	V_{CC} (V)	Conditions	$T_A = -40$ to $+85^{\circ}C$			Unit
				Min.	Typ. ⁽⁸⁾	Max.	
t_{PDUSB}	USB Switch Propagation Delay ⁽⁸⁾	3.3	$R_L = 50\Omega$, $C_L = 0pF$ Figure 9		0.25		ns
Xtalk _A	Non-Adjacent Channel Crosstalk (Audio Mode)	3.3	$f = 20kHz$, $R_T = 32\Omega$, $C_L = 0pF$, Figure 17		-110		dB
	Non-Adjacent Channel Crosstalk (USB Mode)	3.3	$f = 240MHz$, $R_T = 20\Omega$, $C_L = 0pF$ Figure 17		-45		dB
O _{IRR}	Off Isolation (Audio Mode)	3.3	$f = 20kHz$, $R_T = 32\Omega$, $C_L = 0pF$		-85		dB
	Off Isolation (USB Mode)	3.3	$f = 240MHz$, $R_T = 20\Omega$, $C_L = 0pF$		-40		dB
BW	-3db Bandwidth (USB Mode)	3.3	$R_T = 50\Omega$, $C_L = 0pF$, Signal 0dBm, Figure 15		720		MHz
THD	Total Harmonic Distortion (Audio Mode)	3.3	$f = 20Hz$ to $20kHz$, $R_L = 32\Omega$, $V_{IN} = 2V_{PP}$ Figure 14		0.11		%
SNR	Signal-to-Noise Ratio (Audio Mode)	3.3	$f = 20Hz$ to $20kHz$ $R_L = 32\Omega$, $V_{IN} = 2V_{PP}$		-90		dB

Note:

8. Guaranteed by characterization, not production tested.

USB High-Speed-Related AC Electrical Characteristics

Symbol	Parameter	V _{CC} (V)	Conditions	T _A = - 40°C to +85°C			Unit
				Min.	Typ.	Max.	
t _{SK(O)}	Channel-to-Channel Skew ⁽⁹⁾ (USB Mode)	3.3	t _R = t _F = 750ps (10-90%) at 240MHz C _L = 0pF, R _L = 50Ω Figure 11		35		ps
t _{SK(P)}	Skew of Opposite Transitions of the Same Output ⁽⁹⁾ (USB Mode)	3.3	t _R = t _F = 750ps (10-90%) at 240MHz C _L = 0pF, R _L = 50Ω Figure 10		35		ps
t _J	Total Jitter ⁽⁹⁾ (USB Mode)	3.3	R _L = 50Ω, C _L = 50pF, t _R = t _F = 500ps (10-90%) at 480Mbps (PRBS = 2 ¹⁵ - 1)		130		ps

Note:

9. Guaranteed by characterization, not production tested.

Capacitance

Symbol	Parameter	V _{CC} (V)	Conditions	T _A = - 40°C to +85°C			Unit
				Min.	Typ.	Max.	
C _{IN}	Control Pin Input Capacitance	1.8 to 4.3	V _{Bias} = 0.2V		2.0		pF
C _{ON(D+/R, D-/L)}	D+/R, D-/L On Capacitance (USB Mode)	1.8 to 4.3	V _{Bias} = 0.2V, f = 240MHz, Figure 13		5.4		pF
		1.8 to 5.5	V _{Bias} = 0.2V, f = 1MHz, Figure 13		6.0		pF
C _{OFF(D+, D-)}	USB Path Off Capacitance	1.8 to 4.3	f = 1MHz, Figure 12		1.6		pF
C _{OFF(R/L)}	Audio Path Off Capacitance	1.8 to 4.3	f = 1MHz, Figure 12		3.5		pF

Test Diagrams

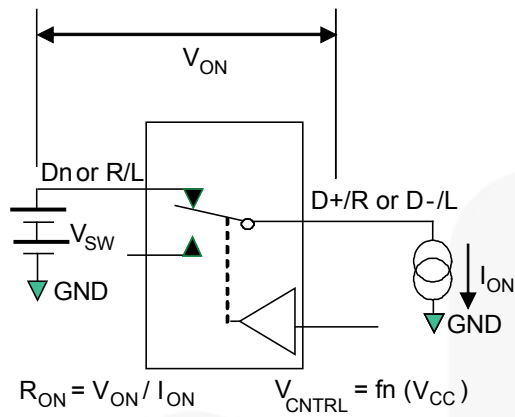

Figure 4. On Resistance

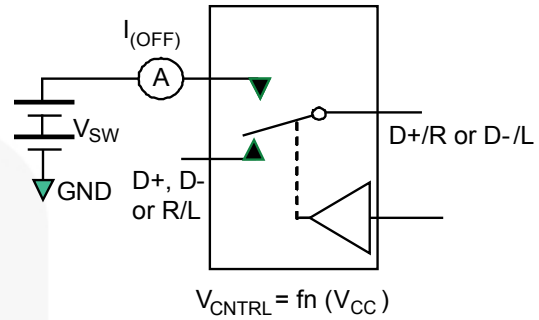

Figure 5. Off Leakage

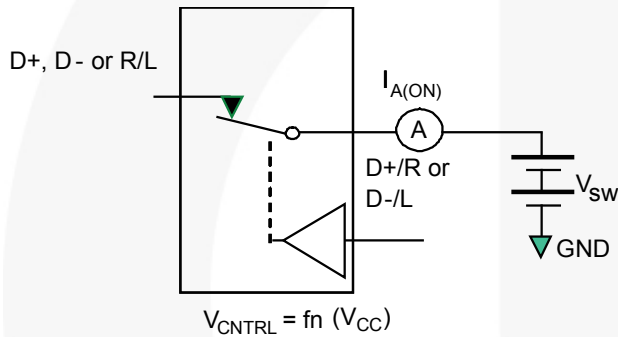

Figure 6. On Leakage

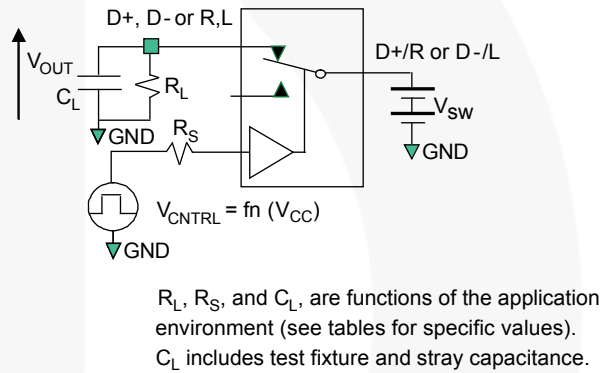

Figure 7. AC Test Circuit Load

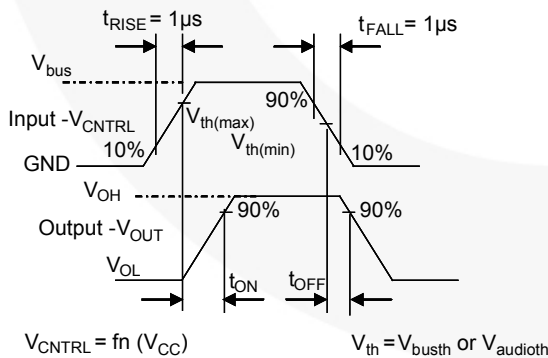

Figure 8. Turn-On / Turn-Off Waveforms (USB/Audio)

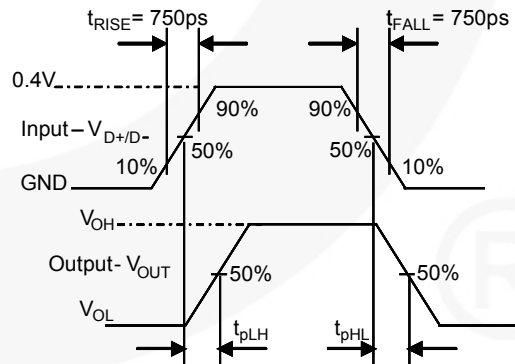

Figure 9. USB Switch Propagation Delay Waveforms

Test Diagrams (Continued)

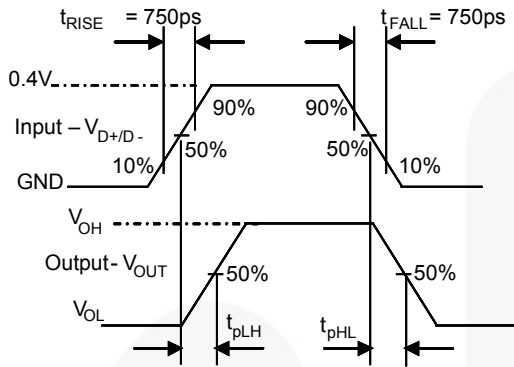

Figure 10. Pulse Skew: $t_{SK(P)} = |t_{pHL} - t_{pLH}|$

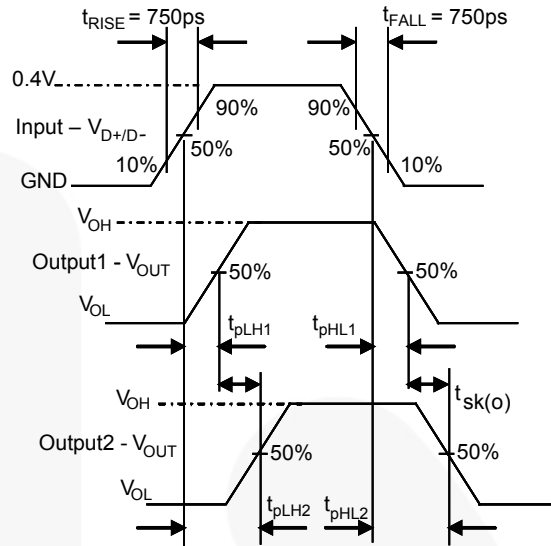

Figure 11. Output Skew: $t_{SK(O)} = |t_{pLH1} - t_{pLH2}|$
or $|t_{pHL1} - t_{pHL2}|$

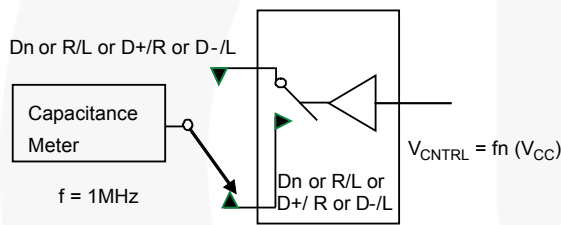

Figure 12. Channel Off Capacitance

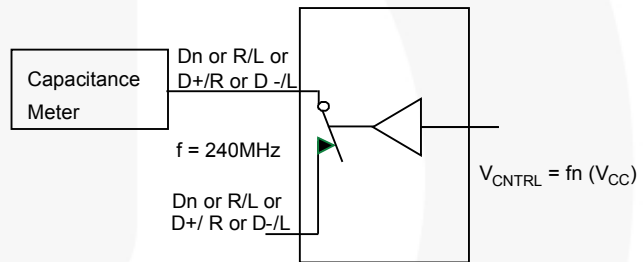

Figure 13. Channel On Capacitance

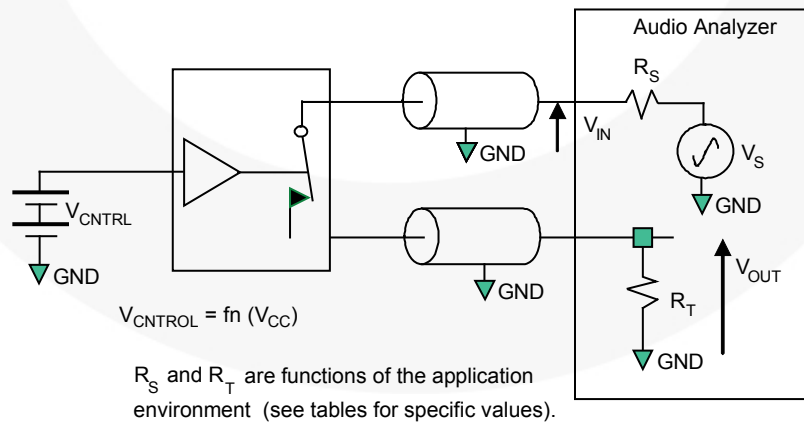

Figure 14. Total Harmonic Distortion

Test Diagrams (Continued)

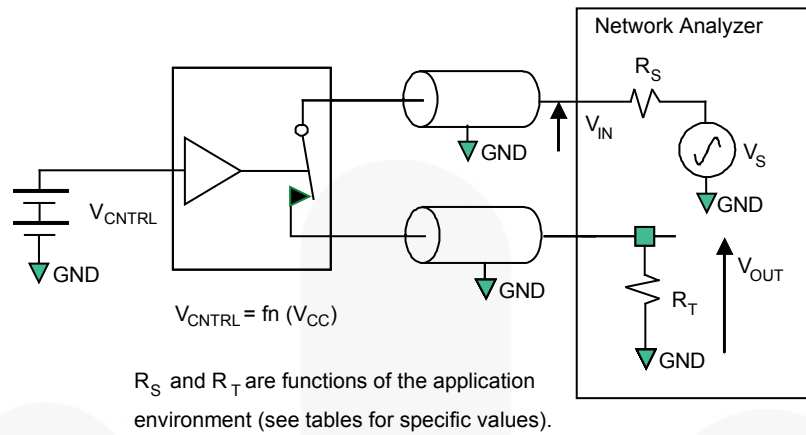

Figure 15. USB Bandwidth

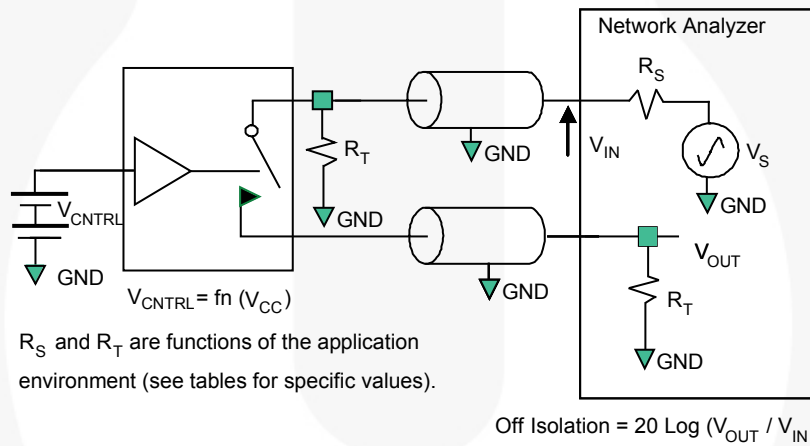

Figure 16. Channel Off Isolation

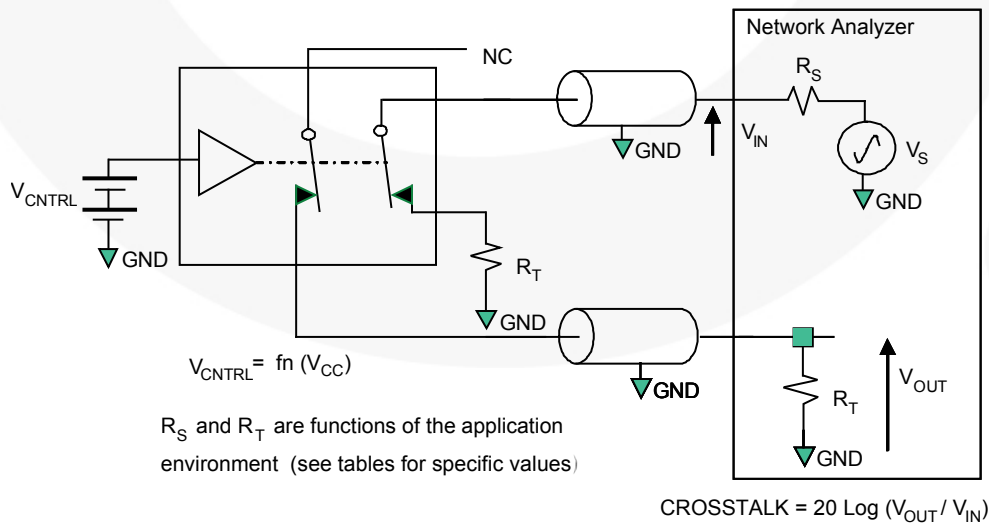
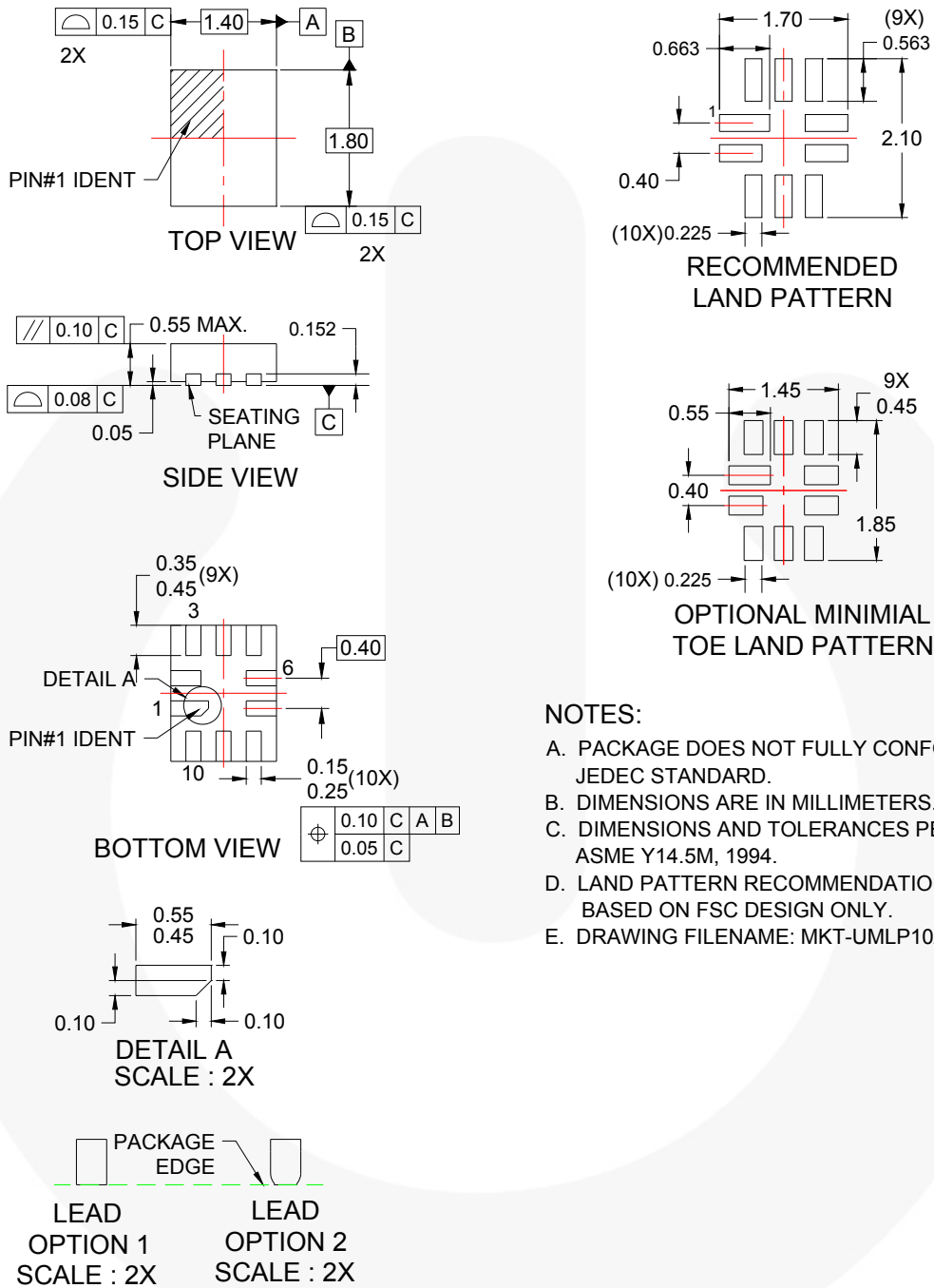

Figure 17. Non-Adjacent Channel-to-Channel Crosstalk

Physical Dimensions



NOTES:

- A. PACKAGE DOES NOT FULLY CONFORM TO JEDEC STANDARD.
- B. DIMENSIONS ARE IN MILLIMETERS.
- C. DIMENSIONS AND TOLERANCES PER ASME Y14.5M, 1994.
- D. LAND PATTERN RECOMMENDATION IS BASED ON FSC DESIGN ONLY.
- E. DRAWING FILENAME: MKT-UMLP10Arev3.

Figure 18. 10-Lead, Quad Ultrathin Molded Leadless Package (UMLP)

Package drawings are provided as a service to customers considering Fairchild components. Drawings may change in any manner without notice. Please note the revision and/or date on the drawing and contact a Fairchild Semiconductor representative to verify or obtain the most recent revision. Package specifications do not expand the terms of Fairchild's worldwide terms and conditions, specifically the warranty therein, which covers Fairchild products.

Always visit Fairchild Semiconductor's online packaging area for the most recent package drawings:

<http://www.fairchildsemi.com/packaging/>



TRADEMARKS

The following includes registered and unregistered trademarks and service marks, owned by Fairchild Semiconductor and/or its global subsidiaries, and is not intended to be an exhaustive list of all such trademarks.

2Cool™
AccuPower™
AX-CAP™*
BitSiC™
Build it Now™
CorePLUS™
CorePOWER™
CROSSVOLT™
CTL™
Current Transfer Logic™
DEUXPEED®
Dual Cool™
EcoSPARK®
EfficientMax™
ESBC™
F®
Fairchild®
Fairchild Semiconductor®
FACT Quiet Series™
FACT®
FAST®
FastvCore™
FETBench™
FlashWriter®*
FPS™

F-PFS™
FRFET®
Global Power Resource™
GreenBridge™
Green FPS™
Green FPS™ e-Series™
Gmax™
GTO™
IntelliMAX™
ISOPLANAR™
Making Small Speakers Sound Louder and Better™
MegaBuck™
MICROCOUPLER™
MicroFET™
MicroPak™
MicroPak2™
MillerDrive™
MotionMax™
Motion-SPM™
mWSaver™
OptoHIT™
OPTOLOGIC®
OPTOPLANAR®

PowerTrench®
PowerXS™
Programmable Active Droop™
QFET®
QS™
Quiet Series™
RapidConfigure™
™
Saving our world, 1mW/kW at a time™
SignalWise™
SmartMax™
SMART START™
Solutions for Your Success™
SPM®
STEALTH™
SuperFET®
SuperSOT™-3
SuperSOT™-6
SuperSOT™-8
SupreMOS®
SyncFET™
Sync-Lock™
 SYSTEM GENERAL®*

The Power Franchise®
the power franchise
TinyBoost™
TinyBuck™
TinyCalc™
TinyLogic®
TINYOPTO™
TinyPower™
TinyPWM™
TinyWire™
TranSiC™
TriFault Detect™
TRUECURRENT®*
 uSerDes™
UHC®
Ultra FRFET™
UniFET™
VCX™
VisualMax™
VoltagePlus™
XS™

* Trademarks of System General Corporation, used under license by Fairchild Semiconductor.

DISCLAIMER

FAIRCHILD SEMICONDUCTOR RESERVES THE RIGHT TO MAKE CHANGES WITHOUT FURTHER NOTICE TO ANY PRODUCTS HEREIN TO IMPROVE RELIABILITY, FUNCTION, OR DESIGN. FAIRCHILD DOES NOT ASSUME ANY LIABILITY ARISING OUT OF THE APPLICATION OR USE OF ANY PRODUCT OR CIRCUIT DESCRIBED HEREIN; NEITHER DOES IT CONVEY ANY LICENSE UNDER ITS PATENT RIGHTS, NOR THE RIGHTS OF OTHERS. THESE SPECIFICATIONS DO NOT EXPAND THE TERMS OF FAIRCHILD'S WORLDWIDE TERMS AND CONDITIONS, SPECIFICALLY THE WARRANTY THEREIN, WHICH COVERS THESE PRODUCTS.

LIFE SUPPORT POLICY

FAIRCHILD'S PRODUCTS ARE NOT AUTHORIZED FOR USE AS CRITICAL COMPONENTS IN LIFE SUPPORT DEVICES OR SYSTEMS WITHOUT THE EXPRESS WRITTEN APPROVAL OF FAIRCHILD SEMICONDUCTOR CORPORATION.

As used herein:

1. Life support devices or systems are devices or systems which, (a) are intended for surgical implant into the body or (b) support or sustain life, and (c) whose failure to perform when properly used in accordance with instructions for use provided in the labeling, can be reasonably expected to result in a significant injury of the user.
2. A critical component in any component of a life support, device, or system whose failure to perform can be reasonably expected to cause the failure of the life support device or system, or to affect its safety or effectiveness.

ANTI-COUNTERFEITING POLICY

Fairchild Semiconductor Corporation's Anti-Counterfeiting Policy. Fairchild's Anti-Counterfeiting Policy is also stated on our external website, www.fairchildsemi.com, under Sales Support.

Counterfeiting of semiconductor parts is a growing problem in the industry. All manufacturers of semiconductor products are experiencing counterfeiting of their parts. Customers who inadvertently purchase counterfeit parts experience many problems such as loss of brand reputation, substandard performance, failed applications, and increased cost of production and manufacturing delays. Fairchild is taking strong measures to protect ourselves and our customers from the proliferation of counterfeit parts. Fairchild strongly encourages customers to purchase Fairchild parts either directly from Fairchild or from Authorized Fairchild Distributors who are listed by country on our web page cited above. Products customers buy either from Fairchild directly or from Authorized Fairchild Distributors are genuine parts, have full traceability, meet Fairchild's quality standards for handling and storage and provide access to Fairchild's full range of up-to-date technical and product information. Fairchild and our Authorized Distributors will stand behind all warranties and will appropriately address any warranty issues that may arise. Fairchild will not provide any warranty coverage or other assistance for parts bought from Unauthorized Sources. Fairchild is committed to combat this global problem and encourage our customers to do their part in stopping this practice by buying direct or from authorized distributors.

PRODUCT STATUS DEFINITIONS

Definition of Terms

Datasheet Identification	Product Status	Definition
Advance Information	Formative / In Design	Datasheet contains the design specifications for product development. Specifications may change in any manner without notice.
Preliminary	First Production	Datasheet contains preliminary data; supplementary data will be published at a later date. Fairchild Semiconductor reserves the right to make changes at any time without notice to improve design.
No Identification Needed	Full Production	Datasheet contains final specifications. Fairchild Semiconductor reserves the right to make changes at any time without notice to improve the design.
Obsolete	Not In Production	Datasheet contains specifications on a product that is discontinued by Fairchild Semiconductor. The datasheet is for reference information only.

Rev. 161