

FSUSB20 — Low-Power, 1-Port, High-Speed USB (480Mbps) Switch

Features

- -30dB Off Isolation: 250MHz
- -30dB Non-adjacent Channel Crosstalk: 250MHz
- On Resistance: 4.5Ω Typical (R_{ON})
- -3dB Bandwidth: >720MHz
- Low-Power Consumption: 1μA Maximum
- Control Input: LVTTTL Compatible
- Bi-Directional Operation
- USB High-Speed and Full-Speed Signaling Capability

Applications

- Cell Phones, PDAs, Digital Cameras, Notebook Computers

Description

FSUSB20 is a low-power, high-bandwidth switch specially designed for switching high-speed USB 2.0 signals in handset and consumer applications; such as cell phone, digital camera, and notebook with hubs or controllers of limited USB I/O. The wide bandwidth (>720MHz) allows signals to pass with minimum edge and phase distortion. Superior channel-to-channel crosstalk results in minimal interference. It is compatible with the high-speed USB 2.0 standard.

Ordering Information

Part Number	Operating Temperature Range	Package	Packing Method
FSUSB20L10X	-40 to +85°C	10-Lead MicroPak™, 1.6 x 2.1mm	Tape and Reel
FSUSB20BQX	-40 to +85°C	14-Terminal Depopulation Quad Very-Thin Flat Pack No Lead (DQFN), JEDEC MO-241, 2.5 X 3.0mm	Tube
FSUSB20MUX	-40 to +85°C	10-Lead Molded Small Outline Package (MSOP), JEDEC MO-187, 3.0mm Wide	Tape and Reel

Connection Diagrams

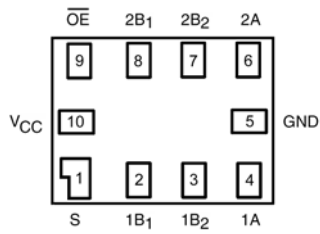

Figure 1. MicroPak™ (Top View)

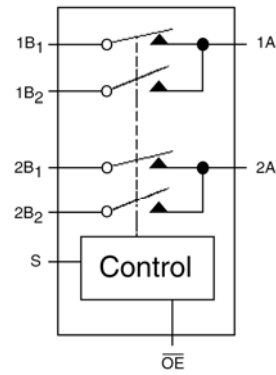

Figure 2. Analog Symbol

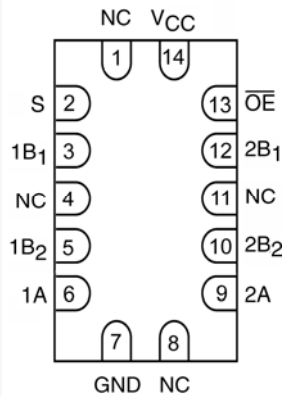

Figure 3. DQFN (Top Through View)

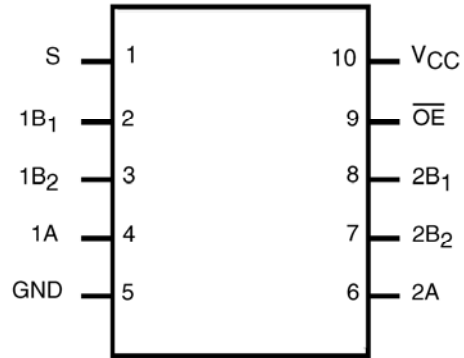

Figure 4. MSOP (Top Through View)

Pin Descriptions

Pin # MicroPak™ / MSOP	Pin # DQFN	Pin Names	Description
1	2	S	Select Input
2, 3, 7, 8	3, 5, 10, 12	1B ₁ , 1B ₂ , 2B ₂ , 2B ₁	Bus B
5	7	GND	Ground
4, 6	6, 9	1A, 2A	Bus A
9	12	OE	Bus Switch Enable
10	14	V _{CC}	Supply Voltage

Truth Table

S	OE	Function
Don't Care	HIGH	Disconnect
LOW	LOW	A=B ₁
HIGH	LOW	A=B ₂

Absolute Maximum Ratings

Stresses exceeding the absolute maximum ratings may damage the device. The device may not function or be operable above the recommended operating conditions and stressing the parts to these levels is not recommended. In addition, extended exposure to stresses above the recommended operating conditions may affect device reliability. The absolute maximum ratings are stress ratings only.

Symbol	Parameter	Min.	Max.	Unit
V_{CC}	Supply Voltage	-0.5	4.6	V
V_S	DC Switch Voltage	-0.5	$V_{CC} + 0.05$	V
V_{IN}	DC Input Voltage ⁽¹⁾	-0.5	4.6	V
I_{IK}	DC Input Diode Current, $V_{IN} < 0V$	-50		mA
I_{OUT}	DC Output Sink Current	50		mA
I_{CC} / I_{GND}	DC V_{CC} / GND Current	± 100		mA
T_{STG}	Storage Temperature Range	-65	+150	°C
ESD	Human Body Model, JESD22-A114	All Pins	7000	V
		I/O to GND	7000	

Note:

- The input and output negative voltage ratings may be exceeded if the input and output diode current ratings are observed.

Recommended Operating Conditions

The Recommended Operating Conditions table defines the conditions for actual device operation. Recommended operating conditions are specified to ensure optimal performance to the datasheet specifications. Fairchild does not recommend exceeding them or designing to Absolute Maximum Ratings.

Symbol	Parameter	Min.	Max.	Unit	
V_{CC}	Power Supply Operating	3.0	3.6	V	
V_{IN}	Input Voltage	0	V_{CC}	V	
V_{OUT}	Output Voltage	0	V_{CC}	V	
t_r, t_f	Input Rise and Fall Time	Switch Control Input ⁽²⁾	0	5	ns/V
		Switch I/O	0	DC	
T_A	Operating Temperature, Free Air	-40	+85	°C	

Note:

- Unused control inputs must be held HIGH or LOW. They may not float.

DC Electrical Characteristics

Typical values are at $V_{CC} = 3.0V$ and $T_A = 25^\circ C$.

Symbol	Parameter	Condition	V_{CC} (V)	$T_A = -40$ to $+85^\circ C$			Unit
				Min.	Typ.	Max.	
V_{IK}	Clamp Diode Voltage	$I_{IN} = -18mA$	3.0			-1.2	V
V_{IH}	High-Level Input Voltage		3.0 to 3.6	2.0			V
V_{IL}	Low-Level Input Voltage		3.0 to 3.6			0.8	V
I_{IN}	Input Leakage Current	$0 \leq V_{IN} \leq 3.6V$	3.6			± 1.0	μA
I_{OFF}	Off-State Leakage Current	$0 \leq A, B \leq V_{CC}$	3.6			± 1.0	μA
R_{ON}	Switch On Resistance ⁽³⁾	$V_{IN} = 0.8V, I_{ON} = 8mA$	3.0		5	7	Ω
		$V_{IN} = 3.0V, I_{ON} = 8mA$	3.0		4.5	6.5	
ΔR_{ON}	Delta R_{ON}	$V_{IN} = 0.8V, V_{IN} = 0V - 1.5V,$ $I_{ON} = 8mA$	3.0		0.3		Ω
$R_{FLAT(ON)}$	On Resistance Flatness ⁽⁴⁾	$I_{OUT} = 8mA$	3.0		1		Ω
I_{CC}	Quiescent Supply Current	$V_{IN} = V_{CC}$ or GND, $I_{OUT} = 0$	3.6			1	μA

Notes:

3. Measured by the voltage drop between the A and B pins at the indicated current through the switch. On resistance is determined by the lower of the voltages on the A or B pins.
4. Flatness is defines as the difference between the maximum and the minimum value on resistance over the specified range of conditions.

AC Electrical Characteristics

Typical values are at $V_{CC} = 3.3V$ and $T_A = 25^{\circ}C$.

Symbol	Parameter	Condition	$V_{CC}(V)$	Typ.	Max.	Unit	Figure
t_{ON}	Turn-On Time S-to-Bus B	$V_B = 0.8V$	3.0 to 3.6	4.8	7.0	ns	Figure 9 Figure 10
t_{OFF}	Turn-Off Time S-to-Bus B	$V_B = 0.8V$	3.0 to 3.6	2.2	4.0	ns	Figure 9 Figure 10
t_{PD}	Propagation Delay	$C_L = 10pF$	3.0 to 3.6	0.25		ns	Figure 14
O_{IRR}	Non-Adjacent Off Isolation	$f = 250MHz,$ $R_L = 50\Omega$	3.0 to 3.6	-26		dB	Figure 11
X_{TALK}	Non-Adjacent Channel Crosstalk	$f = 250MHz,$ $R_L = 50\Omega$	3.0 to 3.6	-45		dB	Figure 12
BW	-3dB Bandwidth	$R_L = 50\Omega, C_L = 0pF$	3.0 to 3.6	750		MHz	Figure 13
		$R_L = 50\Omega, C_L = 5pF$		435			

USB Related AC Electrical Characteristics

Typical values are at $V_{CC} = 3.3V$ and $T_A = 25^{\circ}C$.

Symbol	Parameter	Condition	$V_{CC} (V)$	Typ.	Unit	Figure
$t_{SK(O)}$	Channel-to Channel Skew	$C_L = 10pF$	3.0 to 3.6	0.051	ns	Figure 14 Figure 16
$t_{SK(P)}$	Skew of Opposite Transition of the Same Output	$C_L = 10pF$	3.0 to 3.6	0.020	ns	Figure 14 Figure 16
T_J	Total Jitter	$R_L = 50\Omega, C_L = 10pF$ $t_R = t_F = 750ps$ at 480MPs	3.0 to 3.6	0.170	ns	

Capacitance

Typical values are at $V_{CC} = 3.3V$ and $T_A = 25^{\circ}C$.

Symbol	Parameter	Condition	Typ.	Unit
C_{IN}	Control Pin Input Capacitance	$V_{CC} = 0V$	2.5	pF
C_{ON}	A/B On Capacitance	$V_{CC} = 3.3V, /OE = 0V$	12.0	pF
C_{OFF}	Port B Off Capacitance	V_{CC} and $/OE = 3.3V$	4.5	pF

Performance Characteristics

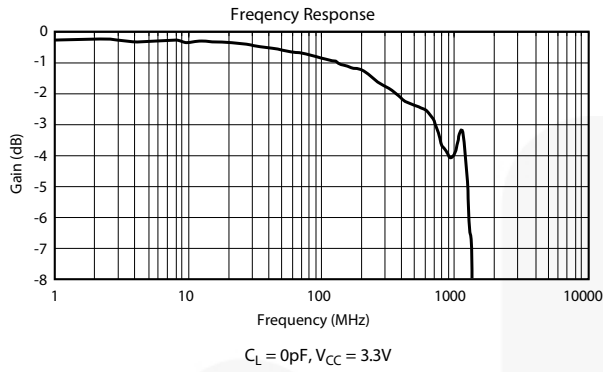

Figure 5. Gain vs. Frequency

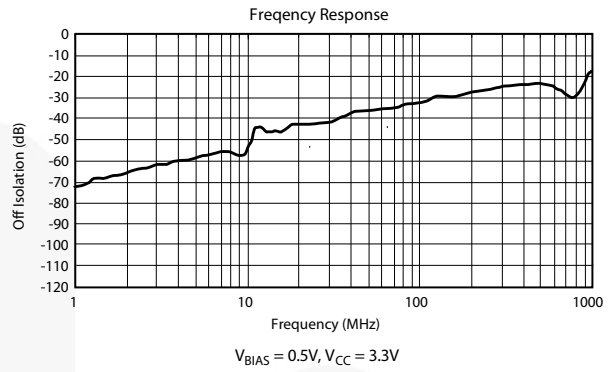

Figure 6. Off Isolation

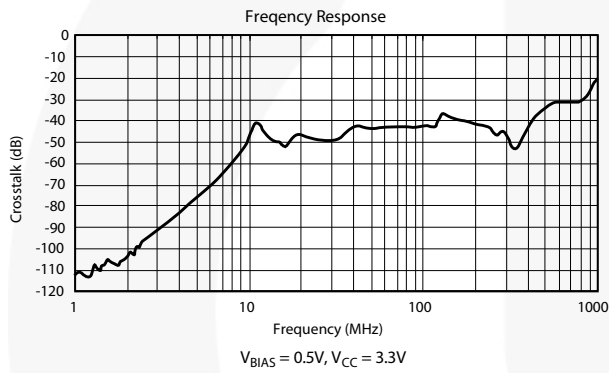

Figure 7. Crosstalk

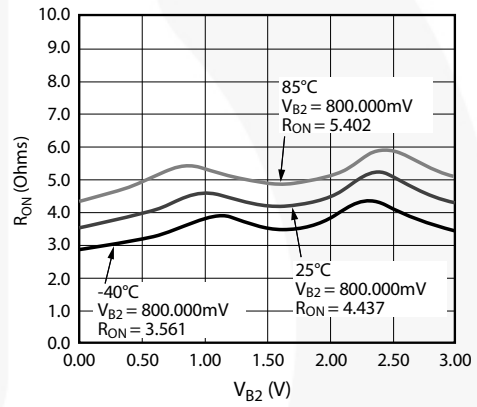
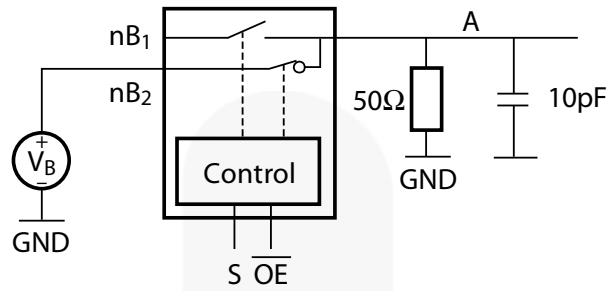

Figure 8. R_{ON}

AC Loadings and Waveforms



Notes: Input driven by 50Ω source terminated in 50Ω.
 C_L includes load and stray capacitance.
 Input PRR-1.0MHz, $t_w = 500ns$.

Figure 9. AC Test Circuit

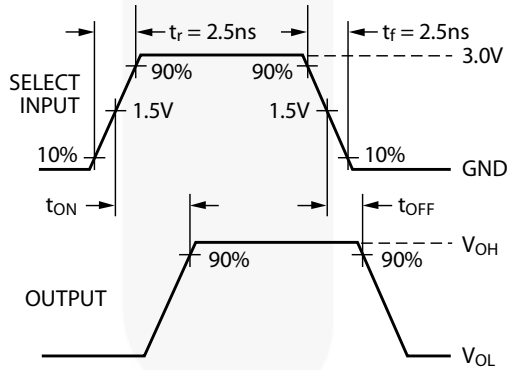

Figure 10. AC Waveforms

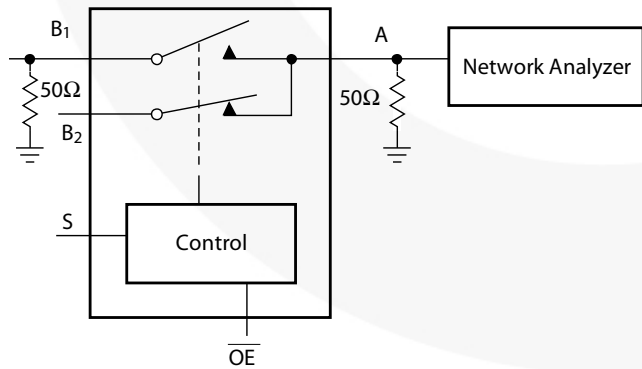

Figure 11. Off Isolation Test

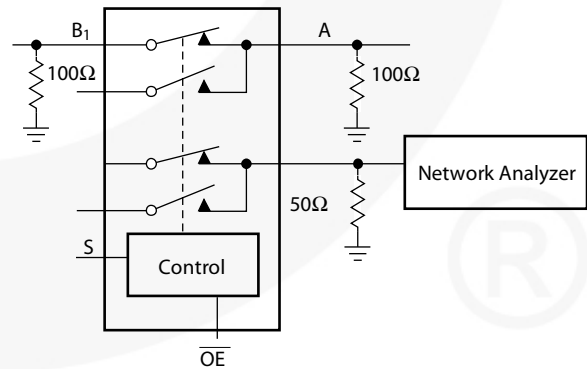

Figure 12. Crosstalk Test

AC Loadings and Waveforms

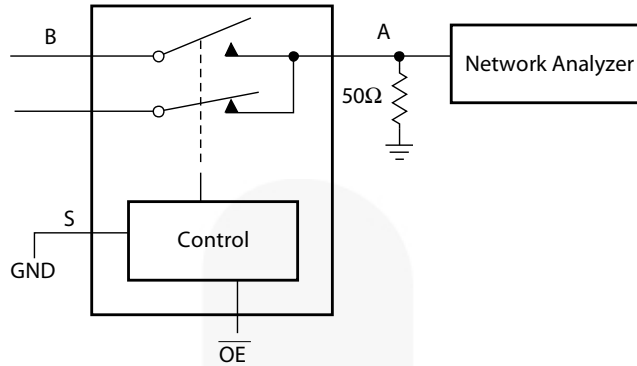

Figure 13. Bandwidth Test

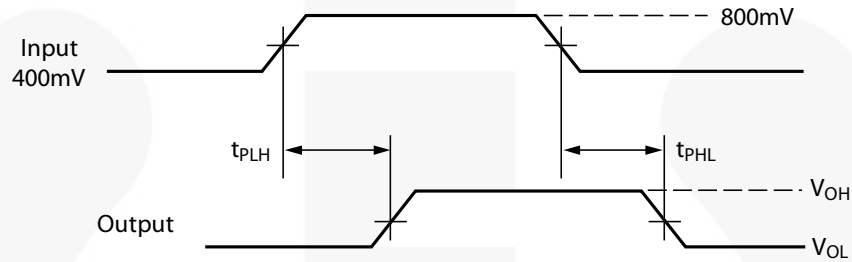

Figure 14. Propagation Delay

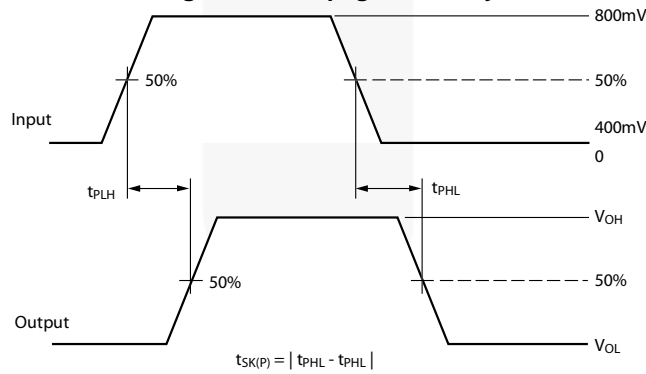

Figure 15. Pulse Skew $t_{SP(P)}$

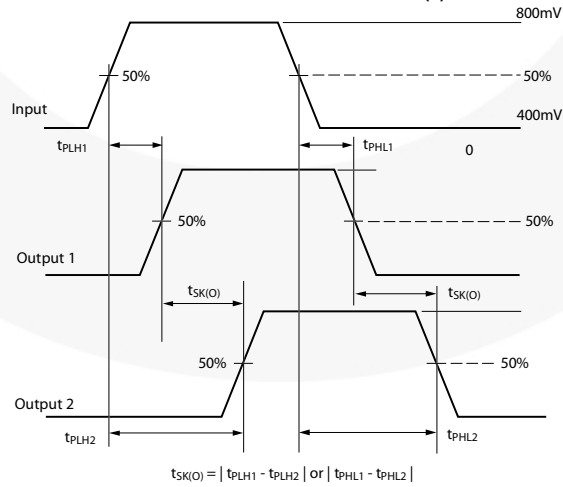

Figure 16. Output Skew $t_{SK(O)}$

Physical Dimensions

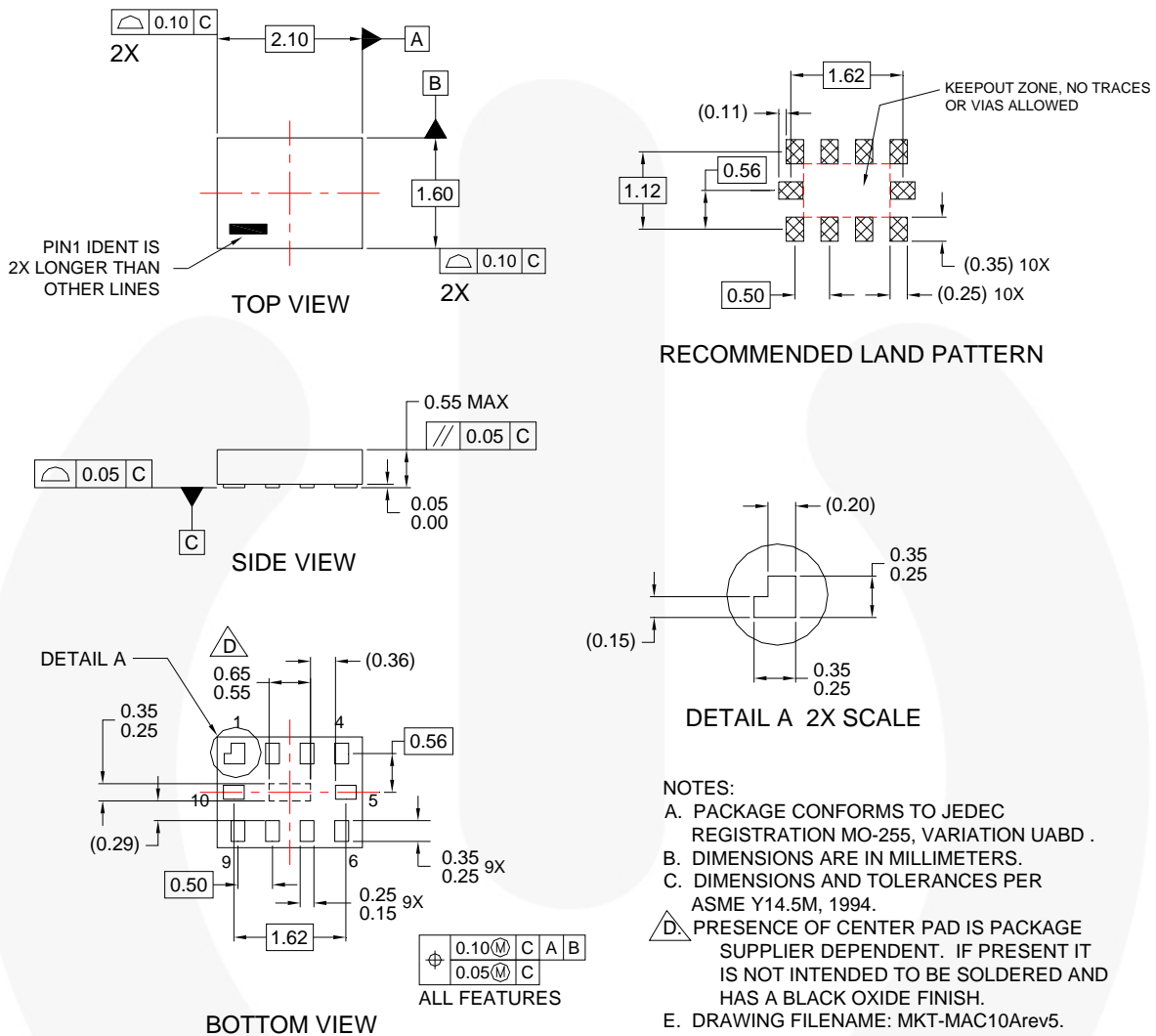

Figure 17. 10-Lead MicroPak™, 1.6 x 2.1mm

Package drawings are provided as a service to customers considering Fairchild components. Drawings may change in any manner without notice. Please note the revision and/or date on the drawing and contact a Fairchild Semiconductor representative to verify or obtain the most recent revision. Package specifications do not expand the terms of Fairchild's worldwide terms and conditions, specifically the warranty therein, which covers Fairchild products.

Always visit Fairchild Semiconductor's online packaging area for the most recent package drawings:
<http://www.fairchildsemi.com/packaging/>

For current tape and reel specifications, visit Fairchild Semiconductor's online packaging area:
http://www.fairchildsemi.com/products/logic/pdf/micropak_tr.pdf

Physical Dimensions

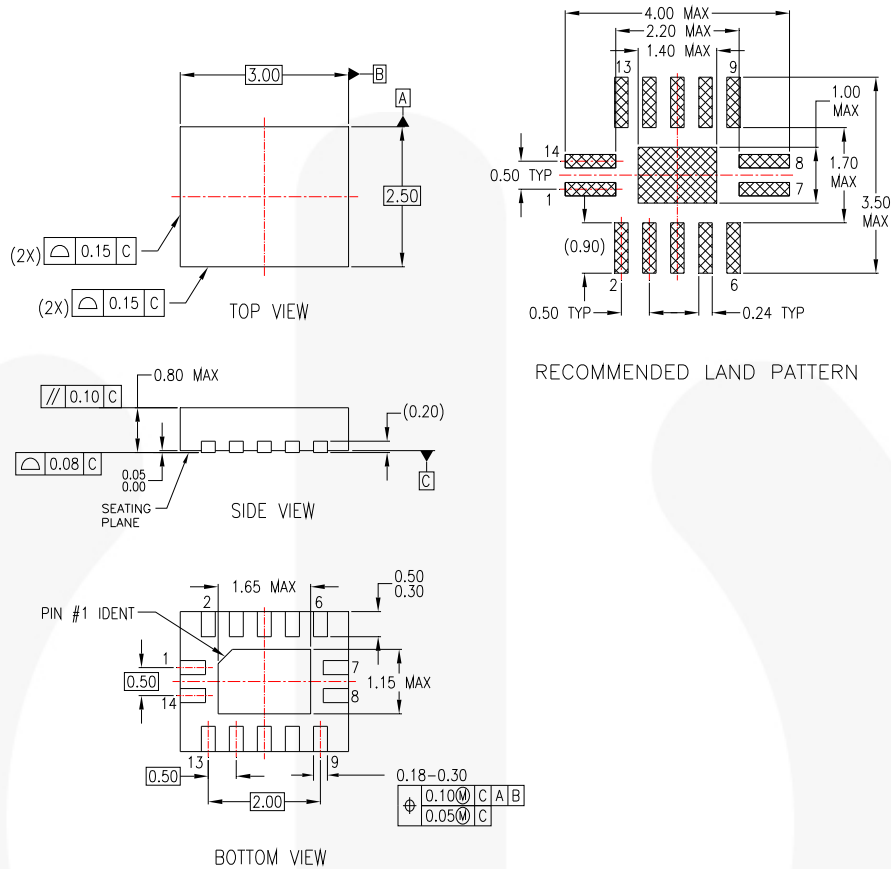

NOTES:

- A. CONFORMS TO JEDEC REGISTRATION MO-241, VARIATION AA
- B. DIMENSIONS ARE IN MILLIMETERS.
- C. DIMENSIONS AND TOLERANCES PER ASME Y14.5M, 1994

MLP14ArevA

Figure 18. 14-Terminal Depopulation Quad Very-Thin Flat Pack No Lead (DQFN), JEDEC MO-241, 2.5 X 3.0mm

Package drawings are provided as a service to customers considering Fairchild components. Drawings may change in any manner without notice. Please note the revision and/or date on the drawing and contact a Fairchild Semiconductor representative to verify or obtain the most recent revision. Package specifications do not expand the terms of Fairchild's worldwide terms and conditions, specifically the warranty therein, which covers Fairchild products.

Always visit Fairchild Semiconductor's online packaging area for the most recent package drawings:

<http://www.fairchildsemi.com/packaging/>

For current tape and reel specifications, visit Fairchild Semiconductor's online packaging area:

<http://www.fairchildsemi.com/ms/MS/MS-522.pdf>

Physical Dimensions

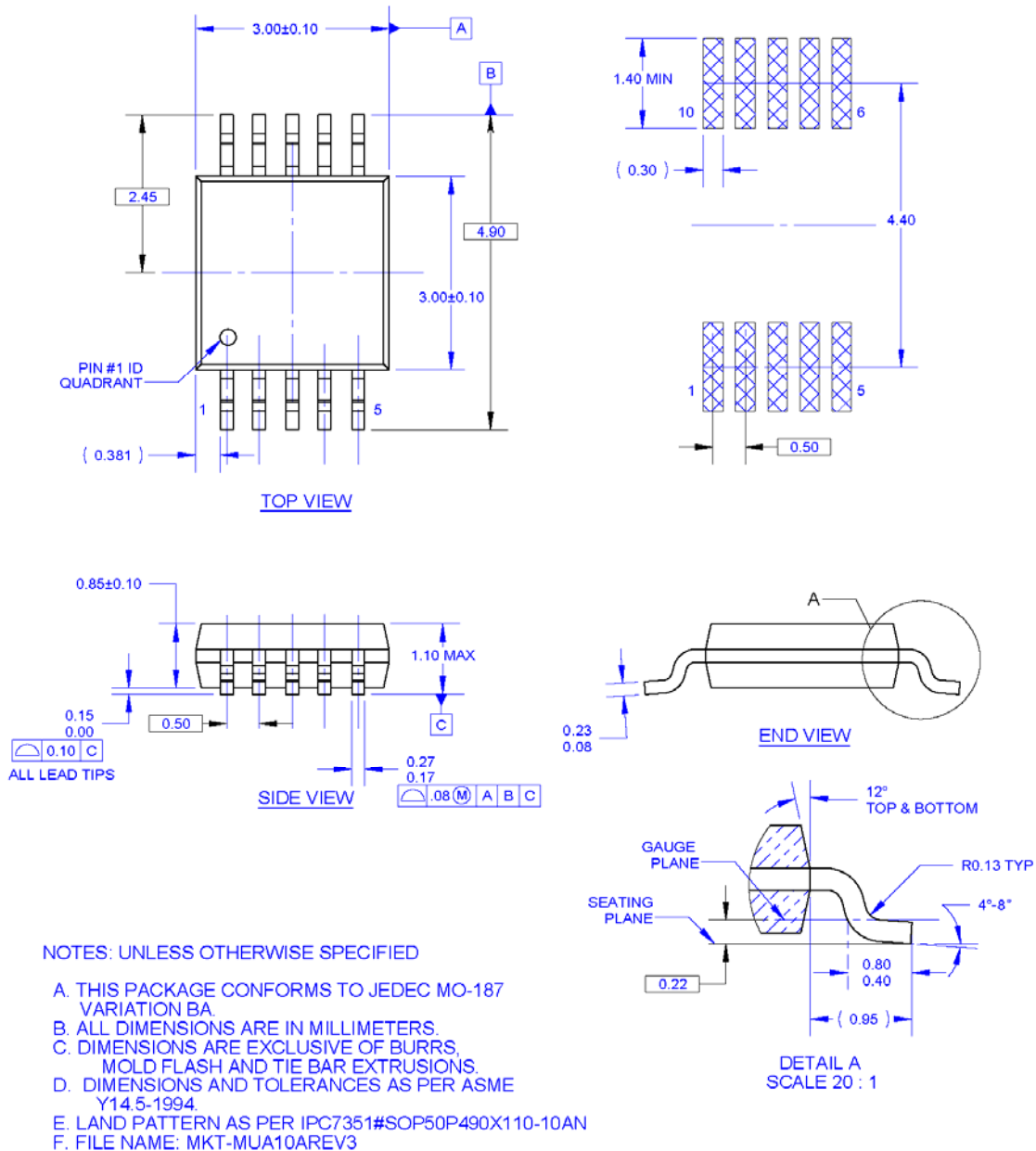

Figure 19. 10-Lead Molded Small Outline Package (MSOP), JEDEC MO-187, 3.0mm Wide

Package drawings are provided as a service to customers considering Fairchild components. Drawings may change in any manner without notice. Please note the revision and/or date on the drawing and contact a Fairchild Semiconductor representative to verify or obtain the most recent revision. Package specifications do not expand the terms of Fairchild's worldwide terms and conditions, specifically the warranty therein, which covers Fairchild products.

Always visit Fairchild Semiconductor's online packaging area for the most recent package drawings:
<http://www.fairchildsemi.com/packaging/>

For current tape and reel specifications, visit Fairchild Semiconductor's online packaging area:
http://www.fairchildsemi.com/products/analog/pdf/msop10_tr.pdf



TRADEMARKS

The following includes registered and unregistered trademarks and service marks, owned by Fairchild Semiconductor and/or its global subsidiaries, and is not intended to be an exhaustive list of all such trademarks.

2Cool™
AccuPower™
AX-CAP™*
BitSiC™
Build it Now™
CorePLUS™
CorePOWER™
CROSSVOLT™
CTL™
Current Transfer Logic™
DEUXPEED®
Dual Cool™
EcoSPARK®
EfficientMax™
ESBC™
F®
Fairchild®
Fairchild Semiconductor®
FACT Quiet Series™
FACT®
FAST®
FastvCore™
FETBench™
FlashWriter®*
FPS™

F-PFS™
FRFET®
Global Power Resource™
GreenBridge™
Green FPS™
Green FPS™ e-Series™
Gmax™
GTO™
IntelliMAX™
ISOPLANAR™
Making Small Speakers Sound Louder and Better™
MegaBuck™
MICROCOUPLER™
MicroFET™
MicroPak™
MicroPak2™
MillerDrive™
MotionMax™
Motion-SPM™
mWSaver™
OptoHiT™
OPTOLOGIC®
OPTOPLANAR®

PowerTrench®
PowerXS™
Programmable Active Droop™
QFET®
QS™
Quiet Series™
RapidConfigure™
™
Saving our world, 1mW/W/kW at a time™
SignalWise™
SmartMax™
SMART START™
Solutions for Your Success™
SPM®
STEALTH™
SuperFET®
SuperSOT™-3
SuperSOT™-6
SuperSOT™-8
SupreMOS®
SyncFET™
Sync-Lock™
 SYSTEM GENERAL®*

The Power Franchise®
the **power** franchise
TinyBoost™
TinyBuck™
TinyCalc™
TinyLogic®
TINYOPTO™
TinyPower™
TinyPWM™
TinyWire™
TranSiC™
TriFault Detect™
TRUECURRENT®*
µSerDes™
 SerDes™
UHC®
Ultra FRFET™
UniFET™
VCX™
VisualMax™
VoltagePlus™
XS™

* Trademarks of System General Corporation, used under license by Fairchild Semiconductor.

DISCLAIMER

FAIRCHILD SEMICONDUCTOR RESERVES THE RIGHT TO MAKE CHANGES WITHOUT FURTHER NOTICE TO ANY PRODUCTS HEREIN TO IMPROVE RELIABILITY, FUNCTION, OR DESIGN. FAIRCHILD DOES NOT ASSUME ANY LIABILITY ARISING OUT OF THE APPLICATION OR USE OF ANY PRODUCT OR CIRCUIT DESCRIBED HEREIN; NEITHER DOES IT CONVEY ANY LICENSE UNDER ITS PATENT RIGHTS, NOR THE RIGHTS OF OTHERS. THESE SPECIFICATIONS DO NOT EXPAND THE TERMS OF FAIRCHILD'S WORLDWIDE TERMS AND CONDITIONS, SPECIFICALLY THE WARRANTY THEREIN, WHICH COVERS THESE PRODUCTS.

LIFE SUPPORT POLICY

FAIRCHILD'S PRODUCTS ARE NOT AUTHORIZED FOR USE AS CRITICAL COMPONENTS IN LIFE SUPPORT DEVICES OR SYSTEMS WITHOUT THE EXPRESS WRITTEN APPROVAL OF FAIRCHILD SEMICONDUCTOR CORPORATION.

As used herein:

1. Life support devices or systems are devices or systems which, (a) are intended for surgical implant into the body or (b) support or sustain life, and (c) whose failure to perform when properly used in accordance with instructions for use provided in the labeling, can be reasonably expected to result in a significant injury of the user.
2. A critical component in any component of a life support, device, or system whose failure to perform can be reasonably expected to cause the failure of the life support device or system, or to affect its safety or effectiveness.

ANTI-COUNTERFEITING POLICY

Fairchild Semiconductor Corporation's Anti-Counterfeiting Policy. Fairchild's Anti-Counterfeiting Policy is also stated on our external website, www.fairchildsemi.com, under Sales Support.

Counterfeiting of semiconductor parts is a growing problem in the industry. All manufacturers of semiconductor products are experiencing counterfeiting of their parts. Customers who inadvertently purchase counterfeit parts experience many problems such as loss of brand reputation, substandard performance, failed applications, and increased cost of production and manufacturing delays. Fairchild is taking strong measures to protect ourselves and our customers from the proliferation of counterfeit parts. Fairchild strongly encourages customers to purchase Fairchild parts either directly from Fairchild or from Authorized Fairchild Distributors who are listed by country on our web page cited above. Products customers buy either from Fairchild directly or from Authorized Fairchild Distributors are genuine parts, have full traceability, meet Fairchild's quality standards for handling and storage and provide access to Fairchild's full range of up-to-date technical and product information. Fairchild and our Authorized Distributors will stand behind all warranties and will appropriately address any warranty issues that may arise. Fairchild will not provide any warranty coverage or other assistance for parts bought from Unauthorized Sources. Fairchild is committed to combat this global problem and encourage our customers to do their part in stopping this practice by buying direct or from authorized distributors.

PRODUCT STATUS DEFINITIONS

Definition of Terms

Datasheet Identification	Product Status	Definition
Advance Information	Formative / In Design	Datasheet contains the design specifications for product development. Specifications may change in any manner without notice.
Preliminary	First Production	Datasheet contains preliminary data; supplementary data will be published at a later date. Fairchild Semiconductor reserves the right to make changes at any time without notice to improve design.
No Identification Needed	Full Production	Datasheet contains final specifications. Fairchild Semiconductor reserves the right to make changes at any time without notice to improve the design.
Obsolete	Not In Production	Datasheet contains specifications on a product that is discontinued by Fairchild Semiconductor. The datasheet is for reference information only.

Rev. I61