



Test Procedure for the LV8417CSGEVB Evaluation Board

DC motor control

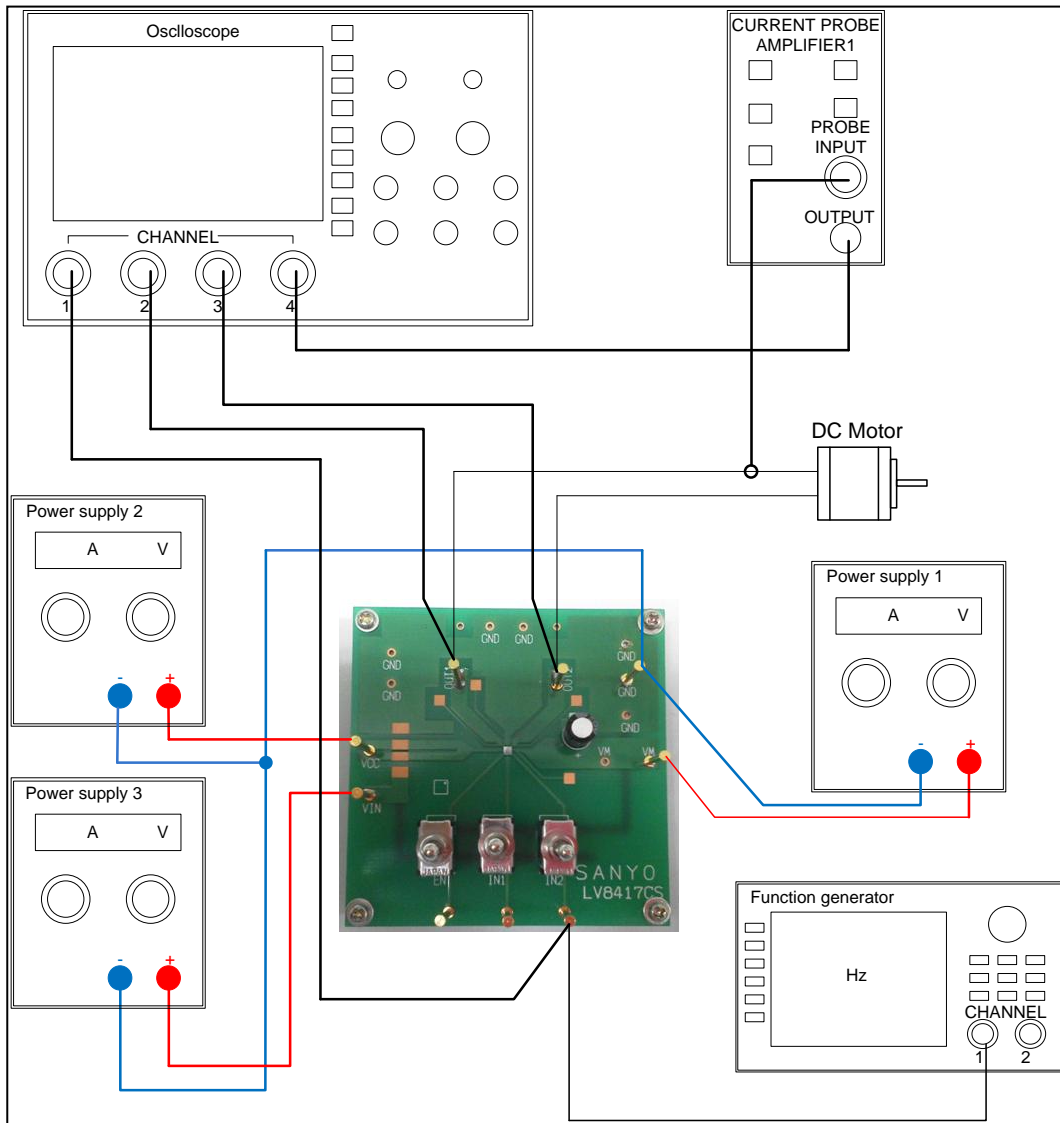



Table1: Required Equipment

Equipment	Efficiency
Power supply1	25V-3A
Power supply2	25V-3A
Power supply3	5V-0.5A
Function generator	200kHz
Oscilloscope	4 channel
Current probe	-
LV8417CS Evaluation Board	-
DC Motor	25V-2A



Test Procedure:

1. Connect the test setup as shown above.
2. Set it according to the following guide.

[Supply Voltage]

VM (2.0 to 10.5V) : Power Supply for LSI
 VCC (2.7 to 5.5V) :Control Supply for LSI
 VIN (0 to VCC) : Logic “High” voltage for toggle switch

[Toggle Switch State]

Upper Side: High (VIN)
 Middle: Open, enable to external logic input
 Lower Side: Low (GND)

[Operation Guide]

1. Initial Condition Setting: Set “Open” the toggle switches ENA, IN1 and IN2.
 2. Power Supply: Supply DC voltage to VM, VCC and VIN.
 3. Ready for Operation from Standby State: Turn “High” the ENA terminal toggle switch.
 4. Motor Operation: Input the signal which is in condition to want to operate into IN1 and IN2.
3. Check the IN2, OUT1, and OUT2 terminal voltage at scope CH1, CH2, and CH3, and the output current waveform at scope CH4.

Table2: Desired Results

INPUT	OUTPUT
VM=6V VCC=3V VIN=3V ENA=High IN1=High IN2=10KHz (Duty50%)	* Refer to the following waveform

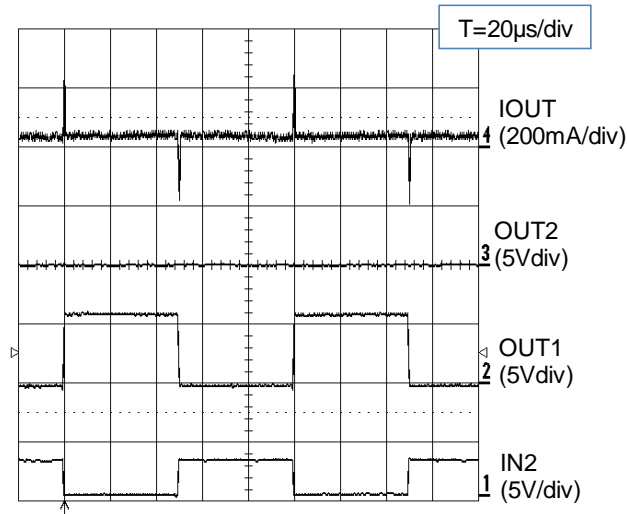

DCM output control logic

ENA	IN1	IN2	OUT1	OUT2	MODE
H	H	H	L	L	Brake
	H	L	H	L	Forward
	L	H	L	H	Reverse
	L	L	Z	Z	Standby
L	-	-	Z	Z	Standby