

Test Procedure for the LV8549MGEVB Evaluation Board



SANYO Semiconductors

An ON Semiconductor Company

For Stepping Motor Control

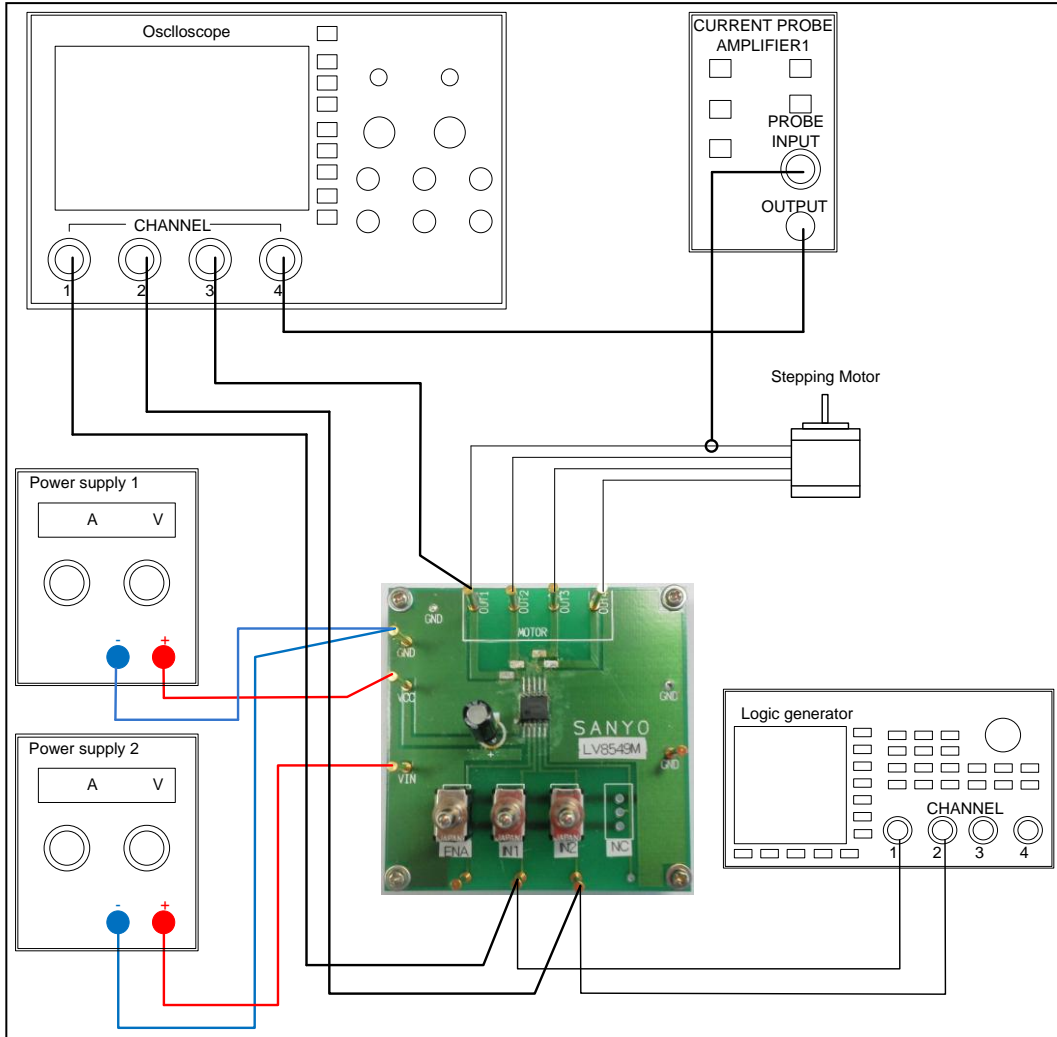

Table1: Required Equipment

Equipment	Efficiency
Power supply1	25V-3A
Power supply2	5V-0.5A
Logic generator	200kHz
Oscilloscope	4 channel
Current probe1	-
LV8549M Evaluation Board	-
Stepping Motor	25V-2A

Test Procedure:

1. Connect the test setup as shown above.
2. Set it according to the following specifications:

Supply Voltage

- VCC (4 to 16V) : Power Supply for LSI
- VIN (1.8 to 5.5V) : Logic “High” voltage for toggle switch

Toggle Switch State

- Upper Side: High (VIN)
- Middle: Open, enable to external logic input
- Lower Side: Low (GND)

Operation Guide

- Initial Condition Setting: Set “Open” the toggle switches ENA , IN1 and IN2.
 - Power Supply: Supply DC voltage to VCC and VIN.
 - Ready for Operation from Standby State: Turn “High” the ENA terminal toggle switch.
 - Motor Operation: Input the signal which is in condition to want to operate into IN1 and IN2.
3. Check the IN1 , IN2 and OUT1 terminal voltage at scope CH1 , CH2 and CH3, and the output current waveform at scope CH4.

Table2: Desired Results

INPUT	OUTPUT
VCC=12V VIN=5V ENA=H IN1 , IN2=Full-step signal	* Refer to the following waveform

LV8549M Full-Step VCC=12V 200pps

