

LV8773

Bi-CMOS LSI

PWM Constant-Current Control Stepping Motor Driver

Overview

The LV8773 is a 2-channel H-bridge driver IC, which supports forward, reverse, brake, and standby of a motor. It is ideally suited for driving brushed DC motors and stepping motors used in office equipment and amusement applications.

Features

- BiCDMOS process IC
- Low on resistance (upper side: 0.3Ω ; lower side: 0.25Ω ; total of upper and lower: 0.55Ω ; $T_a = 25^\circ\text{C}$, $I_O = 2\text{A}$)
- Motor current selectable in two steps
- Output short-circuit protection circuit (selectable from latch-type or auto-reset-type) incorporated
- Unusual condition warning output pins
- No control power supply required

Typical Applications

- Industrial
- Cash Machine
- Pachinko Game Machine
- Slot Machine
- Embroidery Machine

LV8773

Package Dimensions

unit: mm (typ)

3241A

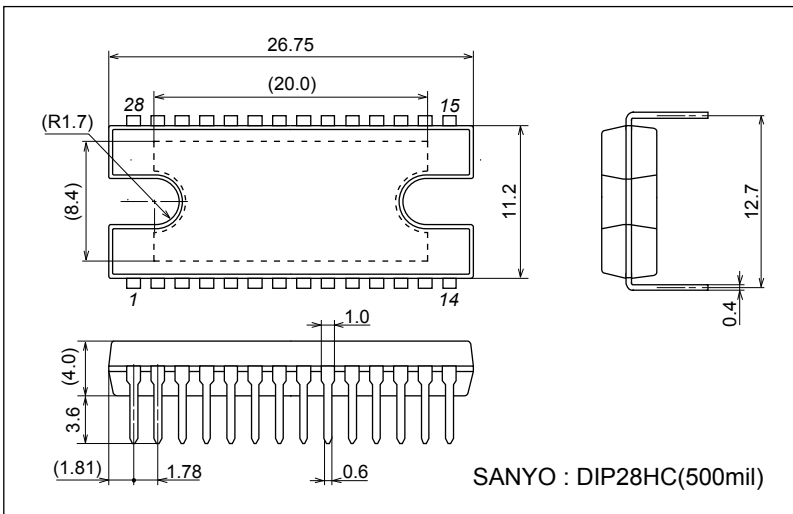

Pin Assignment

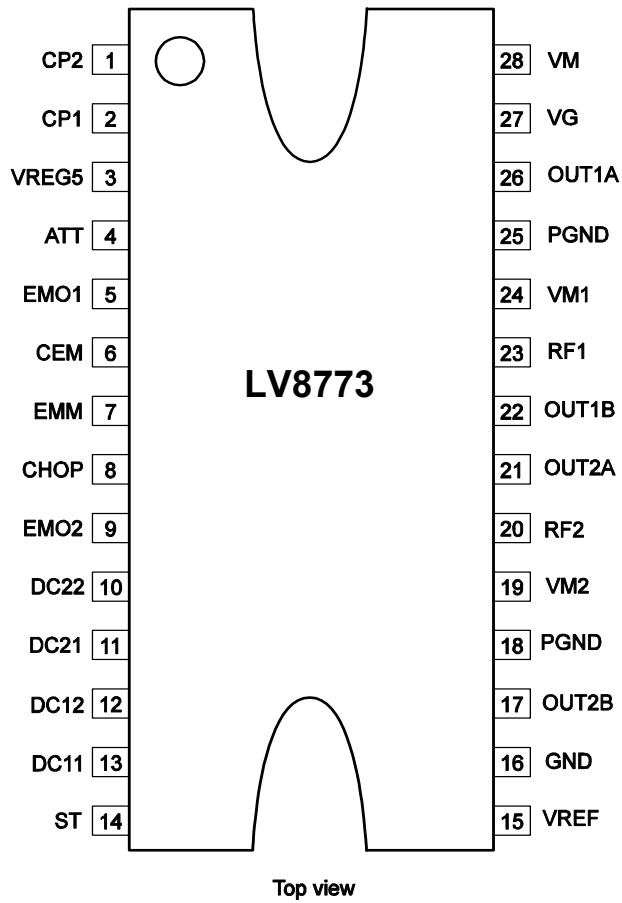

Block Diagram

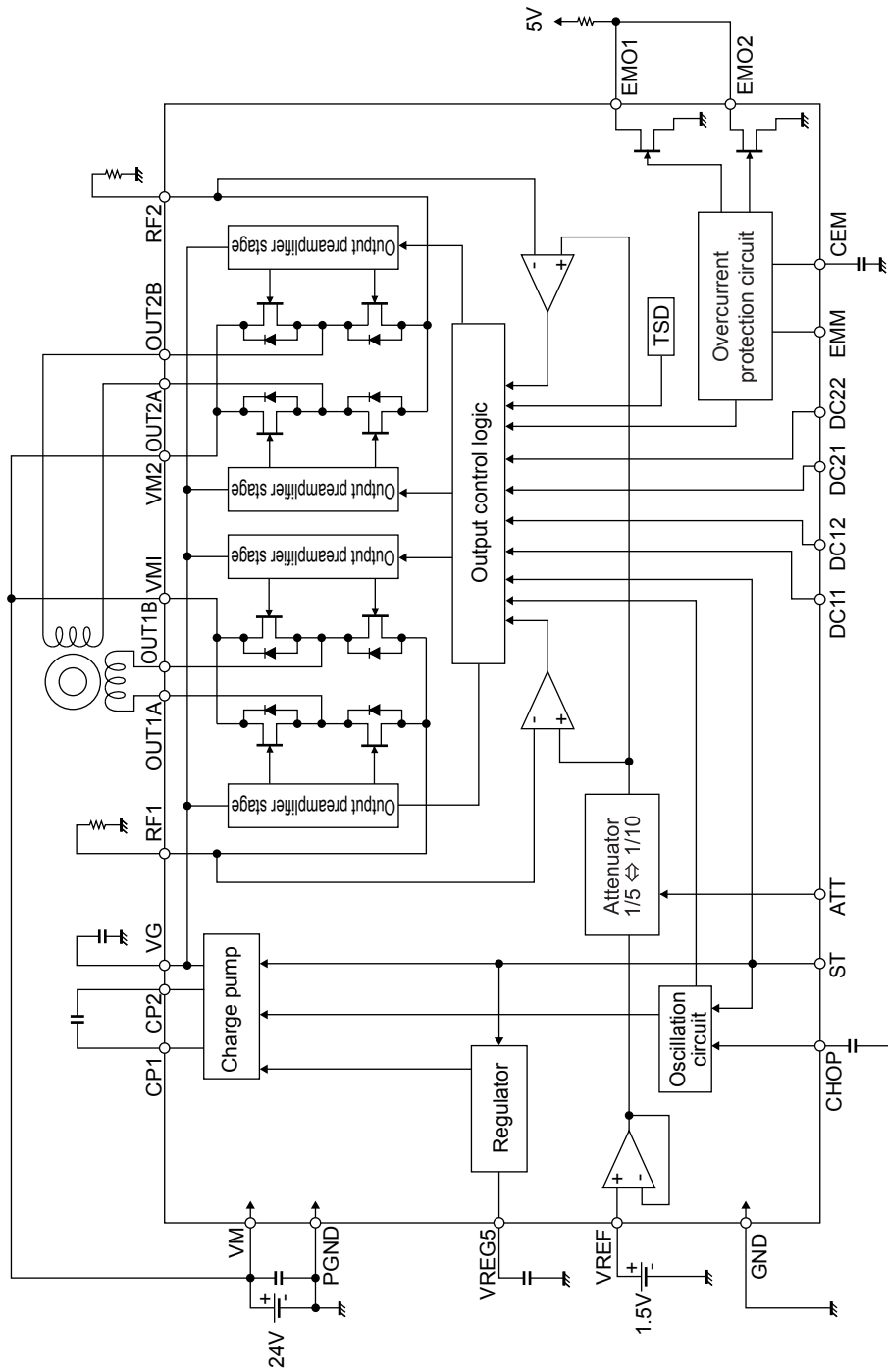

Specifications

Absolute Maximum Ratings at Ta = 25°C

Parameter	Symbol	Conditions	Ratings	Unit
Supply voltage	VM max		36	V
Output peak current	IO peak	Tw ≤ 10ms, duty 20%	2.5	A
Output current	IO max		2	A
Logic input voltage	VIN		-0.3 to +6	V
EMO1/EMO2 input voltage	Vemo/Vemo2		-0.3 to +6	V
Allowable power dissipation	Pd max1	1 unit	3.0	W
	Pd max2	*	6.2	W
Operating temperature	Topr		-20 to +85	°C
Storage temperature	Tstg		-55 to +150	°C

* Specified circuit board: 90.0mm×90.0mm×1.6mm, glass epoxy 2-layer board.

Allowable Operating Ratings at Ta = 25°C

Parameter	Symbol	Conditions	Ratings	Unit
Supply voltage range	VM		9 to 32	V
Logic input voltage	VIN		0 to 5.5	V
VREF input voltage range	VREF		0 to 3	V

Electrical Characteristics at Ta = 25°C, VM = 24V, VREF = 1.5V

Parameter	Symbol	Conditions	Ratings			Unit
			min	typ	max	
Standby mode current drain	IMst	ST = "L"		100	400	μA
Current drain	IM	ST = "H", OE = "L", with no load		3.2	5	mA
VREG5 output voltage	Vreg5	IO = -1mA	4.5	5	5.5	V
Thermal shutdown temperature	TSD	Design guarantee	150	180	200	°C
Thermal hysteresis width	ΔTSD	Design guarantee		40		°C
Motor driver						
Output on resistance	Ronu	IO = 2A, Upper-side on resistance		0.3	0.4	Ω
	Rond	IO = 2A, Lower-side on resistance		0.25	0.33	Ω
Output leakage current	IOleak				50	μA
Diode forward voltage	VD	ID = -2A		1.2	1.4	V
Logic pin input current	IINL	VIN = 0.8V	4	8	12	μA
	IINH	VIN = 5V	30	50	70	μA
Logic high-level input voltage	VINH		2.0			V
Logic low-level input voltage	VINL				0.8	V
Current setting comparator threshold voltage (current attenuation rate switching)	Vtatt0	ATT = L	0.291	0.3	0.309	V
	Vtatt1	ATT = H	0.143	0.15	0.157	V
Chopping frequency	Fchop	Cchop = 220pF	36.3	45.4	54.5	kHz
CHOP pin charge/discharge current	Ichop		7	10	13	μA
Chopping oscillation circuit threshold voltage	Vtup		0.8	1	1.2	V
	Vtdown		0.4	0.5	0.6	V
VREF pin input current	Iref	VREF = 1.5V	-0.5			μA
Charge pump						
VG output voltage	VG		28	28.7	29.8	V
Rise time	tONG	VG = 0.1μF		200		μS
Oscillator frequency	Fosc		90	125	150	kHz
Output short-circuit protection						
EMO1/EMO2 pin saturation voltage	Vsatemo	Iemo = 1mA			400	mV
CEM pin charge current	Icem	Vcem = 0V	7	10	13	μA
CEM pin threshold voltage	Vtcm		0.8	1	1.2	V

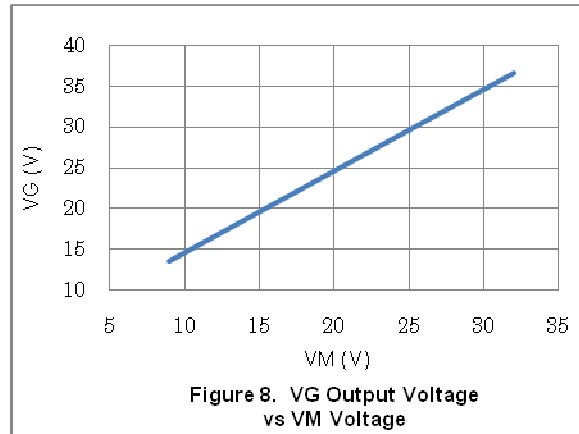
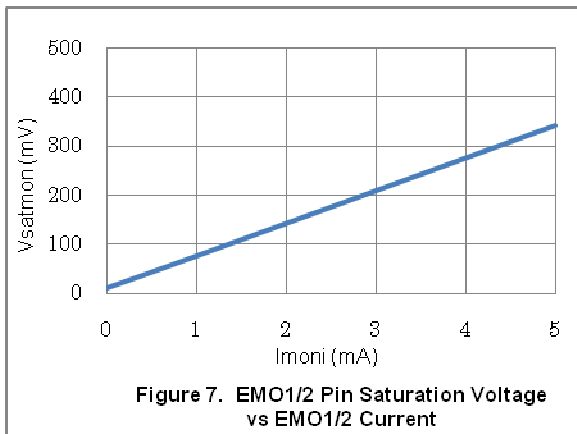
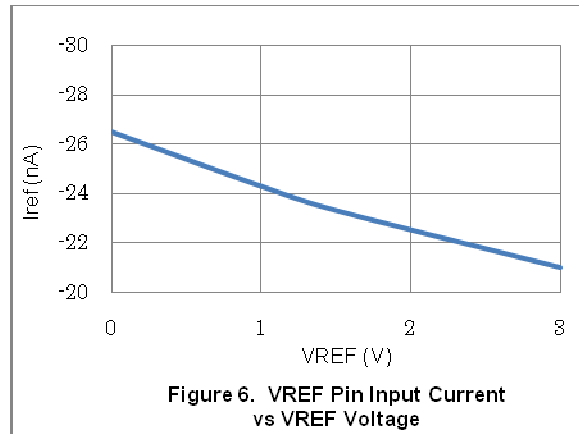
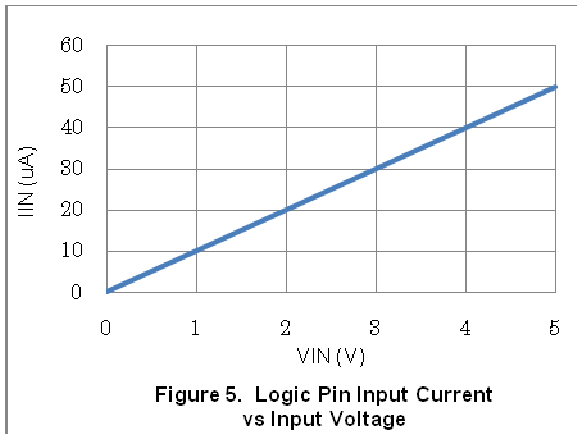
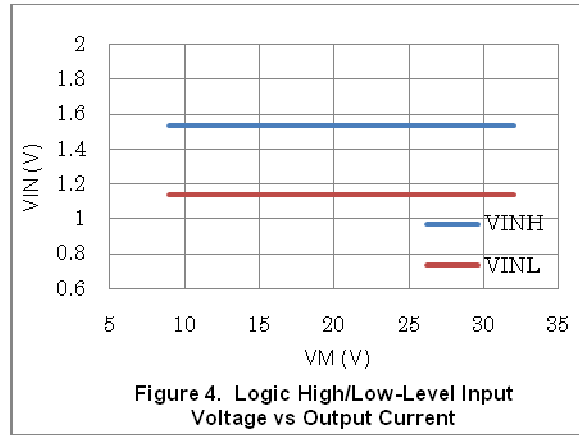
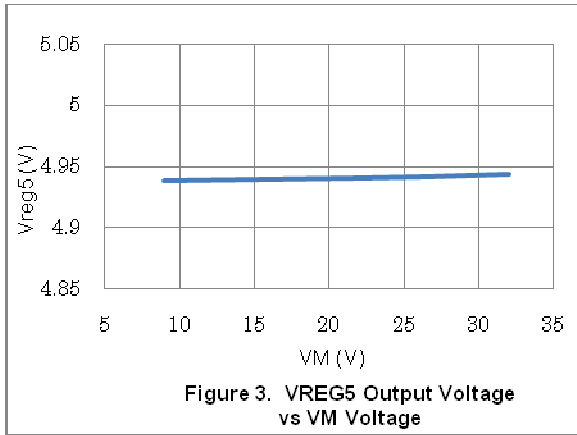
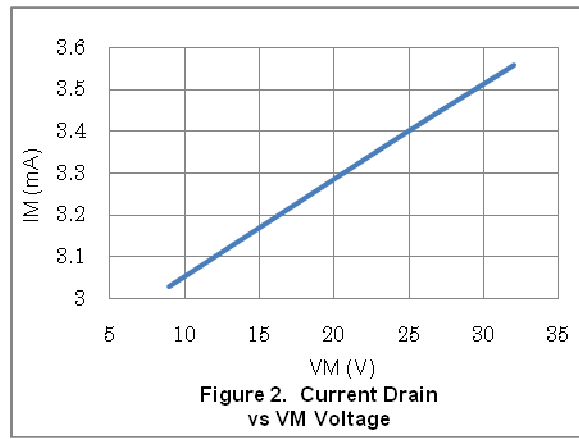
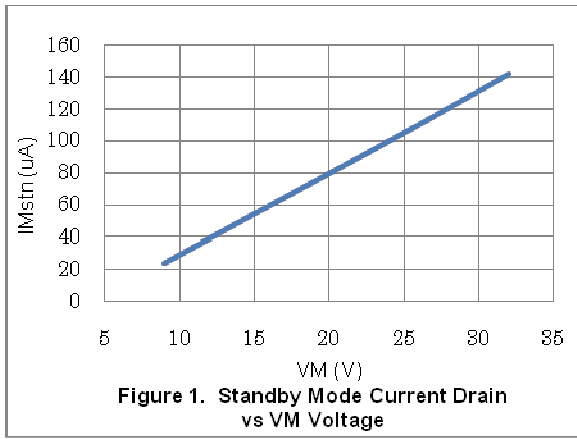

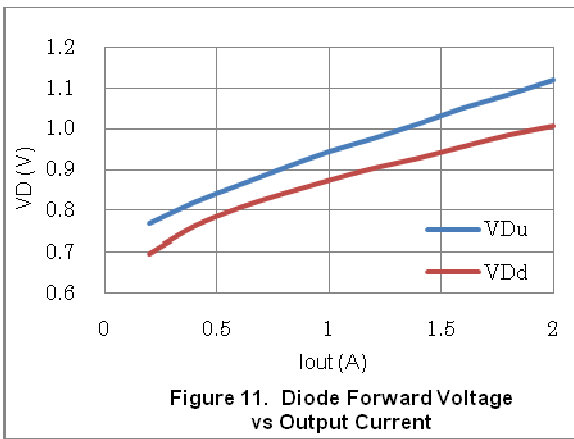
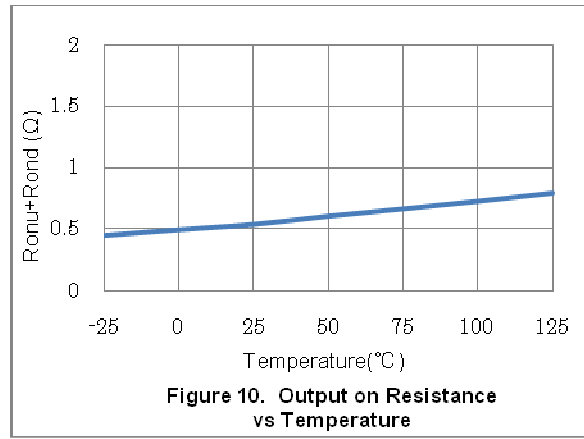
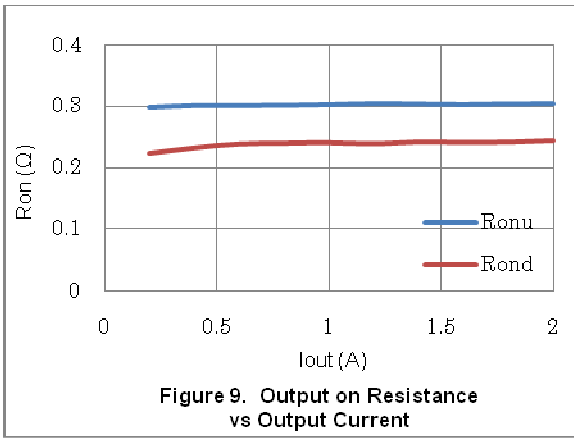

LV8773

Pin Functions

Pin No.	Pin Name	Pin Function	Equivalent Circuit
4 7 10 11 12 13	ATT2 EMM DC22 DC21 DC12 DC11	Motor holding current switching pin. Output short-circuit protection mode switching pin. Channel 2 output control input pin 2 Channel 2 output control input pin 1 Channel 1 output control input pin 2 Channel 1 output control input pin 1	
14	ST	Chip enable pin.	
17 18, 25 19 20 21 22 23 24 26	OUT2B PGND VM2 RF2 OUT2A OUT1B RF1 VM1 OUT1A	Channel 2 OUTB output pin. Power system ground. Channel 2 motor power supply connection pin. Channel 2 current-sense resistor connection pin. Channel 2 OUTA output pin. Channel 1 OUTB output pin. Channel 1 current-sense resistor connection pin. Channel 1 motor power supply pin. Channel 1 OUTA output pin.	
27 28 1 2	VG VM CP2 CP1	Charge pump capacitor connection pin. Motor power supply connection pin. Charge pump capacitor connection pin. Charge pump capacitor connection pin.	
16	GND	Ground.	

Continued on next page.

LV8773

Continued from preceding page.

Pin No.	Pin Name	Pin Function	Equivalent Circuit
15	VREF	Constant current control reference voltage input pin.	
3	VREG5	Internal power supply capacitor connection pin.	
5 9	EMO1 EMO2	Channel 1 output short-circuit state warning output pin. Channel 2 output short-circuit state warning output pin.	
6	CEM	Pin to connect the output short-circuit state detection time setting capacitor	
8	CHOP	Copping frequency setting capacitor connection pin.	

Description of operation

(1) Chip enables function

This IC is switched between standby and operating mode by setting the ST pin. In standby mode, the IC is set to power-save mode and all logic is reset. In addition, the internal regulator circuit and charge pump circuit do not operate in standby mode.

ST	Mode	Internal regulator	Charge pump
Low or Open	Standby mode	Standby	Standby
High	Operating mode	Operating	Operating

(2) Output control logic

input		output		mode
DC11(21)	DC12(22)	OUT1(2)A	OUT1(2)B	
L	L	OFF	OFF	Stand-by
H	L	H	L	CW (Forward)
L	H	L	H	CCW (reverse)
H	H	L	L	brake

The following show an output waveform at the time of the above logic setting.

Forward↔Brake

No load , VM=24V , DC12=10kHz(DC11=H)

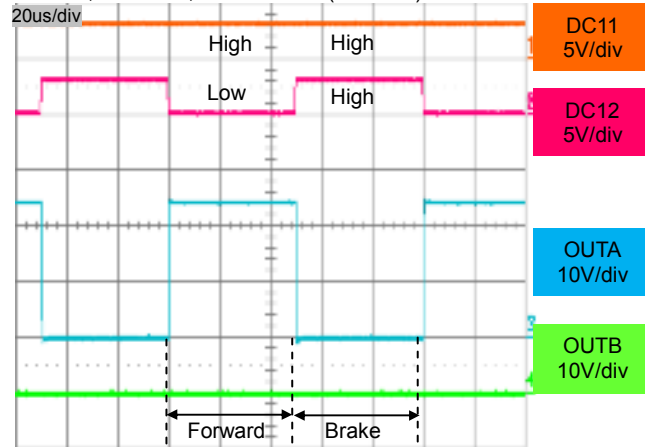
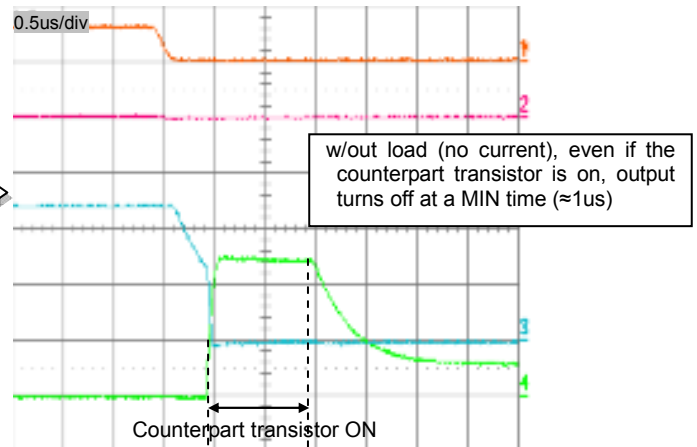
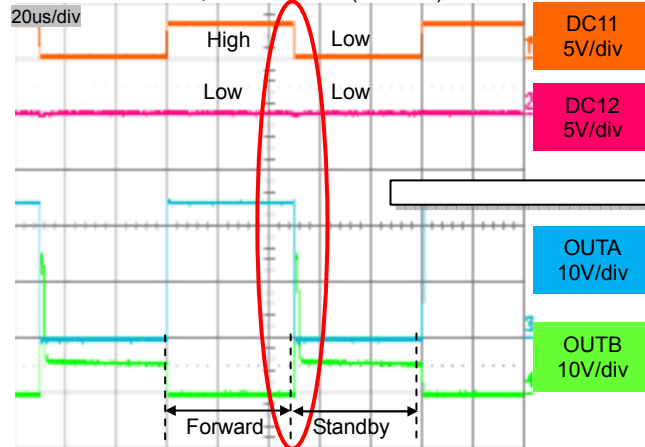

Figure 12. Forward↔Brake control waveform

Forward↔Standby

No load VM=24V, DC11=10 kHz (DC12=L)



Standby mode turns on the counterpart transistor (synchronous rectification). After motor current fades off, output turns off. Synchronous rectification reduces heat generation compared to diode regeneration.

Figure 13. Forward↔Standby control waveform

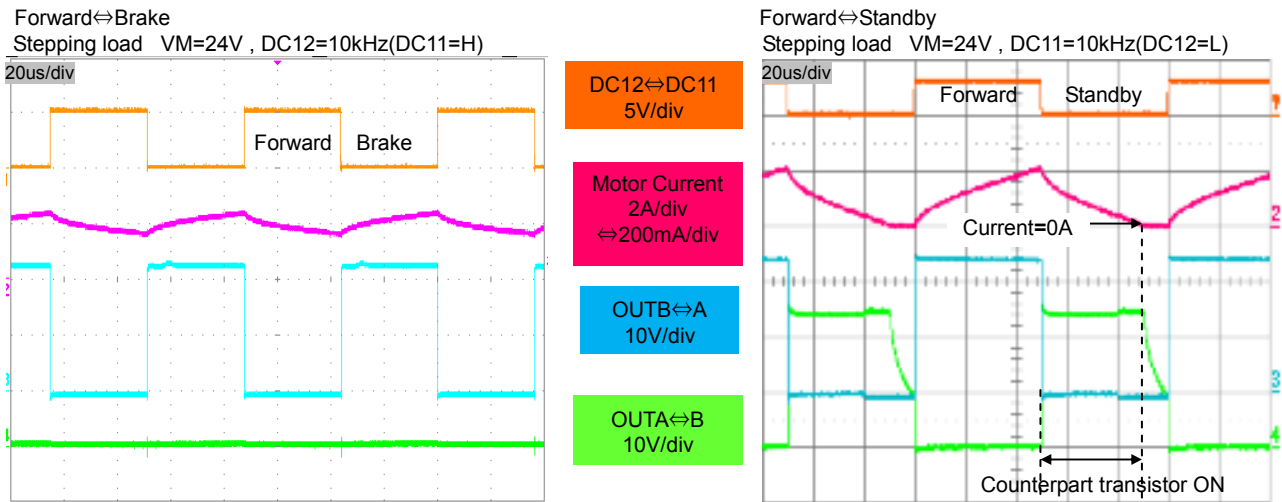

Figure 14. Stepping load control waveform

(3) Blanking period

If, when exercising PWM constant-current chopping control over the motor current, the mode is switched from decay to charge, the recovery current of the parasitic diode may flow to the current sensing resistance, causing noise to be carried on the current sensing resistance pin, and this may result in erroneous detection. To prevent this erroneous detection, a blanking period is provided to prevent the noise occurring during mode switching from being received. During this period, the mode is not switched from charge to decay even if noise is carried on the current sensing resistance pin.

This IC is the blanking time is fixed at approximately 2μs.

(4) Chopping frequency setting

For constant-current control, this IC performs chopping operations at the frequency determined by the capacitor (Cchop) connected between the CHOP pin and GND.

The chopping frequency is set as shown below by the capacitor (Cchop) connected between the CHOP pin and GND.

$$F_{chop} = I_{chop} / (C_{chop} \times V_{tchop} \times 2) \text{ (Hz)}$$

I_{chop}: Capacitor charge/discharge current, typ 10μA

V_{tchop}: Charge/discharge hysteresis voltage (V_{tup}-V_tdown), typ 0.5V

For instance, when C_{chop} is 220pF, the chopping frequency will be as follows:

$$F_{chop} = 10\mu A / (220pF \times 0.5V \times 2) = 45.4 \text{ kHz}$$

The higher the chopping frequency is, the greater the output switching loss becomes. As a result, heat generation issue arises. The lower the chopping frequency is, the lesser the heat generation becomes. However, current ripple occurs. Since noise increases when switching of chopping takes place, you need to adjust frequency with the influence to the other devices into consideration. The frequency range should be between 40 kHz and 125 kHz.

(5) Setting constant-current control

When the current of the motor reaches up to a set current by setting the output current, this IC does the short brake control by the automatic operation so that the current should not increase more than it.

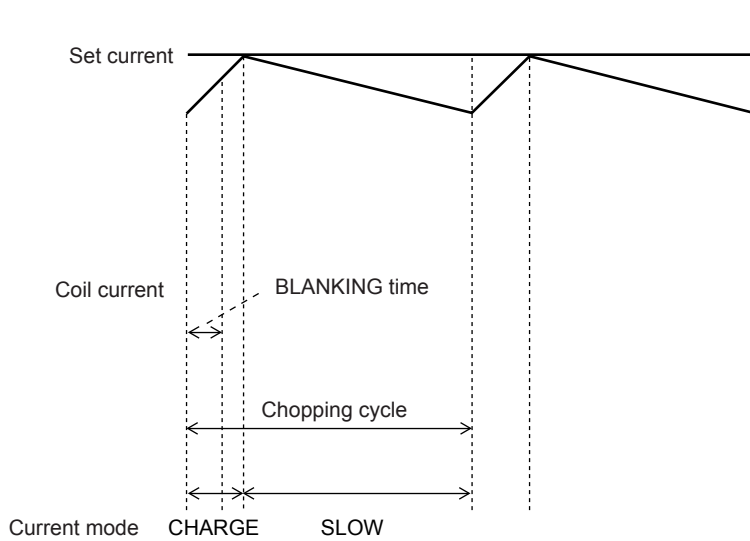

Based on the voltage input to the VREF pin and the resistance connected between RF and GND, the output current that is subject to the constant-current control is set using the calculation formula below:

$$I_{OUT} = (VREF/5)/RF \text{ resistance}$$

* The above setting is the output current at 100% of each excitation mode.

Make sure to avoid using LV8773 with setting VREF open or out of the recommendation operating range. Such usage causes increased output current; therefore, you cannot set optimum constant current. If you do not perform current control (i.e. using LV8773 without setting saturation drive or current limit), set the voltages as follows: VREF=5V or VREF=VREG5

Since power dissipation of RF resistor is $Pd = I_{out}^2 \times RF$, make sure to take allowable power dissipation into consideration.

The voltage input to the VREF pin can be switched to two-step settings depending on the statuses of the ATT.

Attenuation function for VREF input voltage

ATT	Current setting reference voltage attenuation ratio
Low	100%
High	50%

The formula used to calculate the output current when using the function for attenuating the VREF input voltage is given below.

$$I_{OUT} = (VREF/5) \times (\text{attenuation ratio})/RF \text{ resistance}$$

Example: At VREF of 1.5V, a reference voltage setting of 100% (ATT = L) and an RF resistance of 0.3Ω, the output current is set as shown below.

$$I_{OUT} = 1.5V/5 \times 100\%/0.3\Omega = 1.0A$$

If, in this state, ATT = H will be as follows:

$$I_{OUT} = 1.0A \times 50\% = 500mA$$

In this way, the output current is attenuated when the motor holding current is supplied so that power can be conserved.

(6) Output transistor operation mode

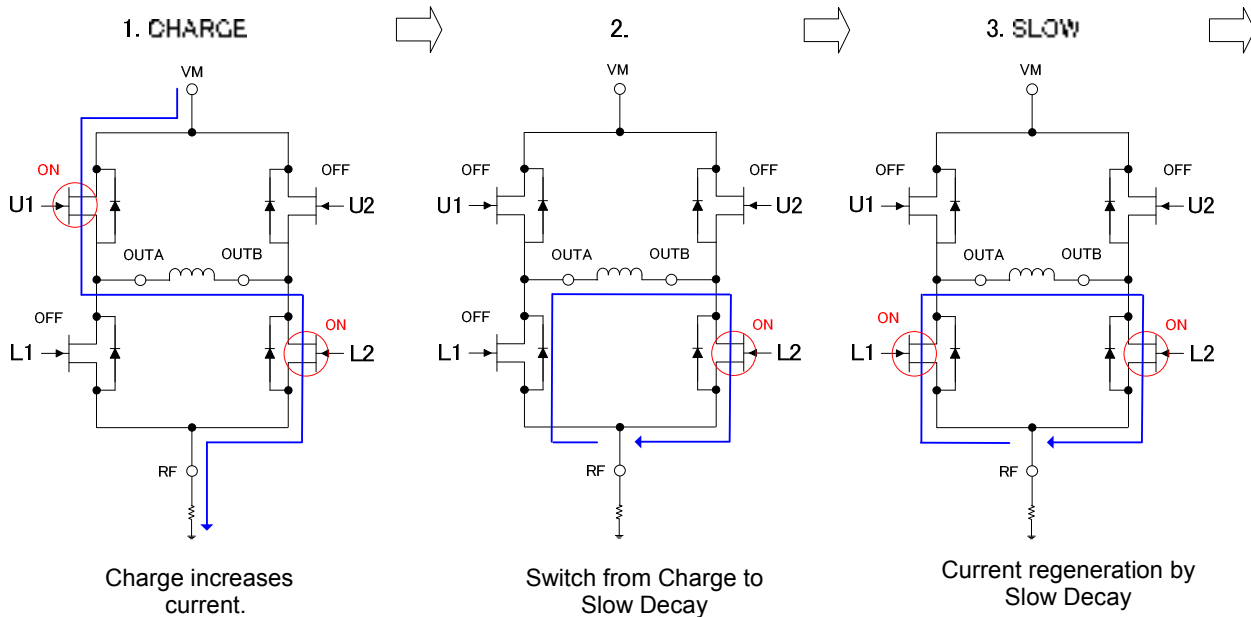

Figure 15. Switching operation

This IC controls constant current by performing chopping to output transistor.

As shown above, by repeating the process from 1 to 3, setting current is maintained.

Chopping consists of 2 modes: Charge/ Slow decay. In this IC, for switching mode (No.2), there are “off period” in upper and lower transistor to prevent crossover current between the transistors. This off period is set to be constant ($\approx 0.375\mu\text{s}$) which is controlled by the internal logic. The diagrams show parasitic diode generated due to structure of MOS transistor. When the transistor is off, output current is regenerated through this parasitic diode.

Output Transistor Operation Function

OUTA→OUTB (CHARGE)

Output Tr	CHARGE	SLOW
U1	ON	OFF
U2	OFF	OFF
L1	OFF	ON
L2	ON	ON

OUTB→OUTA (CHARGE)

Output Tr	CHARGE	SLOW
U1	OFF	OFF
U2	ON	OFF
L1	ON	ON
L2	OFF	ON

(7) Typical current waveform in each excitation mode when stepping motor parallel input control
Full step (CW mode)

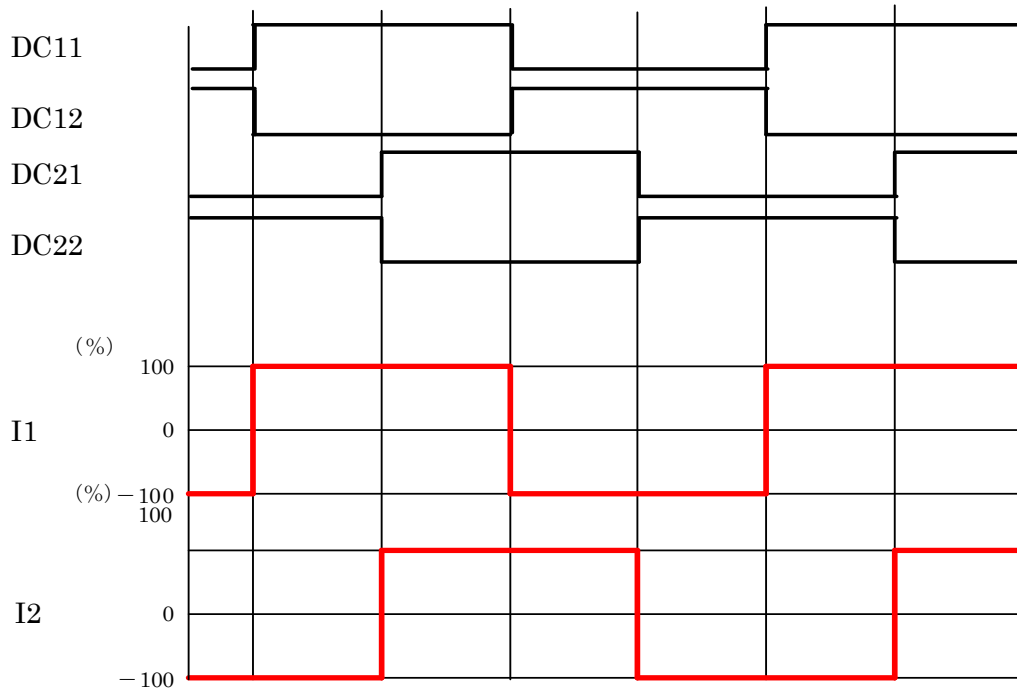

Half step (CW mode)

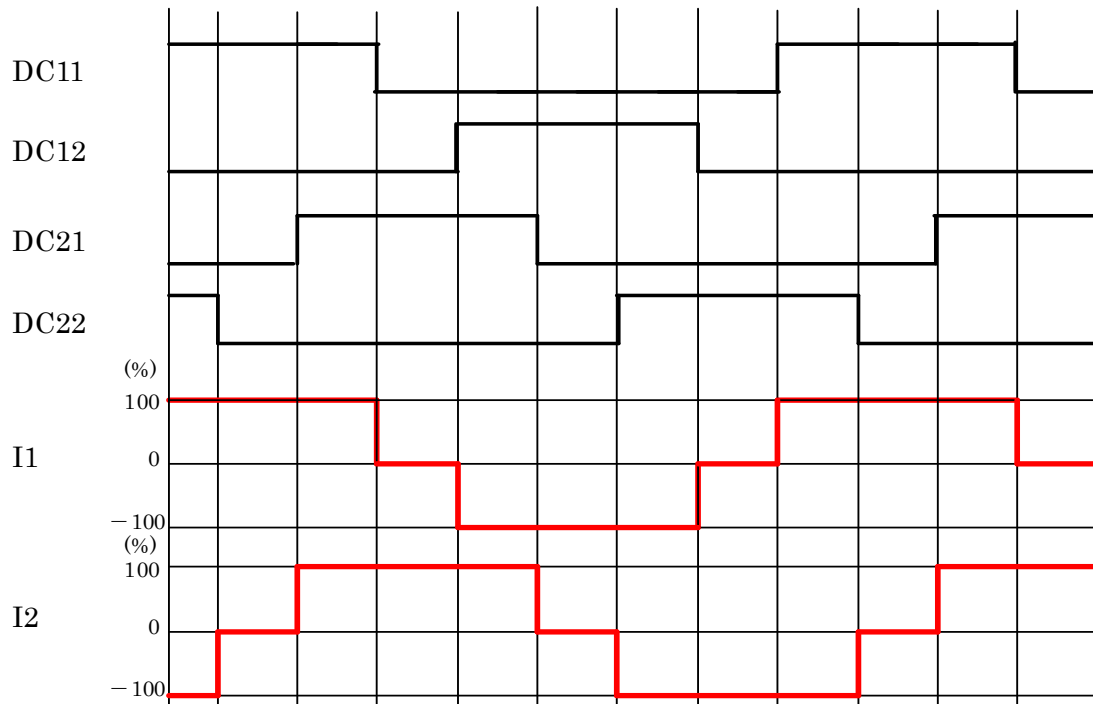

(8)PWM control

You can perform H-Bridge direct PWM control to DC11, DC12, DC21, and DC22 by inputting PWM signal. The maximum frequency of PWM signal is 200 kHz. However, dead zone is generated when On-Duty is around 0%. Make sure to select optimum PWM frequency according to the target control range.

Input-Output Characteristics of H-Bridge(Reference data)
 VM=24V, VREF=1.5V
 Forward/Reverse↔Brake

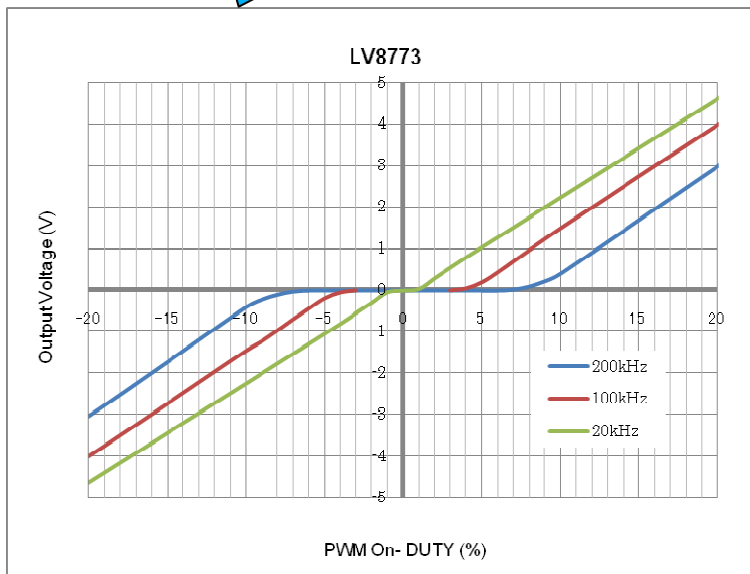
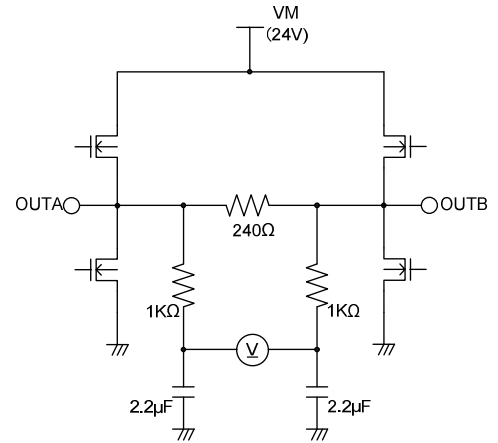
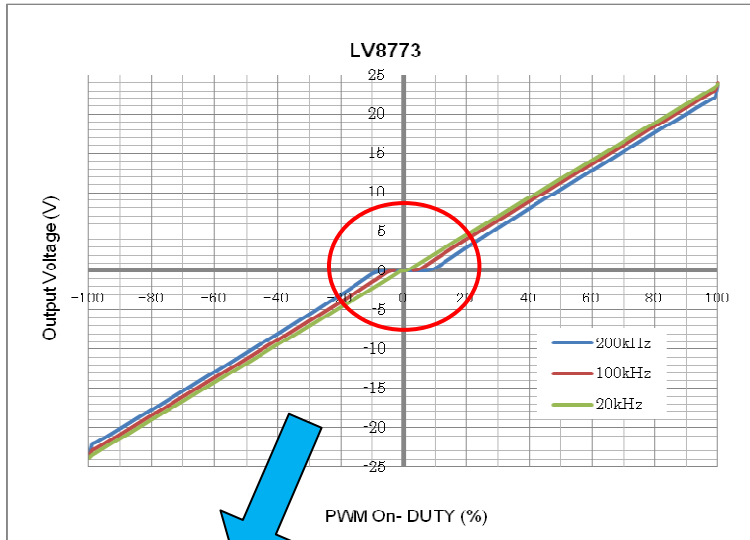

Figure 16. PWM control characteristic

The following show a waveform when it connected a motor.

(DC Motor)

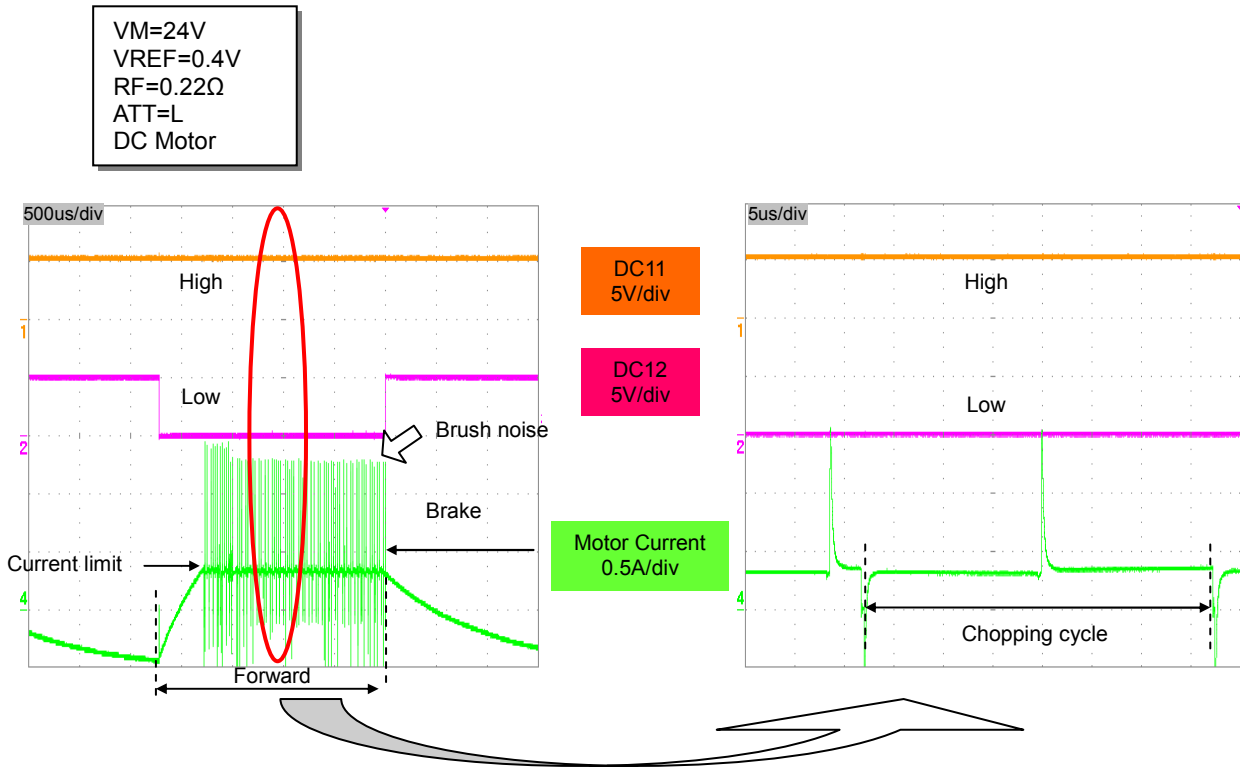

Figure 17. Setting constant-current control waveform (DC motor)

(Stepping Motor)

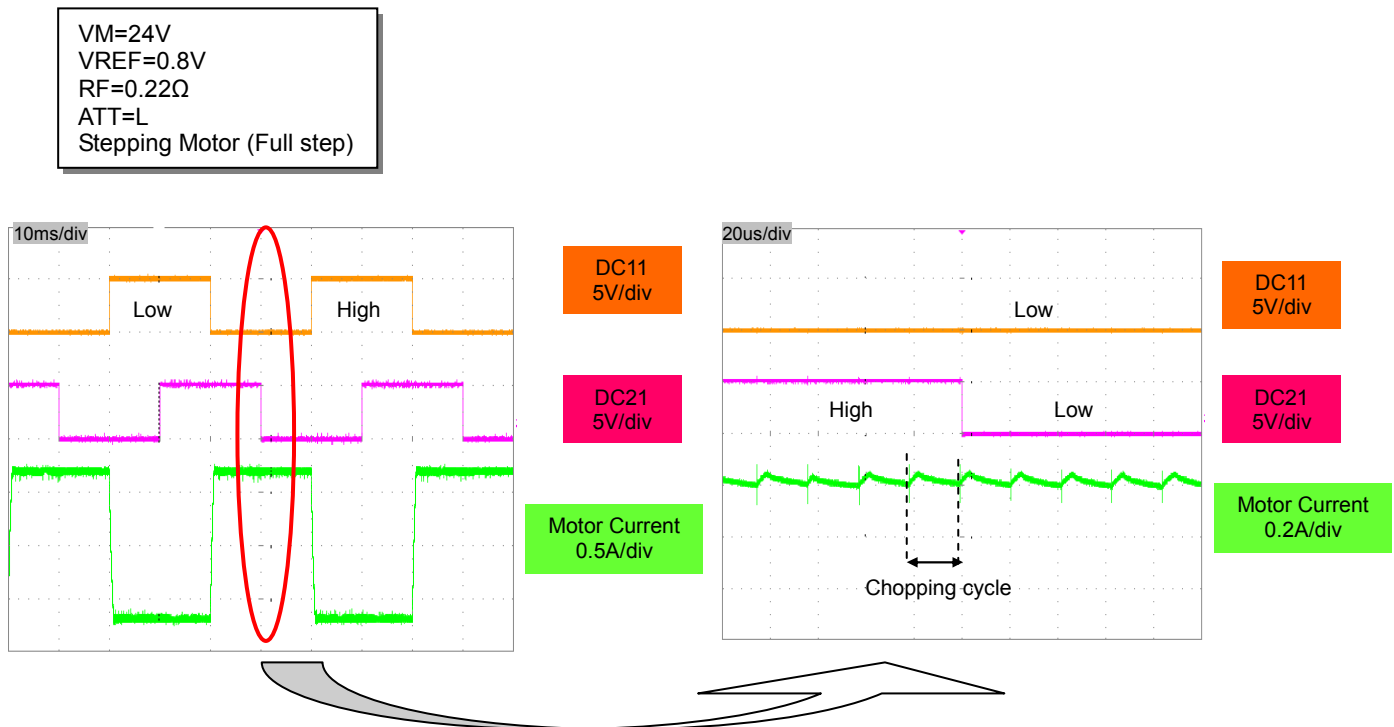

Figure 18. Setting constant-current control waveform (Stepping motor)

(9) Output short-circuit protection function

This IC incorporates an output short-circuit protection circuit that, when the output has been shorted by an event such as shorting to power or shorting to ground, sets the output to the standby mode and turns on the warning output in order to prevent the IC from being damaged. In the channels 1 and 2 operate independently. (Even if the output of channel 1 has been short-circuited, channel 2 will operate normally.)

(9-1) Output short-circuit detection operation

<p>VM short</p>	<ol style="list-style-type: none"> 1. High current flows if Tr3 and Tr4 are ON. 2. If RF voltage > setting voltage, then the mode switches to SLOW decay. 3. If the voltage between D and S of Tr4 exceeds the reference voltage for 2μs, short status is detected.
<p>GND short</p>	<p>(left schematic)</p> <ol style="list-style-type: none"> 1. High current flows if Tr3 and Tr4 are ON 2. If the voltage between D and S of Tr1 exceeds the reference voltage for 2μs, short status is detected. <p>(right schematic)</p> <ol style="list-style-type: none"> 1. Without going through RF resistor, current control does not operate and current will continue to increase in CHARGE mode. 2. If the voltage between D and S of Tr1 exceeds the reference voltage for 2μs, short status is detected.
<p>Load short</p>	<ol style="list-style-type: none"> 1. Without L load, high current flows. 2. If RF voltage > setting voltage, then the mode switches to SLOW decay. 3. During load short stay in SLOW decay mode, current does not flow and over current state is not detected. Then the mode is switched to FAST decay according to chopping cycle. 4. Since FAST state is short (≈1μs), switches to CHARGE mode before short is detected. 5. If voltage between D and S exceeds the reference voltage continuously during blanking time at the start of CHARGE mode (Tr1), CHARGE state is fixed (even if RF voltage exceeds the setting voltage, the mode is not switched to SLOW decay). After 2us or so, short is detected.

(9-2) Output short-circuit protection detect current (Reference value)

Short protection function operates when the following abnormal current flows into the output transistor.

Ta = 25°C (typ)

Output Transistor	Io
Upper-side Transistor	4.0A
Lower-side Transistor	3.6A

*RF=GND

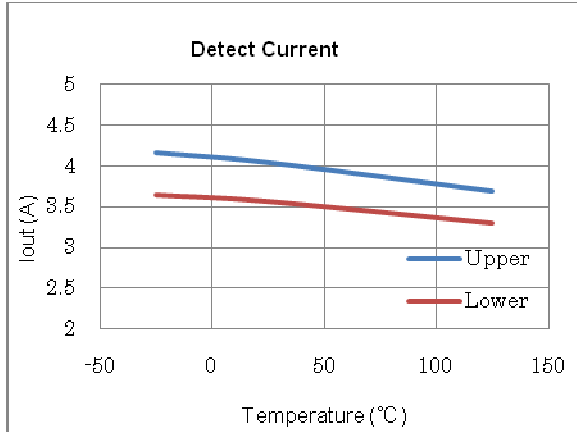

Figure 19. Detect current waveform

(9-3) Output short-circuits protection operation changeover function

Changeover to the output short-circuit protection of IC is made by the setting of EMM pin.

EMM	State
Low or Open	Latch method
High	Auto reset method

(9-4) Latch type

In the latch mode, when the output current exceeds the detection current level, the output is turned OFF, and this state is held.

The detection of the output short-circuited state by the IC causes the output short-circuits protection circuit to be activated.

When the short-circuited state continues for the period of time set using the internal timer (approximately 2μs), the output in which the short-circuiting has been detected is first set to OFF. After this, the output is set to ON again as soon as the timer latch time (Tcem) described later has been exceeded, and if the short-circuited state is still detected, all the outputs of the channel concerned are switched to the standby mode, and this state is held.

This state is released by setting ST to low.

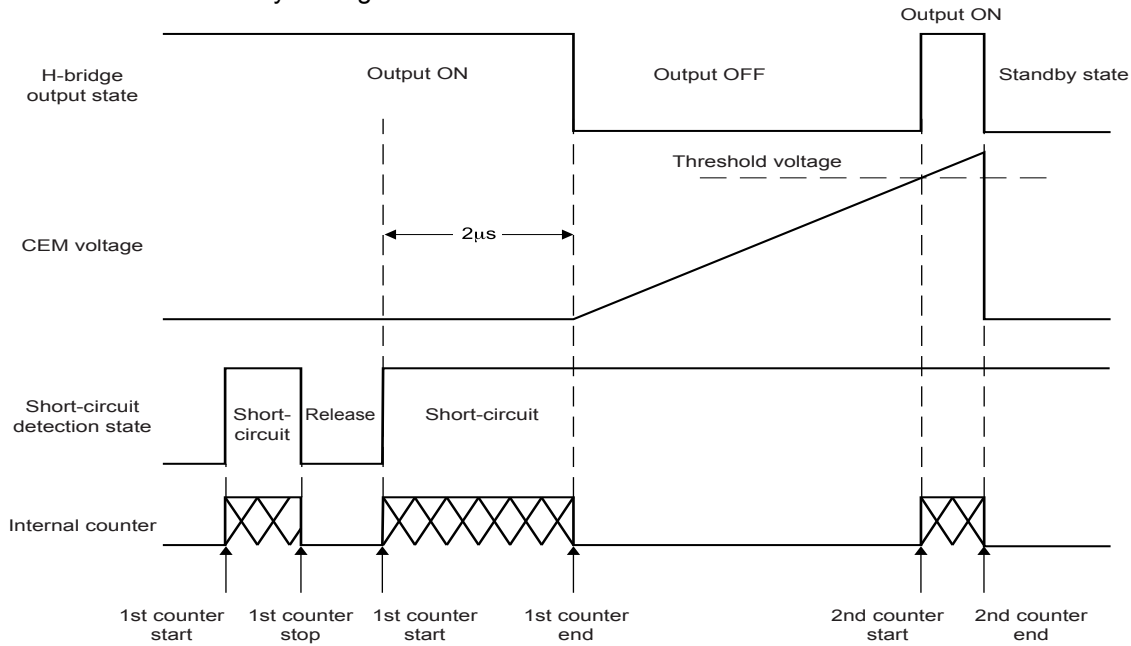

(9-5) Auto reset type

In the automatic reset mode, when the output current exceeds the detection current level, the output waveform changes to the switching waveform.

As with the latch system, when the output short-circuited state is detected, the short-circuit protection circuit is activated. When the operation of the short-circuit detection circuit exceeds the timer latch time (Tcem) described later, the output is changed over to the standby mode and is reset to the ON mode again in 2ms (typ). In this event, if the over current mode still continues, the switching mode described above is repeated until the over current mode is canceled.

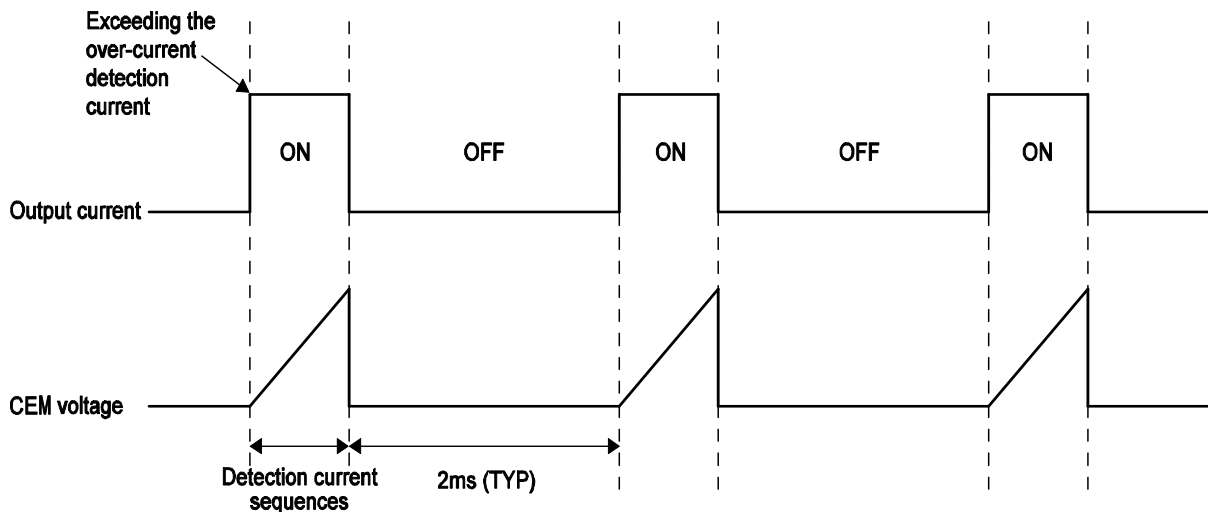

(9-6) Timer latch time (Tcem)

The time taken for the output to be set to OFF when the output has been short-circuited can be set using capacitor Ccem, connected between the CEM pin and GND. The value of capacitor Ccem is determined by the formula given below.

Timer latch: Tcem $T_{cem} \approx C_{cem} \times V_{t_{cem}} / I_{cem}$ [sec]
 Vt_{cem}: Comparator threshold voltage, typ 1V
 I_{cem}: CEM pin charge current, typ 10μA

When you do not connect CEM capacitor (CEM=open) and short state continues for 2us, output turns OFF. Standby mode is set if short state continues even after the output is turn ON again.

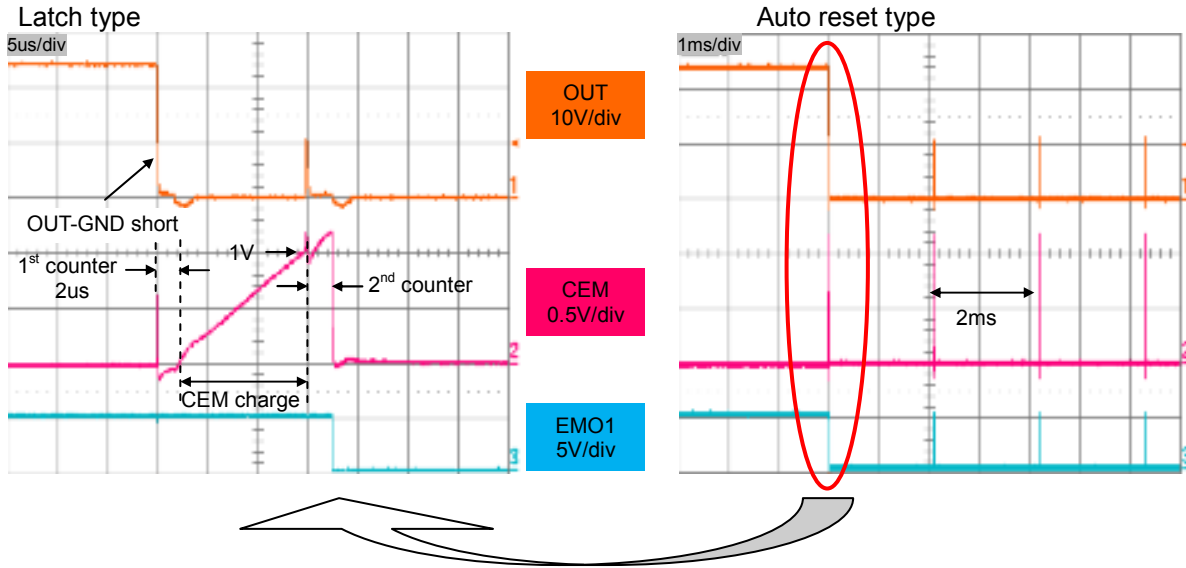

Figure 20. CEM operation waveform

(9-7) Unusual condition warning output pins (EMO1, EMO2)

The LV8773 is provided with the EMO pin which notifies the CPU of an unusual condition if the protection circuit operates by detecting an unusual condition of the IC. This pin is of the open-drain output type and when an unusual condition is detected, the EMO output is placed in the ON (EMO = Low) state. The EMO1 pin and the EMO2 pin output unusual condition on 2ch side/ 1ch side respectively.

Furthermore, the EMO (EMO2) pin is placed in the ON state when one of the following conditions occurs.

1. Shorting-to-power, shorting-to-ground, or shorting-to-load occurs at the output pin and the output short-circuit protection circuit is activated.
2. The IC junction temperature rises and the thermal protection circuit is activated.

Unusual condition	EMO1	EMO2
Channel 1 short-circuit detected	ON	-
Channel 2 short-circuit detected	-	ON
Overheating condition detected	ON	ON

(10) Charge Pump Circuit

When the ST pin is set high, the charge pump circuit operates and the VG pin voltage is boosted from the VM voltage to the VM + VREG5 voltage.

Begin the drive of the motor after the time of t_{ONG} or more because it doesn't turn on the output if the voltage of the VG pin is not pressured to VM+4V or more.

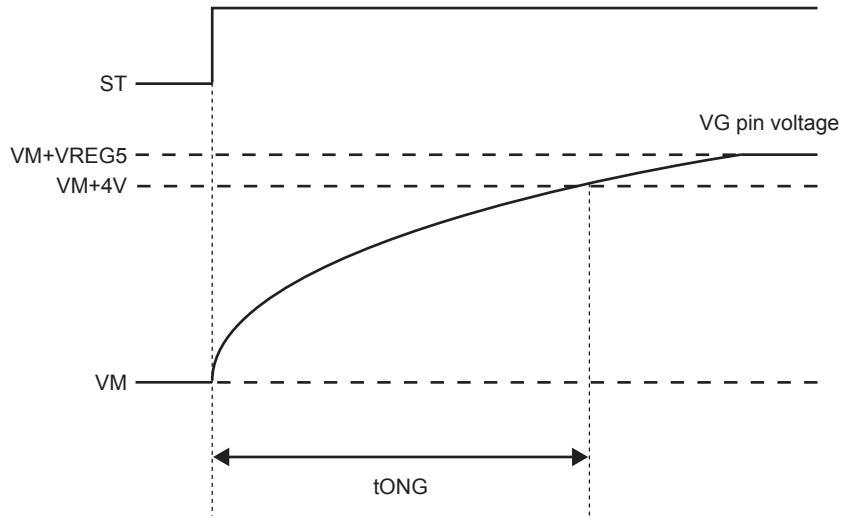

VG Pin Voltage Schematic View

VG voltage is used to drive upper output FET and VREG5 voltage is used to drive lower output FET. Since VG voltage is equivalent to the addition of VM and VREG5 voltage, VG capacitor should allow higher voltage.

The capacitor between CP1 and CP2 is used to boost charge pump. Since CP1 oscillates with 0V↔VREG5 and CP2 with VM↔VM + VREG5, make sure to allow enough capacitance between CP1 and CP2.

Since the capacitance is variable depends on motor types and driving methods, please check with your application before you define constant to avoid ripple on VG voltage.

(Recommended value) VG: 0.1uF
CP1-CP2: 0.1uF

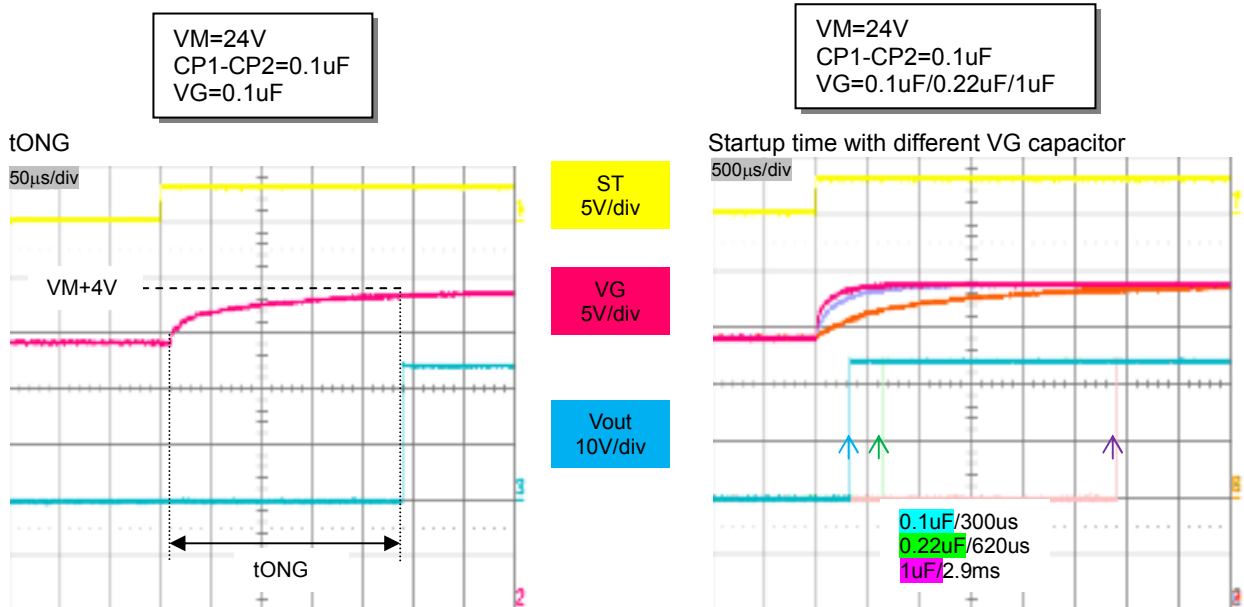

Figure 21. VG voltage pressure waveform

(11) Thermal shutdown function

The thermal shutdown circuit is incorporated and the output is turned off when junction temperature T_j exceeds 180°C and the abnormal state warning output is turned on. As the temperature falls by hysteresis, the output turned on again (automatic restoration).

The thermal shutdown circuit does not guarantee the protection of the final product because it operates when the temperature exceed the junction temperature of $T_{j\text{max}}=150^{\circ}\text{C}$.

$T_{\text{TSD}} = 180^{\circ}\text{C}$ (typ)

$\Delta T_{\text{TSD}} = 40^{\circ}\text{C}$ (typ)

Application Circuit Example

- Stepping motor driver circuit

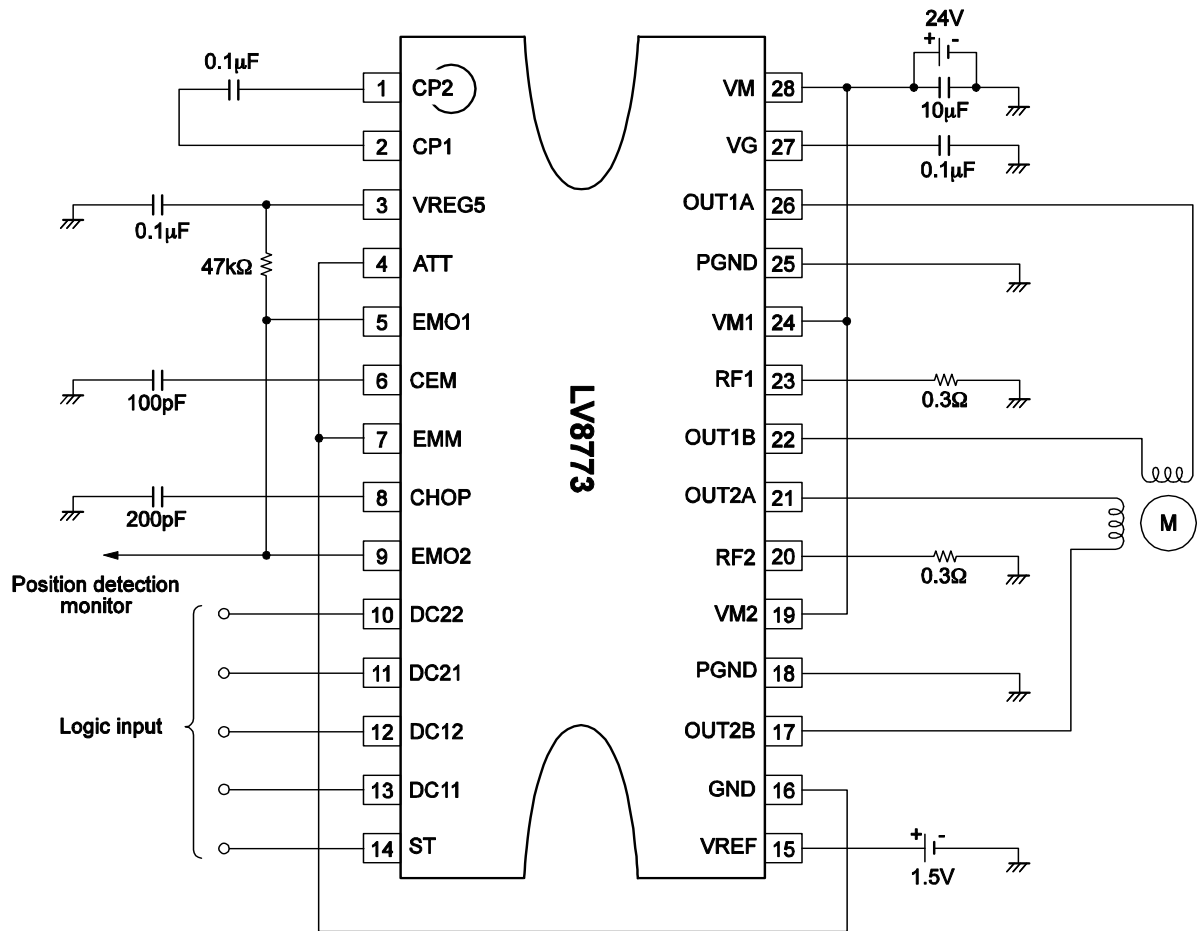

The formulae for setting the constants in the examples of the application circuits above are as follows:

Constant current (100%) setting

When VREF = 1.5V

$$I_{OUT} = VREF/5/RF \text{ resistance}$$

$$= 1.5V/5/0.3\Omega = 1.0A$$

Chopping frequency setting

$$F_{chop} = I_{chop}/(C_{chop} \times V_{tchop} \times 2)$$

$$= 10\mu A/(220pF \times 0.5V \times 2) = 45.4 \text{ kHz}$$

Timer latch time when the output is short-circuited

$$T_{cem} = C_{cem} \times V_{tcem}/I_{cem}$$

$$= 100pF \times 1V/10\mu A = 10\mu s$$

LV8773

- DC motor driver circuit (Constant current control function is used.)

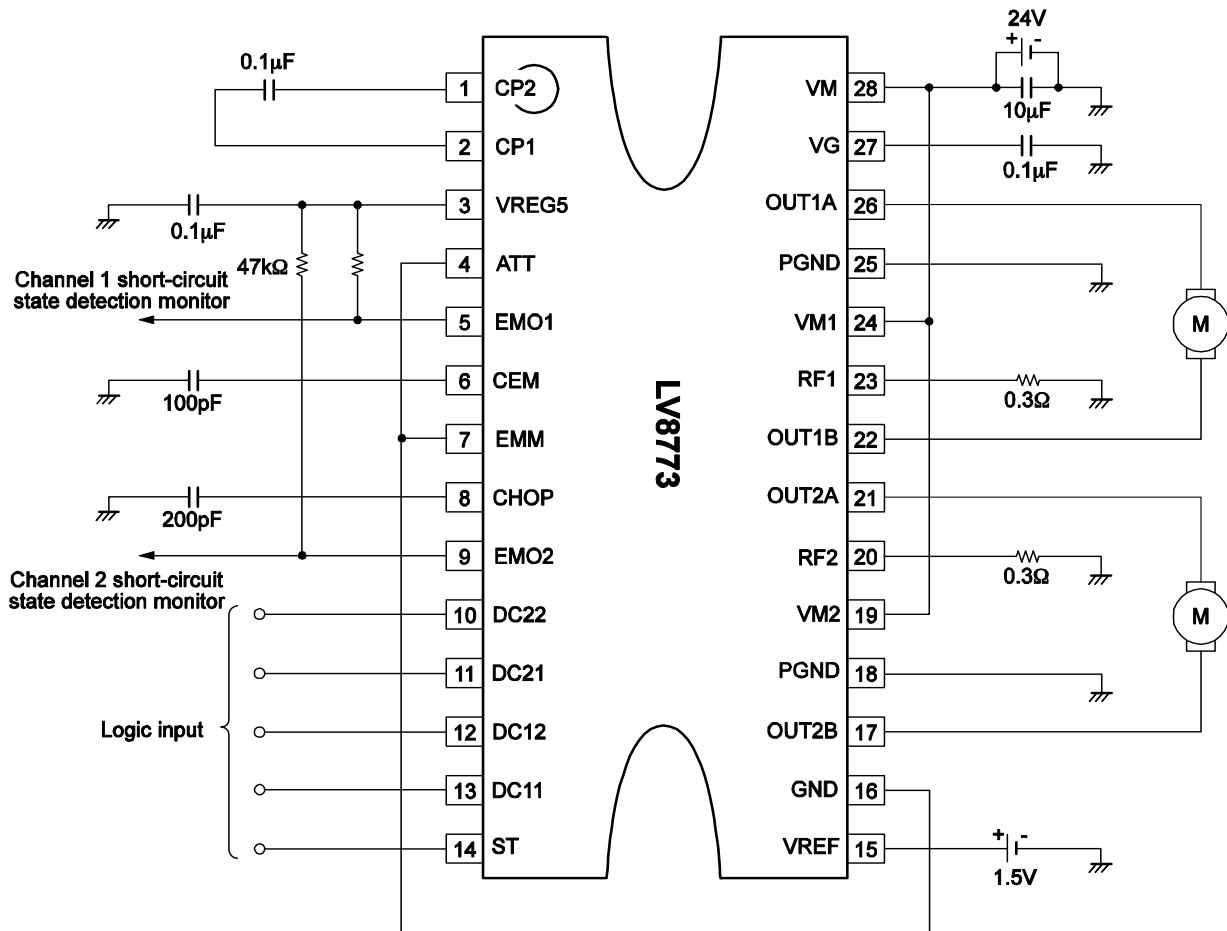

The formulae for setting the constants in the examples of the application circuits above are as follows:

Constant current limit (100%) setting

When $V_{REF} = 1.5V$

$$I_{limit} = V_{REF} / 5 / R_F \text{ resistance} \\ = 1.5V / 5 / 0.3\Omega = 1.0A$$

Chopping frequency setting

$$f_{chop} = I_{chop} / (C_{chop} \times V_{tchop} \times 2) \\ = 10\mu A / (220pF \times 0.5V \times 2) = 45.4 \text{ kHz}$$

Timer latch time when the output is short-circuited

$$T_{cem} = C_{cem} \times V_{tcem} / I_{cem} \\ = 100pF \times 1V / 10\mu A = 10\mu s$$

LV8773

- DC motor parallel connection

By connecting OUT1A and OUT2A as well as OUT2A and OUT2B, you can double the current capability. However, you cannot use current limit function. (RF=GND)

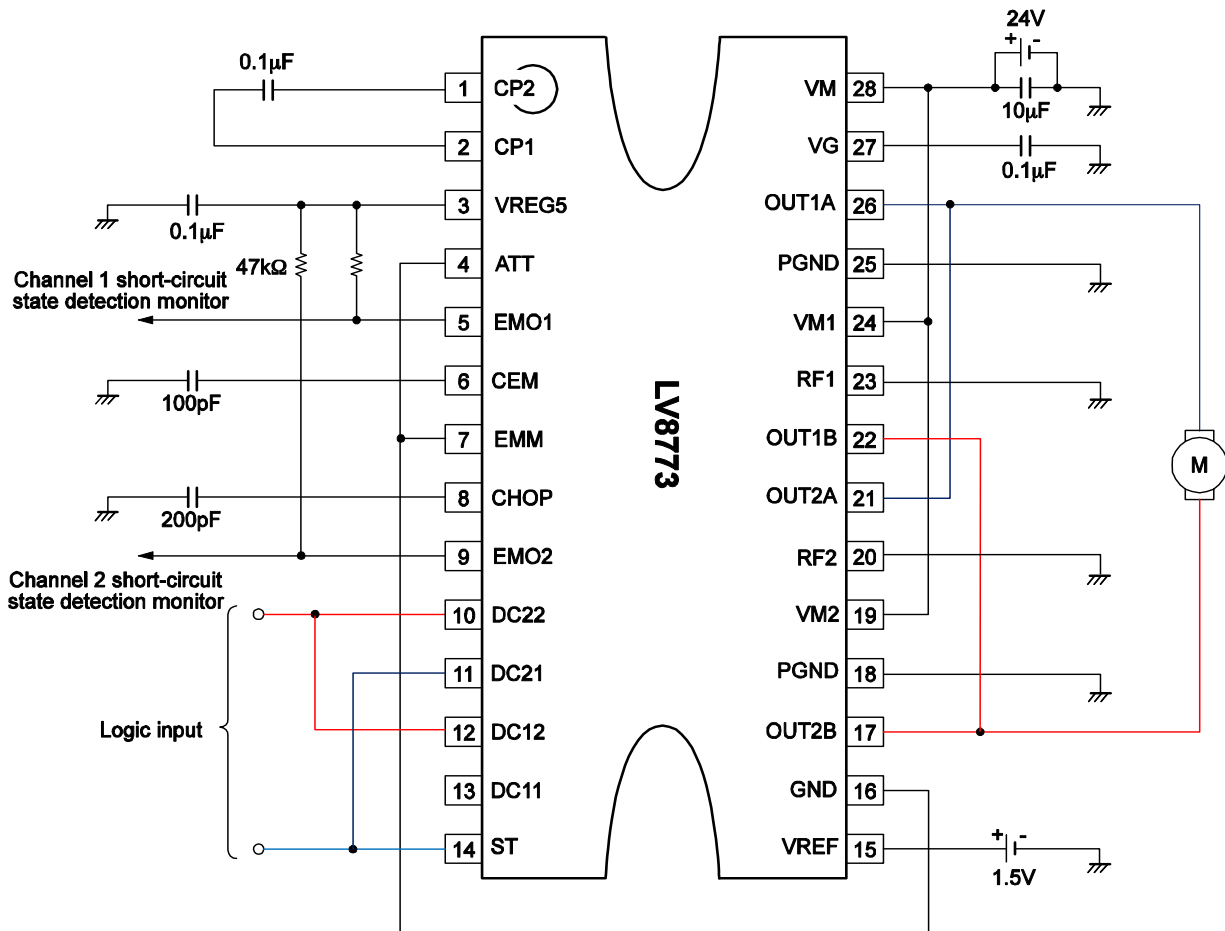

The formulae for setting the constants in the examples of the application circuits above are as follows:

Constant current limit (100%) setting

When $V_{REF} = 1.5V$

$$I_{limit} = V_{REF}/5 \\ = 1.5V/5 = 0.3A$$

Chopping frequency setting

$$f_{chop} = I_{chop}/(C_{chop} \times V_{tchop} \times 2) \\ = 10\mu A/(220pF \times 0.5V \times 2) = 45.4 \text{ kHz}$$

Timer latch time when the output is short-circuited

$$T_{cem} = C_{cem} \times V_{tcem}/I_{cem} \\ = 100pF \times 1V/10\mu A = 10\mu s$$

Allowable power dissipation

The pad on the backside of the IC functions as heatsink by soldering with the board. Since the heat-sink characteristics vary depends on board type, wiring and soldering, please perform evaluation with your board for confirmation.

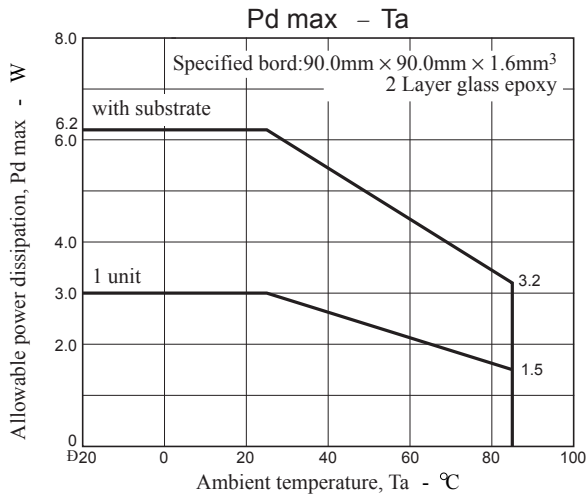

Substrate Specifications (Substrate recommended for operation of LV8773)

- Size : 90mm × 90mm × 1.6mm (two-layer substrate [2S0P])
- Material : Glass epoxy

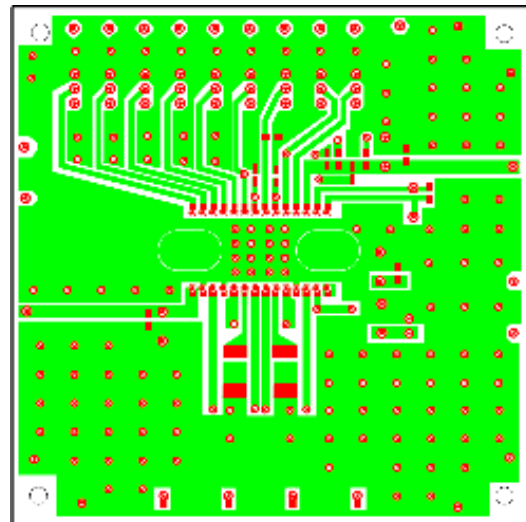
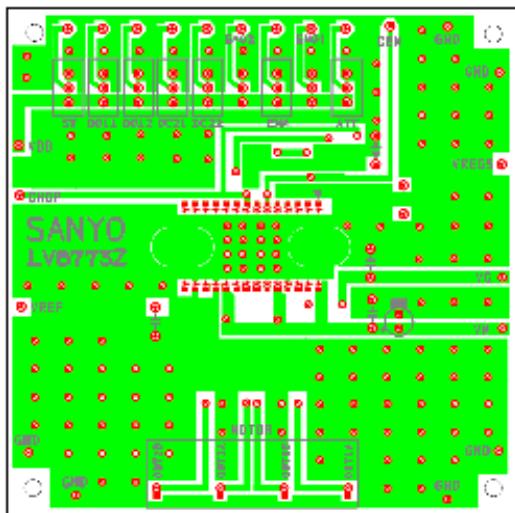

LV8773

Evaluation board

LV8773 (90.0mm×90.0mm×1.6mm, glass epoxy 2-layer board)

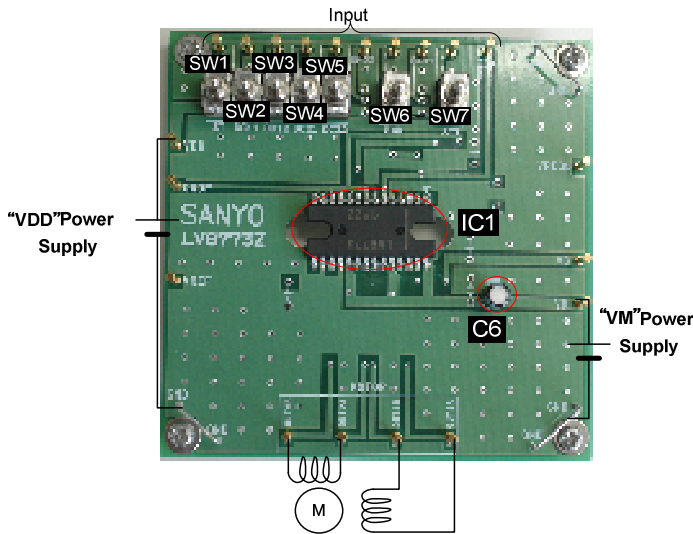

Front side

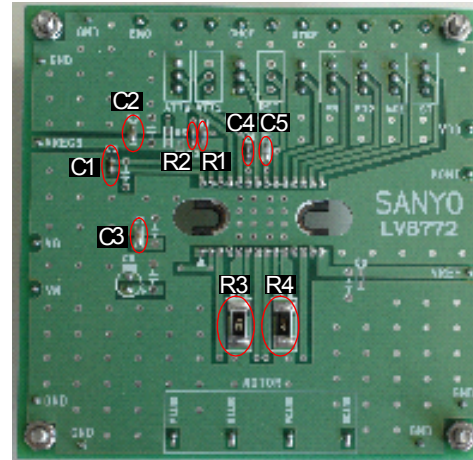

Back side

Bill of Materials for LV8773 Evaluation Board

Designator	Quantity	Description	Value	Tolerance	Footprint	Manufacturer	Manufacturer Part Number	Substitution Allowed	Lead Free
C1	1	Capacitor for Charge pump	0.1μF, 100V	±10%		Murata	GRM188R72A104KA35*	Yes	Yes
C2	1	Capacitor for Charge pump	0.1μF, 100V	±10%		Murata	GRM188R72A104KA35*	Yes	Yes
C3	1	5VREG stabilization Capacitor	0.1μF, 100V	±10%		Murata	GRM188R72A104KA35*	Yes	Yes
C4	1	Capacitor to set CEM timer	100pF, 50V	±5%		Murata	GRM1882C1H101JA01*	Yes	Yes
C5	1	Capacitor to set chopping frequency	180pF, 50V	±5%		Murata	GRM1882C1H181JA01*	Yes	Yes
C6	1	VM Bypass Capacitor	10μF, 50V	±20%		SUN Electronic Industries	50ME10HC	Yes	Yes
R1	1	Pull-up Resistor for terminal EMO1	47kΩ, 1/10W	±5%		KOA	RK73B1JT**473J	Yes	Yes
R2	1	Pull-up Resistor for terminal EMO2	47kΩ, 1/10W	±5%		KOA	RK73B1JT**473J	Yes	Yes
R3	1	Channel 1 output current detective Resistor	0.22Ω, 1W	±5%		ROHM	MCR100JZHJLR22	Yes	Yes
R4	1	Channel 2 output current detective Resistor	0.22Ω, 1W	±5%		ROHM	MCR100JZHJLR22	Yes	Yes
IC1	1	Motor Driver			DIP28HC (500mil)	SANYO semiconductors	LV8773	No	Yes
SW1-SW7	7	Switch	MS-621 C-A01			MIYAMA	MS-621C-A01	Yes	Yes
TP1-TP20	20	Test Point	ST-1-3			MAC8	ST-1-3	Yes	Yes

LV8773

Evaluation board circuit

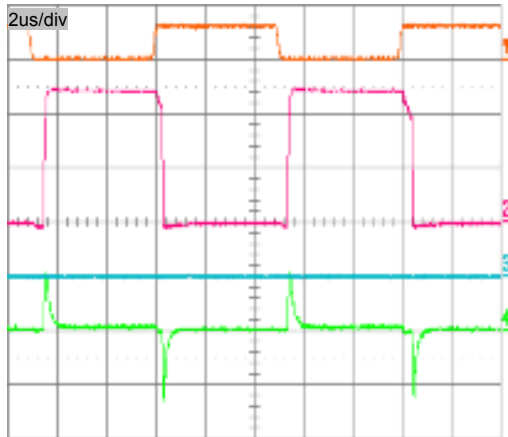
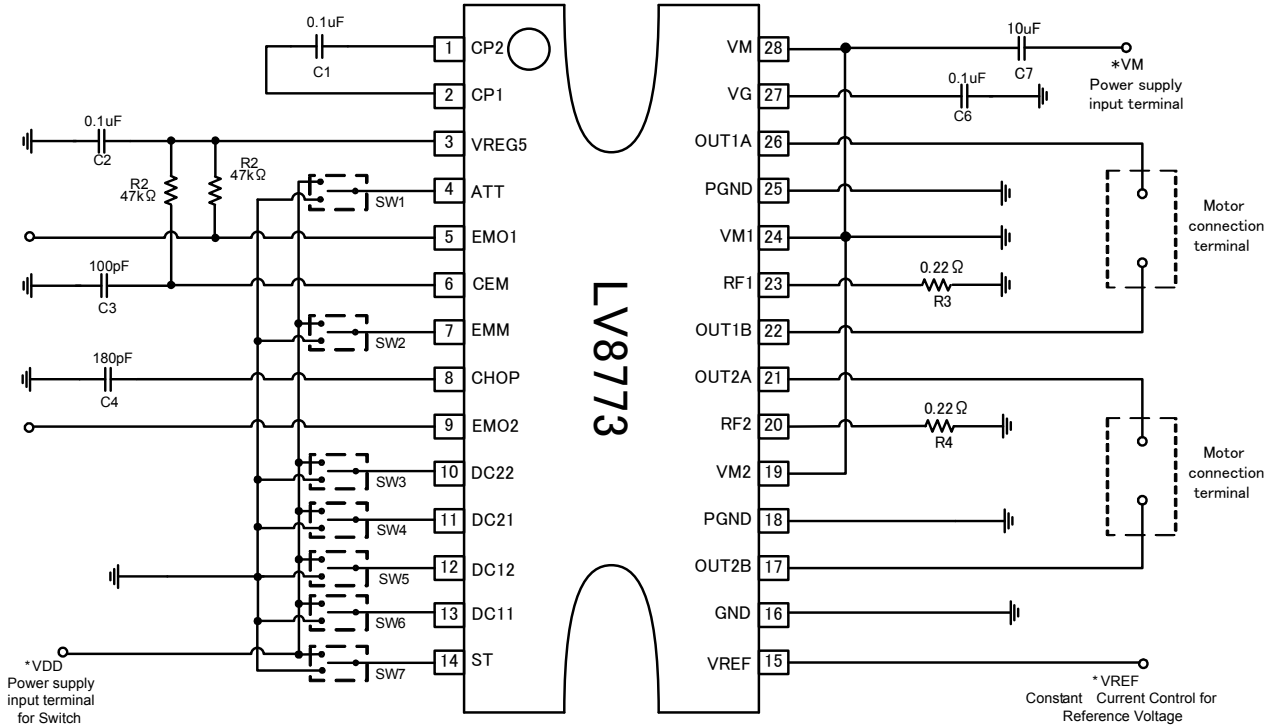

DC12
5V/div

OUT1A
10V/div

OUT1B
10V/div

Iout1
1A/div

【DC Motor(OUT1A-OUT1B)】
 VM=24V,VDD=5V,VREF=1.5V
 ST=H,EMM=L,ATT=L
 DC21=DC22=L
 DC11=H
 DC12=100 kHz (Duty50%)

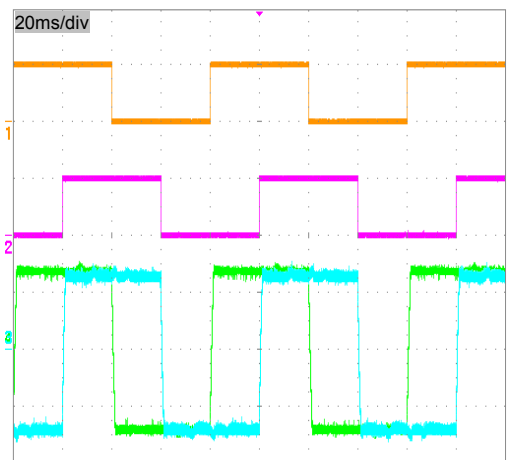

DC11
5V/div

DC21
5V/div

Iout1B
0.5A/div

Iout1A
0.5A/div

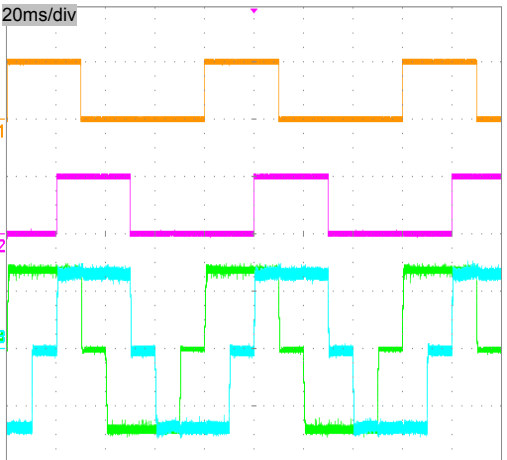

【Stepping Motor (Full step)】
 VM=24V,VDD=5V,VREF=0.8V,ST=H,EMM=L,ATT=L
 DC11=DC21=100Hz (Duty50%)
 DC12=the reverse pulse of DC11
 DC22=the reverse pulse of DC21

【Stepping Motor (half step)】
 VM=24V,VDD=5V,VREF=0.8V,ST=H,EMM=L,ATT=L
 DC11=DC21=200Hz (Duty37.5%)
 DC12=the reverse pulse of DC11
 DC22=the reverse pulse of DC21

Evaluation Board Manual

[Supply Voltage] VM (9 to 32V): Power Supply for LSI
 VREF (0 to 3V): Const. Current Control for Reference Voltage
 VDD (2 to 5V): Logic “High” voltage for toggle switch

[Toggle Switch State] Upper Side: High (VDD)
 Middle: Open, enable to external logic input
 Lower Side: Low (GND)

[Operation Guide]

For stepping motor control

1. **Initial Condition Setting:** Set “Open or Low” the switches.
2. **Motor Connection:** Connect the Motors between OUT1A and OUT1B, between OUT2A and OUT2B.
3. **Power Supply:** Supply DC voltage to VM, VREF and VDD.
4. **Ready for Operation from Standby State:** Turn “High” the ST terminal toggle switch. Channel 1 and 2 are into 2-phase excitement initial position (100%, -100%).
5. **Motor Operation:** Input the pulse signal into the terminal DC11, DC12, DC21, and DC22.
6. **Other Setting** (See Application Note for detail)
 - i. ATT: Motor current attenuation.
 - ii. EMM: Short circuit protection mode change.

For DC motor control

1. **Initial Condition Setting:** Set “Open or Low” the switches
2. **Motor Connection:** Connect the Motor(s) between OUT1A and OUT1B, between OUT2A and OUT2B.
3. **Power Supply:** Supply DC voltage to VM, VREF and VDD.
4. **Ready for Operation from Standby State:** Turn “High” the ST terminal toggle switch.
5. **Motor Operation:** Set DC11, DC12 and DC22 terminals according to the purpose.
6. **Other Setting** (See Application Note for detail)
 - i. ATT: Motor current attenuation.
 - ii. EMM: Short circuit protection mode change.

[Setting for External Component Value]

1. Constant Current (100%)
 At VREF=1.5V

$$I_{out} = VREF [V] / 5 / RF [ohm]$$

$$= 1.5 [V] / 5 / 0.22 [ohm]$$

$$= 1.36 [A]$$
2. Chopping Frequency

$$F_{chop} = I_{chop} [\mu A] / (C_{chop} \times V_t \times 2)$$

$$= 10 [\mu A] / (180 [pF] \times 0.5 [V] \times 2)$$

$$= 55 [kHz]$$
3. Short Protection Latch Time

$$T_{scp} = CEM [pF] \times V_T [V] / I_{chg} [\mu A]$$

$$= 100 [pF] \times 1 [V] / 10 [\mu A]$$

$$= 10 [\mu S]$$

Warning:**●Power supply connection terminal [VM, VM1, VM2]**

- ✓ Make sure to short-circuit VM, VM1 and VM2. For controller supply voltage, the internal regulator voltage of VREG5 (typ 5V) is used.
- ✓ Make sure that supply voltage does not exceed the absolute MAX ratings under no circumstance. Noncompliance can be the cause of IC destruction and degradation.
- ✓ Caution is required for supply voltage because this IC performs switching.
- ✓ The bypass capacitor of the power supply should be close to the IC as much as possible to stabilize voltage. Also if you intend to use high current or back EMF is high, please augment enough capacitance.

●GND terminal [GND, PGND]

- ✓ Since GND is the reference of the IC internal operation, make sure to connect to stable and the lowest possible potential. Since high current flows into PGND, connect it to one-point GND.

●Internal power supply regulator terminal [VREG5]

- ✓ VREG5 is the power supply for logic (typ 5V).
- ✓ When VM supply is powered and ST is "H", VREG5 operates.
- ✓ Please connect capacitor for stabilize VREG5. The recommendation value is 0.1uF.
- ✓ Since the voltage of VREG5 fluctuates, do not use it as reference voltage that requires accuracy.

●Input terminal

- ✓ The logic input pin incorporates pull-down resistor (100kΩ).
- ✓ When you set input pin to low voltage, please short it to GND because the input pin is vulnerable to noise.
- ✓ The input is TTL level (H: 2V or higher, L: 0.8V or lower).
- ✓ VREF pin is high impedance.

●OUT terminal [OUT1A, OUT1B, OUT2A, OUT2B]

- ✓ During chopping operation, the output voltage becomes equivalent to VM voltage, which can be the cause of noise. Caution is required for the pattern layout of output pin.
- ✓ The layout should be low impedance because driving current of motor flows into the output pin.
- ✓ Output voltage may boost due to back EMF. Make sure that the voltage does not exceed the absolute MAX ratings under no circumstance. Noncompliance can be the cause of IC destruction and degradation.

●Current sense resistor connection terminal [RF1, RF2]

- ✓ To perform constant current control, please connect resistor to RF pin.
- ✓ To perform saturation drive (without constant current control), please connect RF pin to GND.
- ✓ If RF pin is open, then short protector circuit operates. Therefore, please connect it to resistor or GND.
- ✓ The motor current flows into RF – GND line. Therefore, please connect it to common GND line and low impedance line.

- Any and all SANYO Semiconductor Co.,Ltd. products described or contained herein are, with regard to "standard application", intended for the use as general electronics equipment (home appliances, AV equipment, communication device, office equipment, industrial equipment etc.). The products mentioned herein shall not be intended for use for any "special application" (medical equipment whose purpose is to sustain life, aerospace instrument, nuclear control device, burning appliances, transportation machine, traffic signal system, safety equipment etc.) that shall require extremely high level of reliability and can directly threaten human lives in case of failure or malfunction of the product or may cause harm to human bodies, nor shall they grant any guarantee thereof. If you should intend to use our products for applications outside the standard applications of our customer who is considering such use and/or outside the scope of our intended standard applications, please consult with us prior to the intended use. If there is no consultation or inquiry before the intended use, our customer shall be solely responsible for the use.
- Specifications of any and all SANYO Semiconductor Co.,Ltd. products described or contained herein stipulate the performance, characteristics, and functions of the described products in the independent state, and are not guarantees of the performance, characteristics, and functions of the described products as mounted in the customer's products or equipment. To verify symptoms and states that cannot be evaluated in an independent device, the customer should always evaluate and test devices mounted in the customer's products or equipment.
- SANYO Semiconductor Co.,Ltd. assumes no responsibility for equipment failures that result from using products at values that exceed, even momentarily, rated values (such as maximum ratings, operating condition ranges, or other parameters) listed in products specifications of any and all SANYO Semiconductor Co.,Ltd. products described or contained herein.
- SANYO Semiconductor Co.,Ltd. strives to supply high-quality high-reliability products, however, any and all semiconductor products fail or malfunction with some probability. It is possible that these probabilistic failures or malfunction could give rise to accidents or events that could endanger human lives, trouble that could give rise to smoke or fire, or accidents that could cause damage to other property. When designing equipment, adopt safety measures so that these kinds of accidents or events cannot occur. Such measures include but are not limited to protective circuits and error prevention circuits for safe design, redundant design, and structural design.
- In the event that any or all SANYO Semiconductor Co.,Ltd. products described or contained herein are controlled under any of applicable local export control laws and regulations, such products may require the export license from the authorities concerned in accordance with the above law.
- No part of this publication may be reproduced or transmitted in any form or by any means, electronic or mechanical, including photocopying and recording, or any information storage or retrieval system, or otherwise, without the prior written consent of SANYO Semiconductor Co.,Ltd.
- Any and all information described or contained herein are subject to change without notice due to product/technology improvement, etc. When designing equipment, refer to the "Delivery Specification" for the SANYO Semiconductor Co.,Ltd. product that you intend to use.
- Information (including circuit diagrams and circuit parameters) herein is for example only; it is not guaranteed for volume production.
- Upon using the technical information or products described herein, neither warranty nor license shall be granted with regard to intellectual property rights or any other rights of SANYO Semiconductor Co.,Ltd. or any third party. SANYO Semiconductor Co.,Ltd. shall not be liable for any claim or suits with regard to a third party's intellectual property rights which has resulted from the use of the technical information and products mentioned above.

This catalog provides information as of June, 2011. Specifications and information herein are subject to change without notice.