

# NB3L208KMNGEVB

## NB3L208K Evaluation Board User's Manual



ON Semiconductor®

[www.onsemi.com](http://www.onsemi.com)

### Introduction

The NB3L208K is a differential 1:8 Clock fanout buffer with High-speed Current Steering Logic (HCSL) outputs. Inputs can directly accept differential LVPECL, LVDS and HCSL signals. Single-ended LVPECL, HCSL, LVCMOS, or LVTTTL levels are accepted with a proper external  $V_{TH}$  reference supply. These signals will be translated to HCSL and eight identical copies of Clock will be distributed, operating up to 350 MHz.

This manual should be used in conjunction with the device datasheet, which contains full technical details on the device specifications and operation.

### EVAL BOARD USER'S MANUAL

This evaluation board manual contains:

- Information on the NB3L208K Evaluation Board
- Block Diagram and Board Schematic
- Assembly Instructions
- Test and Measurement Setup Procedures
- Bill of Materials

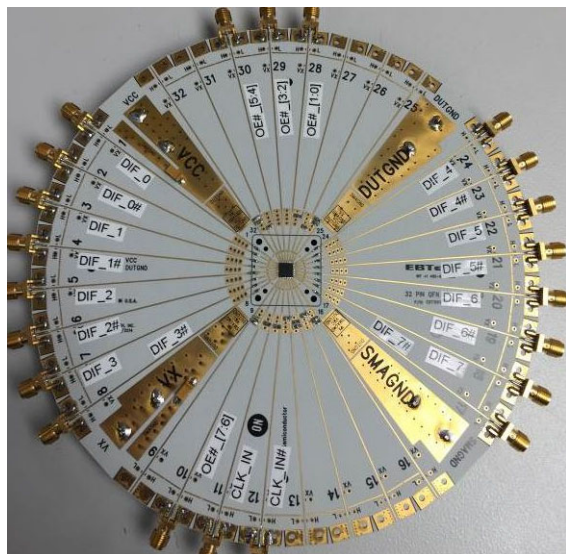

Top View

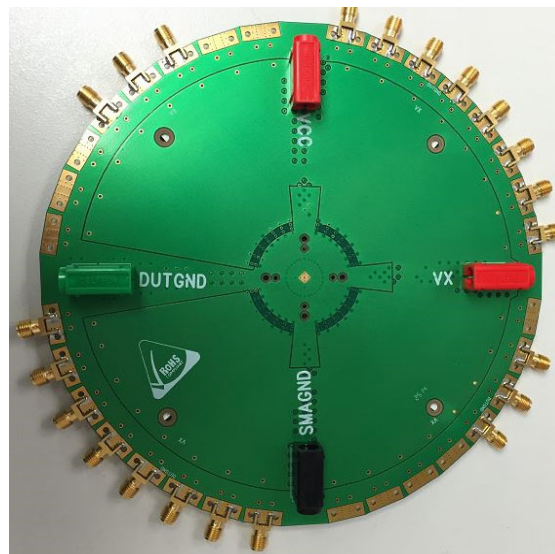

Bottom View

Figure 1. NB3L208KMNGEVB Top and Bottom View

# NB3L208KMNGEVB

## QUICK START LAB SET-UP USER'S GUIDE

### Equipment Required

1. DC Power Supply
2. Oscilloscope
3. Phase Noise Analyzer
4. Connectors for DC Power Supply
5. 50-Ω SMA Connectors for I/Os

### Block Diagram

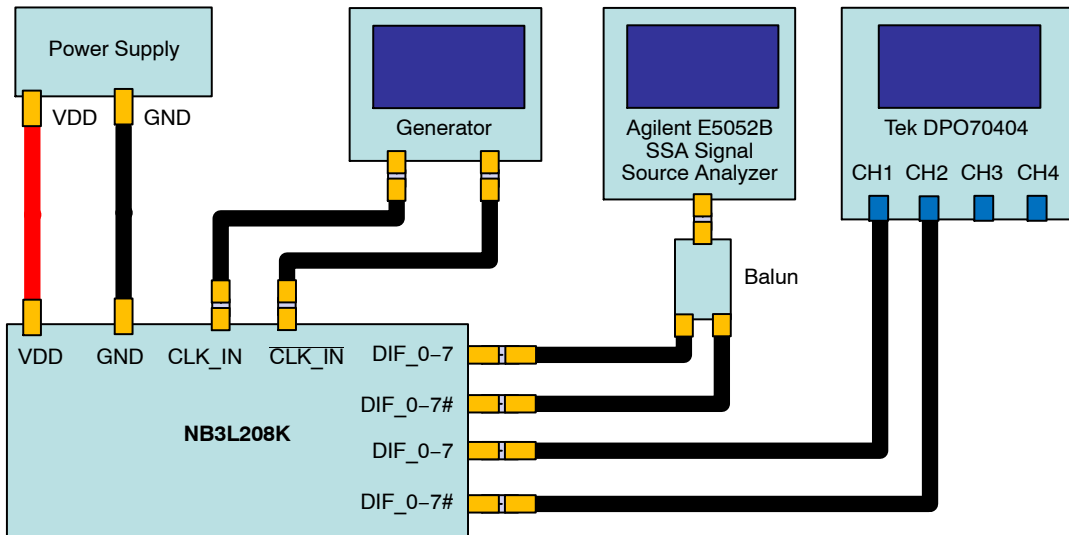

Note: Balun Connected to Outputs Only during Phase Noise Testing.

Figure 2. Time and Frequency Domain Block Diagram

### Power Supplies

Each VDD, VDD\_0 (VX on board), GND\_0 (DUTGND on board) and SMAGND power supply has a separate side-launch banana jack located on bottom side of the test board (as shown in Figure 1).

### HCSL Outputs

HCSL outputs are typically loaded and terminated with a series resistor ( $R_{\text{SERIES}} = 33\text{-}\Omega$  and  $50\text{-}\Omega$  to ground). This can be easily accomplished by connecting the HCSL outputs to the  $50\text{-}\Omega$  internal impedance in the oscilloscope. There are on-board  $R_{\text{SERIES}} = 33\text{-}\Omega$  termination resistors installed for each HCSL output.

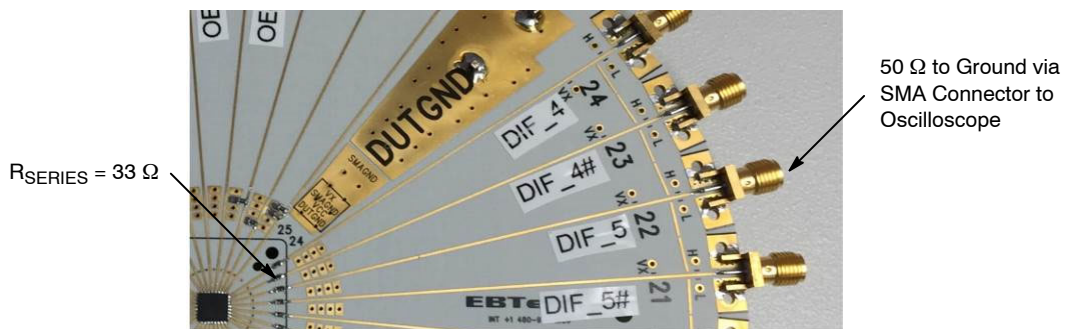

Figure 3. Set-Up for HCSL Output

# NB3L208KMNGEVB

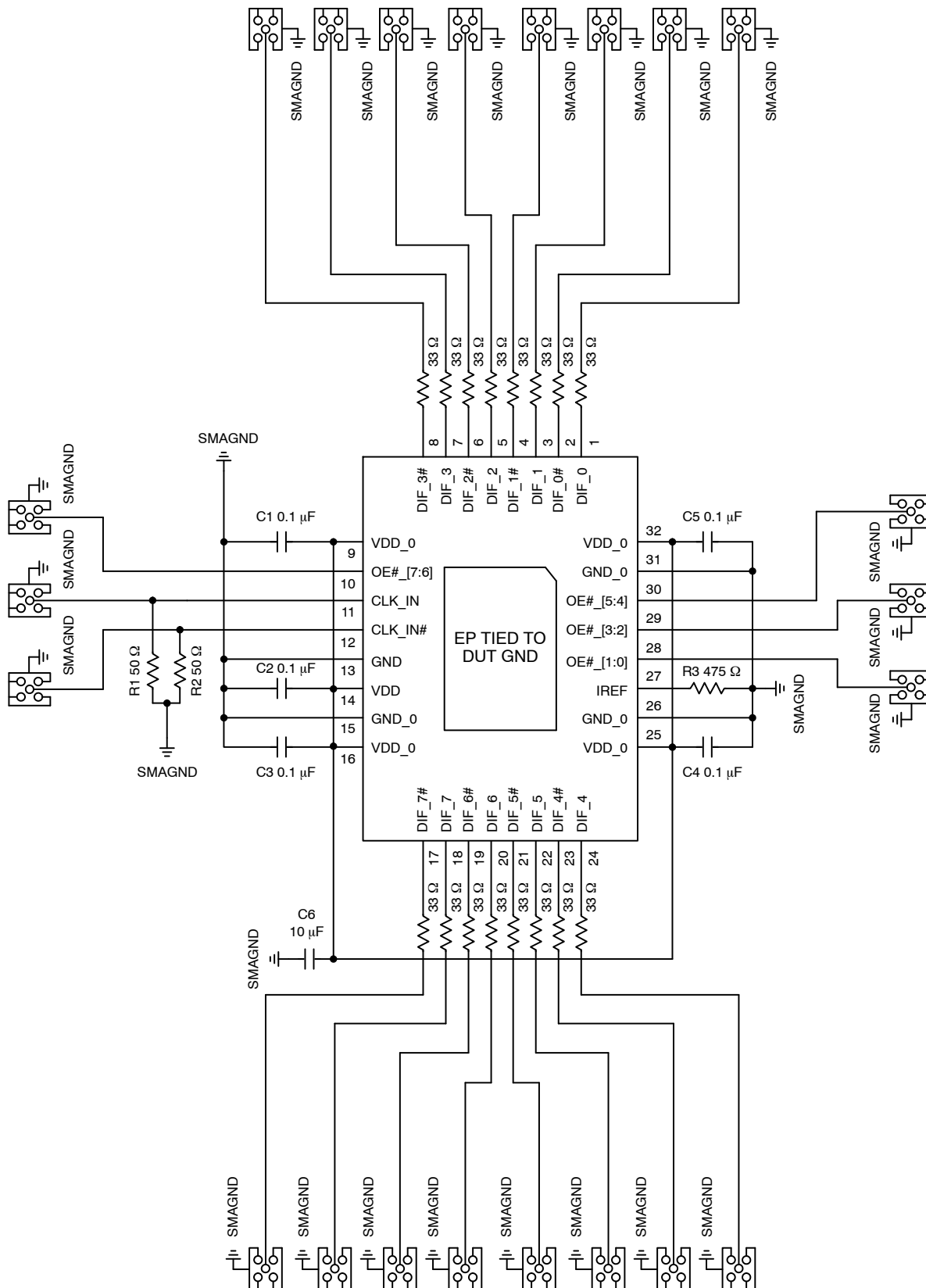

Figure 4. NB3L208KEVB Schematic

## NB3L208KMNGEVB

### Test and Measurement Setup Procedures

1. Connect VDD and VDD\_0 (VX on board) of the NB3L208K to DC source with power supply cables (do not turn power on, yet).
2. Connect SMAGND and DUTGND to the appropriate DC source. For differential HCSL inputs, both SMAGND and DUTGND are connected together.
3. Connect the outputs of the generator to the CLK\_IN & CLK\_IN# inputs with 50- $\Omega$  connectors. For phase noise test, low noise generator is required to ensure the best additive RMS Phase jitter of the DUT.
4. Connect the DIF\_n/DIF\_n# outputs to the appropriate oscilloscope channel. The board does not have 50- $\Omega$  output termination, thus use of the probes with 50- $\Omega$  termination is required.

### Power-Up Sequence

1. Turn on DUT power supply.
2. Setup the generator  $V_{IH}$ ,  $V_{IL}$  levels to set up the inputs to desired inputs levels, i.e differential LVPECL, LVDS, and HCSL signals or Single-ended LVPECL, HCSL, LVCMOS, or LVTTL. For differential HCSL inputs,  $V_{IL} = 0$  V and  $V_{IH} = 700$  mV.
3. Monitor DIF\_n/DIF\_n# outputs on oscilloscope.

# NB3L208KMNGEVB

## BILL OF MATERIALS

**Table 1. NB3L208KMNGEVB BILL OF MATERIALS**

Component	Qty.	Description	Manufacturer	Part Number	Web Site
SMA Connector	22	Edge Mount	Johnson	142-0711-821	
Banana Jack Connector	2	Red – Side Launch	Deltron	571-0500	Mouser #164-6219
Banana Jack Connector	1	Black – Side Launch	Deltron	571-0100	Mouser #164-6218
Banana Jack Connector	1	Green – Side Launch	Deltron		Mouser
Chip Resistor	9	0-Q 0603	Vishay	CRCW06030000Z0EA	Digi-Key 541-0.0GTR-ND
Chip Resistor	16	33-Q 0402	Panasonic	ERJ-2RKF33R0X	Digi-Key ERJ-2RKF33R0X
Chip Resistor	4	50-Q, 0603	Vishay	FC0603E50R0BTBST1	Digi-Key FC0603-50BFTR-ND
Chip Resistor	1	475-Q 0603	Vishay	TNPW0603475RBEEA	Digi-Key 541-2027-2-ND
Capacitor	2	10 $\mu$ F $\pm$ 10%, Case "C" 25 V or 16 V	KEMET	T491C106K025AT T491C106K016AS	
Chip Capacitor	5	0.1 $\mu$ F $\pm$ 10%, 0603	AVX	0603C104KAT2A	<a href="http://www.avx.com">www.avx.com</a> Digi-Key 478-1129-1-ND
Stand-Off	4	Standoff, 4-40 1/4 $\times$ 5/8	Keystone	1808	Digi-Key 1808K-ND
Screw	4	Screw, 4-40 $\times$ 0.25, PHP	Building Fasteners	PMS 440 0025 PH	Digi-Key H342-ND
Evaluation Board	1	NB3L208KEVB QFN-32 Evaluation Board	ON Semiconductor	NB3L208KEVB	
Device Under Test	1	DUT	ON Semiconductor	NB3L208K	<a href="http://www.onsemi.com">www.onsemi.com</a>

NOTE: Components are available through most distributors, i.e. [www.newark.com](http://www.newark.com), [www.Digikey.com](http://www.Digikey.com).

ON Semiconductor and the ON Semiconductor logo are trademarks of Semiconductor Components Industries, LLC dba ON Semiconductor or its subsidiaries in the United States and/or other countries. ON Semiconductor owns the rights to a number of patents, trademarks, copyrights, trade secrets, and other intellectual property. A listing of ON Semiconductor's product/patent coverage may be accessed at [www.onsemi.com/site/pdf/Patent-Marking.pdf](http://www.onsemi.com/site/pdf/Patent-Marking.pdf). ON Semiconductor is an Equal Opportunity/Affirmative Action Employer. This literature is subject to all applicable copyright laws and is not for resale in any manner.

The evaluation board/kit (research and development board/kit) (hereinafter the "board") is not a finished product and is as such not available for sale to consumers. The board is only intended for research, development, demonstration and evaluation purposes and should as such only be used in laboratory/development areas by persons with an engineering/technical training and familiar with the risks associated with handling electrical/mechanical components, systems and subsystems. This person assumes full responsibility/liability for proper and safe handling. Any other use, resale or redistribution for any other purpose is strictly prohibited.

The board is delivered "AS IS" and without warranty of any kind including, but not limited to, that the board is production-worthy, that the functions contained in the board will meet your requirements, or that the operation of the board will be uninterrupted or error free. ON Semiconductor expressly disclaims all warranties, express, implied or otherwise, including without limitation, warranties of fitness for a particular purpose and non-infringement of intellectual property rights.

ON Semiconductor reserves the right to make changes without further notice to any board.

You are responsible for determining whether the board will be suitable for your intended use or application or will achieve your intended results. Prior to using or distributing any systems that have been evaluated, designed or tested using the board, you agree to test and validate your design to confirm the functionality for your application. Any technical, applications or design information or advice, quality characterization, reliability data or other services provided by ON Semiconductor shall not constitute any representation or warranty by ON Semiconductor, and no additional obligations or liabilities shall arise from ON Semiconductor having provided such information or services.

The boards are not designed, intended, or authorized for use in life support systems, or any FDA Class 3 medical devices or medical devices with a similar or equivalent classification in a foreign jurisdiction, or any devices intended for implantation in the human body. Should you purchase or use the board for any such unintended or unauthorized application, you shall indemnify and hold ON Semiconductor and its officers, employees, subsidiaries, affiliates, and distributors harmless against all claims, costs, damages, and expenses, and reasonable attorney fees arising out of, directly or indirectly, any claim of personal injury or death associated with such unintended or unauthorized use, even if such claim alleges that ON Semiconductor was negligent regarding the design or manufacture of the board.

This evaluation board/kit does not fall within the scope of the European Union directives regarding electromagnetic compatibility, restricted substances (RoHS), recycling (WEEE), FCC, CE or UL, and may not meet the technical requirements of these or other related directives.

**FCC WARNING** – This evaluation board/kit is intended for use for engineering development, demonstration, or evaluation purposes only and is not considered by ON Semiconductor to be a finished end product fit for general consumer use. It may generate, use, or radiate radio frequency energy and has not been tested for compliance with the limits of computing devices pursuant to part 15 of FCC rules, which are designed to provide reasonable protection against radio frequency interference. Operation of this equipment may cause interference with radio communications, in which case the user shall be responsible, at its expense, to take whatever measures may be required to correct this interference.

ON Semiconductor does not convey any license under its patent rights nor the rights of others.

**LIMITATIONS OF LIABILITY:** ON Semiconductor shall not be liable for any special, consequential, incidental, indirect or punitive damages, including, but not limited to the costs of requalification, delay, loss of profits or goodwill, arising out of or in connection with the board, even if ON Semiconductor is advised of the possibility of such damages. In no event shall ON Semiconductor's aggregate liability from any obligation arising out of or in connection with the board, under any theory of liability, exceed the purchase price paid for the board, if any.

For more information and documentation, please visit [www.onsemi.com](http://www.onsemi.com).

---

## PUBLICATION ORDERING INFORMATION

### LITERATURE FULFILLMENT:

Email Requests to: [orderlit@onsemi.com](mailto:orderlit@onsemi.com)

ON Semiconductor Website: [www.onsemi.com](http://www.onsemi.com)

### TECHNICAL SUPPORT

North American Technical Support:

Voice Mail: 1 800-282-9855 Toll Free USA/Canada

Phone: 011 421 33 790 2910

Europe, Middle East and Africa Technical Support:

Phone: 00421 33 790 2910

For additional information, please contact your local Sales Representative