

# NCV7425EVB

## NCV7425 LIN Transceiver with Voltage Regulator and Reset Pin Evaluation Board User's Manual



ON Semiconductor®

<http://onsemi.com>

### EVAL BOARD USER'S MANUAL

#### Introduction

This document describes the NCV7425EVB board for the ON Semiconductor NCV7425 LIN Transceiver with Voltage Regulator and Reset pin. The functionality and major parameters can be evaluated with the NCV7425EVB board.

The NCV7425 is a fully featured local interconnect network (LIN) transceiver designed to interface between a LIN protocol controller and the physical bus.

The NCV7425 LIN device is a member of the in-vehicle networking (IVN) transceiver family of ON Semiconductor that integrates a LIN v2.1 physical transceiver and a low-drop voltage regulator. It is designed to work in harsh automotive environment and is submitted to the TS16949 qualification flow.

#### Evaluation Board Features

- One-row Pin Header Connecting to all Circuit Signals Enables Easy Insertion of the Evaluation Board into a more Complex Application Setup. The Header can be Alternatively Assembled either Perpendicular or Parallel with the Board Plane
- Oscilloscope Test-points on All Circuit Signals
- Reverse Protection and Decoupling on the Main (Battery) Supply
- Decoupling on VCC Regulator Output
- Additional Pull-up Resistor on the RSTN Open-drain Output
- Filtering Circuit on the Switch-monitoring WAKE Input
- On-board Local Wakeup Switch
- LIN-bus Termination and Optional ESD Protection
- Good Thermal Connection of the Circuit's Exposed Pad to the Bottom Ground Plane

#### NCV7425 Key Features

- LIN-Bus Transceiver
  - ♦ LIN Compliant to Specification Revision 2.1 (Backward Compatible to Versions 2.0 and 1.3) and SAE J2602
  - ♦ Bus Voltage  $\pm 45$  V
  - ♦ Transmission Rate up to 20 kBaud
  - ♦ Integrated Slope Control for Improved EMI Compatibility
- Protection
  - ♦ Thermal Shutdown
  - ♦ Indefinite Short-circuit Protection on Pins LIN and WAKE Towards Supply and Ground
  - ♦ Load Dump Protection (45 V)
  - ♦ Bus Pins Protected against Transients in an Automotive Environment
  - ♦ ESD Protection Level for LIN, INH, WAKE and Vbb up to  $\pm 10$  kV
- Voltage Regulator
  - ♦ Two Device Versions: Output Voltage 3.3 V or 5 V for Loads up to 150 mA
  - ♦ Under-voltage Detector with a Reset Output to the Supplied Microcontroller
  - ♦ Over-current Limitation
  - ♦ INH Output for Auxiliary Purposes (Switching of an External Pull-up or Resistive Divider towards Battery, Control of an External Voltage Regulator etc.)

#### Typical Applications

- Automotive
- Industrial Network

# NCV7425EVB

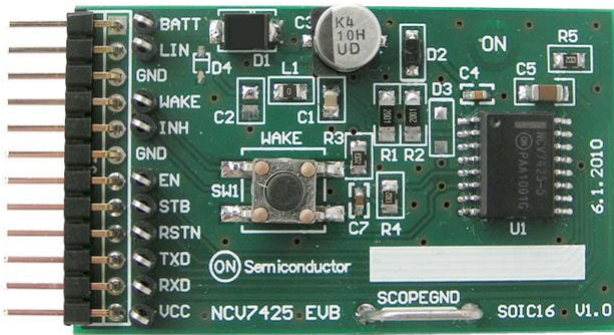
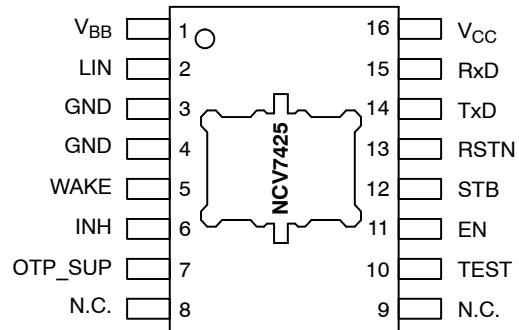

Figure 1. NCV7425EVB

## NCV7425 PIN CONNECTIONS



SOIC-16 LEAD  
WIDE BODY  
EXPOSED PAD  
CASE 751AG

## Getting Started

### Master/Slave Configuration

The NCV7425 evaluation board can be configured as Master or Slave node. Furthermore, Master node LIN bus pull-up resistance ( $R_{LIN}$ ) can be tied to VBB supply line or to INH pin (See the figures below).

The EMC immunity of the Master-node device can be further enhanced by adding a capacitor between the LIN output and ground ( $C_{LIN}$ ). The optimum value of this capacitor is determined by the length and capacitance of the LIN bus, the number and capacitance of Slave devices, the pull-up resistance of all devices (Master and Slave), and the required time constant of the system.

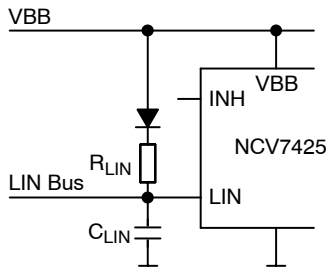

Figure 2. Master with Pull-up to VBB

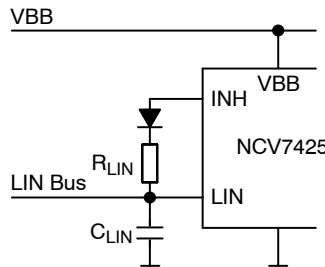

Figure 3. Master with Pull-up to INH

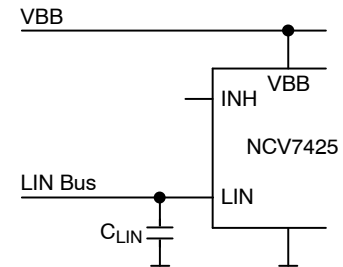

Figure 4. Slave Configuration

### Basic Connection

A simple LIN network configuration is shown in the figure below. One Master and one Slave node is required (Master/Slave Configuration).

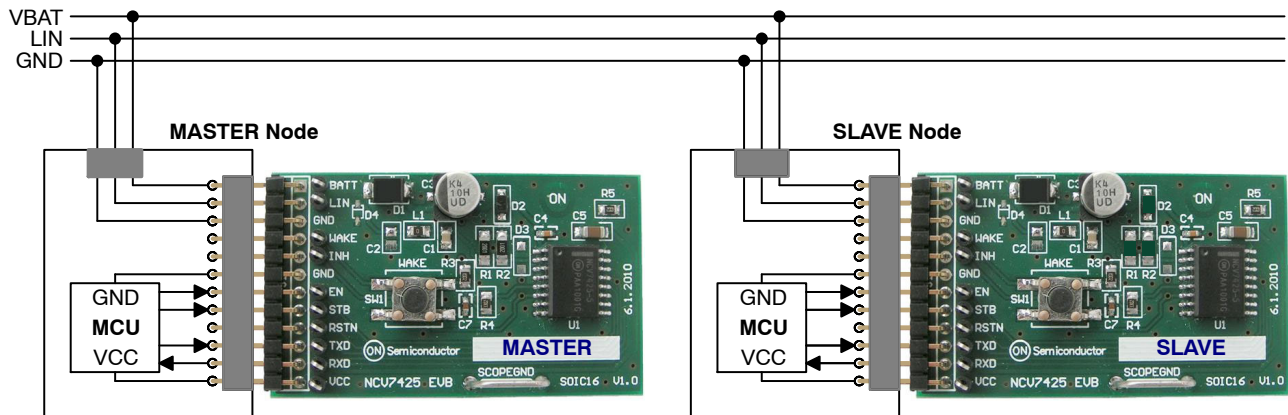

Figure 5. NCV7425 Evaluation Setup Connection

## Functional Description

### Overall Functional Description

NCV7425 is designed as a master or slave node for the LIN communication interface with an integrated 3.3 V or 5 V voltage regulator having a current capability up to 150 mA for supplying any external components (microcontroller, CAN node, etc.).

NCV7425 contains the LIN transmitter, LIN receiver, voltage regulator, power-on-reset (POR) circuits and thermal shutdown (TSD). The LIN transmitter is optimized for the maximum specified transmission speed of 20 kBaud with EMC performance due to reduced slew rate of the LIN output.

The junction temperature is monitored via a thermal shutdown circuit that switches the LIN transmitter and voltage regulator off when temperature exceeds the TSD trigger level.

NCV7425 has four operating states (normal mode, low slope mode, stand-by mode, and sleep mode) that are determined by the input signals EN, WAKE, STB, and TxD.

### Operating States

NCV7425 provides four operating states, two modes for normal operation with communication, one stand-by without communication and one low power mode with very low current consumption - see Figure 6 and Table 1.

**Table 1. MODE SELECTION**

Mode	Vcc	RxD	INH	LIN Transceiver	30 kΩ on LIN	RSTN
Normal – Slope (Note 1)	ON	Low = Dominant State High = Recessive State	High if STB = High during State Transition; Floating Otherwise	Normal Slope	ON	High
Normal – Low Slope (Note 2)	ON	Low = Dominant State High = Recessive State	High if STB = High during State Transition; Floating Otherwise	Low Slope	ON	High
Stand-by (Note 3)	ON	Low after LIN Wakeup, High Otherwise (Note 4)	Floating	OFF	OFF	Controlled by VCC Under-voltage Monitor
Sleep	OFF	Clamped to Vcc (Note 4)	Floating	OFF	OFF	Low

1. The normal slope mode is entered when pin EN goes HIGH while TxD is in HIGH state during EN transition.
2. The low slope mode is entered when pin EN goes HIGH while TxD is in LOW state during EN transition. LIN transmitter gets on only after TxD returns to high after the state transition.
3. The stand-by mode is entered automatically after power-up.
4. In Stand-by and Sleep mode, the High state is achieved by internal pull-up resistor to VCC.

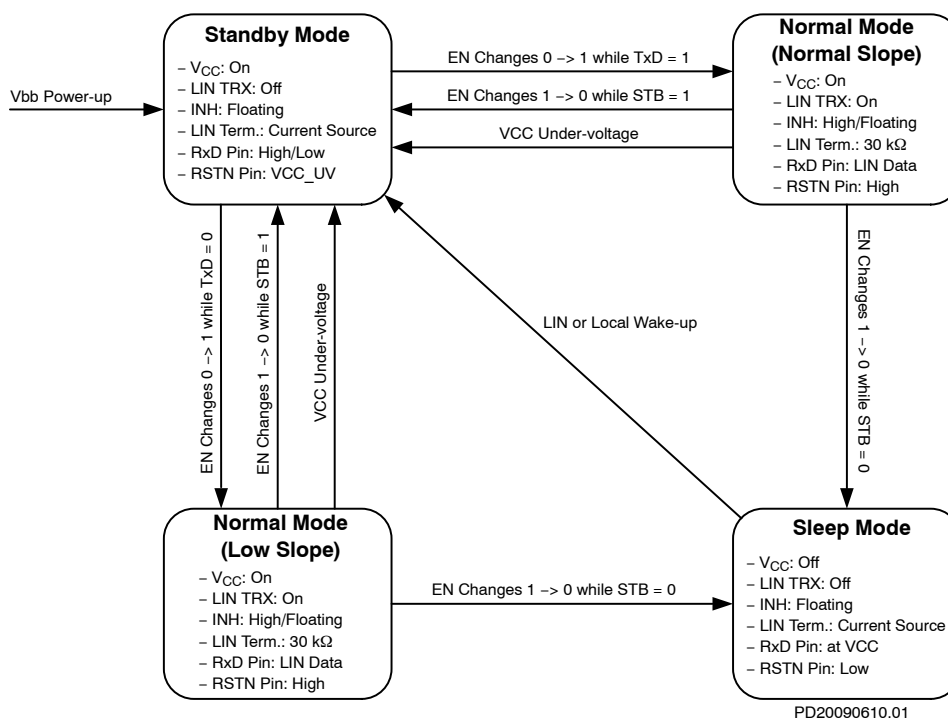

**Figure 6. NCV7425 State Diagram**

PD20090610.01

Additional details of the NCV7425 operation and parameters can be found in the corresponding datasheet [1].

# NCV7425EVB

## Schematic

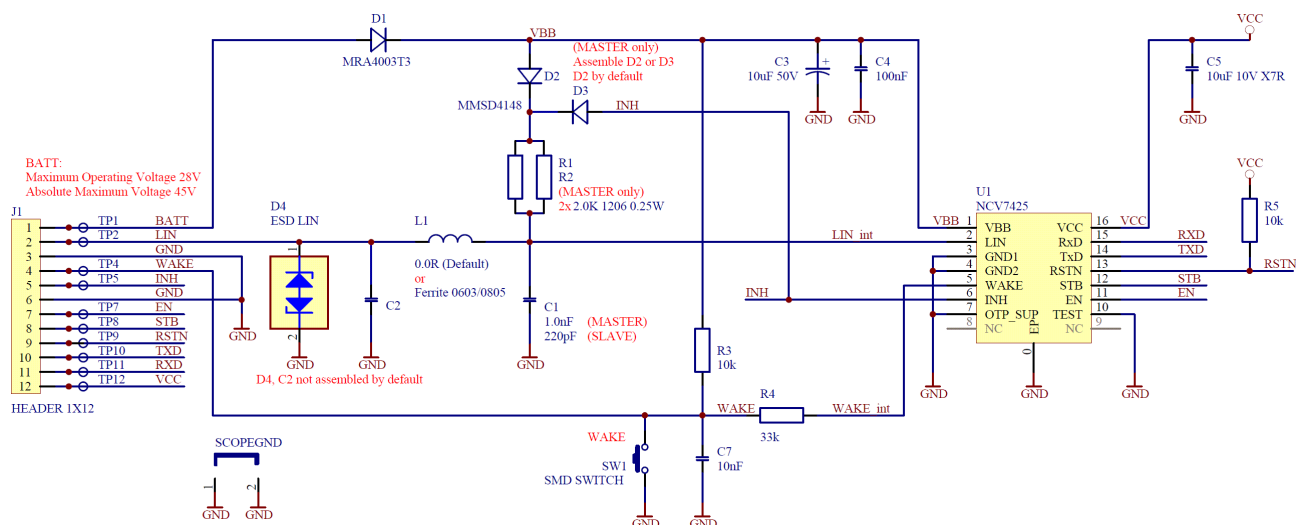

Figure 7. NCV7425 LIN Transceiver with Voltage Regulator and Reset Pin Evaluation Board Schematic

## Bill of Materials

Table 2. NCV7425 Evaluation Board Bill of Materials

Designator	Description	Value	Footprint	Manufacturer	Manufacturer Part Number
C1	Capacitor SMD	1.0 nF	CAP0805	PHYCOMP	2238 580 15623
R1, R2	Resistor SMD	2.0 kΩ 1206 0.25 W	R1206	WELWYN	WCR 1206 2K 2%
R3, R5	Resistor SMD	10 kΩ	R0805	MULTICOMP	MC 0.1 W 0805 1% 10K
C7	Capacitor SMD	10 nF	CAP0603	EPCOS	B37931K5103K60
C5	Capacitor SMD X7R	10 µF 10 V X7R	CAP1206	KEMET	C1206C106K8RAC
C3	Electrolytic Capacitor SMD	10 µF 50 V	6.3 x 6.3 SMD	NICHICON	UUD1H100MCL1GS
R4	Resistor SMD	33 kΩ	R0805	MULTICOMP	MC 0.1 W 0805 1% 33K
C4	Capacitor SMD	100 nF	CAP0603	KEMET	C0603C104K5RAC
C2	Capacitor SMD (Optional)	(Optional)	CAP0805	(Optional)	(Optional)
D1	Diode SMD	MRA4003	SMA	ON Semiconductor	MRA4003T3G
D4	LIN bus ESD protection diode	ESD LIN	SOD323	(Optional)	(Optional)
L1	Resistor SMD (Optional Ferrite)	0R	R0805	MULTICOMP	MC 0.1W 0805 0R
J1	SIL HEADER 12 pins Right Angle	HEADER 1X12	HDR1x12	MOLEX	90121-0772
D2, D3	Switching Diode SMD	MMSD4148	SOD123	ON Semiconductor	MMSD4148T1G
U1	LIN Transceiver with 3.3 V or 5 V Voltage Regulator	NCV7425	SOIC16_WB_EP	ON Semiconductor	3.3 V: NCV7425DW0R2G 5 V: NCV7425DW5R2G
SCOPEGND	SCOPEGND; Wire Bridge	SCOPEGND	SCOPEGND	-	-
SW1	SWITCH SMD SPNO 6 x 6 mm	SMD SWITCH	PB300	TYCO ELECTRONICS	FSM2JSMA
FT1, FT2, FT3, FT4	Rubber feet 12,7 x 12,7 x 5,8	SUPPORT FEET	FEET 12,7 x 12,7	3M	SJ5018BLACK
TP1, TP2, TP4, TP5, TP7, TP8, TP9, TP10, TP11, TP12	Testpin 200 SER. Hole 1.0 Black	TP S200 H1.0 BLACK	TESTPIN2	VERO	20-2137

# NCV7425EVB

## PCB Drawings

### Assembly Drawings

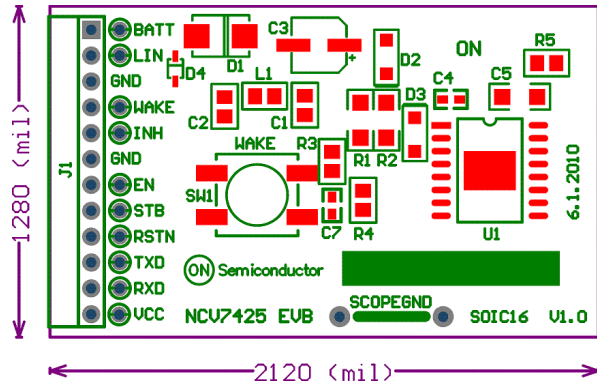

Figure 8. NCV7425EVB PCB Top Assembly Drawing

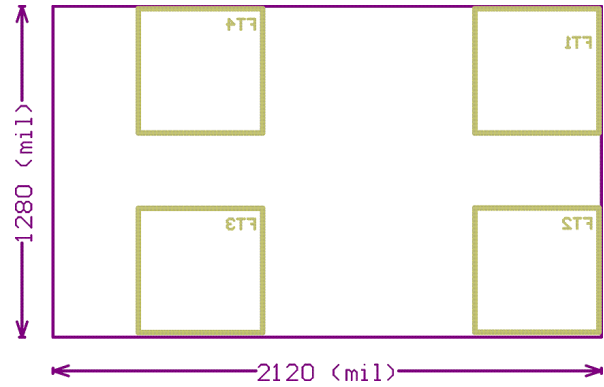

Figure 9. NCV7425EVB PCB Bottom Assembly Drawing

### Composite Drawings

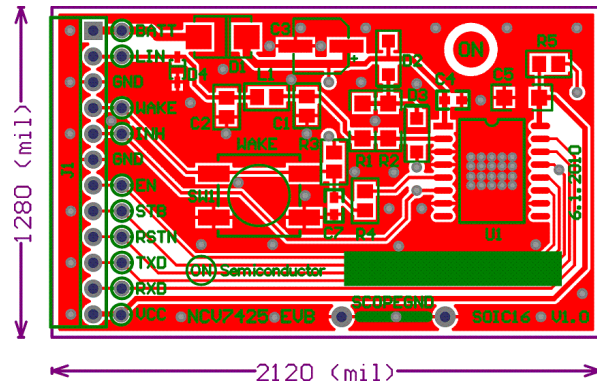

Figure 10. NCV7425EVB PCB Top Composite Drawing

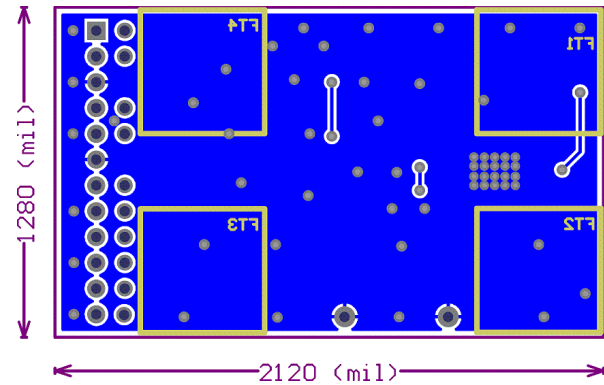

Figure 11. NCV7425EVB PCB Bottom Composite Drawing (Mirrored)

### PCB Preview

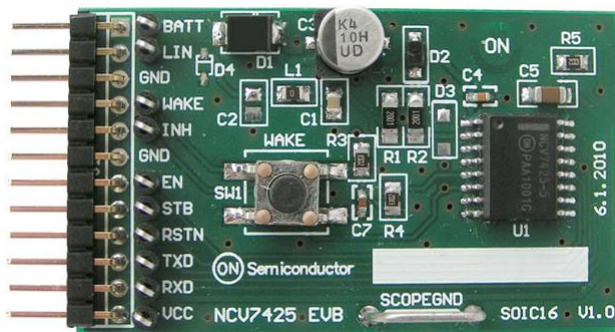

Figure 12. NCV7425EVB PCB Top Side View

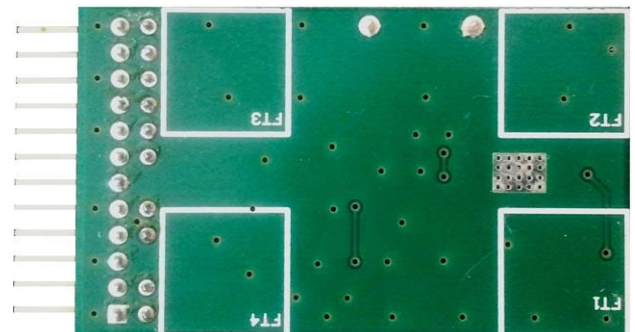

Figure 13. NCV7425EVB PCB Bottom Side View

# NCV7425EVB

## References

- [1] On Semiconductor, NCV7425 Product Preview Revision P0, August 2011.

ON Semiconductor and the ON Semiconductor logo are trademarks of Semiconductor Components Industries, LLC dba ON Semiconductor or its subsidiaries in the United States and/or other countries. ON Semiconductor owns the rights to a number of patents, trademarks, copyrights, trade secrets, and other intellectual property. A listing of ON Semiconductor's product/patent coverage may be accessed at [www.onsemi.com/site/pdf/Patent-Marking.pdf](http://www.onsemi.com/site/pdf/Patent-Marking.pdf). ON Semiconductor is an Equal Opportunity/Affirmative Action Employer. This literature is subject to all applicable copyright laws and is not for resale in any manner.

The evaluation board/kit (research and development board/kit) (hereinafter the "board") is not a finished product and is as such not available for sale to consumers. The board is only intended for research, development, demonstration and evaluation purposes and should as such only be used in laboratory/development areas by persons with an engineering/technical training and familiar with the risks associated with handling electrical/mechanical components, systems and subsystems. This person assumes full responsibility/liability for proper and safe handling. Any other use, resale or redistribution for any other purpose is strictly prohibited.

The board is delivered "AS IS" and without warranty of any kind including, but not limited to, that the board is production-worthy, that the functions contained in the board will meet your requirements, or that the operation of the board will be uninterrupted or error free. ON Semiconductor expressly disclaims all warranties, express, implied or otherwise, including without limitation, warranties of fitness for a particular purpose and non-infringement of intellectual property rights.

ON Semiconductor reserves the right to make changes without further notice to any board.

You are responsible for determining whether the board will be suitable for your intended use or application or will achieve your intended results. Prior to using or distributing any systems that have been evaluated, designed or tested using the board, you agree to test and validate your design to confirm the functionality for your application. Any technical, applications or design information or advice, quality characterization, reliability data or other services provided by ON Semiconductor shall not constitute any representation or warranty by ON Semiconductor, and no additional obligations or liabilities shall arise from ON Semiconductor having provided such information or services.

The boards are not designed, intended, or authorized for use in life support systems, or any FDA Class 3 medical devices or medical devices with a similar or equivalent classification in a foreign jurisdiction, or any devices intended for implantation in the human body. Should you purchase or use the board for any such unintended or unauthorized application, you shall indemnify and hold ON Semiconductor and its officers, employees, subsidiaries, affiliates, and distributors harmless against all claims, costs, damages, and expenses, and reasonable attorney fees arising out of, directly or indirectly, any claim of personal injury or death associated with such unintended or unauthorized use, even if such claim alleges that ON Semiconductor was negligent regarding the design or manufacture of the board.

This evaluation board/kit does not fall within the scope of the European Union directives regarding electromagnetic compatibility, restricted substances (RoHS), recycling (WEEE), FCC, CE or UL, and may not meet the technical requirements of these or other related directives.

**FCC WARNING** – This evaluation board/kit is intended for use for engineering development, demonstration, or evaluation purposes only and is not considered by ON Semiconductor to be a finished end product fit for general consumer use. It may generate, use, or radiate radio frequency energy and has not been tested for compliance with the limits of computing devices pursuant to part 15 of FCC rules, which are designed to provide reasonable protection against radio frequency interference. Operation of this equipment may cause interference with radio communications, in which case the user shall be responsible, at its expense, to take whatever measures may be required to correct this interference.

ON Semiconductor does not convey any license under its patent rights nor the rights of others.

**LIMITATIONS OF LIABILITY:** ON Semiconductor shall not be liable for any special, consequential, incidental, indirect or punitive damages, including, but not limited to the costs of requalification, delay, loss of profits or goodwill, arising out of or in connection with the board, even if ON Semiconductor is advised of the possibility of such damages. In no event shall ON Semiconductor's aggregate liability from any obligation arising out of or in connection with the board, under any theory of liability, exceed the purchase price paid for the board, if any.

For more information and documentation, please visit [www.onsemi.com](http://www.onsemi.com).

---

## PUBLICATION ORDERING INFORMATION

### LITERATURE FULFILLMENT:

Email Requests to: [orderlit@onsemi.com](mailto:orderlit@onsemi.com)

ON Semiconductor Website: [www.onsemi.com](http://www.onsemi.com)

### TECHNICAL SUPPORT

North American Technical Support:

Voice Mail: 1 800-282-9855 Toll Free USA/Canada

Phone: 011 421 33 790 2910

Europe, Middle East and Africa Technical Support:

Phone: 00421 33 790 2910

For additional information, please contact your local Sales Representative