

Hi-Reliability GaAlAs Infrared Emitting Diode

OP223, OP224 (TX, TXV)

OP224 (S)



Features:

- Processed to OPTEK's military screening program, patterned after MIL-PRF-19500
- Miniature hermetically sealed "pill" package
- Twice the power output of GaAs at same drive current
- "S" level screening available
- Mechanically and spectrally matched to OP600 phototransistors

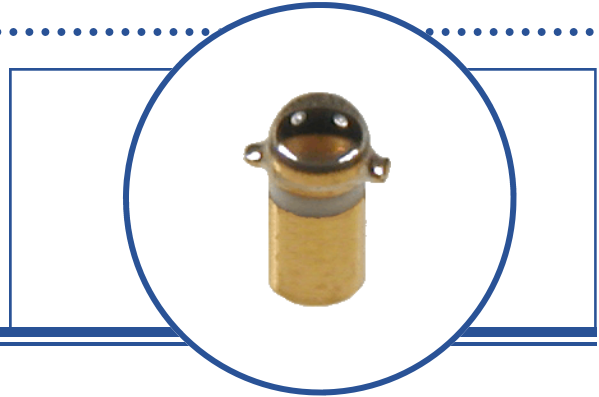

Description:

Each **OP223 (TX, TXV)** and **OP224 (S, TX, TXV)** device is an 890 nm high reliability gallium aluminum arsenide infrared emitting diode that is mounted in a miniature hermetically sealed "pill" type package which can be directly mounted to PCBoards. The gallium aluminum arsenide feature provides twice the radiated output of gallium arsenide at the same forward current.

After electrical testing by manufacturing, devices are processed to OPTEK's 100 percent screening program, which is patterned after MIL-PRF-19500. With a wavelength centered at 890 nm, the *OP223 (TX, TXV)* and *OP224 (S, TX, TXV)*.

TX and TXV devices are processed to OPTEK's military screening program patterned after MIL-PRF-19500. S devices are processed to OPTEK's military screening program patterned after MIL-STD-883.

Please refer to Application Bulletins 208 and 210 for additional design information and reliability (degradation) data.

Contact your local representative or OPTEK for more information.

Applications:

- Non-contact reflective object sensor
- Assembly line automation
- Machine automation
- Machine safety
- End of travel sensor
- Door sensor

Part Number	LED Peak Wavelength	Output Power Minimum	Total Beam Angle	Lead Length
OP223TX	890 nm	1.00 mW/cm ²	24°	N/A
OP223TXV				
OP224S		1.50 mW/cm ²		
OP224TX				
OP224TXV				



Pin #	LED	Sensor
1	Anode	Collector
2	Cathode	Emitter

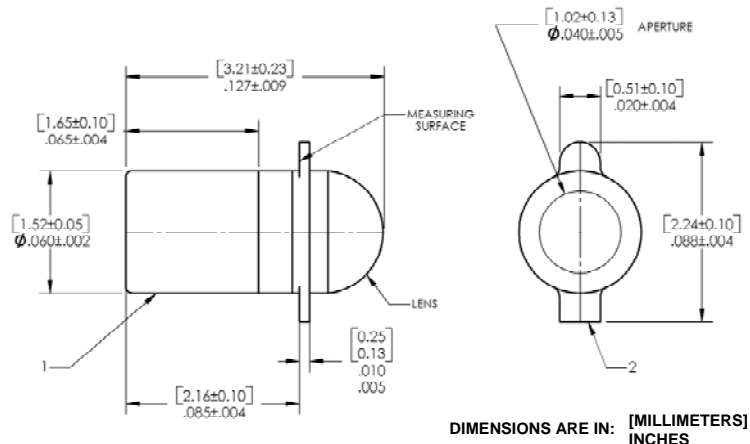

OPTEK reserves the right to make changes at any time in order to improve design and to supply the best product possible.

Hi-Reliability GaAlAs Infrared Emitting Diode
OP223, OP224 (TX, TXV)
OP224 (S)



Absolute Maximum Ratings ($T_A = 25^\circ\text{C}$ unless otherwise noted)

Storage Temperature Range	-65° C to +150° C
Operating Temperature Range	-55° C to +125° C
Lead Soldering Temperature [1/16 inch (1.6 mm) from case for 5 seconds with soldering iron] ⁽¹⁾	260° C
Reverse Voltage	2.0 V
Continuous Forward Current	100 mA
Power Dissipation ⁽²⁾	100 mW

Notes:

1. No clean or low solids. RMA flux is recommended. Duration can be extended to 10 seconds maximum when flow soldering.
2. Derate linearly 1.00 mW/° C above 25° C.

Electrical Characteristics ($T_A = 25^\circ\text{C}$ unless otherwise noted)

SYMBOL	PARAMETER	MIN	TYP	MAX	UNITS	TEST CONDITIONS
--------	-----------	-----	-----	-----	-------	-----------------

Input Diode

SYMBOL	PARAMETER	MIN	TYP	MAX	UNITS	TEST CONDITIONS
E_E (APT)	Radiant Power Output OP223 (TX, TXV) OP224 (S, TX, TXV)	1.00 1.50	- -	- -	mW	$I_F = 50\text{ mA}$ $I_F = 50\text{ mA}$
V_F	Forward Voltage	0.80	-	1.80	V	$I_F = 50\text{ mA}$
I_R	Reverse Current	-	-	100	μA	$V_R = 2.0\text{ V}$
λ_P	Wavelength at Peak Emission	-	890	-	nm	$I_F = 50\text{ mA}$
B	Spectral Bandwidth between Half Power Points	-	80	-	nm	$I_F = 50\text{ mA}$
$\Delta\lambda_P/\Delta T$	Spectral Shift with Temperature	-	0.18	-	nm/°C	$I_F = \text{Constant}$
θ_{HP}	Emission Angle at Half Power Points	-	18	-	Degree	$I_F = 50\text{ mA}$

OPTEK reserves the right to make changes at any time in order to improve design and to supply the best product possible.

Hi-Reliability GaAIAs Infrared Emitting Diode

OP223, OP224 (TX, TXV)
OP224 (S)



OP223 (TX, TXV), OP224 (S, TX, TXV)

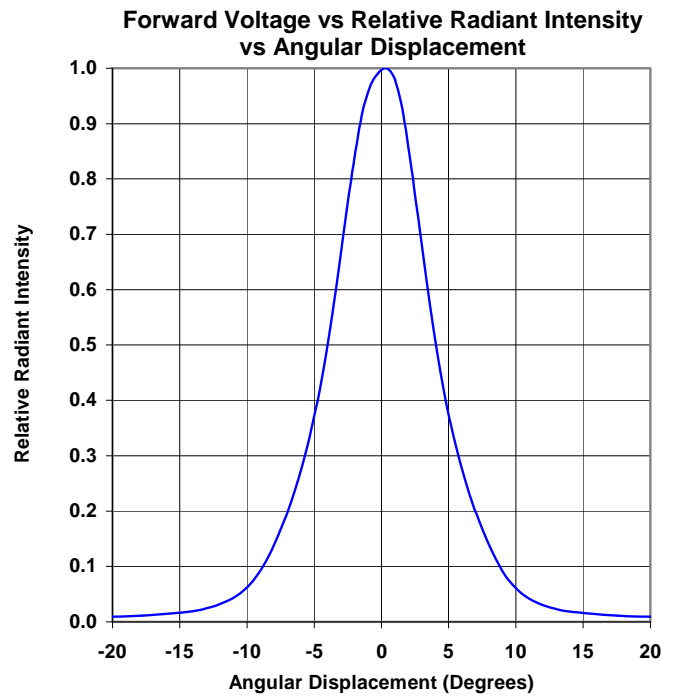
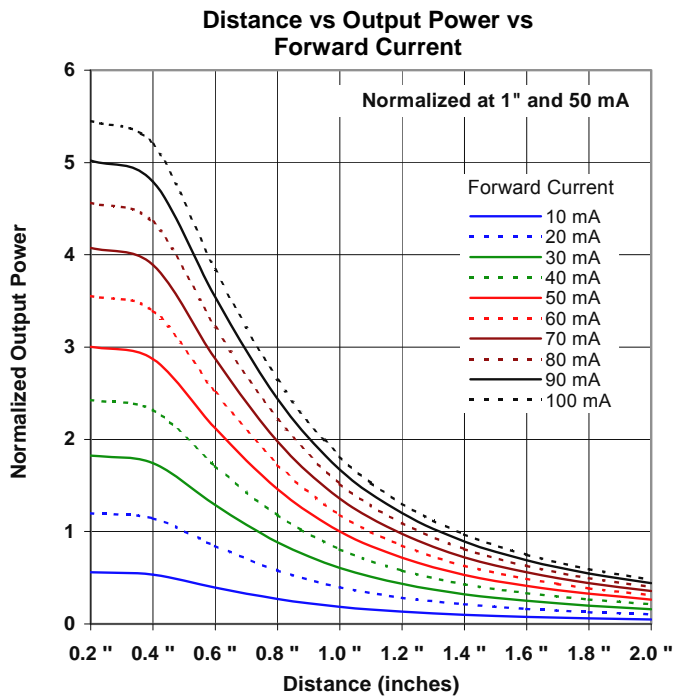
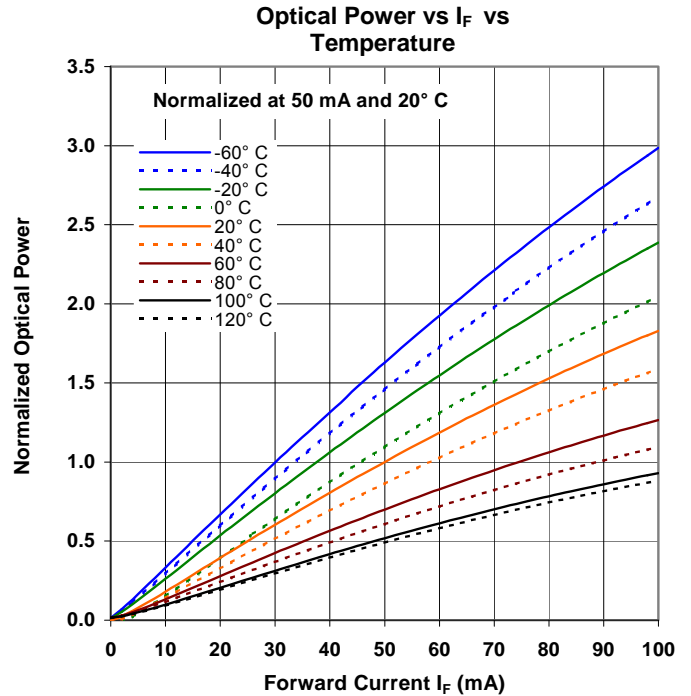
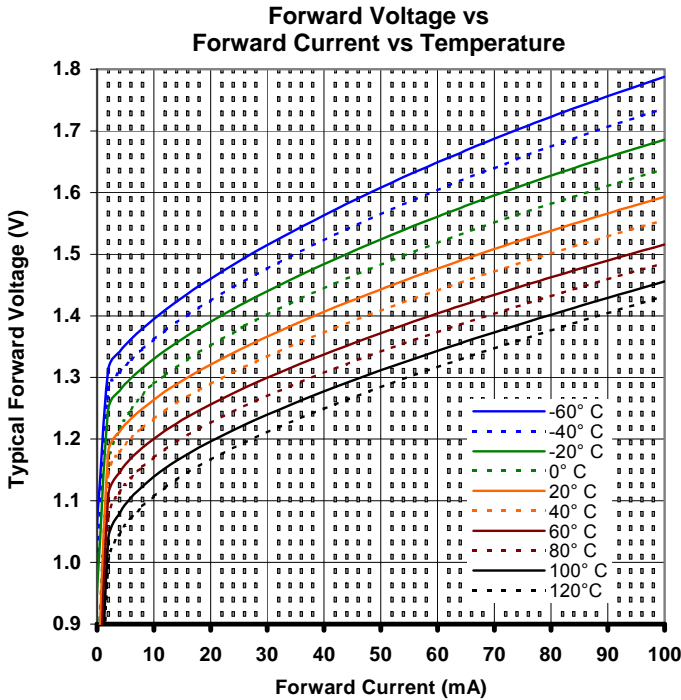

OPTEK reserves the right to make changes at any time in order to improve design and to supply the best product possible.