

Infrared Light Emitting Diode

OPR2800, OPR2800T



Features:

- High-power GaAIAs
- Matches PLCC-2 footprint
- 880 nm wavelength
- Wide beam angle
- Wide operating temperature range (-40° C to +100° C)

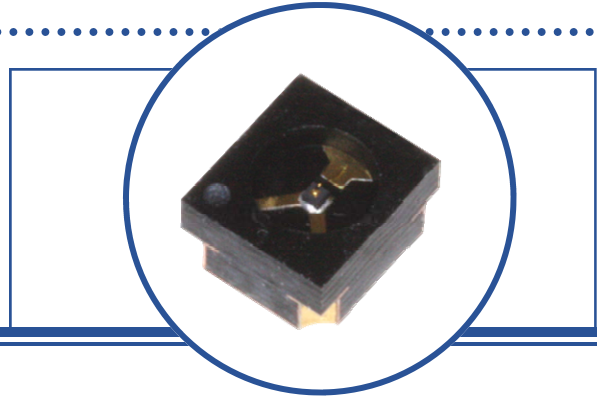

Description:

The **OPR2800** is a GaAIAs infrared LED mounted in a surface mount chip carrier (SMCC) package with a flat lens window that allows a wide beam angle. The SMCC format has a lower height profile than the PLCC-2 package and mounts in the same footprint. The device is suitable for use in single device or array applications. The OPR2800 is spectrally matched to the OPR5500 phototransistor.

Applications:

- Non-contact position sensing
- Machine automation
- Datum detection
- Optical encoding

Ordering Information			
Part Number	LED Peak Wavelength	Total Beam Angle	Packaging
OPR2800	880 nm	100°	Waffle Pack
OPR2800T			Tape & Reel

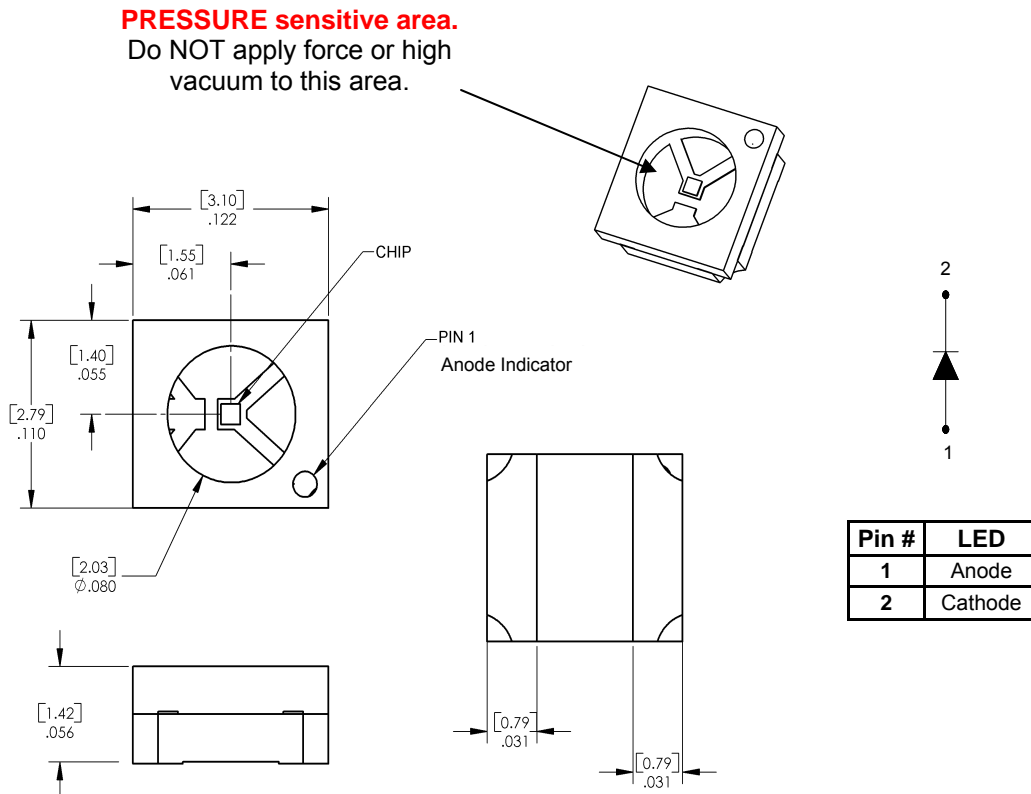

RoHS

OPTEK reserves the right to make changes at any time in order to improve design and to supply the best product possible.

Absolute Maximum Ratings ($T_A = 25^\circ\text{C}$ unless otherwise noted)

Storage Temperature Range	-40° C to +100° C
Operating Temperature Range	-40° C to +100° C
Reverse Voltage	30 V
Continuous Forward Current	50 mA
Solder reflow time within 5° C of peak temperature is 20 to 40 seconds ⁽¹⁾	250° C
Power Dissipation	130 mW ⁽²⁾

Electrical Characteristics ($T_A = 25^\circ\text{C}$ unless otherwise noted)

SYMBOL	PARAMETER	MIN	TYP	MAX	UNITS	TEST CONDITIONS
$E_{E(APT)}$	Apertured Radiant Incidence	0.2	-	-	mW/cm ²	$I_F = 20\text{ mA}$ ⁽³⁾
V_F	Forward Voltage	-	-	1.50	V	$I_F = 50\text{ mA}$
I_R	Reverse Current	-	-	100	μA	$V_R = 2.0\text{ V}$
λ_P	Wavelength at Peak Emission		890	-	nm	$I_F = 10\text{ mA}$
θ_{HP}	Emission Angle at Half Power Points	-	100	-	Degree	$I_F = 20\text{ mA}$
t_r	Output Rise Time, Output Fall Time	-	-	500	ns	$I_{F(PK)} = 100\text{ mA}$, PW = 10 μs , D.C. = 10.0%
t_f	Output Rise Time, Output Fall Time	-	-	500	ps	

Notes:

- Solder time less than 5 seconds at temperature extreme.
- Derate linearly at 1.73 mW/° C above 25° C.
- $E_{E(APT)}$ is a measurement of the apertured radiant incidence upon a sensing area 0.081" (2.06 mm) in diameter, perpendicular to and centered on the mechanical axis of the lens and 0.590" (14.99 mm) from the measurement surface. $E_{E(APT)}$ is not necessarily uniform within the measured area.

OP2800

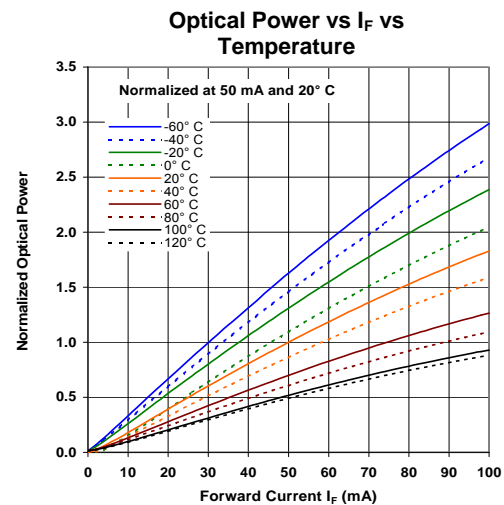
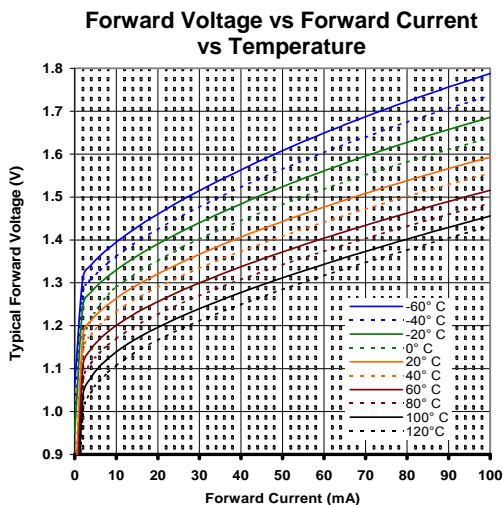

OPTEK reserves the right to make changes at any time in order to improve design and to supply the best product possible.