

発行整理番号 : T1DN-05006
Issue NO. :

発行日 : 2005年2月24日
Date of Issue : February 24, 2005

発行区分 : 新規 変更 更新
Classification: New Change Renewal

To DIGI-KEY

納入仕様書

PRODUCT SPECIFICATION FOR INFORMATION

製品名称 : DNF
Product Description

製品品番 : ELKEA□□□FA
Product Part Number

松下品番 : ELKEA□□□FA
Matsushita Part Number

適用(使用機種等) : 一般電子機器
Applications

上記以外の適用に際しては、事前に弊社担当者までご連絡ください。
For other applications, contact our person signed below.

製造部署 : JAPAN
Manufactured by

お客様ご使用欄 CUSTOMER USE ONLY

この書類を確かに受領しました。
This was certainly received by us.

松下電子部品株式会社
変成器ビジネスユニット
Matsushita Electronic Components Co.,Ltd.
Power Supply and Inductive Products Business Unit

〒571-8506 大阪府 門真市 大字門真1006番地
1006 Kadoma, Kadoma City, Osaka 571-8506, Japan

電話(代表) (06) 6908-3191
Tel (06) 6908-3191 (Representative)

発行部署名 Prepared by コイル技術グループ Inductive Engineering Group Tel (06)6908-1215 Fax (06)6908-7307		
責任者 Approved	検印 Checked	担当者 Designed
<i>S. Minamoto</i>	/	<i>S. Nishimura</i>

1. この製品の使用材料は、「化学物質の審査及び製造等の規制に関する法律」に基づき、すべて既存化学物質として記載されている材料です。

All the materials used in this product are registered material under the Law Concerning the Examination and Regulation of Manufacture, etc. of Chemical Substances.

2. 本製品は、モントリオール議定書で規制されているオゾン層破壊物質(ODC)を製造工程及び購入部品・材料で一切使用していません。

This product has not been manufactured with any ozone depleting chemical controlled under the Montreal Protocol.

3. この製品に使用している全ての材料には、臭素系特定難燃物質「PBBOs、PBBs」を含有していません。

All the materials used in this product contain no brominated materials of PBBOs or PBBs as the flame-retardant.

SPECIFICATIONS

151 - ELKEA - 1 - 10 - E

DNF (Digital Noise Filter)

7 - 1

1 . SCOPE

This specification covers the chip type DNF to be delivered to DIGI-KEY.

2 . PART NUMBER OF PRODUCTS

The part number of the products in this specification shall be ELKEA□□□FA
1 2 3

No .	DIVISION
1	Nominal capacitance value
2	Package form : F --- (Embossed carrier taping)
3	Order of planning from A

3 . TEST CONDITION

The ambient temperature shall be 5°C to 35°C and the relative humidity 35% to 85% unless otherwise specified. When the test result is doubtful, the sample in question shall be tested again at 20±2°C,65±5% RH.

4 . VISUAL,DIMENSIONS AND CONSTRUCTION

As specified in the [151-ELKEA - 2 - 1 - E]

5 . ELECTRICAL AND RELIABILITY CHARACTERISTICS

As specified in the [151-ELKEA - 3 - 1 - E]

6 . TEST METHOD

As specified in the [151-ELKEA - 4 - 1 - E]

7 .PACKAGE

The products shall be packed so as not allow from water absorption and damage.
 The following indications shall be marked on the package:
 1 .Part Number 2 .Quantity 3 . Lot Number 4 .Manufacture's name
 Packaging style and dimension are specified in the [151-ELKEA-5-1-E ,6-1-E]

8 . OPERATING TEMPERATURE RANGE

- 2 0 ~ + 8 5 °C

9 . OTHERS

The customer is requested to store the products at the normal temperature (-5°C to 35°C) and the normal humidity(85% RH max) in the packages we supplied.
 The package shall not be exposed to direct sunlight and harmful gas and care should be taken so as not cause to dew.

10.REVISION

No.	Date	Reg.No.	Description	Page	Check

Notes

Approval 	Check 	Design
--------------	-----------	------------

SPECIFICATIONS

151 - ELKEA - 2 - 1 - E

D N F (Digital Noise Filter)

7 - 2

[VISUAL AND DIMENSIONS]

(unit: mm ...not to scale)

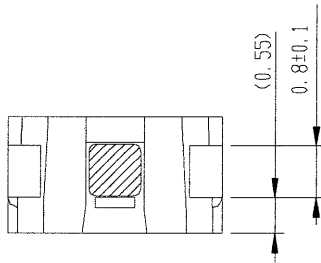
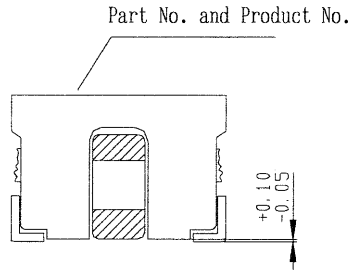
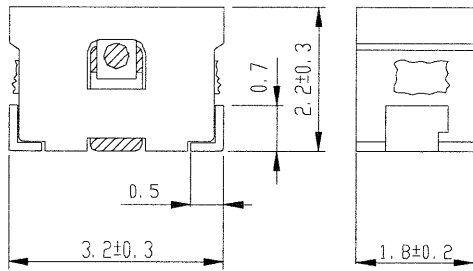

EQUIVALENT CIRCUIT

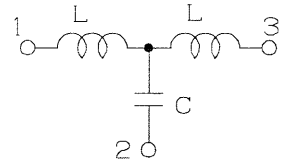

RECOMMENDED LAND PATTERN

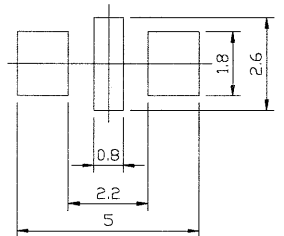

[CONSTRUCTION]

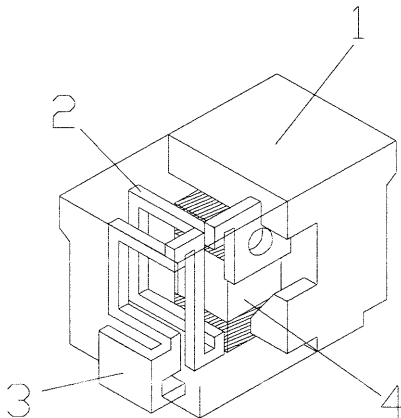

N o	PART NAM	MATERIAL
1	Enclosure	PPS resin mixed with ferrite powder
2	Coil	Copper alloy plate
3	Terminal	Copper alloy plate with SnCu
4	Capacitor	Chip capacitor

Notes

SPECIFICATIONS

151 - ELKEA - 3 - 1 - E

DNF (Digital Noise Filter)

7 - 3

[ELECTRICAL CHARACTERISTICS]

CUSTOMERS PART No.	MATSUSHITA PART No.	L (1-3) ※ (nH)	C (1-2) ※ (pF)	Nominal C (pF)	Rated Current (A max)	Rated Voltage (V max)	Reference	
							Frequency range(MHz)	DCR Ω typ
	ELKEA100FA	14 nH ^{+40%} _{-40%}	10±20%	10	2.0	50	15 d B min.	4 m ohm
	ELKEA220FA		22±20%	22			1200~1500	
	ELKEA470FA		47±20%	47			700~1000	
	ELKEA101FA		100±20%	100			400~1000	
	ELKEA221FA		220±20%	220			250~1000	
	ELKEA471FA		485±20%	470			150~1000	
	ELKEA102FA		1030±30%	1000			70~1000	
	ELKEA222FA		2140±30%	2200			40~1000	
	ELKEA103FA		9700±30%	10000			20~1000	
	ELKEA333FA		32000±30%	33000			4~1000	
					25	2~1000		

※ Conference P7-5

[RELIABILITY CHARACTERISTICS 1/2]

ITEM	SPECIFICATION	TEST METHOD/CONDITION
Temperature characteristic	1. Inductance shall not change more than ±10% 2. Capacitance shall not change more than ±20%	-20~85°C standard : Values at 20°C
Dielectric with-standing voltage	There shall be no evidence of short or open circuit.	250V DC between inductor terminals and enclosure for 1 minute.
Damp heat (steady state) Humidity (steady state)		DNF shall be subjected to 90~95%RH at 60±2°C for 500±8 hours. Measurements shall be made after 48hours stabilization at room temperature.
Change of temperature / (Temperature shock)	1. There shall not be case deformation or change in appearance. 2. Inductance shall not change more than ±10%	DNF shall be subjected 100 times to the following temperature cycle. (1)-40°C 30 minutes (2)85°C 30 minutes. Measurements shall be made after 48hours stabilization at room temperature.
Dry heat / High Temperature	3. Capacitance shall not change more than ±20%	DNF shall be subjected to 85±2°C for 500±8 hours. Measurements shall be made after 48 hours stabilization at room temperature.
Cold / Low Temperature		DNF shall be subjected to -40±2°C for 500±8 hours. Measurements shall be made after 48 hours stabilization at room temperature.
Endurance (Dry heat)	1. There shall not be case deformation or change in appearance. 2. Inductance shall not change more than ±10%	With rated current applied, DNF shall be subjected to 85±2°C for 500±8 hours. Measurements shall be made after 48 hours stabilization at room temperature.
Endurance (Damp heat, steady state)	3. Capacitance shall not change more than ±20%	With rated current applied, DNF shall be subjected to 90~95%RH at 60±2°C for 500±8 hours. Measurements shall be made after 48 hours stabilization at room temperature.

SPECIFICATIONS

151 - ELKEA - 4 - 1 - E

D N F (Digital Noise Filter)

7 - 4

[RELIABILITY CHARACTERISTICS 2/2]

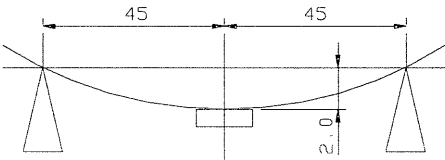
ITEM	SPECIFICATION	TEST METHOD / CONDITION
Solderability	The terminal shall be at least 90% covered with solder.	(Solder : H63A) After fluxing, DNF shall be dipped in a melted solder bath at 230±5°C for 3±0.5 seconds. (Solder : Lead free:Sn-3Ag-0.5Cu) After fluxing, DNF shall be dipped in a melted solder bath at 245±5°C for 3±0.5 seconds.
Resistance to soldering heat	1. There shall not be case deformation or change in appearance.	After a 150±10°C preheat for 1 to 2 minutes, DNF shall be dipped in a melted solder bath at 260±5°C for 10±0.5 seconds.
Vibration (Low frequency)	2. Inductance shall not change more than ±10%	Apply vibration at changing frequencies 10~55Hz per 60 seconds, with an amplitude of 1.5mm to the X, Y and Z directions for 2 hours each. The body is fixed to a PC board by terminals soldering.
Free fall	3. Capacitance shall not change more than ±20%	DNF shall be dropped 10 times from a height of 1m onto a wooden board.
Bend strength	Shall not be disconnection	A load shall be applied to DNF soldered on a PC board and it is bent 2mm then it returns to original position. Repeat 5 times. 

D N F (Digital Noise Filter)

7 - 5

[MEASUREMENT METHOD OF ELECTRICAL CHARACTERISTICS]

1. MEASUREMENT L (Inductance) and C(Capacitance),(with impedance analyzer HP4194A or equivalent)

The equipment shall be set as follows.

The test equipment must have been calibrated beforehand with short and open.

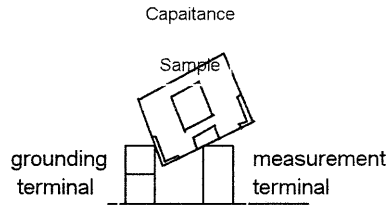
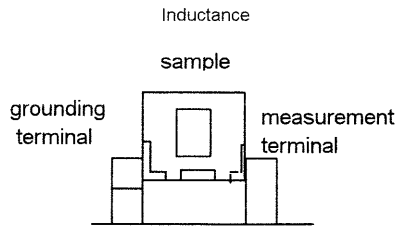
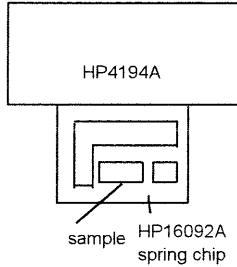

Measurement frequency:
C < 100pF 1MHz
C ≥ 100pF 100KHz

3. MEASUREMENT FREQUENCY ATTENUATION RESPONSE.(with network analyzer HP8753B or equivalent) (Reference)

At first the network analyzer calibrated 0dB with IN-OUT terminal connected, and then frequency attenuation characteristics measured by DNF connected between IN-OUT terminals.

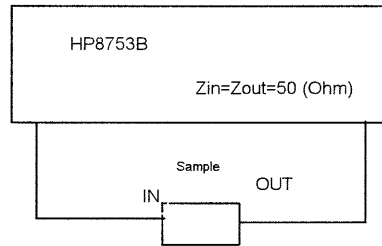

[REFLOW SOLDERING]

Infrared reflow soldering :

This type of reflow soldering at first shall be conducted from 150°C to 180°C preheat for 60 to 120 seconds, successively for up to 30 to 40 seconds in electrode temperature ranges of 230°C or more, and for no more than peak temperature of 260°C.

Reflow soldering is not more than 2 times.

Temperature Profile, Typical

[LEAD FREE REGISTANCE OF REFLOW SOLDERING]

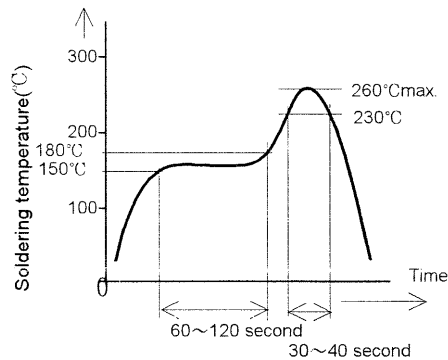

SPECIFICATIONS

151 - ELKEA - 6 - 1 - E

DNF (Digital Noise Filter)

7 - 6

[PACKAGING]

TAPING

Embossed carrier tape(8mm width,4mm pitch) and 178mm diameter reel shall be employed as per JIS C 0806.

1. QUANTITY PER REEL

2,000 pcs. There shall not be more empty pockets than two and those pockets shall not be consecutive.

2. PACKAGING

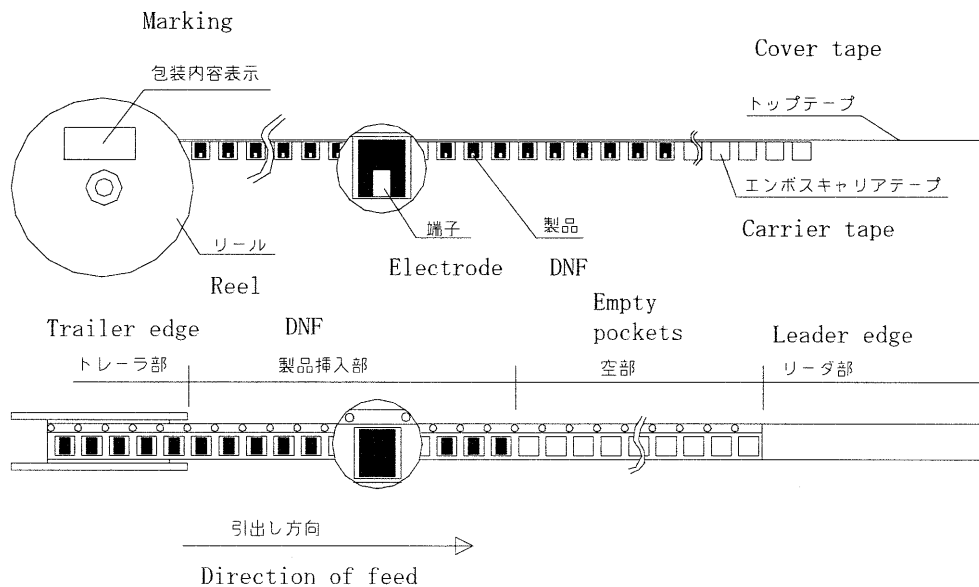

- 2 - 1 As show above, there shall be a leading edge consisting of 25 empty pockets as well as cover tape and a trailing edge consisting of 10 or more empty pockets.
- 2 - 2 DNF shall be packaged with the marking the cover tape and both electrodes shall be vertical to the longitude of the pockets.
- 2 - 3 DNF shall be oriented as specified on the above illustration.

3. MARKING

Customer's Part NO, our Part No, quantity and manufacturer's name shall be marked on the reel.

SPECIFICATIONS

151-ELKEA-7-1-E

D N F (Digital Noise Filter)

7-7

4. COVER TAPE PEEL STRENGTH AND TEST METHOD

The cover tape peel strength shall be 0.098N~0.68N (10g~70g) when measured as shown below.

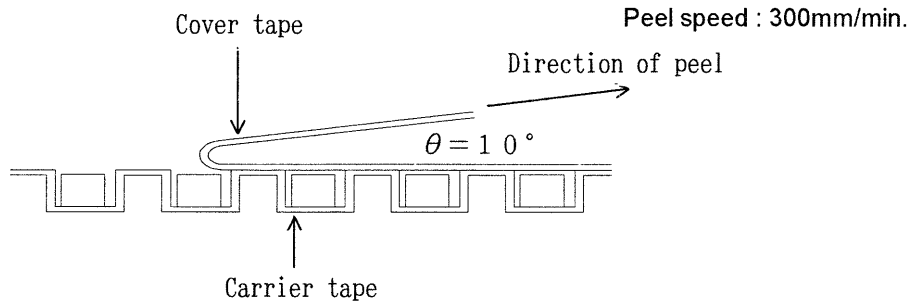

5. CARRIER TAPE DIMENSIONS

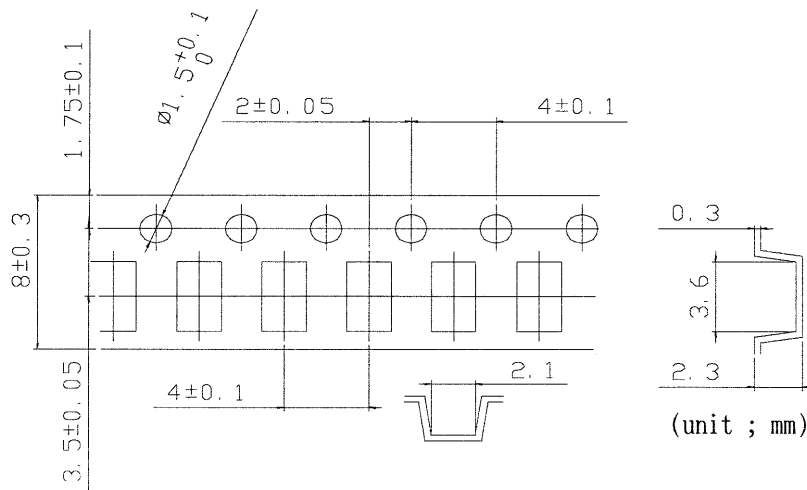

6. REEL DIMENSIONS

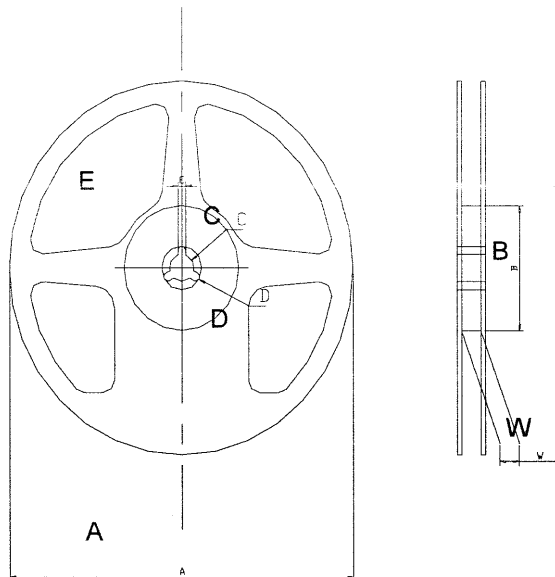

	UNIT
A	$\phi 178 \pm 2.0$
B	$\phi 60 \pm 0.5$
C	13.0 ± 0.5
D	21.0 ± 0.8
E	2.0 ± 0.5
W	9.0 ± 0.3

(unit ; mm)