

## Conductor connectors - QPD CW 4PE2,5 1X6-11 BK - 1403848

Please be informed that the data shown in this PDF Document is generated from our Online Catalog. Please find the complete data in the user's documentation. Our General Terms of Use for Downloads are valid (<http://phoenixcontact.com/download>)



Cable connector panel feed-through, single-sided with QPD nut, black, 4+PE-pos., 1.0 mm<sup>2</sup> ... 2.5 mm<sup>2</sup>/690 V/20 A, for cable diameter of 6 mm ... 11 mm.

### Your advantages

- ✓ Innovative and time saving - QUICKON fast connection for time saving of up to 80 % for on-site connection
- ✓ Convenient: quick and easy assembly without special tools
- ✓ Robust throughout: housing with IP68/IP69K and IK07 protection for a wide range of applications
- ✓ Safer connection thanks to polarization against mismatching and touch-proof protection according to DIN EN 0105
- ✓ Easy and safe - with the cable connector, you can repair or extend cables quickly, in combination with the connector as well as the coupling connection

### Key Commercial Data

Packing unit	1 pc
GTIN	
GTIN	4046356670432

### Technical data

#### General

Type	QPD 5x2,5
Color	black
Locking type	Screw locking
Connection method	QUICKON connection
	IDC connection
Number of positions	5
Note number of positions	4+PE
Wrench size, union nut	27 mm
Tightening torque, union nut	10 Nm
Tightening torque, counter nut	5 Nm
Conductor cross section flexible min.	1 mm <sup>2</sup>

# Conductor connectors - QPD CW 4PE2,5 1X6-11 BK - 1403848

## Technical data

### General

Conductor cross section flexible max.	2.5 mm <sup>2</sup>
Conductor cross section solid min.	1 mm <sup>2</sup>
Conductor cross section solid max.	2.5 mm <sup>2</sup>
Conductor cross section AWG min.	16
Conductor cross section AWG max.	14

### Cabel

Structure of individual litz in acc. with VDE 0295 / smallest wire diameter	VDE 0295 class 1 to 6/min. 0.15 mm
Wire insulation material	PVC/PE/TPE/rubber
Wire diameter including insulation	2 mm ... 3.8 mm
External cable diameter	6 mm ... 11 mm
Position marking	1, 2, 3, N, PE

### Ambient conditions

Degree of protection	IP66
	IP68 (2 m / 24 h)
	IP69K
Ambient temperature (operation)	-40 °C ... 100 °C
Ambient temperature (storage/transport)	-40 °C ... 100 °C
Temperature when conductor connected	-5 °C ... 50 °C

### Electrical characteristics

Nominal current I <sub>N</sub>	20 A
Nominal voltage U <sub>N</sub>	690 V AC
	690 V DC
Rated current	20 A
Rated voltage (III/3)	690 V
Rated voltage (III/2)	1000 V
Rated voltage (II/2)	1250 V
Rated surge voltage (III/3)	6 kV
Rated surge voltage (III/2)	8 kV
Rated surge voltage (II/2)	8 kV

### Mechanical characteristics

QUICKON connectability	max. 10
Insertion/withdrawal cycles	>= 50 (QUICKON connections max. 10)
Category of shock impact	IK07

### Material data

Contact material	Cu
Contact surface material	silver-plated
Contact carrier material	PA
Insulating material	PA

# Conductor connectors - QPD CW 4PE2,5 1X6-11 BK - 1403848

## Technical data

### Material data

Flammability rating according to UL 94	V0
Overvoltage category	III
Degree of pollution	3

### Standards and Regulations

Halogen-free	yes
Flammability rating according to UL 94	V0

### Environmental Product Compliance

China RoHS	Environmentally friendly use period: unlimited = EFUP-e
	No hazardous substances above threshold values

## Drawings

Dimensional drawing

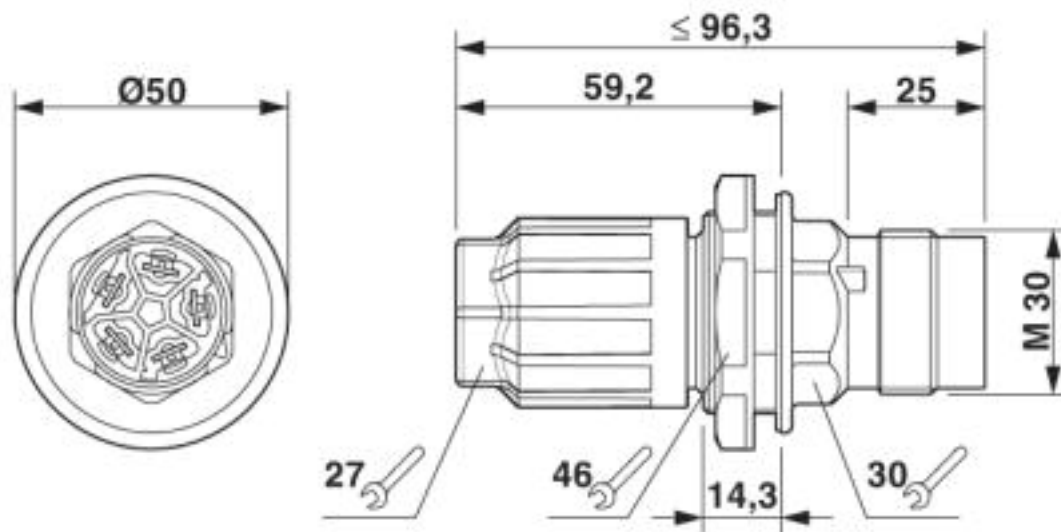

Dimensional drawing of the QPD CW 5x2.5

## Classifications

eCl@ss

eCl@ss 10.0.1	27440605
eCl@ss 4.0	27140800
eCl@ss 4.1	27140800
eCl@ss 5.0	27143400
eCl@ss 5.1	27143400
eCl@ss 6.0	27143400
eCl@ss 7.0	27440605

# Conductor connectors - QPD CW 4PE2,5 1X6-11 BK - 1403848

## Classifications

### eCl@ss

eCl@ss 8.0	27440605
eCl@ss 9.0	27440605

### ETIM

ETIM 3.0	EC000516
ETIM 4.0	EC002635
ETIM 5.0	EC002560
ETIM 6.0	EC002560
ETIM 7.0	EC002560

### UNSPSC

UNSPSC 6.01	30211923
UNSPSC 7.0901	39121522
UNSPSC 11	39121522
UNSPSC 12.01	39121522
UNSPSC 13.2	39121402
UNSPSC 18.0	39121402
UNSPSC 19.0	39121402
UNSPSC 20.0	39121402
UNSPSC 21.0	39121402

## Approvals

### Approvals

#### Approvals

EAC / EAC / DNV GL / UL Listed / cUL Listed / VDE Zeichengenehmigung / cULus Listed

#### Ex Approvals

### Approval details

EAC		RU C- DE.AI30.B.01102
-----	---	--------------------------

EAC		RU C- DE.BL08.B.00511
-----	---	--------------------------

# Conductor connectors - QPD CW 4PE2,5 1X6-11 BK - 1403848

## Approvals

DNV GL		<a href="https://approvalfinder.dnvgl.com/">https://approvalfinder.dnvgl.com/</a>	TAE00003J5
--------	--	---	------------

UL Listed		<a href="http://database.ul.com/cgi-bin/XYV/template/LISEXT/1FRAME/index.htm">http://database.ul.com/cgi-bin/XYV/template/LISEXT/1FRAME/index.htm</a>	FILE E 221474
Nominal voltage UN	600 V		
Nominal current IN	10 A		
mm <sup>2</sup> /AWG/kcmil	16		

cUL Listed		<a href="http://database.ul.com/cgi-bin/XYV/template/LISEXT/1FRAME/index.htm">http://database.ul.com/cgi-bin/XYV/template/LISEXT/1FRAME/index.htm</a>	FILE E 221474
Nominal voltage UN	600 V		
Nominal current IN	10 A		
mm <sup>2</sup> /AWG/kcmil	16		

VDE Zeichengenehmigung		<a href="http://www2.vde.com/de/Institut/Online-Service/VDE-gepruefteProdukte/Seiten/Online-Suche.aspx">http://www2.vde.com/de/Institut/Online-Service/VDE-gepruefteProdukte/Seiten/Online-Suche.aspx</a>	40029149
Nominal voltage UN	690 V		
Nominal current IN	20 A		
mm <sup>2</sup> /AWG/kcmil	1-2.5		

cULus Listed			
--------------	--	--	--

Phoenix Contact 2020 © - all rights reserved  
<http://www.phoenixcontact.com>

PHOENIX CONTACT GmbH & Co. KG  
 Flachsmarktstr. 8  
 32825 Blomberg  
 Germany  
 Tel. +49 5235 300  
 Fax +49 5235 3 41200  
<http://www.phoenixcontact.com>