

Connector - SACC-M12MR-12SOL-PG 9-M SH - 1404412

Please be informed that the data shown in this PDF Document is generated from our Online Catalog. Please find the complete data in the user's documentation. Our General Terms of Use for Downloads are valid (<http://phoenixcontact.com/download>)

Connector, Universal, 12-position, shielded, Plug angled M12, A-coded, Solder connection, knurl material: Zinc die-cast, nickel-plated, cable gland Pg9, external cable diameter 6 mm ... 8 mm



Why buy this product

- Safe use in the field, thanks to a high degree of protection
- Flexible: connectors for on-site assembly
- Save space – with high-pos. connectors
- Reliable signal transmission - 360° shielding in environments with electromagnetic interference

Key Commercial Data

Packing unit	1 STK
GTIN	
GTIN	4046356693851

Technical data

Dimensions

Diameter housing	20.2 mm
Length	41.8 mm
External cable diameter	6 mm ... 8 mm
Stripping length of the sheath	40 mm
Stripping length of the individual wire	4 mm

Ambient conditions

Ambient temperature (operation)	-40 °C ... 85 °C (Plug / socket)
Degree of protection	IP67

General

Rated current at 40°C	1.5 A (up to 40 °C)
Rated voltage	30 V AC

Connector - SACC-M12MR-12SOL-PG 9-M SH - 1404412

Technical data

General

	30 V DC
Number of positions	12
Insulation resistance	> 10 GΩ
Coding	A - standard
Standards/regulations	M12 connector IEC 61076-2-101
Signal type/category	Universal
Status display	No
Overvoltage category	II
Degree of pollution	3
Connection method	Solder connection
Conductor cross section	0.08 mm ² ... 0.25 mm ² (without ferrule)
	0.08 mm ² ... 0.25 mm ² (solid)
Conductor cross section AWG	28 ... 24 (without ferrule)
Insertion/withdrawal cycles	≥ 100
Torque	0.4 Nm (M12 knurl)
	0.8 Nm ... 1 Nm (Pressure screw)
Tightening torque	Screw plug insert with sleeve housing as far it will go
Assembly instructions	The connector pin assignment can be rotated 90° to the cable outlet

Material

Flammability rating according to UL 94	HB
Contact material	CuZn
Contact surface material	Au
Contact carrier material	PA
Material of grip body	Zinc die-cast, nickel-plated
Material, knurls	Zinc die-cast, nickel-plated

Standards and Regulations

Standard designation	M12 connector
Standards/regulations	IEC 61076-2-101
Flammability rating according to UL 94	HB

Environmental Product Compliance

REACH SVHC	Lead 7439-92-1
China RoHS	Environmentally Friendly Use Period = 50
	For details about hazardous substances go to tab "Downloads", Category "Manufacturer's declaration"

Drawings

Connector - SACC-M12MR-12SOL-PG 9-M SH - 1404412

Schematic diagram

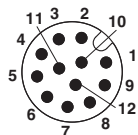

Pin assignment of M12 male connector, 12-pos., A-coded, view of pin side

Dimensional drawing

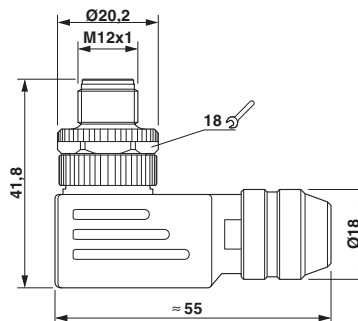

M12 x 1 male plug, angled, shielded

Approvals

Approvals

Approvals

EAC / UL Recognized / cUL Recognized / cULus Recognized

Ex Approvals

Approval details

EAC		EAC-Zulassung
-----	--	---------------

UL Recognized		http://database.ul.com/cgi-bin/XYV/template/LISEXT/1FRAME/index.htm	FILE E 221474
Nominal voltage UN	30 V		
Nominal current IN	1 A		

cUL Recognized		http://database.ul.com/cgi-bin/XYV/template/LISEXT/1FRAME/index.htm	FILE E 221474
Nominal voltage UN	30 V		
Nominal current IN	1 A		

Connector - SACC-M12MR-12SOL-PG 9-M SH - 1404412

Approvals

cULus Recognized



<http://database.ul.com/cgi-bin/XYV/template/LISEXT/1FRAME/index.htm>

Phoenix Contact 2018 © - all rights reserved
<http://www.phoenixcontact.com>

PHOENIX CONTACT GmbH & Co. KG
Flachsmarktstr. 8
32825 Blomberg
Germany
Tel. +49 5235 300
Fax +49 5235 3 41200
<http://www.phoenixcontact.com>