

Socket Outlet - EV-GBM3SE12-3AC32A-0,7M6,0E10 - 1408172

Please be informed that the data shown in this PDF Document is generated from our Online Catalog. Please find the complete data in the user's documentation. Our General Terms of Use for Downloads are valid (<http://phoenixcontact.com/download>)



Socket Outlet, Rear protective cover screw connection, For charging electric vehicles with alternating current (AC), GB/T, GB/T 20234.2-2015, 32 A / 440 V (AC), Single wires, length: 0.7 m, Locking actuator: 12 V, 4-position, Rear panel mounting, Standard

Product Description

Infrastructure Socket Outlet for charging electric vehicles (EV) with alternating current (AC), compatible with GB/T Infrastructure Plugs, for installation at charging stations for E-Mobility (EVSE)

Your advantages

- ✓ Uniform, space-saving installation space of all Phoenix Contact Infrastructure Socket Outlets
- ✓ Silver-plated surface of the power and signal contacts
- ✓ Certified in accordance with IATF 16949:2016 and ISO 9001:2015
- ✓ Material data available in the IMDS (International Material Data System of the automotive industry)
- ✓ Manual emergency release of the locking actuator
- ✓ Integrated interlock during charging



Key Commercial Data

Packing unit	1 pc
GTIN	
GTIN	4046356856034

Technical data

Product definition

Type	Rear protective cover screw connection
Application	For charging electric vehicles with alternating current (AC)
Design	Standard
Standards/regulations	GB/T 20234.2-2015
Charging standard	GB/T
Charging mode	Mode 3, Case B
Note on the connection method	Crimp connection, cannot be disconnected

Socket Outlet - EV-GBM3SE12-3AC32A-0,7M6,0E10 - 1408172

Technical data

Dimensions

Height	96 mm
Width	75 mm
Depth	76.2 mm
Bore dimensions	60 mm x 60 mm
Conductor length	0.7 m (AC cables)
	0.5 m (Locking actuator cables)
Cable structure	5x 6.0 mm ² + 2x 0.5 mm ²
Type of conductor	Single wires

Ambient conditions

Ambient temperature (operation)	-30 °C ... 50 °C
Ambient temperature (storage/transport)	-40 °C ... 80 °C
Max. altitude	5000 m (above sea level)
Degree of protection	IP55 (plugged in)
	IP55 (with protective cover, see accessories)

Electrical properties

Maximum charging power	14 kW
Type of charging current	AC 3-phase
Number of phases	3
Number of power contacts	5 (L1, L2, L3, N, PE)
Rated current of power contacts	32 A
Rated voltage for power contacts	440 V AC
Number of signal contacts	2 (CP, CC)
Rated current for signal contacts	2 A
Rated voltage for signal contacts	30 V AC
Type of signal transmission	Pulse width modulation
Note on the connection method	Crimp connection, cannot be disconnected

Mechanical properties

Insertion/withdrawal cycles	> 10000
Insertion force	< 100 N
Withdrawal force	< 100 N

Mounting

Possible mounting positions	Rear panel mounting
Restrictions to mounting position	Only 0 to 90 degree frontal inclination possible, see figure
Mounting position of the locking actuator	Top center
Required installation depth	< 5 mm (Rear panel mounting)
Max. wall thickness	> 57 mm (Rear panel mounting)
Mounting hole diameter	7.00 mm (ø)

Design

Socket Outlet - EV-GBM3SE12-3AC32A-0,7M6,0E10 - 1408172

Technical data

Design

Design line	Standard
Housing color	black
Customer variations	On request

Material

Material	Plastic
Material surface of contacts	Ag

Locking

Locking type	Locking in the inserted state with a locking mechanism
--------------	--

Locking actuator

Number of positions of theconnectors	4
Operating voltage	12 V (Typical power supply at the motor)
Possible power supply range at the motor	9 V ... 16 V
Maximum voltage for locking detection	30 V
Typical motor current for locking	0.2 A
Reverse current of the motor	max. 1 A
Max. dwell time with reverse current	1000 ms
Recommended adaptation time	600 ms
Pause time after entry or exit path	3 s
Service life insertion cycles	> 10000 load cycles
Ambient temperature (operation)	-30 °C ... 50 °C
Cable length	0.5 m
Cable structure	4 x 0.5 mm ²
Lock recognition	available
Mechanical emergency release	available

Environmental Product Compliance

China RoHS	Environmentally Friendly Use Period = 10;
	For details about hazardous substances go to tab "Downloads", Category "Manufacturer's declaration"

Drawings

Socket Outlet - EV-GBM3SE12-3AC32A-0,7M6,0E10 - 1408172

Schematic diagram

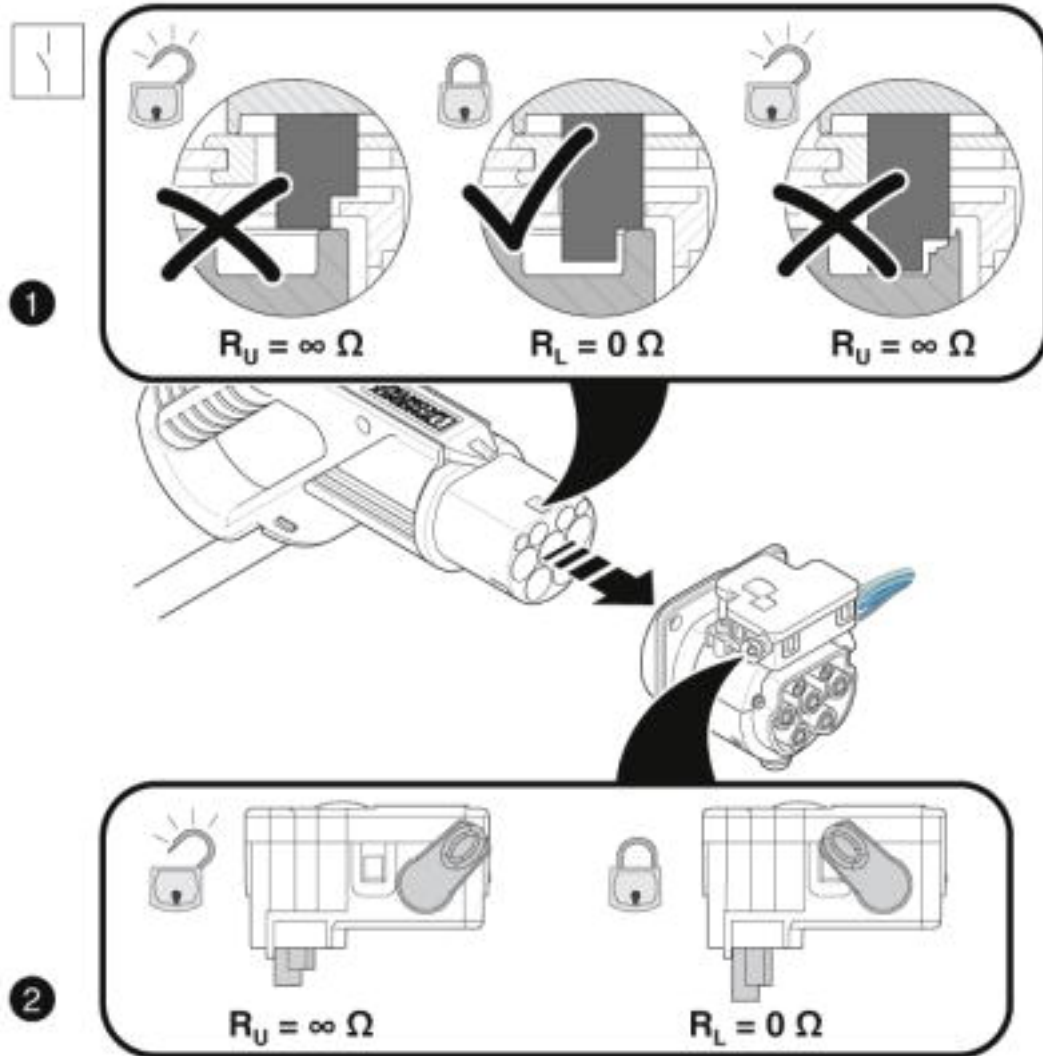

Detection of the Infrastructure Plug

Socket Outlet - EV-GBM3SE12-3AC32A-0,7M6,0E10 - 1408172

Diagram

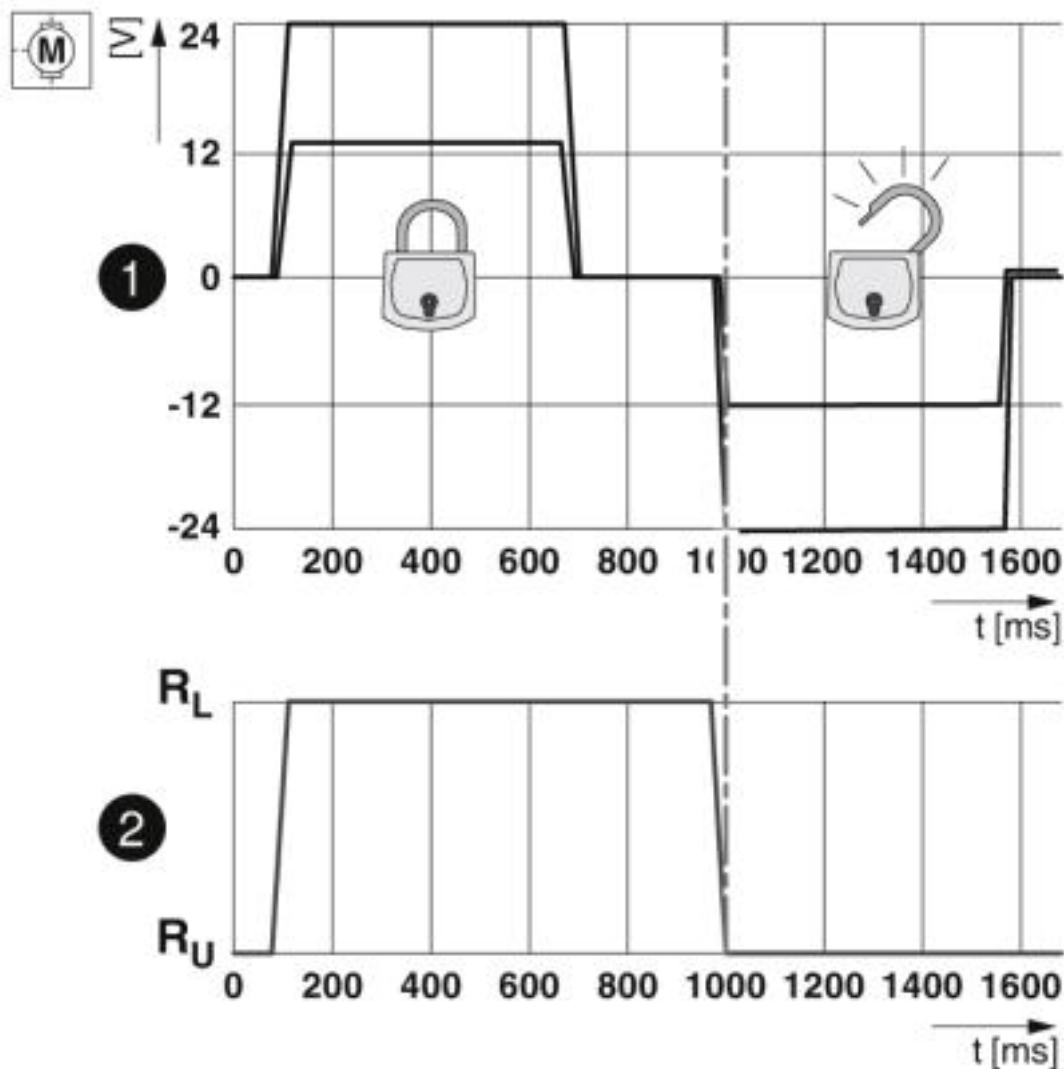

Locking states of the locking actuator

Socket Outlet - EV-GBM3SE12-3AC32A-0,7M6,0E10 - 1408172

Connection diagram

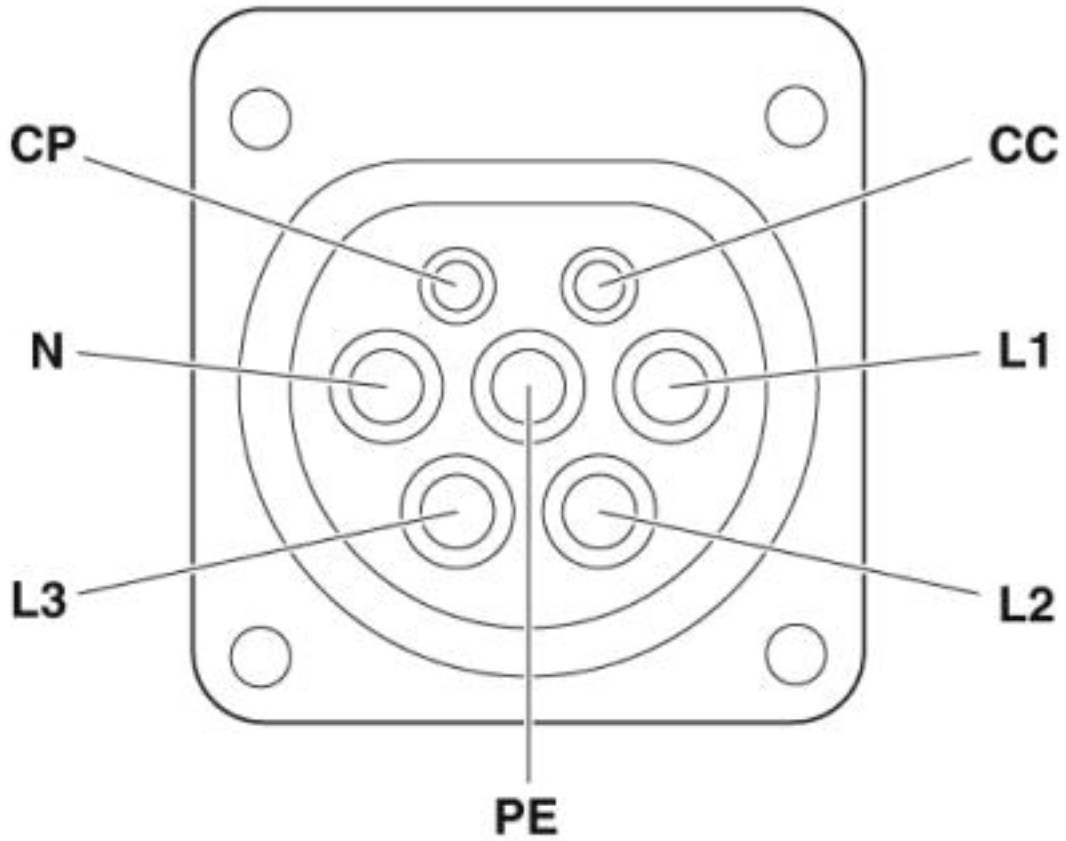

Pin assignment of Infrastructure Socket Outlet

Socket Outlet - EV-GBM3SE12-3AC32A-0,7M6,0E10 - 1408172

Block diagram

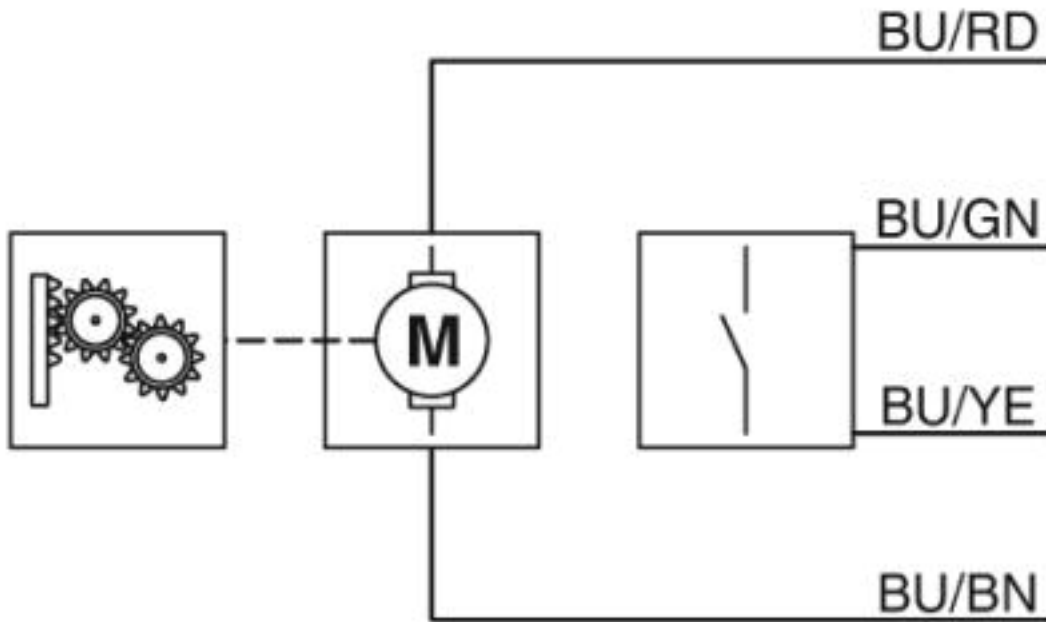

Block diagram of the locking actuator

Socket Outlet - EV-GBM3SE12-3AC32A-0,7M6,0E10 - 1408172

Dimensional drawing

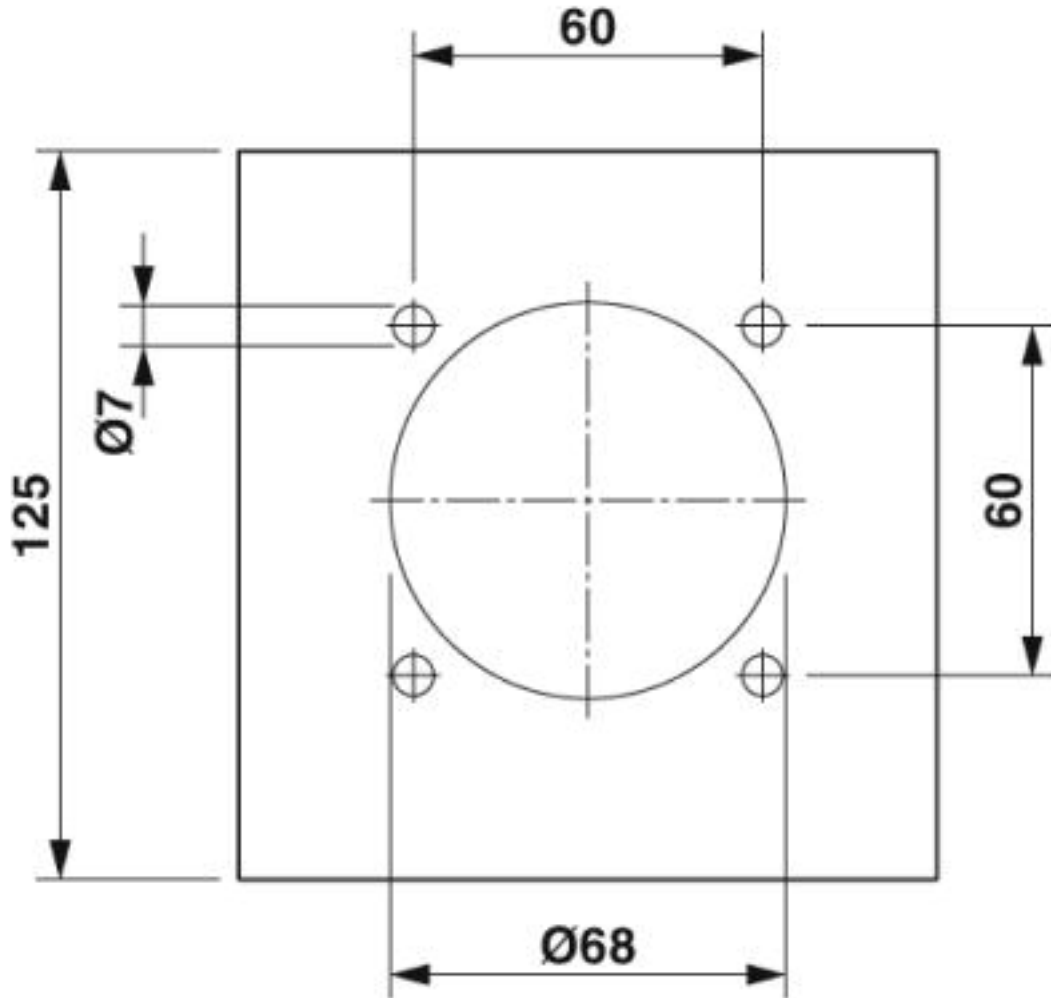

Hole image

Socket Outlet - EV-GBM3SE12-3AC32A-0,7M6,0E10 - 1408172

Dimensional drawing

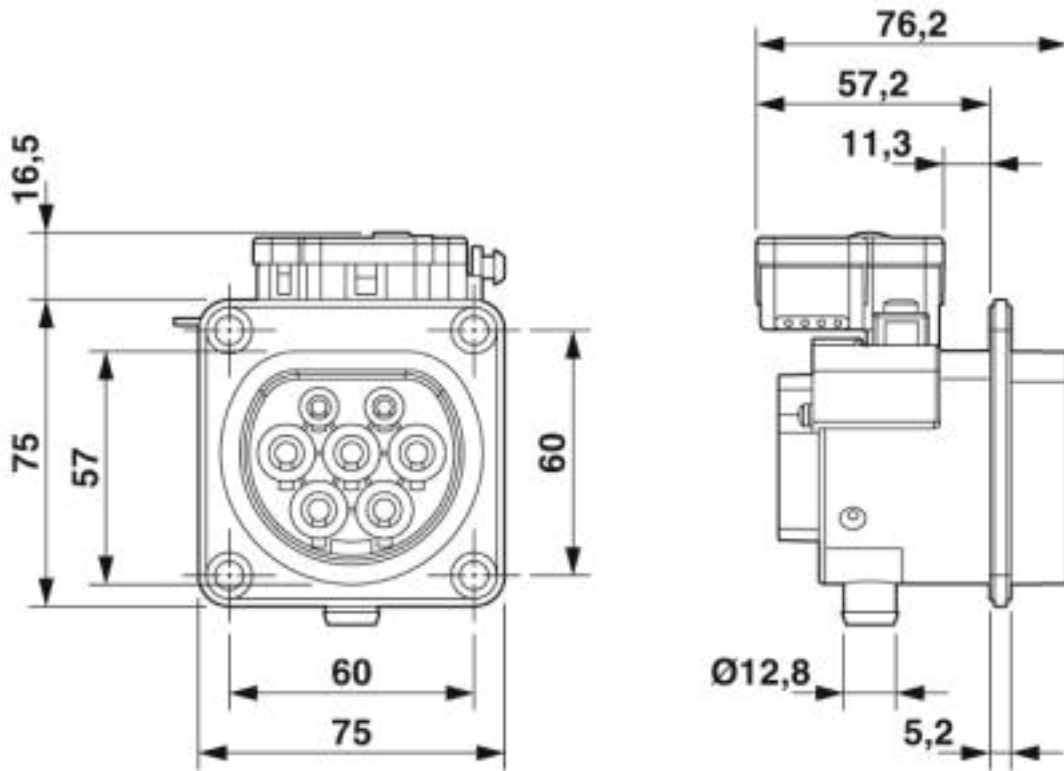

Dimensional drawing

Socket Outlet - EV-GBM3SE12-3AC32A-0,7M6,0E10 - 1408172

Schematic diagram

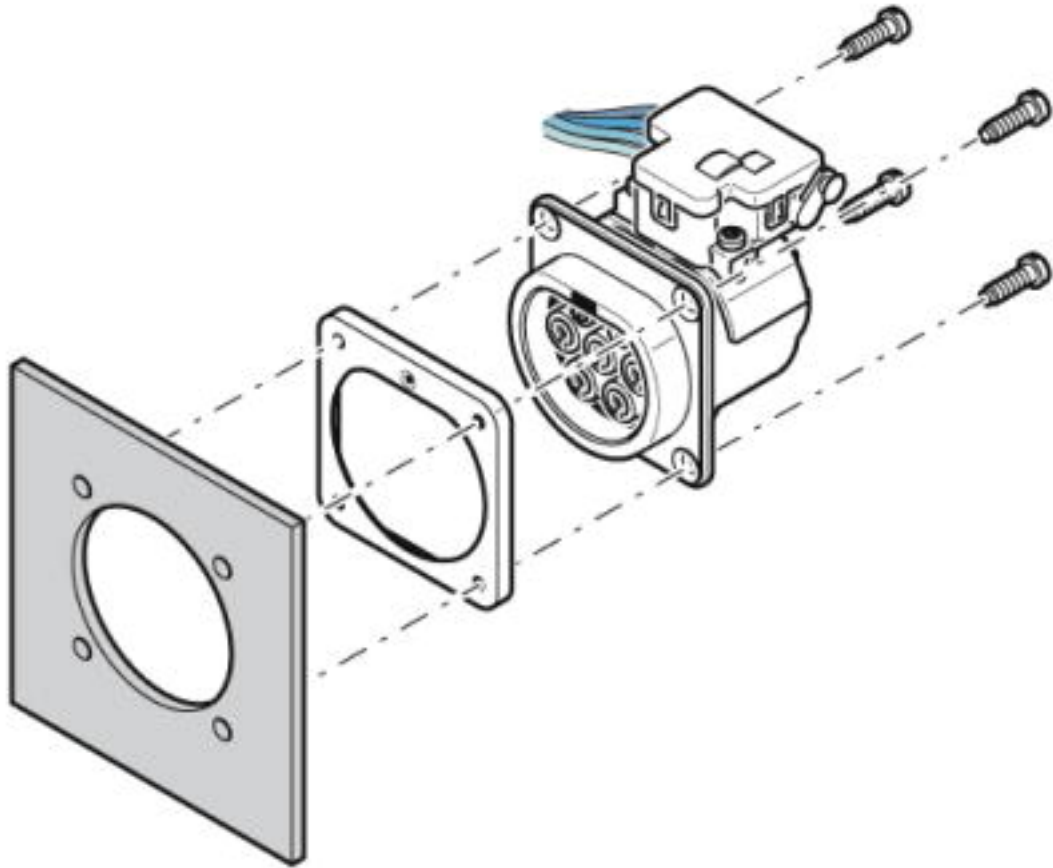

Rear mounting with locking actuator

Socket Outlet - EV-GBM3SE12-3AC32A-0,7M6,0E10 - 1408172

Schematic diagram

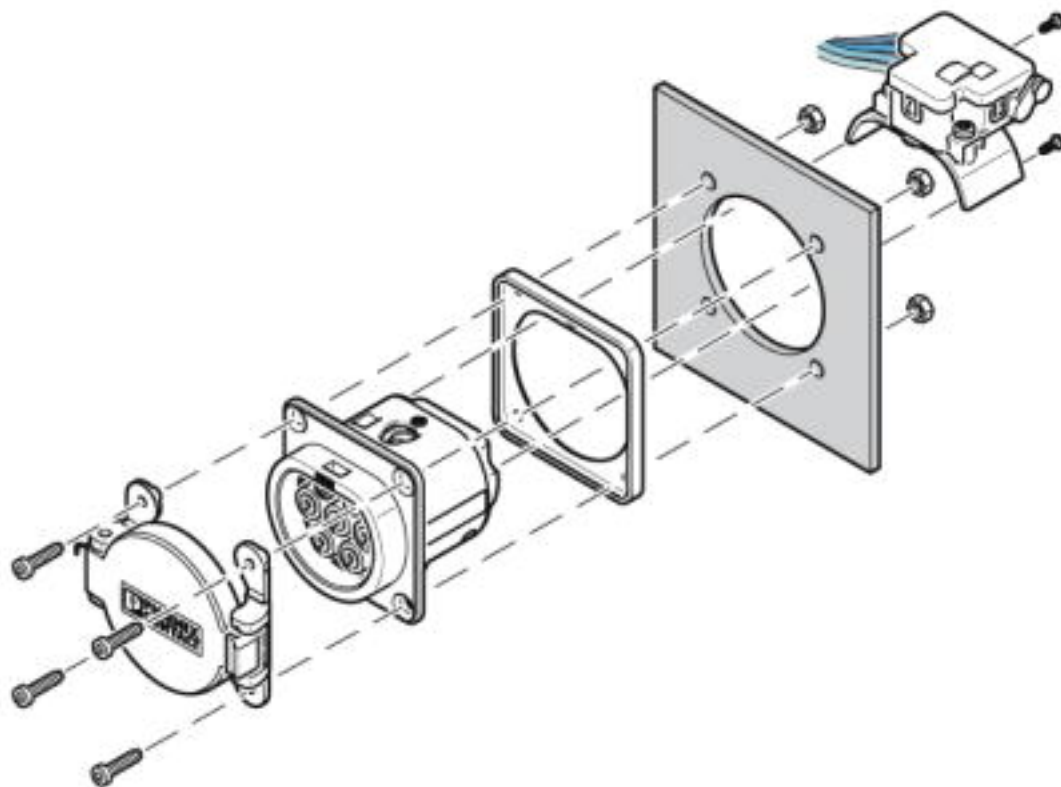

Front mounting with rear protective cover screw connection

Front mounting is only possible when the locking actuator is removed. The screw connection for a protective cover from the accessories range (EV-GBSC...) only supports rear mounting.

Socket Outlet - EV-GBM3SE12-3AC32A-0,7M6,0E10 - 1408172

Schematic diagram

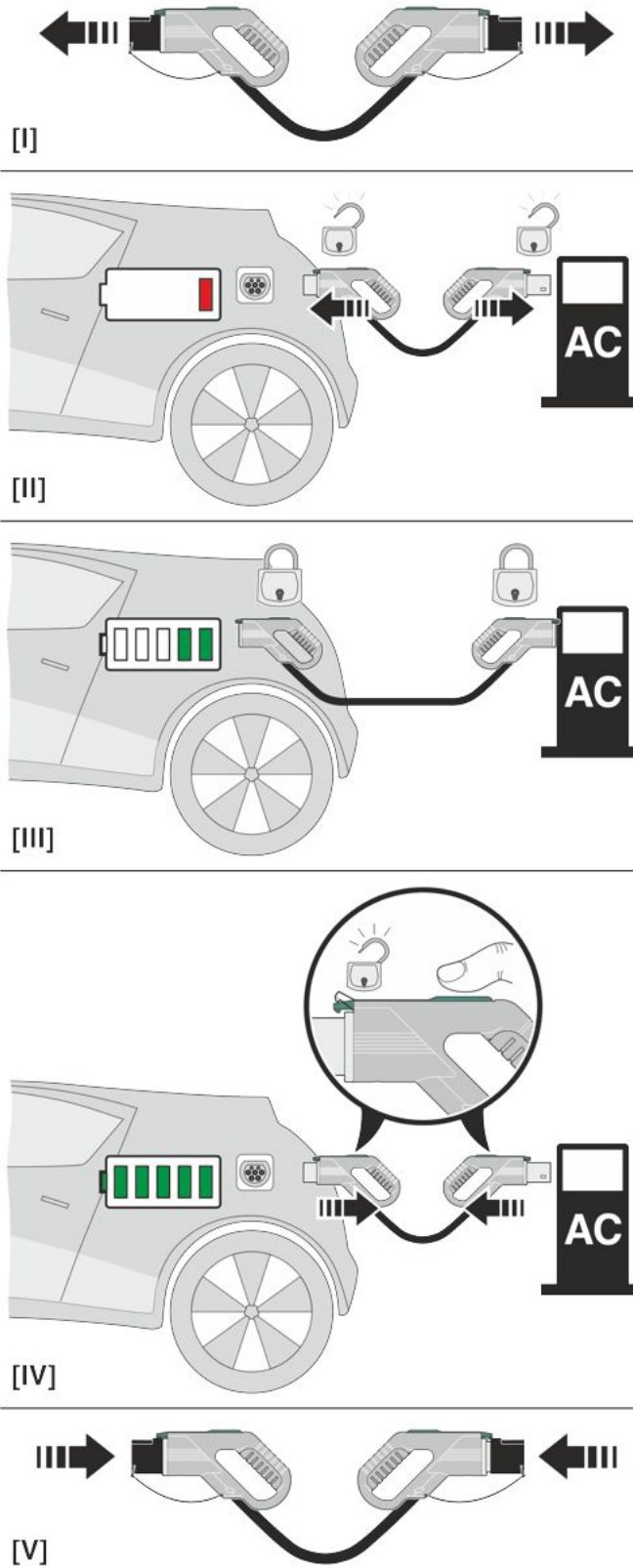

Socket Outlet - EV-GBM3SE12-3AC32A-0,7M6,0E10 - 1408172

Schematic diagram

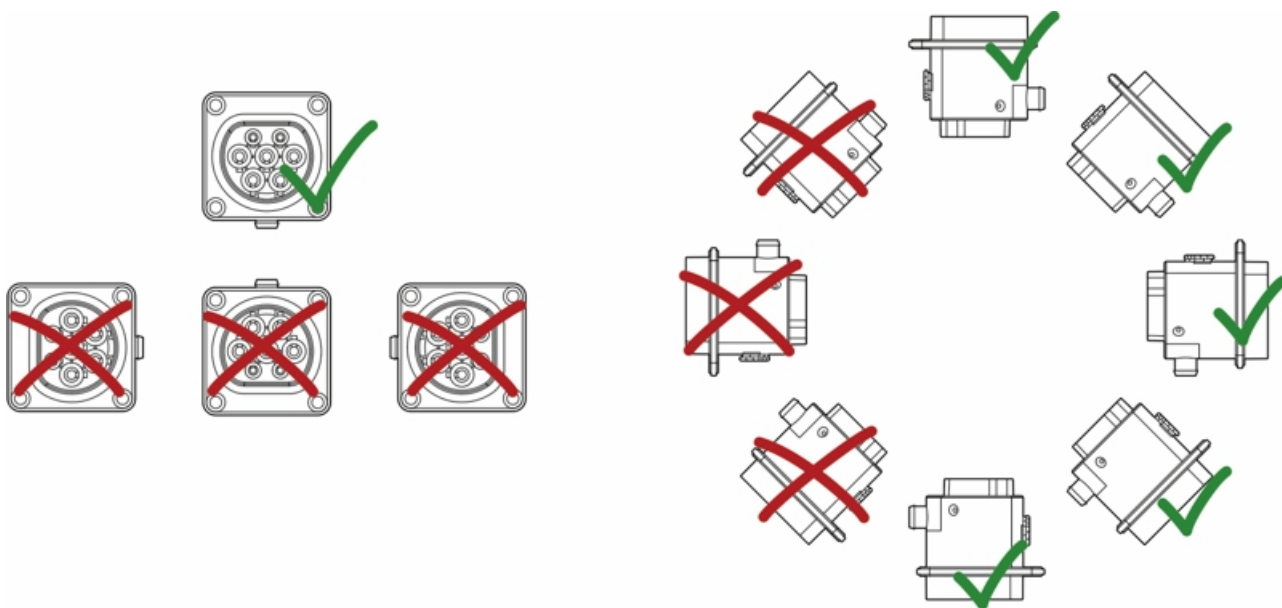

Installation positions

Classifications

eCl@ss

eCl@ss 4.0	272607xx
eCl@ss 4.1	27260701
eCl@ss 5.0	27260701
eCl@ss 5.1	27143400
eCl@ss 6.0	27143400
eCl@ss 7.0	27449001
eCl@ss 8.0	27449001
eCl@ss 9.0	27144706

ETIM

ETIM 3.0	EC002061
----------	----------

Socket Outlet - EV-GBM3SE12-3AC32A-0,7M6,0E10 - 1408172

Classifications

ETIM

ETIM 4.0	EC002061
ETIM 5.0	EC001321
ETIM 6.0	EC002898

UNSPSC

UNSPSC 6.01	30211923
UNSPSC 7.0901	39121522
UNSPSC 11	39121522
UNSPSC 12.01	39121522
UNSPSC 13.2	39121522
UNSPSC 19.0	39121522

Accessories

Accessories

AC charging controller

AC charging controller - EV-CC-AC1-M3-CBC-SER-HS - 1622452



The EV-CC-AC1-M3-CBC-SER-HS charging controller with housing for DIN rail mounting is used for charging electric vehicles at 3-phase AC networks according to IEC 61851-1, Mode 3. All charging functions, comprehensive configuration settings as well as a locking controller are already integrated.

AC charging controller - EV-CC-AC1-M3-CBC-SER-PCB - 1622453



The EV-CC-AC1-M3-CBC-SER-PCB charging controller as PCB is used for charging electric vehicles at 3-phase AC networks according to IEC 61851-1, Mode 3. All charging functions, comprehensive configuration settings as well as a locking controller are already integrated.

AC charging controller - EV-CC-AC1-M3-CBC-SER-PCB-XC-25 - 1627743



The EV-CC-AC1-M3-CBC-SER-PCB charging controller as PCB is used for charging electric vehicles at 3-phase AC networks according to IEC 61851-1, Mode 3. All charging functions, comprehensive configuration settings as well as a locking controller are already integrated.

Socket Outlet - EV-GBM3SE12-3AC32A-0,7M6,0E10 - 1408172

Accessories

AC charging controller - EV-CC-AC1-M3-CBC-SER-PCB-MSTB - 1627353



The EV-CC-AC1-M3-CBC-SER-PCB-MSTB charging controller as a PCB for charging electric vehicles according to IEC 61851-1, Mode 3, Case B (Socket Outlet) or C (Vehicle Connector). Connection via PCB connector on header.

Locking actuator

Locking - EV-T2M3S-E-LOCK12V - 1624129



Locking, For attaching to infrastructure charging sockets, Type 2, GB/T, IEC 61851-1, length: 0.5 m, Locking actuator: 12 V, 4-position, Can be positioned flexibly, Generation 1

Locking - EV-T2M3S-E-LOCK24V - 1622317



Locking, For attaching to infrastructure charging sockets, Type 2, GB/T, IEC 61851-1, length: 0.5 m, Locking actuator: 24 V, 4-position, Can be positioned flexibly, Generation 1

Protective cover for Socket Outlet

Protective covers - EV-GBSCO - 1623415



Protective covers, Self-opening, Rear protective cover screw connection, For attaching to infrastructure charging sockets, GB/T, Type 2, GB/T 20234.2, IEC 62196-2, Front mounting, Generation 1, Adhered PHOENIX CONTACT sticker

Protective covers - EV-GBSC - 1623416



Protective covers, Self-closing, Rear protective cover screw connection, For attaching to infrastructure charging sockets, GB/T, Type 2, GB/T 20234.2, IEC 62196-2, Front mounting, Generation 1, Adhered PHOENIX CONTACT sticker

Socket Outlet - EV-GBM3SE12-3AC32A-0,7M6,0E10 - 1408172

Accessories

Protective covers - EV-GBSC-D6,5MM - 1623888



Protective covers, Self-closing, Rear protective cover screw connection, For attaching to infrastructure charging sockets, GB/T, Type 2, GB/T 20234.2, IEC 62196-2, Front mounting, Generation 1, Adhered PHOENIX CONTACT sticker

Seal

Seal - EV-T2M3S-DRAINAGE-GASKET - 1621668

Seal, For the discharge nozzle below the infrastructure charging socket if there is no drainage tube present, Type 2, IEC 62196-2, Generation 1

Seal - EV-T2M3S-E-LOCK-GASKET - 1621465

Seal, For the mounting surface of the locking actuator above the infrastructure charging socket when there is no locking actuator present, Type 2, IEC 62196-2, Generation 1

Phoenix Contact 2020 © - all rights reserved
<http://www.phoenixcontact.com>

PHOENIX CONTACT GmbH & Co. KG
Flachsmarktstr. 8
32825 Blomberg
Germany
Tel. +49 5235 300
Fax +49 5235 3 41200
<http://www.phoenixcontact.com>