

VS-15-BU-DSUB-CD-MG

Order No.: 1688926

<http://eshop.phoenixcontact.de/phoenix/treeViewClick.do?UID=1688926>

D-SUB contact carrier, shell size 2, for 15 signal contacts, contact type socket, for crimp contacts, straight, fixing with 4-40 UNC thread, for panel mounting frame VS-15-...

Commercial data

GTIN (EAN)	 4 017918 823078
sales group	D501
Pack	10 pcs.
Customs tariff	85366990
Catalog page information	Page 434 (PC-2011)

Product notes

WEEE/RoHS-compliant since:
03/01/2005



<http://www.download.phoenixcontact.com>
Please note that the data given here has been taken from the online catalog. For comprehensive information and data, please refer to the user documentation. The General Terms and Conditions of Use apply to Internet downloads.

Technical data

General characteristics

Design	15
Degree of protection	IP67
Inflammability class acc. to UL 94	V0
Height	16.8 mm
Housing material	PA
Seal material	Flat gasket: NBR; profile gasket: EPDM
Ambient temperature (operation)	-40 °C ... 80 °C

Accessories

Item	Designation	Description
General		
1688049	VS-15-A-EMV-S	D-SUB EMC shroud, shell size 2, shielded, for panel mounting frame VS-15-...
Protective covers		
1887099	VS-15-SD	D-SUB protective cover, shell size 2, IP54 degree of protection, for panel mounting frame and sleeve housing VS-15-...

Diagrams/Drawings

Dimensioned drawing

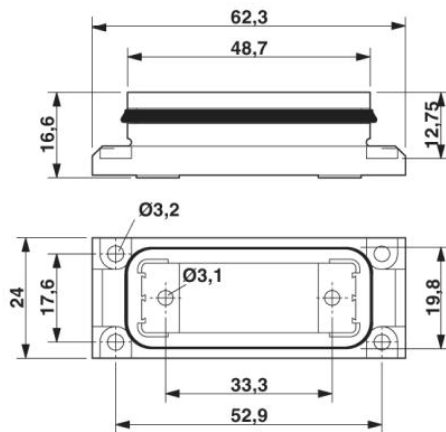

D-SUB panel mounting frame

Address

PHOENIX CONTACT Inc., USA
586 Fulling Mill Road
Middletown, PA 17057, USA
Phone (800) 888-7388
Fax (717) 944-1625
<http://www.phoenixcon.com>



© 2011 Phoenix Contact
Technical modifications reserved;