

## System connection - PLC-V8/D15S/IN - 2296074

Please be informed that the data shown in this PDF Document is generated from our Online Catalog. Please find the complete data in the user's documentation. Our General Terms of Use for Downloads are valid (<http://phoenixcontact.com/download>)



V8 adapter for 8 x PLC-INTERFACE (6.2 mm), controller: PLC system cabling of input cards, connection 1: Screw connection 1x, connection 2: D-SUB pin strip 1x 15-position, connection 3: Plug connection (Can be snapped onto 8x PLC-INTERFACE terminals), number of channels: 8, control logic: positive switching

### Key Commercial Data

Packing unit	1 pc
GTIN	 4 017918 189129
GTIN	4017918189129

### Technical data

#### Dimensions

Width	50 mm
Height	39 mm
Depth	50 mm

#### Ambient conditions

Ambient temperature (operation)	-40 °C ... 70 °C
Ambient temperature (storage/transport)	-40 °C ... 70 °C
Degree of protection	IP20

#### General

Nominal voltage $U_N$	30 V DC
Max. perm. current (per branch)	1 A (per signal path)
Max. permissible current (separate power supply)	3 A
Number of positions	15
Status display	Green LED
Mounting position	any
Degree of protection	IP20

#### Connection data

## System connection - PLC-V8/D15S/IN - 2296074

### Technical data

#### Connection data

Connection name	Supply
Connection in acc. with standard	IEC / EN
Connection method	Screw connection
Stripping length	8 mm
Screw thread	M3
Number of connections	1
Conductor cross section solid	0.2 mm <sup>2</sup> ... 4 mm <sup>2</sup>
Conductor cross section flexible	0.2 mm <sup>2</sup> ... 2.5 mm <sup>2</sup>
Conductor cross section AWG	24 ... 12

#### Connection data 2

Connection name	Controller level
Connection method	D-SUB pin strip
Number of connections	1
Number of positions	15

#### Connection data 3

Connection name	Field level
Connection method	Plug connection
Note	Can be snapped onto 8x PLC-INTERFACE terminals

#### Supported controller

Controller	universal
- suitable I/O card	universal

#### Standards and Regulations

Connection in acc. with standard	CUL
Standards/regulations	IEC 60664
	DIN EN 50178
Rated insulation voltage	50 V
Rated surge voltage	0.5 kV (Functional insulation)
Degree of pollution	2
Overvoltage category	II
Flammability rating according to UL 94	V0

#### Environmental Product Compliance

REACH SVHC	Lead 7439-92-1
China RoHS	Environmentally Friendly Use Period = 50
	For details about hazardous substances go to tab "Downloads", Category "Manufacturer's declaration"

### Drawings

# System connection - PLC-V8/D15S/IN - 2296074

Dimensional drawing

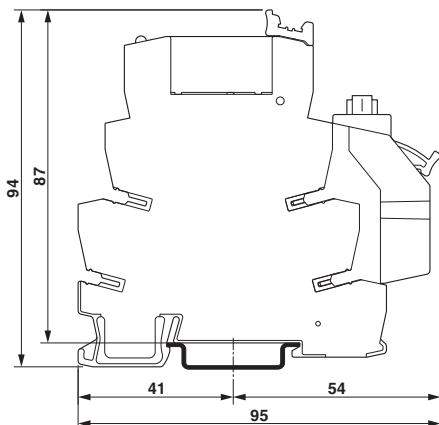

Dimensional drawing

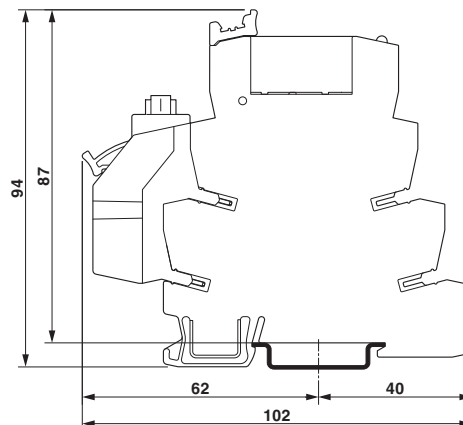

Circuit diagram

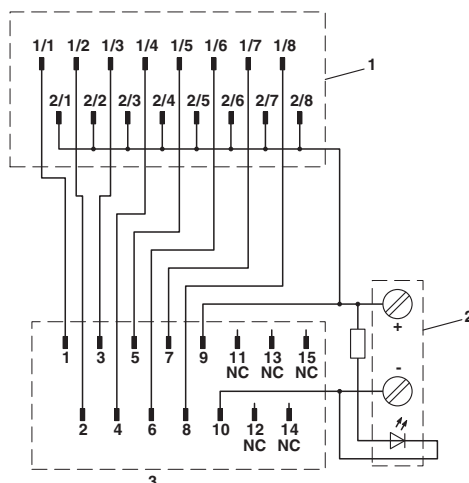

- 1 = contacting with PLC terminal blocks
- 2 = power terminal blocks
- 3 = D-SUB strip 15-pos.

## Approvals

### Approvals

Approvals

PRS / UL Listed / UL Recognized / cUL Recognized / cUL Listed / EAC / DNV GL / cULus Recognized / cULus Listed

Ex Approvals

### Approval details

# System connection - PLC-V8/D15S/IN - 2296074

## Approvals

PRS		<a href="http://www.prs.pl/">http://www.prs.pl/</a>	TE/2109/880590/16
-----	--	---	-------------------

UL Listed		<a href="http://database.ul.com/cgi-bin/XYV/template/LISEXT/1FRAME/index.htm">http://database.ul.com/cgi-bin/XYV/template/LISEXT/1FRAME/index.htm</a>	FILE E 172140
-----------	--	---	---------------

UL Recognized		<a href="http://database.ul.com/cgi-bin/XYV/template/LISEXT/1FRAME/index.htm">http://database.ul.com/cgi-bin/XYV/template/LISEXT/1FRAME/index.htm</a>	FILE E 238705
---------------	--	---	---------------

Nominal voltage UN	24 V
Nominal current IN	1 A

cUL Recognized		<a href="http://database.ul.com/cgi-bin/XYV/template/LISEXT/1FRAME/index.htm">http://database.ul.com/cgi-bin/XYV/template/LISEXT/1FRAME/index.htm</a>	FILE E 238705
----------------	--	---	---------------

Nominal voltage UN	24 V
Nominal current IN	1 A

cUL Listed		<a href="http://database.ul.com/cgi-bin/XYV/template/LISEXT/1FRAME/index.htm">http://database.ul.com/cgi-bin/XYV/template/LISEXT/1FRAME/index.htm</a>	FILE E 172140
------------	--	---	---------------

EAC		RU C- DE.A*30.B.01742
-----	--	--------------------------

DNV GL		<a href="https://approvalfinder.dnvgl.com/">https://approvalfinder.dnvgl.com/</a>	TAE0000196-02
--------	--	---	---------------

cULus Recognized	
------------------	--

cULus Listed	
--------------	--

Phoenix Contact 2019 © - all rights reserved  
<http://www.phoenixcontact.com>

PHOENIX CONTACT GmbH & Co. KG  
Flachmarktstr. 8  
32825 Blomberg  
Germany  
Tel. +49 5235 300  
Fax +49 5235 3 41200  
<http://www.phoenixcontact.com>