

# FLS PB M12 DIO 8/8 M12

Fieldline Stand-Alone device for PROFIBUS DP  
with eight digital inputs  
and eight digital outputs

## AUTOMATION

Data sheet  
6893\_en\_02

© PHOENIX CONTACT - 01/2009

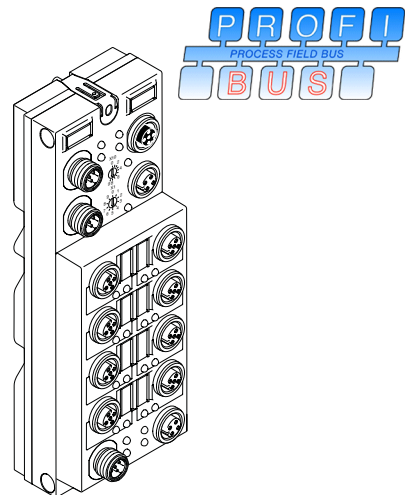

## 1 Description

This device is used to acquire and output digital signals.

### Features

- Connection to PROFIBUS DP using M12 connectors (B-encoded)
- Baud rate with up to 12 Mbaud autobaud
- Connection of digital sensors using M12 connectors
- Connection of digital actuators using M12 connectors
- Flexible power supply concept
- Diagnostic and status indicators
- Short-circuit and overload protection of the outputs and sensor supply
- IP 65/IP 67 protection



Make sure you always use the latest documentation.  
It can be downloaded at [www.phoenixcontact.com](http://www.phoenixcontact.com).



This data sheet is only valid in association with the FLS FLM SYS INST UM E and FLS FLM PB SYS PRO UM E user manuals.

## 2 Ordering data

### Product

Description	Type	Order No.	Pcs./Pkt.
Fieldline Stand-Alone device for PROFIBUS with eight digital inputs and eight digital outputs	FLS PB M12 DIO 8/8 M12	2736372	1

### Accessories

Description	Type	Order No.	Pcs./Pkt.
Protective caps (for unused female connectors)	PROT-M12	1680539	5
Protective caps (for unused male connectors)	PROT-M12-FS	1513596	5
5-pos. shielded female connector, M12 B-encoded, for the incoming remote bus	SACC-M12FSB-5CON-PG9 SH AU	1507777	1
5-pos. shielded male connector, M12 B-encoded, for the outgoing remote bus	SACC-M12MSB-5CON-PG9 SH AU	1507764	1
PROFIBUS M12 T-piece, 12 Mbaud	SAC-M12T/2XM12 PB DP	1507780	1
PROFIBUS M12 termination resistor	SAC-5P-M12MS PB TR	1507803	1
Marking labels	ZBF 12:UNBEDRUCKT	0809735	10



For additional accessories for connecting the sensors and actuators, please refer to the Phoenix Contact PLUSCON catalog.

### Documentation

Description	Type	Order No.	Pcs./Pkt.
"Installation of devices in the Fieldline product range" user manual	FLS FLM SYS INST UM E	-	-
"Configuring a PROFIBUS system using devices in the Fieldline product range" user manual	FLS FLM PB SYS PRO UM E	-	-

## 3 Technical data

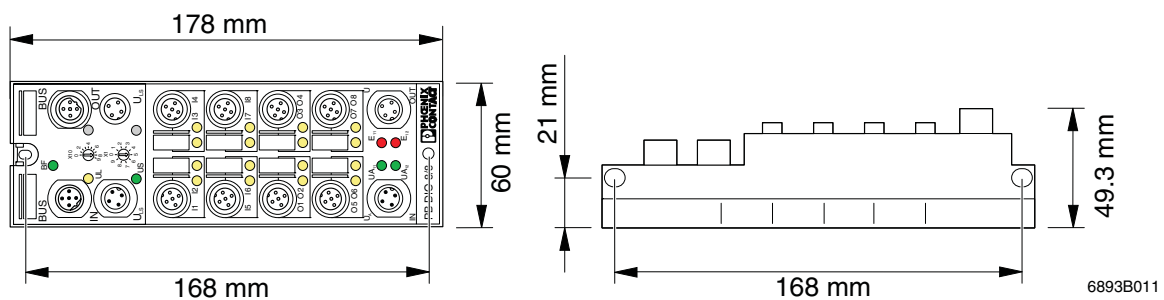

Figure 1 Dimensions of the device

## FLS PB M12 DIO 8/8 M12

### General data

Order designation	FLS PB M12 DIO 8/8 M12
Order No.	2736372
Housing dimensions (width x height x depth)	60 mm x 178 mm x 49.3 mm
Weight	340 g, approximately
Operating mode	Process data mode with 8 bits
Connection method for sensors	2, 3 or 4-wire technology
Connection method for actuators	2 or 3-wire technology
Permissible temperature (operation)	-25°C to +60°C
Permissible temperature (storage/transport)	-25°C to +85°C
Permissible humidity (storage/transport)	95%



For a short period, slight condensation may appear on the outside of the housing.

Permissible air pressure (operation)	80 kPa to 106 kPa (up to 2000 m above sea level)
Permissible air pressure (storage/transport)	70 kPa to 106 kPa (up to 3000 m above sea level)
Degree of protection	IP65/IP67 according to IEC 60529
Protection class	Class 3 according to VDE 0106, IEC 60536

### Mechanical requirements

<b>Vibration test, sinusoidal vibrations according to EN 60068-2-6</b>	5g load in each space direction
Shock test according to EN 60068-2-27	30g load, half sinusoidal wave positive and negative in each space direction



For additional information about mechanical requirements and ambient conditions, please contact Phoenix Contact.

### Power supply

Supply voltage	24 V DC
Range	18 V DC to 30 V DC
Current consumption at $U_{L+}$ at 24 V DC	40 mA, typical (100 mA, maximum)
Current consumption at $U_S$ at 24 V DC	10 mA + sensor current, typical (500 mA, maximum)
Current consumption at $U_{Axx}$ at 24 V DC	6 mA + actuator current, typical (4 A, maximum)

### Digital inputs

Number	8
Input design	According to IEC 61131-2 Type 1
Definition of switching thresholds	
Maximum low-level voltage	$U_{Lmax} < 5 V$
Minimum high-level voltage	$U_{Hmin} > 11 V$
Nominal input voltage	24 V DC
Range	-3 V DC < $U_{IN}$ < +30 V DC
Nominal input current	3 mA, typical
Current flow	Constant
Delay time	$t_{ON} < 3 ms$ , typical $t_{OFF} = 3 ms$ , typical
Permissible cable length to the sensor	30 m

### Sensor supply

Minimum sensor voltage	$U_S - 2 V$
Nominal current per channel	62.5 mA

### Sensor supply (continued)

Nominal current per device	500 mA
Overload protection	Electronic per device
Short-circuit protection	Electronic per device

### Error messages to the higher-level control or computer system

Sensor supply short circuit	Yes
Sensor supply overload	Yes



If an error is triggered by an overload or short circuit of the sensor supply, the device switches off the sensor supply to all the channels and sends an error message to the master.  
If the sensor supply  $U_S$  is too low, the device sends an error message to the master (see "Diagnostic data" on page 13).

Overload of outputs	Yes
---------------------	-----

### Digital outputs

Number	8
Nominal output voltage $U_{OUT}$	$U_{Axx} - 1 V$
Differential voltage at $I_{nom}$	$\leq 1 V$
Nominal current $I_{nom}$ per channel	500 mA
Total current	4 A (observe derating)
Possible output current during short circuit	4 A



Please take this value into account when selecting the power supply unit.

Derating at 100% simultaneity

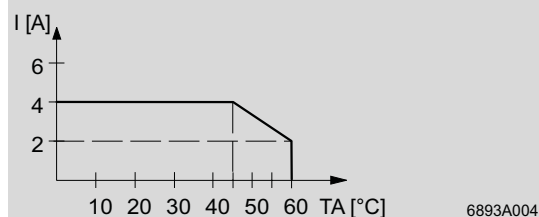

Nominal load per channel	
- Ohmic	12 W
- Inductive	12 VA (1.2 H, 12 $\Omega$ )
- Lamp	12 W
Signal delay upon power up of:	
- Nominal ohmic load	Approximately 500 $\mu$ s, typical
- Nominal inductive load	Depending on inductive time constant
- Nominal lamp load	Approximately 100 ms, typical
Signal delay upon power down of:	
- Nominal ohmic load	1 ms, approximately
- Nominal inductive load	50 ms (1.2 H, 12 $\Omega$ ), approximately; depending on inductive time constant
- Nominal lamp load	1 ms, approximately
Switching frequency with:	
- Nominal ohmic load	300 Hz, maximum



This switching frequency is limited by the number of bus devices, the bus configuration, the software used, and the control or computer system used.

- Nominal inductive load	0.5 Hz (1.2 H, 12 $\Omega$ ), maximum
- Nominal lamp load	8 Hz, maximum

### Digital outputs (continued)

Overload response	Auto restart
Restart frequency with ohmic overload (2 Ω)	400 Hz
Response with inductive overload	Output may be damaged
Reverse voltage protection against short pulses	Protected against reverse voltages
Resistance to permanently applied reverse voltages	Protected against reverse voltages; 2 A, maximum
Response upon power down	The output follows the supply voltage without delay
Validity of output data after connecting the power supply (power up)	5 ms, typical
Limitation of the voltage induced on circuit interruption	-15 V DC ≤ U <sub>demag</sub> ≤ -45.8 V DC
Single maximum energy in free running	400 mJ
Protective circuit type	Integrated 45 V Zener diode with output chip
Overcurrent shutdown	0.7 A, minimum
Output current when switched off	300 μA, maximum
Output current with ground connection interrupt when switched off	25 mA, maximum

### Error messages to the higher-level control or computer system

Overload of outputs	Yes
---------------------	-----



If an error is triggered at the outputs by an overload, the device switches off the corresponding output and sends an error message to the master (see "Diagnostic data for device diagnostics" on page 13).

**Output characteristic curve when switched on (typical)**

Output current (A)	Differential output voltage (V)
0	0
0.10	0.04
0.20	0.08
0.30	0.12
0.40	0.16
0.50	0.20

**Output characteristic curve when switched off ( $U_{Axx} = 30$  V DC, typical)**

Load resistance (k $\Omega$ )	Output voltage (V)
$\infty$	1.5
1000	0.9
100	0.1
10	0.01
1	0.001

**Interface**

Bus system PROFIBUS DP

**Incoming bus**

Coupling of shield connection Directly to FE  
Transmission speed 12 Mbaud, maximum

**Outgoing bus**

Coupling of shield connection Directly to FE  
Transmission speed 12 Mbaud, maximum



For transmission speeds of more than 3 Mbaud, T-pieces with integrated series inductance must be used.

**Electrical isolation/isolation of the voltage areas**



For device connection, please note the instructions and regulations in the "Installation of devices in the Fieldline product range" user manual, FLS FLM SYS INST UM E.

**Separate potentials in the FLS PB M12 DIO 8/8 M12 I/O device**

Test distance	Test voltage
24 V supply (bus logic)/bus connection	500 V AC, 50 Hz, 1 min.
24 V supply (bus logic)/FE	500 V AC, 50 Hz, 1 min.
24 V supply (bus logic)/digital inputs (sensor supply)	500 V AC, 50 Hz, 1 min.
24 V supply (bus logic)/digital outputs (actuator supply)	500 V AC, 50 Hz, 1 min.
Bus connection/FE	500 V AC, 50 Hz, 1 min.
Bus connection/digital inputs (sensor supply)	500 V AC, 50 Hz, 1 min.
Bus connection/digital outputs (actuator supply)	500 V AC, 50 Hz, 1 min.
FE/digital inputs (sensor supply)	500 V AC, 50 Hz, 1 min.
FE/digital outputs (actuator supply)	500 V AC, 50 Hz, 1 min.
Digital outputs (actuator supply)/digital outputs (actuator supply)	500 V AC, 50 Hz, 1 min.

**Approvals**

For the latest approvals, please visit [www.download.phoenixcontact.com](http://www.download.phoenixcontact.com) or [eshop.phoenixcontact.com](http://eshop.phoenixcontact.com).

## 4 Pin assignment

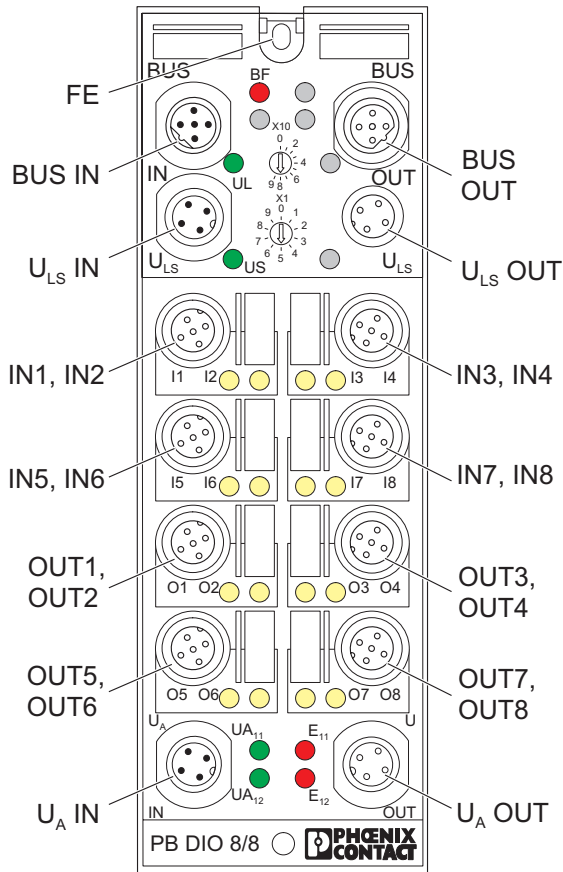

Designation	Meaning
FE	Functional earth ground
BUS IN	PROFIBUS IN
BUS OUT	PROFIBUS OUT
U <sub>LS</sub> IN	Power supply IN (logic and sensors)
U <sub>LS</sub> OUT	Power supply OUT (logic and sensors) for additional devices
IN1 to IN8	Inputs 1 to 8
OUT1 to OUT8	Outputs 1 to 8
U <sub>A</sub> IN	Power supply IN of the outputs (OUT1 to OUT8) with voltages U <sub>A11</sub> and U <sub>A12</sub>
U <sub>A</sub> OUT	Power supply OUT for additional devices

Figure 2 Connections of the FLS PB M12 DIO 8/8 M12

6893A002

#### 4.1 Pin assignment of the PROFIBUS connection

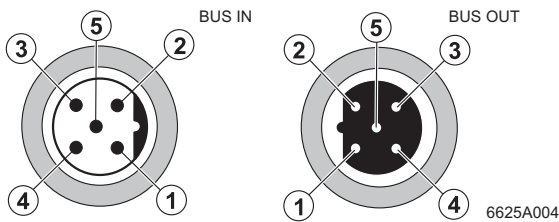

Figure 3 PROFIBUS pin assignment (M12 B-encoded)

Pin	IN	OUT
1	VP	VP
2	RxD/TxD-N (A)	RxD/TxD-N (A)
3	DGND	DGND
4	RxD/TxD-P (B)	RxD/TxD-P (B)
5	Shield	Shield



The thread is used for additional shielding.

#### 4.2 Pin assignment of the power supply $U_{LS}$

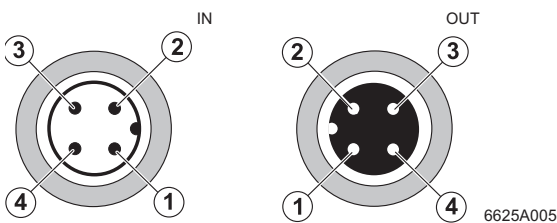

Figure 4 Pin assignment of the power supply  $U_{LS}$

Pin	IN	OUT
1	$U_L +24\text{ V}$	$U_L +24\text{ V}$
2	$U_S\text{ GND}$	$U_S\text{ GND}$
3	$U_L\text{ GND}$	$U_L\text{ GND}$
4	$U_S +24\text{ V}$	$U_S +24\text{ V}$

#### 4.3 Pin assignment of the power supply $U_A$ of the outputs

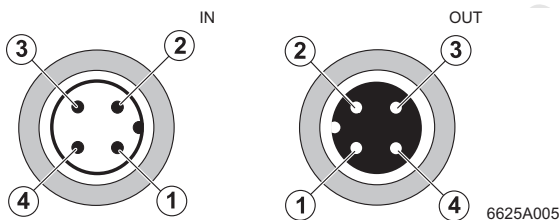

Figure 5 Pin assignment of the power supply  $U_A$  of the outputs

Pin	IN	OUT
1	$U_{A11} +24\text{ V}$	$U_{A11} +24\text{ V}$
2	$U_{A12}\text{ GND}$	$U_{A12}\text{ GND}$
3	$U_{A11}\text{ GND}$	$U_{A11}\text{ GND}$
4	$U_{A12} +24\text{ V}$	$U_{A12} +24\text{ V}$

#### Pin assignment of the inputs and outputs

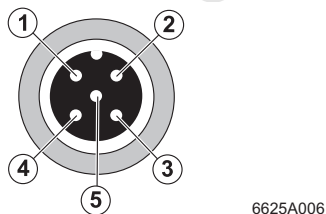
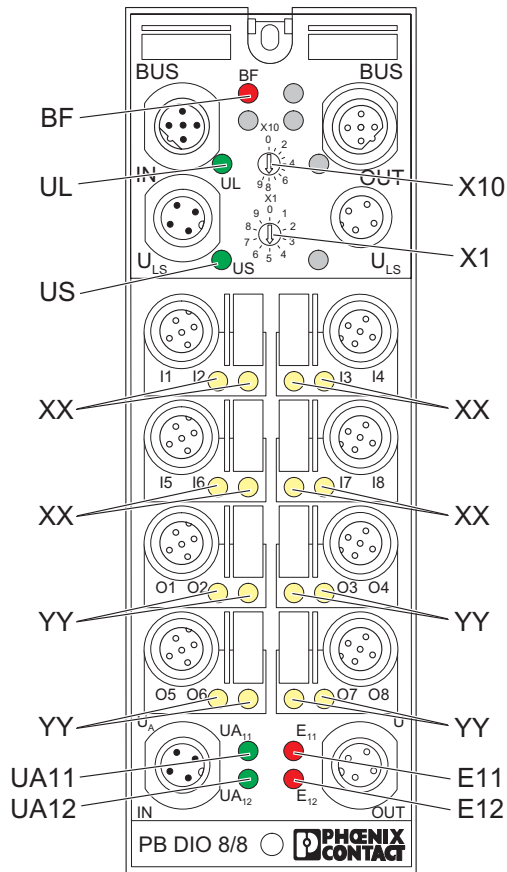

Figure 6 Pin assignment of the inputs and outputs

Pin	Female input connector	Female output connector
1	$U_S +24\text{ V}$	Not used
2	Input 2, 4, 6, 8	Output 2, 4, 6, 8
3	GND	GND
4	Input 1, 3, 5, 7	Output 1, 3, 5, 7
5	FE	FE

## 5 Local diagnostic and status indicators



6893A003

Figure 7 Indicators and rotary encoding switches of the FLS PB M12 DIO 8/8 M12

### Rotary encoding switches

The station address is set using rotary encoding switches X10 (for tens) and X1 (for units). The PROFIBUS master addresses the device by means of this station address.



The valid value range is between 1 and 99.  
A new address value is only applied on device power up.

Designation	Color	Meaning
<b>BF</b>	Red LED	Bus error (bus failure)
	ON:	No cyclic data transmission: <ul style="list-style-type: none"> <li>- PROFIBUS not connected, master not active</li> <li>- Incorrect settings (configuration via master, station address)</li> <li>- Synchronization or parameterization running</li> <li>- Timeout elapsed</li> </ul>
	OFF:	- Device is addressed by PROFIBUS and is in the "cyclic process data exchange" state - Device supply not present (In this state the "UL" LED is also off due to the missing 24 V communications power.)
<b>UL</b>	Green LED	Communications power
	ON:	Communications power present
	OFF:	Communications power too low
<b>US</b>	Red/green LED	Power supply for IN1 to IN8
	ON (red):	Power supply for IN1 to IN8 overloaded
	ON (green):	Power supply for IN1 to IN8 present
	OFF:	Power supply for IN1 to IN8 too low
<b>XX</b>	Yellow LED	Status indicators for the inputs
	ON:	Input active
	OFF:	Input not active
<b>YY</b>	Yellow LED	Status indicators for the outputs
	ON:	Output active
	OFF:	Output not active
<b>UA11</b>	Green LED	Power supply for OUT1 to OUT4
	ON:	Power supply for OUT1 to OUT4 present
	OFF:	Power supply for OUT1 to OUT4 too low
<b>UA12</b>	Green LED	Power supply for OUT5 to OUT8
	ON:	Power supply for OUT5 to OUT8 present
	OFF:	Power supply for OUT5 to OUT8 too low
<b>E11</b>	Red LED	Short circuit/overload of OUT1 to OUT4
	ON:	Output is short circuited/overloaded
	OFF:	Output is not short circuited/overloaded
<b>E12</b>	Red LED	Short circuit/overload of OUT5 to OUT8
	ON:	Output is short circuited/overloaded
	OFF:	Output is not short circuited/overloaded

## 6 Internal basic circuit diagram

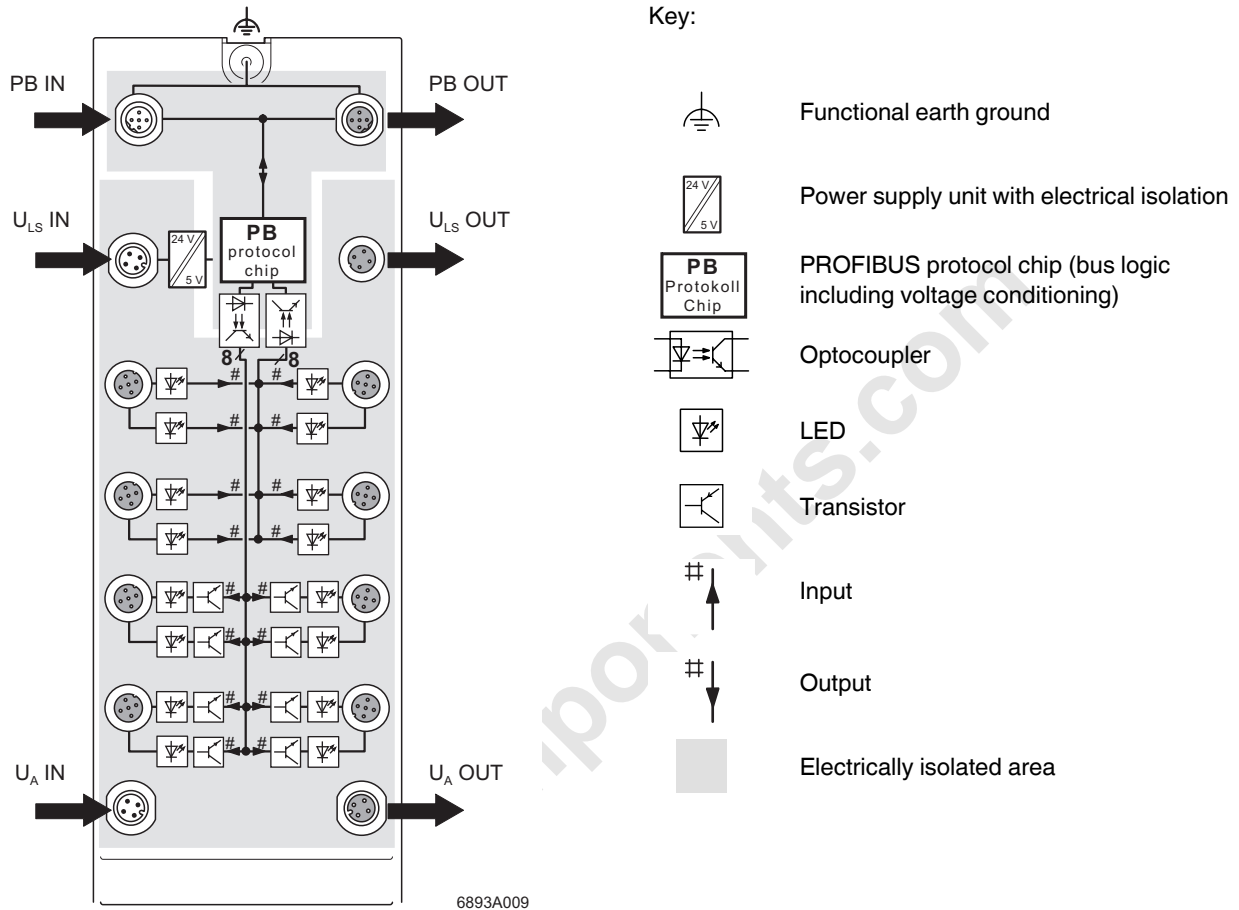

Figure 8 Internal wiring of the connections



For information about the electrically isolated areas, please refer to page 6.

## 7 Connection example

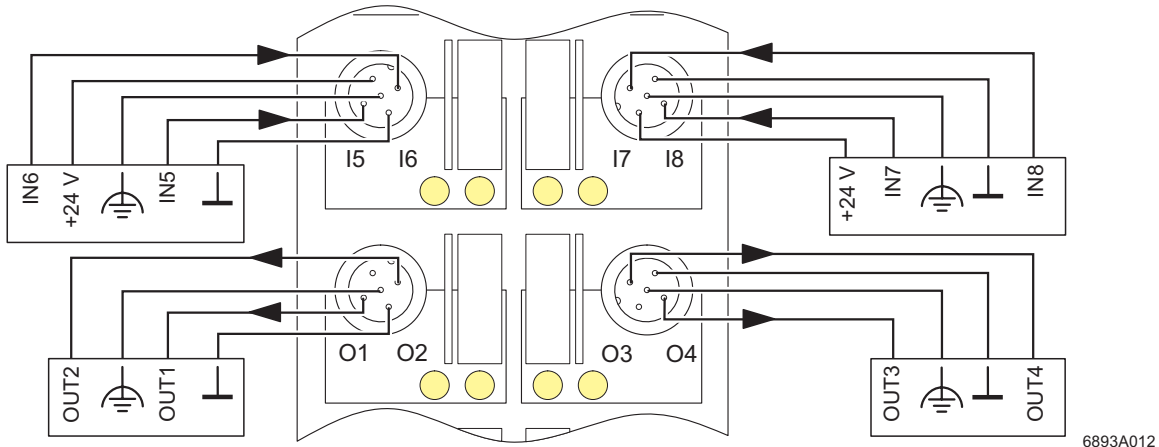

Figure 9 Typical connection of sensors and actuators

## 8 Connection notes



**NOTE: Meet noise immunity requirements**

Connect FE using a mounting screw or a cable connection to the FE connection latch (when mounting on the side or on a non-conductive surface).



**NOTE: Ensure degree of protection**

To ensure IP65/IP67 protection, cover unused female connectors with protective caps.



**NOTE: Avoid damage to the electronics**

Only supply the sensors with the voltage  $U_S$  provided at the terminal points.



**NOTE: Avoid polarity reversal**

Avoid polarity reversal of the supply voltages  $U_L$ ,  $U_S$ , and  $U_A$  in order to prevent damage to the device.



**NOTE: Observe connection assignment**

When connecting the sensors and actuators, observe the assignment of the connections to the PROFIBUS input and output data (see "Process data" on page 13).

## 9 Configuration data

ID number	06FD <sub>hex</sub>
Input address area	8 bits
Output address area	8 bits

## 10 Process data

### 10.1 Assignment of the terminal points to the IN process data

(Byte.bit) view	Byte	Byte 0							
	Bit	7	6	5	4	3	2	1	0
Device	Input	8	7	6	5	4	3	2	1

### 10.2 Assignment of the terminal points to the OUT process data

(Byte.bit) view	Byte	Byte 0							
	Bit	7	6	5	4	3	2	1	0
Device	Output	8	7	6	5	4	3	2	1

## 11 Diagnostic data

### 11.1 Mapping of diagnostic data in PROFIBUS

Diagnostic data	Bit 7	Bit 6	Bit 5	Bit 4	Bit 3	Bit 2	Bit 1	Bit 0	Remark
Byte 0	X	X	X	X	X	X	X	X	Station status 1
Byte 1	X	X	X	X	X	X	X	X	Station status 2
Byte 2	X	X	X	X	X	X	X	X	Station status 3
Byte 3	X	X	X	X	X	X	X	X	Diagnostic master address
Byte 4	0	0	0	0	0	1	1	0	High ID number
Byte 5	0	1	1	0	1	0	1	0	Low ID number
Byte 6	0	0	0	0	0	1	1	1	Diagnostic header
Byte 7	M.7	M.6	M.5	M.4	M.3	M.2	M.1	M.0	Device diagnostics
Byte 8	0	0	0	0	0	0	0	0	Reserved
Byte 9	0	0	0	0	0	0	0	0	Reserved
Byte 10	0	0	0	0	0	0	0	0	Reserved
Byte 11	0	0	0	0	0	0	0	0	Reserved
Byte 12	X	X	0	0	0	0	0	0	Reserved



Bytes 0 to 6 are PROFIBUS standard. Bytes 7 to 12 are device-specific.

### 11.2 Diagnostic data for device diagnostics

Bit	Remark	Assignment
M.0 - M.2	Reserved	0
M.3	Status of the sensor supply $U_S$	1, if $U_S$ is too low
M.4	Reserved	0
M.5	Overload status of the outputs	OUT1 to OUT8
M.6	Status of the device supply $U_L$	1, if $U_L$ too low
M.7	Overload status of the sensor supply $U_S$	1, if sensor supply is overloaded



If a diagnostic event occurs, the diagnostic data is sent to the master by means of a diagnostic telegram generated once by the device. The current status of the data can be read by the device at any time.