

# Lightning/surge arrester type 1/2 - VAL-MS-T1/T2 335/12.5/3+1 - 2800184

Please be informed that the data shown in this PDF Document is generated from our Online Catalog. Please find the complete data in the user's documentation. Our General Terms of Use for Downloads are valid (<http://phoenixcontact.com/download>)



Universal varistor-based plug-in lightning/surge arrester for 3-phase power supply networks with separate N and PE (5-conductor system: L1, L2, L3, N, PE), for Lightning Protection Levels III and IV.

## Your advantages

- ✓ Plugs can be checked with CHECKMASTER
- ✓ Secure hold of plugs in the event of high lightning current loads and strong vibrations thanks to new latching
- ✓ Optical, mechanical status indication for the individual arresters
- ✓ Pluggable
- ✓ Thermal disconnect device for each individual plug
- ✓ Mechanical coding of all slots



## Key Commercial Data

Packing unit	1 pc
GTIN	 4 046356 518567
GTIN	4046356518567

## Technical data

### Dimensions

Height	89.8 mm
Width	71.2 mm
Depth	77.5 mm (incl. DIN rail 7.5 mm)
Horizontal pitch	4 Div.

### Ambient conditions

Degree of protection	IP20 (only when all terminal points are used)
Ambient temperature (operation)	-40 °C ... 80 °C
Ambient temperature (storage/transport)	-40 °C ... 80 °C

# Lightning/surge arrester type 1/2 - VAL-MS-T1/T2 335/12.5/3+1 - 2800184

## Technical data

### Ambient conditions

Altitude	≤ 2000 m (amsl (above mean sea level))
Permissible humidity (operation)	5 % ... 95 %
Shock (operation)	30g (Half-sine / 11 ms / 3x ±X, ±Y, ±Z)
Vibration (operation)	7.5g (10 ... 500 Hz / 2.5 h / X, Y, Z)

### General

IEC test classification	I / II
	T1 / T2
	T1
	I
EN type	T1 / T2
	T1
IEC power supply system	TT
	TN-S
Mode of protection	L-N
	L-PE
	N-PE
Mounting type	DIN rail: 35 mm
Color	jet black RAL 9005
Housing material	PA 6.6
	PBT
Degree of pollution	2
Flammability rating according to UL 94	V-0
Type	DIN rail module, two-section, divisible
Number of positions	4
Surge protection fault message	optical

### Protective circuit

Nominal voltage $U_N$	240/415 V AC (TN-S)
	240/415 V AC (TT)
Nominal frequency $f_N$	50 Hz (60 Hz)
Maximum continuous operating voltage $U_C$ (L-N)	335 V AC
Maximum continuous operating voltage $U_C$ (L-PE)	335 V AC
Maximum continuous voltage $U_C$ (N-PE)	264 V AC
Rated load current $I_L$	80 A
Residual current $I_{PE}$	≤ 5 μA
Standby power consumption $P_C$	≤ 810 mVA
Nominal discharge current $I_n$ (8/20) μs (L-N)	12.5 kA
Nominal discharge current $I_n$ (8/20) μs (L-PE)	12.5 kA
Nominal discharge current $I_n$ (8/20) μs (N-PE)	50 kA

# Lightning/surge arrester type 1/2 - VAL-MS-T1/T2 335/12.5/3+1 - 2800184

## Technical data

### Protective circuit

Maximum discharge current $I_{max}$ (8/20) $\mu$ s	50 kA
Impulse discharge current (10/350) $\mu$ s (L-N), charge	6.25 As
Impulse discharge current (10/350) $\mu$ s (L-N), specific energy	39 kJ/ $\Omega$
Impulse discharge current (10/350) $\mu$ s (L-N), peak current value $I_{imp}$	12.5 kA
Impulse discharge current (10/350) $\mu$ s (L-PE), charge	6.25 As
Impulse discharge current (10/350) $\mu$ s (L-PE), specific energy	39 kJ/ $\Omega$
Impulse discharge current (10/350) $\mu$ s (L-PE), peak current value $I_{imp}$	12.5 kA
Impulse discharge current (10/350) $\mu$ s (N-PE), charge	25 As
Impulse discharge current (10/350) $\mu$ s (N-PE), specific energy	625 kJ/ $\Omega$
Impulse discharge current (10/350) $\mu$ s (N-PE), peak current value $I_{imp}$	50 kA
Total discharge current $I_{total}$ (8/20) $\mu$ s	50 kA
Total discharge current $I_{total}$ (10/350) $\mu$ s	50 kA
Follow current interrupt rating $I_{fi}$ (N-PE)	100 A
Short-circuit current rating $I_{SCCR}$	25 kA
Voltage protection level $U_p$ (L-N)	$\leq 1.2$ kV
	$\leq 1.6$ kV (30 kA - 8/20 $\mu$ s)
Voltage protection level $U_p$ (L-PE)	$\leq 2$ kV
Voltage protection level $U_p$ (N-PE)	$\leq 1.7$ kV
Residual voltage $U_{res}$ (L-N)	$\leq 1.2$ kV (at $I_n$ )
	$\leq 1.1$ kV (at 10 kA)
	$\leq 1$ kV (at 5 kA)
	$\leq 0.9$ kV (at 3 kA)
Residual voltage $U_{res}$ (L-PE)	$\leq 2$ kV (at $I_n$ )
	$\leq 1.5$ kV (at 10 kA)
	$\leq 1.2$ kV (at 5 kA)
	$\leq 1.1$ kV (at 3 kA)
Residual voltage $U_{res}$ (N-PE)	$\leq 0.6$ kV (at $I_n$ )
	$\leq 0.5$ kV (at 10 kA)
	$\leq 0.5$ kV (at 5 kA)
	$\leq 0.4$ kV (at 3 kA)
TOV behavior at $U_T$ (L-N)	415 V AC (5 s / withstand mode)
	457 V AC (120 min / safe failure mode)
TOV behavior at $U_T$ (N-PE)	1200 V AC (200 ms / withstand mode)
Response time $t_A$ (L-N)	$\leq 25$ ns
Response time $t_A$ (L-PE)	$\leq 100$ ns
Response time $t_A$ (N-PE)	$\leq 100$ ns
Max. backup fuse with V-type through wiring	80 A (gG - 16 mm <sup>2</sup> )
Max. backup fuse with branch wiring	160 A (gG)

# Lightning/surge arrester type 1/2 - VAL-MS-T1/T2 335/12.5/3+1 - 2800184

## Technical data

### Connection data

Connection method	Screw connection
Screw thread	M5
Tightening torque	3 Nm (1,5 mm <sup>2</sup> ... 16 mm <sup>2</sup> )
	4.5 Nm (25 mm <sup>2</sup> ... 35 mm <sup>2</sup> )
Stripping length	16 mm
Conductor cross section flexible	1.5 mm <sup>2</sup> ... 25 mm <sup>2</sup>
Conductor cross section solid	1.5 mm <sup>2</sup> ... 35 mm <sup>2</sup>
Conductor cross section AWG	15 ... 2
Connection method	Fork-type cable lug
Conductor cross section flexible	1.5 mm <sup>2</sup> ... 16 mm <sup>2</sup>

### UL specifications

SPD Type	4CA
Maximum continuous operating voltage MCOV (L-L)	670 V AC
Maximum continuous operating voltage MCOV (L-N)	335 V AC
Maximum continuous operating voltage MCOV (L-G)	335 V AC
Maximum continuous operating voltage MCOV (N-G)	264 V AC
Nom. voltage	415/240 V AC
Mode of protection	L-L
	L-N
	L-G
	N-G
Power distribution system	3Y
Nominal frequency	50/60 Hz
Measured limiting voltage MLV (L-L)	3570 V
Measured limiting voltage MLV (L-N)	2630 V
Measured limiting voltage MLV (L-G)	3600 V
Measured limiting voltage MLV (N-G)	2600 V
Nominal discharge current I <sub>n</sub> (L-L)	20 kA
Nominal discharge current I <sub>n</sub> (L-N)	20 kA
Nominal discharge current I <sub>n</sub> (L-G)	20 kA
Nominal discharge current I <sub>n</sub> (N-G)	20 kA

### UL connection data

Conductor cross section AWG	10 ... 2
Tightening torque	30 lb <sub>F</sub> -in.

### Standards and Regulations

Standards/regulations	IEC 61643-11 2011
	EN 61643-11 2012

# Lightning/surge arrester type 1/2 - VAL-MS-T1/T2 335/12.5/3+1 - 2800184

## Technical data

### Environmental Product Compliance

China RoHS	Environmentally friendly use period: unlimited = EFUP-e
	No hazardous substances above threshold values

## Drawings

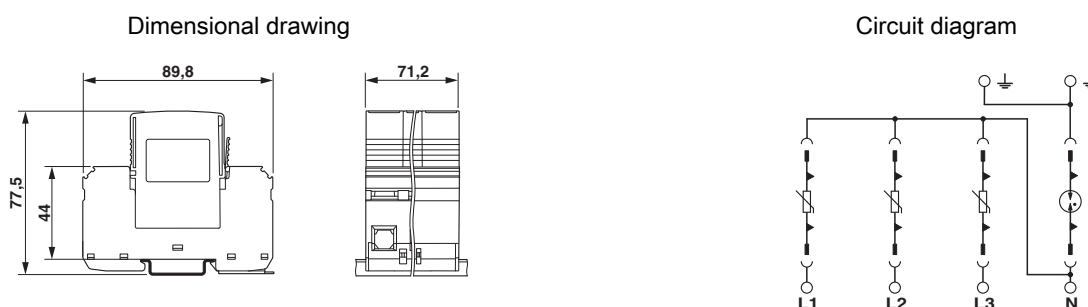

## Approvals

### Approvals

#### Approvals

KEMA-KEUR / ÖVE / CCA / IECCE CB Scheme / UL Recognized / cUL Recognized / EAC / DNV GL / cULus Recognized

#### Ex Approvals

### Approval details

KEMA-KEUR		<a href="http://www.dekra-certification.com">http://www.dekra-certification.com</a>	2162496-01
-----------	--	---	------------

ÖVE		<a href="https://www.ove.at/en/certification-pz/certification-register/">https://www.ove.at/en/certification-pz/certification-register/</a>	18583-009-06
-----	--	---	--------------

CCA			NTR-AT 1906
-----	--	--	-------------

IECEE CB Scheme		<a href="http://www.iecee.org/">http://www.iecee.org/</a>	AT 2584
-----------------	--	---	---------

# Lightning/surge arrester type 1/2 - VAL-MS-T1/T2 335/12.5/3+1 - 2800184

## Approvals

UL Recognized		<a href="http://database.ul.com/cgi-bin/XYV/template/LISEXT/1FRAME/index.htm">http://database.ul.com/cgi-bin/XYV/template/LISEXT/1FRAME/index.htm</a>	FILE E 330181
---------------	--	---	---------------

cUL Recognized		<a href="http://database.ul.com/cgi-bin/XYV/template/LISEXT/1FRAME/index.htm">http://database.ul.com/cgi-bin/XYV/template/LISEXT/1FRAME/index.htm</a>	FILE E 330181
----------------	--	---	---------------

EAC			RU C- DE.A*30.B01561
-----	--	--	-------------------------

DNV GL		<a href="http://exchange.dnv.com/tari/">http://exchange.dnv.com/tari/</a>	TAE00001N9
--------	--	---	------------

cULus Recognized		<a href="http://database.ul.com/cgi-bin/XYV/template/LISEXT/1FRAME/index.htm">http://database.ul.com/cgi-bin/XYV/template/LISEXT/1FRAME/index.htm</a>	
------------------	--	---	--

Phoenix Contact 2018 © - all rights reserved  
<http://www.phoenixcontact.com>

PHOENIX CONTACT GmbH & Co. KG  
Flachsmarktstr. 8  
32825 Blomberg  
Germany  
Tel. +49 5235 300  
Fax +49 5235 3 41200  
<http://www.phoenixcontact.com>