

Type 2 surge protection plug - VAL-US 690 ST - 2800744

Please be informed that the data shown in this PDF Document is generated from our Online Catalog. Please find the complete data in the user's documentation. Our General Terms of Use for Downloads are valid (<http://phoenixcontact.com/download>)



Surge protection connector type 2 with high-capacity varistor for VAL-MS base element, thermal monitoring, visual fault warning. Design: 690 V AC



Key Commercial Data

Packing unit	10 STK
GTIN	 4 046356 641944
GTIN	4046356641944

Technical data

Dimensions

Height	52.4 mm
Width	17.5 mm
Depth	55.3 mm
Horizontal pitch	1 Div.

Ambient conditions

Degree of protection	IP20
Ambient temperature (operation)	-40 °C ... 80 °C
Ambient temperature (storage/transport)	-40 °C ... 80 °C
Altitude	≤ 2000 m (amsl (above mean sea level))
Permissible humidity (operation)	5 % ... 95 %
Shock (operation)	25g (Half-sine / 11 ms / 3x ±X, ±Y, ±Z)
Vibration (operation)	5g (10 ... 500 Hz / 2.5 h / X, Y, Z)

General

IEC test classification	II
	T2
EN type	T2
Mode of protection	L-PE

Type 2 surge protection plug - VAL-US 690 ST - 2800744

Technical data

General

	L-PEN
Mounting type	on base element
Color	jet black RAL 9005
Housing material	PA 6.6
Degree of pollution	2
Distance between live and grounded parts	8 mm
Flammability rating according to UL 94	V-0
Type	Male
Number of positions	1
Surge protection fault message	optical

Additional descriptions

Note	Usable in all low-voltage systems between L-N or L-PEN. Only usable in IT Systems between L-PE, if the exposed-conductive-parts (bodies) of the equipment of the low-voltage installation is connected to the earthing arrangement of the transformer substation. (interconnected earthing arrangement of the HV-transformer substation with the bodies of the LV-installation. $R_E = R_A$ accordance to IEC 60364-4-442 / VDE 0100-442 Fig. 44D / Example a)
------	---

Protective circuit

Nominal voltage U_N	554/960 V AC (TN)
	690 V AC (IT)
Nominal frequency f_N	60 Hz (50 Hz)
Maximum continuous voltage U_C	760 V AC
Residual current I_{PE}	≤ 0.5 mA
Standby power consumption P_C	≤ 400 mVA
Nominal discharge current I_n (8/20) μ s	15 kA
Maximum discharge current I_{max} (8/20) μ s	30 kA
Short-circuit current rating I_{SCCR}	25 kA
Voltage protection level U_p	≤ 2.9 kV
Residual voltage U_{res}	≤ 2.9 kV (at I_n)
	≤ 2.7 kV (at 10 kA)
	≤ 2.5 kV (at 5 kA)
	≤ 2.3 kV (at 3 kA)
TOV behavior at U_T	1000 V AC (5 s / withstand mode)
	1056 V AC (120 min / safe failure mode)
Response time t_A	≤ 25 ns
Max. backup fuse with branch wiring	100 A (gG)

Connection data

Connection method	VALVETRAB plug-in system
-------------------	--------------------------

UL specifications

Type 2 surge protection plug - VAL-US 690 ST - 2800744

Technical data

UL specifications

SPD Type	4CA
Maximum continuous operating voltage MCOV (L-N)	750 V AC
Nom. voltage	690 V AC
Mode of protection	L-N
Power distribution system	1
Nominal frequency	50/60 Hz
Measured limiting voltage MLV (L-N)	2700 V
Nominal discharge current I _n (L-N)	10 kA

Standards and Regulations

Standards/regulations	IEC 61643-11 2011
	EN 61643-11 2012

Drawings

Dimensional drawing

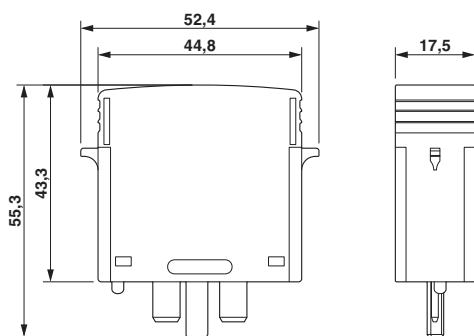

Circuit diagram



Approvals

Approvals

Approvals

UL Recognized / cUL Recognized / EAC / CSA / cULus Recognized

Ex Approvals

Approval details

UL Recognized		http://database.ul.com/cgi-bin/XYV/template/LISEXT/1FRAME/index.htm	FILE E 330181
---------------	--	---	---------------

Type 2 surge protection plug - VAL-US 690 ST - 2800744

Approvals

cUL Recognized		http://database.ul.com/cgi-bin/XYV/template/LISEXT/1FRAME/index.htm	FILE E 330181
----------------	---	---	---------------

EAC			RU C- DE.A*30.B01561
-----	---	--	-------------------------

CSA		http://www.csagroup.org/services-industries/product-listing/	13631
-----	---	---	-------

cULus Recognized		http://database.ul.com/cgi-bin/XYV/template/LISEXT/1FRAME/index.htm	
------------------	---	---	--

Phoenix Contact 2018 © - all rights reserved
<http://www.phoenixcontact.com>

PHOENIX CONTACT GmbH & Co. KG
Flachsmarktstr. 8
32825 Blomberg
Germany
Tel. +49 5235 300
Fax +49 5235 3 41200
<http://www.phoenixcontact.com>