

## Surge protection device - PT-IQ-1X2+F-24DC-UT - 2800977

Please be informed that the data shown in this PDF Document is generated from our Online Catalog. Please find the complete data in the user's documentation. Our General Terms of Use for Downloads are valid (<http://download.phoenixcontact.com>)



Surge protection, consisting of protective plug and base element, with integrated multi-stage status indicator on the module for one 2-wire floating signal circuit. Indirect grounding via gas-filled surge arrester.

### Why buy this product

- Surge protection system
- Multi-level state monitoring
- Collective message about supply and remote module
- System supplied via DIN rail bus
- Up to 28 protection modules per supply module
- Maximum ease of maintenance thanks to the two-piece design
- Codable plug
- Impedance-neutral disconnection of plug for maintenance purposes
- Base element remains an integral part of the installation



### Key commercial data

Packing unit	0
Minimum order quantity	1
GTIN	 4 046356 665179
Custom tariff number	85363010
Country of origin	GERMANY

### Technical data

Design	DIN rail module, two-section, divisible
Direction of action	Line-Line & Line-Signal Ground/Shield & optional Signal Ground/ Shield-Earth Ground

### General

Housing material	PA 6.6
Inflammability class according to UL 94	V0
Ambient temperature (operation)	-40 °C ... 70 °C
Ambient temperature (storage/transport)	-40 °C ... 85 °C
Mounting type	DIN rail mounting

# Surge protection device - PT-IQ-1X2+F-24DC-UT - 2800977

## Technical data

### General

Design	DIN rail module, two-section, divisible
Degree of protection	IP20
Direction of action	Line-Line & Line-Signal Ground/Shield & optional Signal Ground/ Shield-Earth Ground
Width	17.7 mm
Height	91.1 mm
Depth	77.5 mm
Pitch unit	1 Div.

### Protective circuit

IEC category	C1
IEC category	C2
IEC category	C3
IEC category	D1
Nominal voltage UN	24 V
Maximum continuous operating voltage UC	30 V DC
Maximum continuous operating voltage UC	21 V AC
Nominal current IN	1000 mA (Up to 45°C)
Operating effective current IC at UC	≤ 2 mA (per system)
Ground conductor current IPE	≤ 1 µA
Nominal discharge surge current In (8/20) µs (Core-Core)	10 kA
Nominal discharge surge current In (8/20) µs (Core-Earth)	10 kA
Lightning test current (10/350) µs, peak value limp	2.5 kA
Protection level UP (Core-Core)	≤ 80 V (C1 - 1 kV/500 A)
Protection level UP (Core-Core)	≤ 130 V (C2 - 10 kV / 5 kA)
Protection level UP (Core-Core)	≤ 140 V (C2 - 10 kA)
Protection level UP (Core-Core)	≤ 55 V (C3 - 25 A)
Protection level UP (Core-Core)	≤ 60 V (C3 - 100 A)
Protection level UP (Core-Earth)	≤ 900 V (C1 - 1 kV/500 A)
Protection level UP (Core-Earth)	≤ 1300 V (C2 - 10 kV / 5 kA)
Protection level UP (Core-Earth)	≤ 1200 V (C2 - 10 kA)
Protection level UP (Core-Earth)	≤ 1000 V (C3 - 25 A)
Protection level UP (Core-Earth)	≤ 1300 V (C3 - 100 A)
Protection level UP (Core-GND)	≤ 600 V (C1 - 1 kV/500 A)
Protection level UP (Core-GND)	≤ 750 V (C2 - 10 kV / 5 kA)
Protection level UP (Core-GND)	≤ 800 V (C2 - 10 kA)
Protection level UP (Core-GND)	≤ 700 V (C3 - 25 A)
Protection level UP (Core-GND)	≤ 800 V (C3 - 100 A)
Protection level UP static (core-core)	≤ 64 V (C1 - 1 kV/500 A)
Response time tA (Core-Core)	≤ 1 ns
Response time tA (Core-Earth)	≤ 100 ns
Response time tA (Core-Earth)	≤ 100 ns
Input attenuation aE, sym.	Typ. 0.3 dB (≤ 270 kHz)
Cut-off frequency fg (3 dB), sym. in 150 Ohm system	Typ. 1.1 MHz

# Surge protection device - PT-IQ-1X2+F-24DC-UT - 2800977

## Technical data

### Protective circuit

Capacity (Core-Earth)	2 nF
Resistance in series	1.2 Ω ±5%
Message: Surge protection fault	Optical, multi-stage
Max. required back-up fuse	1 A (FF)
Surge carrying capacity in acc. with IEC 61643-21 (Core-Core)	C1 (1 kV/500 A)
Surge carrying capacity in acc. with IEC 61643-21 (Core-Core)	C2 (10 kV/5 kA)
Surge carrying capacity in acc. with IEC 61643-21 (Core-Core)	C2 (10 kA)
Surge carrying capacity in acc. with IEC 61643-21 (Core-Core)	C3 (25 A)
Surge carrying capacity in acc. with IEC 61643-21 (Core-Core)	C3 (50 A)
Surge carrying capacity in acc. with IEC 61643-21 (Core-Core)	C3 (100 A)
Surge carrying capacity in acc. with IEC 61643-21 (Core-Earth)	C1 (1 kV / 500 A)
Surge carrying capacity in acc. with IEC 61643-21 (Core-Earth)	C2 (10 kV / 5 kA)
Surge carrying capacity in acc. with IEC 61643-21 (Core-Earth)	C2 (10 kA)
Surge carrying capacity in acc. with IEC 61643-21 (Core-Earth)	C3 (25 A)
Surge carrying capacity in acc. with IEC 61643-21 (Core-Earth)	C3 (50 A)
Surge carrying capacity in acc. with IEC 61643-21 (Core-Earth)	C3 (100 A)
Surge carrying capacity in acc. with IEC 61643-21 (Core-Earth)	D1 (2.5 kA)
Surge carrying capacity in acc. with IEC 61643-21 (Core-GND)	C1 (1 kV/500 A)
Surge carrying capacity in acc. with IEC 61643-21 (Core-GND)	C2 (10 kV/5 kA)
Surge carrying capacity in acc. with IEC 61643-21 (Core-GND)	C2 (10 kA)
Surge carrying capacity in acc. with IEC 61643-21 (Core-GND)	C3 (25 A)
Surge carrying capacity in acc. with IEC 61643-21 (Core-GND)	C3 (50 A)
Surge carrying capacity in acc. with IEC 61643-21 (Core-GND)	C3 (100 A)
Pulse reset time $t_r$ in acc. with IEC 61643-21 (Core-Core)	≤ 4000 ms
Pulse reset time $t_r$ in acc. with IEC 61643-21 (Core-Earth)	≤ 30 ms
Pulse reset time $t_r$ in acc. with IEC 61643-21 (Core-GND)	≤ 2600 ms
Overload failure mode as per IEC 61643-21 (plug)	Mode 2
Overload failure mode as per IEC 61643-21 (GND-Ground base element)	Mode 2

### Connection data

Connection method	Screw connection
Connection type IN	Screw terminal blocks
Connection type OUT	Screw terminal blocks
Tightening torque	0.5 Nm
Stripping length	8 mm
Conductor cross section solid min.	0.2 mm <sup>2</sup>
Conductor cross section solid max.	4 mm <sup>2</sup>
Conductor cross section AWG/kcmil min.	24
Conductor cross section AWG/kcmil max	12

### Connection, equipotential bonding

Connection method	NS 35 DIN rail or connection terminal block
-------------------	---

# Surge protection device - PT-IQ-1X2+F-24DC-UT - 2800977

## Classifications

### eclass

eCl@ss 5.1	27130801
eCl@ss 6.0	27130807
eCl@ss 7.0	27130807

### etim

ETIM 4.0	EC000943
ETIM 5.0	EC000943

## Accessories

### Accessories

#### Marking

Marker pen - X-PEN 0,35 - 0811228



Marker pen without ink cartridge, for manual labeling of markers, labeling extremely wipe-proof, line thickness 0.35 mm

Zack Marker strip, flat - ZBF 5:UNBEDRUCKT - 0808642



Zack Marker strip, flat, Strip, white, Unlabeled, Can be labeled with: Plotter, Mounting type: Snap into flat marker groove, For terminal block width: 5 mm, Lettering field: 5.1 x 5.2 mm

Zack Marker strip, flat - ZBF 5/WH-100:UNBEDRUCKT - 0808668



Zack Marker strip, flat, Strip, white, Unlabeled, Can be labeled with: Plotter, Mounting type: Snap into flat marker groove, For terminal block width: 5 mm, Lettering field: 5.15 x 5.15 mm

Zack Marker strip, flat - ZBF 5,LGS:FORTL.ZAHLEN - 0808671



Zack Marker strip, flat, Strip, white, labeled, Printed horizontally: Consecutive numbers 1 - 10, 11 - 20, etc. up to 491 - 500, Mounting type: Snap into flat marker groove, For terminal block width: 5 mm, Lettering field: 5.15 x 5.15 mm

## Surge protection device - PT-IQ-1X2+F-24DC-UT - 2800977

### Accessories

Zack Marker strip, flat - ZBF 5,LGS:GERADE ZAHLEN - 0810821



Zack Marker strip, flat, Strip, white, labeled, Printed horizontally: Consecutive numbers 2 - 20, 22 - 40, etc. up to 82 - 100, Mounting type: Snap into flat marker groove, For terminal block width: 5 mm, Lettering field: 5.15 x 5.15 mm

Zack Marker strip, flat - ZBF 5,LGS:UNGERADE ZAHLEN - 0810863



Zack Marker strip, flat, Strip, white, labeled, Printed horizontally: Odd numbers 1 - 19, 21 - 39, etc. up to 81 - 99, Mounting type: Snap into flat marker groove, For terminal block width: 5 mm, Lettering field: 5.15 x 5.15 mm

Zack Marker strip, flat - ZBF 5,QR:FORTL.ZAHLEN - 0808697



Zack Marker strip, flat, Strip, white, labeled, Printed vertically: Consecutive numbers 1 - 10, 11 - 20, etc. up to 91 - 100, Mounting type: Snap into flat marker groove, For terminal block width: 5 mm, Lettering field: 5.15 x 5.15 mm

Zack marker strip - ZBN 18:UNBEDRUCKT - 2809128



Zack marker strip, Strip, white, Unlabeled, Can be labeled with: Plotter, Mounting type: Snap into tall marker groove, For terminal block width: 18 mm, Lettering field: 18 x 5 mm

Electronic housing - E/ME TBUS NS35 GY - 2713780



End clamp, stable construction for DIN rail bus connector

### Drawings

# Surge protection device - PT-IQ-1X2+F-24DC-UT - 2800977

Diagram

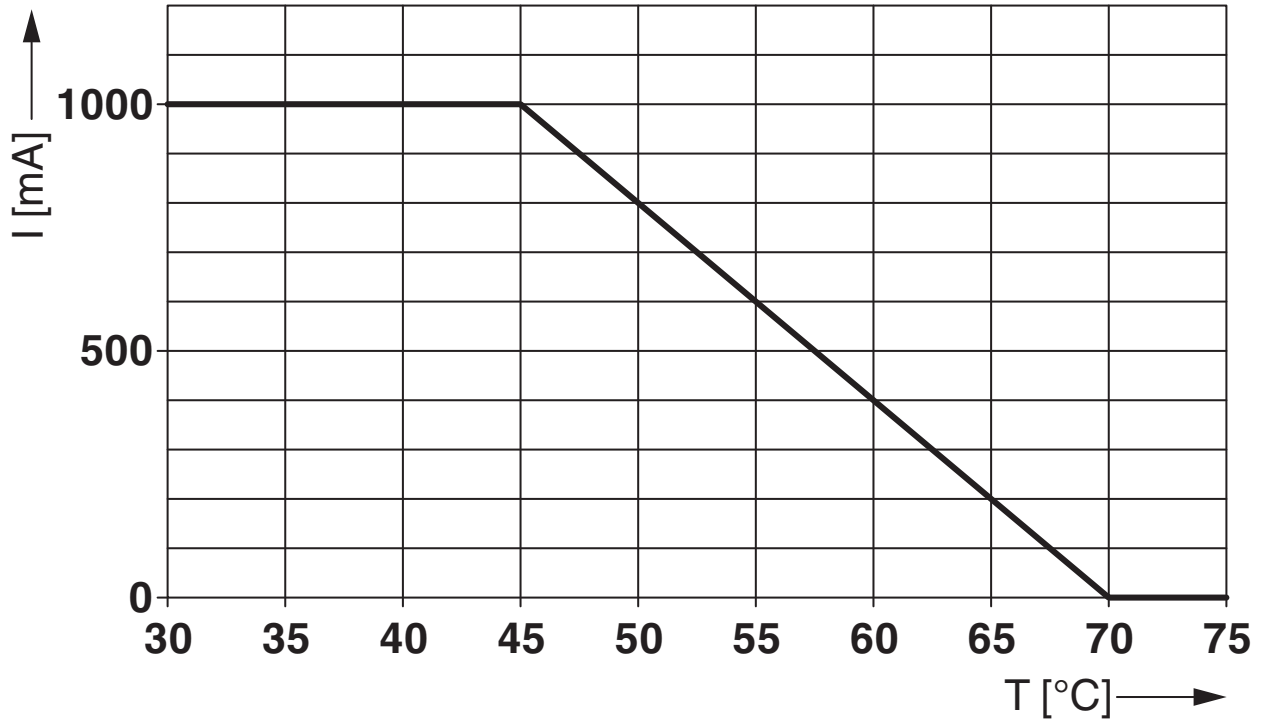

# Surge protection device - PT-IQ-1X2+F-24DC-UT - 2800977

Dimensioned drawing

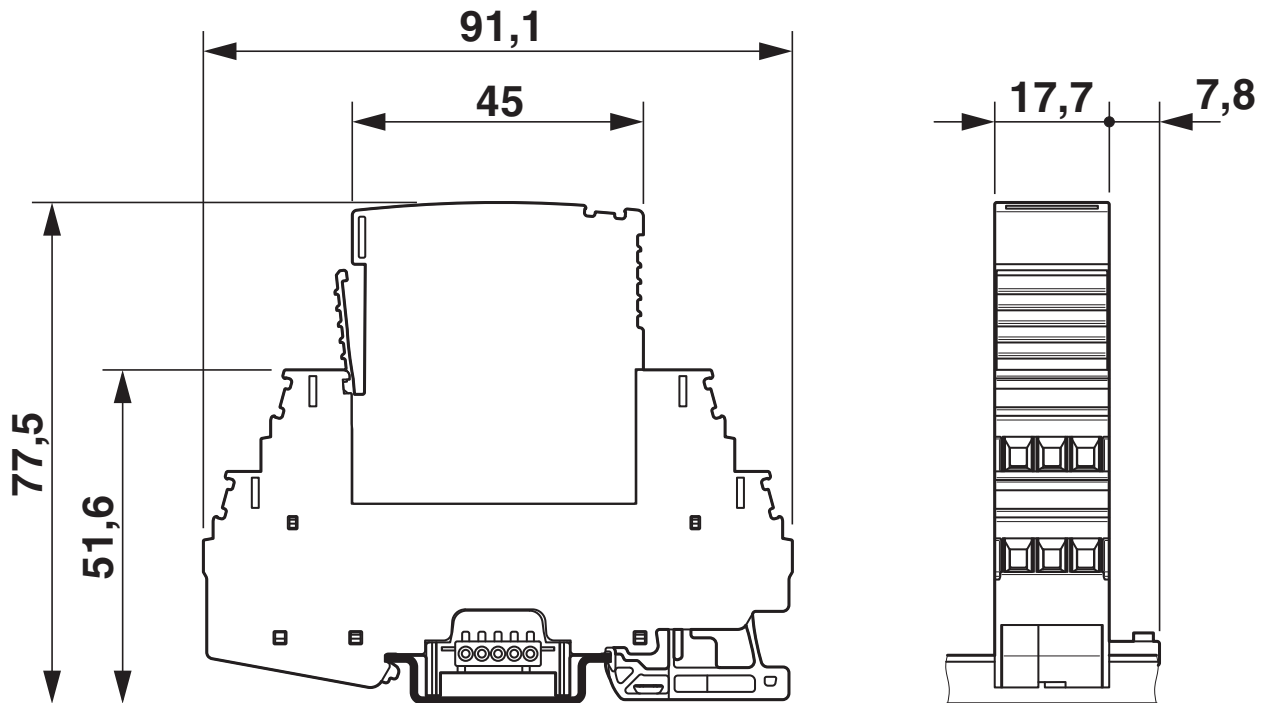

# Surge protection device - PT-IQ-1X2+F-24DC-UT - 2800977

Circuit diagram

