

Type 1/2 surge protection plug - VAL-MS-T1/T2 1000DC-PV-ST - 2801162

Please be informed that the data shown in this PDF Document is generated from our Online Catalog. Please find the complete data in the user's documentation. Our General Terms of Use for Downloads are valid (<http://phoenixcontact.com/download>)



Replacement plug for PV arrester combinations from the VAL-MS-T1/T2 1000DC-PV-... product range



Key Commercial Data

Packing unit	1 pc
GTIN	 4 046356 714310
GTIN	4046356714310

Technical data

Dimensions

Height	52.4 mm
Width	17.5 mm
Depth	55.3 mm
Horizontal pitch	1 Div.

Ambient conditions

Degree of protection	IP20
Ambient temperature (operation)	-40 °C ... 80 °C
Ambient temperature (storage/transport)	-40 °C ... 80 °C
Altitude	≤ 2000 m (amsl (above mean sea level))
Permissible humidity (operation)	5 % ... 95 %
Shock (operation)	60g (Half-sine / 11 ms / 3x ±X, ±Y, ±Z)
Vibration (operation)	7.5g (5-500 Hz/2.5 h/XYZ)

General

IEC test classification	PV I / II
	PV T1 / T2

Type 1/2 surge protection plug - VAL-MS-T1/T2 1000DC-PV-ST - 2801162

Technical data

General

EN type	T1 / T2
SPD failure behavior	OCM (Open-circuit mode)
Installation location	Inside
Accessibility	Accessible
Installation location of the disconnect device	Internal
Mounting type	on base element
Color	jet black RAL 9005
Housing material	PA 6.6-FR
Degree of pollution	2
Flammability rating according to UL 94	V-0
Type	Male
Surge protection fault message	optical

Protective circuit DC voltage side (DC)

Maximum continuous operating voltage U_{CPV}	525 V DC
Open circuit voltage U_{OCSTC}	≤ 435 V DC
Short-circuit current rating I_{SCPV}	2000 A
Continuous operating current I_{CPV}	< 20 μ A
Standby power consumption P_C	≤ 25 mVA
Nominal discharge current (8/20) μ s	15 kA
Maximum discharge current I_{max} (8/20) μ s	40 kA
Impulse discharge current (10/350) μ s, charge	2.5 As
Impulse discharge current (10/350) μ s, specific energy	6.25 kJ/ Ω
Impulse discharge current (10/350) μ s, peak value I_{imp}	5 kA
Voltage protection level U_p	≤ 1.8 kV
Residual voltage U_{res}	≤ 1.8 kV (at I_n)
	≤ 1.5 kV (at 5 kA)
	≤ 1.7 kV (at 10 kA)
	≤ 1.9 kV (at 20 kA)
	≤ 2.2 kV (at 30 kA)
	≤ 2.4 kV (at 40 kA)
Response time t_A	≤ 25 ns
Insulation resistance R_{iso}	> 5 G Ω (at 500 V DC)

Connection data

Connection method	pluggable
-------------------	-----------

UL specifications

SPD Type	1CA
Maximum continuous operating voltage MCOV	1170 V DC

Type 1/2 surge protection plug - VAL-MS-T1/T2 1000DC-PV-ST - 2801162

Technical data

UL specifications

Nominal voltage	1170 V DC
Mode of protection	(L+) - (L-)
	(L+) - G
	(L-) - G
Power distribution system	DC PV
Voltage protection rating VPR	3 kV
Nominal discharge current I_n	10 kA
Short-circuit current rating (SCCR)	50 kA

Standards and Regulations

Standards/regulations	EN 50539-11 2013
-----------------------	------------------

Drawings

Dimensional drawing

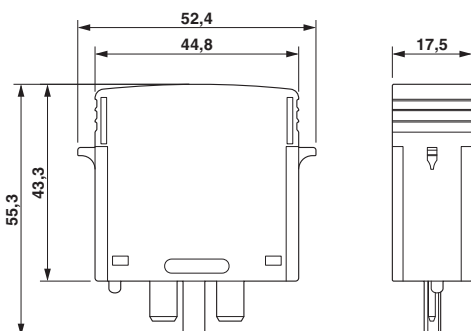

Circuit diagram



Approvals

Approvals

Approvals

UL Recognized / KEMA-KEUR / cUL Recognized / EAC / cULus Recognized

Ex Approvals

Approval details

UL Recognized		http://database.ul.com/cgi-bin/XYVV/template/LISEXT/1FRAME/index.htm	FILE E 330181
---------------	--	---	---------------

Type 1/2 surge protection plug - VAL-MS-T1/T2 1000DC-PV-ST - 2801162

Approvals

KEMA-KEUR		http://www.dekra-certification.com	71-102960
-----------	---	---	-----------

cUL Recognized		http://database.ul.com/cgi-bin/XYV/template/LISEXT/1FRAME/index.htm	FILE E 330181
----------------	---	---	---------------

EAC			RU C- DE.A*30.B01561
-----	---	--	-------------------------

cULus Recognized			
------------------	--	--	--

Phoenix Contact 2018 © - all rights reserved
<http://www.phoenixcontact.com>

PHOENIX CONTACT GmbH & Co. KG
Flachsmarktstr. 8
32825 Blomberg
Germany
Tel. +49 5235 300
Fax +49 5235 3 41200
<http://www.phoenixcontact.com>