

## ST-REL7-HG-B 24/21-21/P

Order No.: 2826156

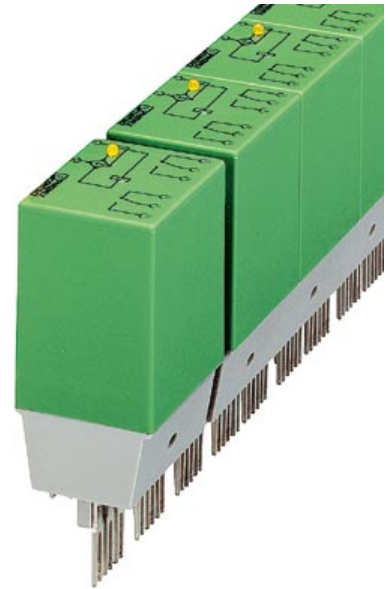

<http://eshop.phoenixcontact.de/phoenix/treeViewClick.do?UID=2826156>

Relay connector, equipped with remanence miniature switching relays, contacts (AgCdO): medium to large loads, 2 PDTs, input voltage 24 V DC, can be plugged on basic termination blocks

Commercial data	
GTIN (EAN)	4017918077846
Note	Made-to-order
sales group	G014
Pack	5 pcs.
Customs tariff	85364190
Weight/Piece	0.06263 KG
Catalog page information	Page 87 (IF-2002)

#### Product notes

WEEE/RoHS-compliant since:  
01/14/2010



<http://www.download.phoenixcontact.com>  
Please note that the data given here has been taken from the online catalog. For comprehensive information and data, please refer to the user documentation. The General Terms and Conditions of Use apply to Internet downloads.

## Technical data

### Coil side

Nominal input voltage $U_N$	24 V DC
Input voltage range in reference to $U_N$	0.8 ... 1.1
Nominal input current at $U_{IN}$	110 mA (response) 35 mA (reset/release)
Pulse time	0.1 s ... 20 s
Name of protection	Damping diode, polarity protection
Protective circuit/component	Damping diode, polarity protection diode

### Contact side

Contact type	Single contact, 2-PDT
Contact material	Silver cadmium oxide (AgCdO)
Maximum switching voltage	250 V AC 220 V DC
Maximum inrush current	4 A
Limiting continuous current	4 A
Interrupting rating (ohmic load) max.	95 W (for 24 V DC) 95 W (for 48 V DC) 65 W (for 60 V DC) 50 W (for 110 V DC) 60 W (for 220 V DC) 1000 VA (for 250 V AC)

### General data

Width	45.6 mm
Height	66.5 mm
Depth	33 mm
Test voltage relay winding/relay contact	2.5 kV AC (50 Hz, 1 min)
Test voltage PDT/PDT	2.5 kV AC (50 Hz, 1 min)
Ambient temperature (operation)	-20 °C ... 50 °C
Ambient temperature (storage/transport)	-20 °C ... 70 °C
Operating mode	100% operating factor
Service life mechanical	Approx. $10^7$ cycles
Standards/regulations	DIN VDE 0110b, Gr. C for 250 V DC DIN VDE 0160 (in relevant parts)

**Certificates / Approvals**



Certification GOST

**Additional products**

Item	Designation	Description
<b>General</b>		
2777069	UDK-RELG 7	Basic termination blocks with test connection on both sides and double connections with the same potential for NS 32 and NS 35/7,5 DIN rail, with end cover, for ST-REL..., ST-OV... and ST-OE... plugs, 7-pos.
2820178	URELG 7	Basic termination blocks with screw connection for NS 32 and NS 35/7.5 DIN rail, with end cover, for ST-REL..., ST-OV... and ST-OE... plugs, 7-pos.
2820725	URELG 7-PMTK	Basic termination blocks with test connection on both sides and knife disconnection for NS 32 and NS 35/7,5 DIN rail, with end cover, for ST-REL..., ST-OV... and ST-OE... plugs, 7-pos.
2829933	ZFK-RELG 7	Basic termination blocks with spring-cage connection for NS 35/7.5 DIN rail, with end cover, for ST-REL..., ST-OV... and ST-OE... plugs, 7-pos.

**Diagrams/Drawings**

Circuit diagram

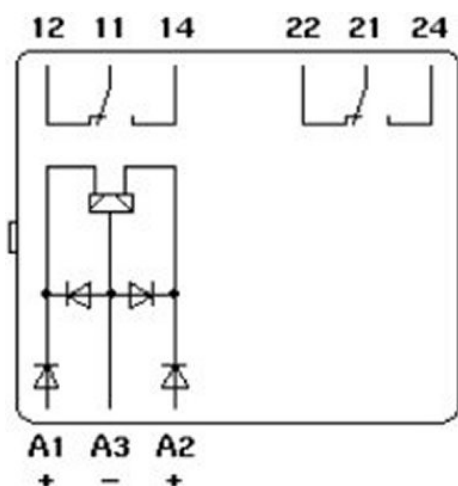

**Address**

PHOENIX CONTACT Inc., USA  
586 Fulling Mill Road  
Middletown, PA 17057, USA  
Phone (800) 888-7388  
Fax (717) 944-1625  
<http://www.phoenixcon.com>



© 2010 Phoenix Contact  
Technical modifications reserved;