

Please note that the data given here has been taken from the online catalog. For comprehensive information and data, please refer to the user documentation at <http://www.download.phoenixcontact.com>. The General Terms and Conditions of Use apply to Internet downloads.

► Extract from the online catalog



DIN rail module with device surge protection type 3 and mains suppression filter against high-frequency interference voltages. Integrated power display switches off automatically when there is a malfunction due to overload. Mounting on NS 35.

Order No.	2856702
Ord designation	SFP 1-20/120AC
EAN	4017918952648
Pack	1 Pcs.
Customs tariff	85363010
Catalog page information	Page 41 (TT-2005)

► Technical data

Product description

Device protection with interference filter

Standards

Housing material	ABS, V0(UL-94)
Inflammability class acc. to UL 94	V0
Color	Aluminum
Standards for air and creepage distances	DIN VDE 0110-1
Standards for air and creepage distances	IEC 60664-1: 1992-10
Standards for air and creepage distances	IEC 61643-1
Surge voltage category	III
Degree of contamination	2
Degree of protection	IP20
Design	Rail-mountable module, one-piece
Mounting type	DIN rail 35 mm
Ambient temperature (operation)	-40 °C ... 85 °C
For country-specific use in	USA, CN, BR
Direction of action	1L-N & N-PE

Protective circuit

IEC category	III
VDE requirement class	D
EN type	T3
Nominal voltage U_N	120 V AC
Arrester rated voltage U_c (L-PE)	200 V DC
Arrester rated voltage U_c (L-PE)	150 V AC
Nominal frequency f_N	50 Hz
Nominal frequency f_N	60 Hz
Nominal current I_N	20 A (40°C)
Operating current I_c at U_c	≤ 10 mA
Discharge current to PE at U_c	≤ 0.5 mA
TOV behavior at U_T (L-PE)	180 V (7 h)
Nominal discharge surge current I_n (8/20) μ s (L-N)	3 kA
Nominal discharge surge current I_n (8/20) μ s (L-PE)	3 kA
Max. discharge surge current I_{max} (8/20) μ s maximum (L-N)	10 kA
Max. discharge surge current I_{max} (8/20) μ s maximum (L-PE)	10 kA
Combined surge U_{oc}	6 kV (/3 kA)
Energy absorption symmetrical	170 J
Energy absorption, asymmetrical	2 x 170 J
Protection level U_p (L-N)	≤ 500 V (determined with 6 kV/3 kA)
Protection level U_p (L-PE)	≤ 500 V (determined with 6 kV/3 kA)
Protection level U_p (N-PE)	≤ 500 V
Residual voltage at I_n , (L-N)	≤ 450 V
Residual voltage at I_n , (L-PE)	≤ 450 V
Clamping voltage SVR (L-N)	≤ 400 V (at 6 kV/500 A)
Clamping voltage SVR (L-PE)	≤ 400 V (at 6 kV/500 A)
Response time t_A (L-N)	≤ 25 ns
Response time t_A (L-PE)	≤ 25 ns
Inductivity in series	2 x 1 mH ±30 % (with current compensation)
Capacity (L-N)	2 μ F ±10 % (X2, FOW X2-250V)
Capacity (L-PE)	2 x 2.2 nF ±20 % (Y, FOW X2-250V)
Required max. back-up fuse	20 A (gL / gG)
Input attenuation aE, sym.	40 dB (≥ 500 kHz / 50 Ω)
Input attenuation aE, asym.	30 dB (≥ 1 MHz / 50 Ω)
Message surge protection faulty	Remote indicator contact

Non-heating apparatus connection, power supply

Connection name	Input/output
Type of connection	Screw terminal blocks
Connection type IN	Screw terminal blocks
Connection type OUT	Screw terminal blocks
Connection system	3-conductor (shielded)
Screw thread	M 3
Tightening torque, min	0.5 Nm
Conductor cross section flexible min.	0.2 mm ²
Conductor cross section, flexible max.	4 mm ²
Conductor cross section, rigid min.	0.2 mm ²
Conductor cross section, rigid max.	6 mm ²
Conductor cross section AWG/kcmil min.	24
Conductor cross section AWG/kcmil max	10

Remote indicator contact

Connection name	Remote fault indicator contact
Switching function	Wechsler
Type of connection	Pluggable screw connection
Screw thread	M 2
Tightening torque, min	0.25 Nm
Conductor cross section flexible min.	0.14 mm ²
Conductor cross section, flexible max.	1.5 mm ²
Conductor cross section, rigid min.	0.14 mm ²
Conductor cross section, rigid max.	1.5 mm ²
Conductor cross section AWG/kcmil min.	28
Conductor cross section AWG/kcmil max	16
Maximum operating voltage U_{max} AC	250 V AC
Maximum operating voltage U_{max} DC	300 V DC
Max. operating current I_{max}	1 A
Switching capacity min. perm.	(1.00 A / 48 V DC)
Switching capacity min. perm.	(100 mA/ 12 V AC)
Switching capacity max. perm.	(0.25 A / 250 V DC)
Switching capacity max. perm.	(1.0 A / 48 V AC)

Connection, protective circuit

Standards/regulations	IEC 61643
Standards/regulations	EN 61643-11
Standards/regulations	UL 1449
Standards/regulations	UL 1283

Protective circuit, filter

Discharge resistor	
Clamping voltage ringwave (L-N)	100 V (category A 100 kHz 6 kV/200 A)
Clamping voltage ringwave (L-N)	195 V (category B 100 kHz 6 kV/500 A)
Clamping voltage ringwave (L-PE)	390 V (category A 100 kHz 6 kV/200 A)
Clamping voltage ringwave (L-PE)	390 V (category B 100 kHz 6 kV/500 A)

► Certificates

Certificate logos



CUL

Nominal voltage U_N	120 V
Nominal current I_N	20 A
AWG/kcmil	12-10

UL

Nominal voltage U_N	120 V
Nominal current I_N	20 A
AWG/kcmil	12-10

▸ Drawings

Circuit diagram

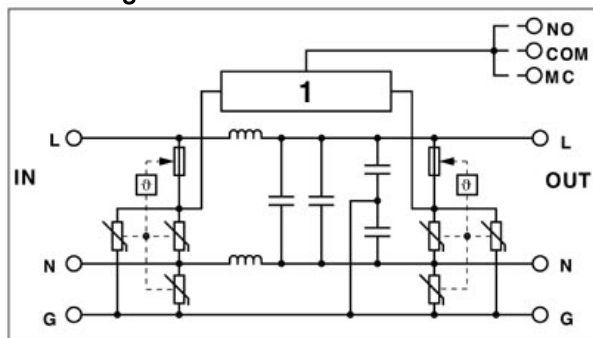



► Address

PHOENIX CONTACT Inc., USA
586 Fulling Mill Road
Middletown, PA 17057
USA
Phone (800) 888-7388
Fax (717) 944-1625
<http://www.phoenixcon.com>
Phoenix Contact
Technical modifications reserved;